

L'TR	REVISION	DATE	BY	E.C.O.
*	ORIGINAL ISSUE	04/20/20	CJR	1998

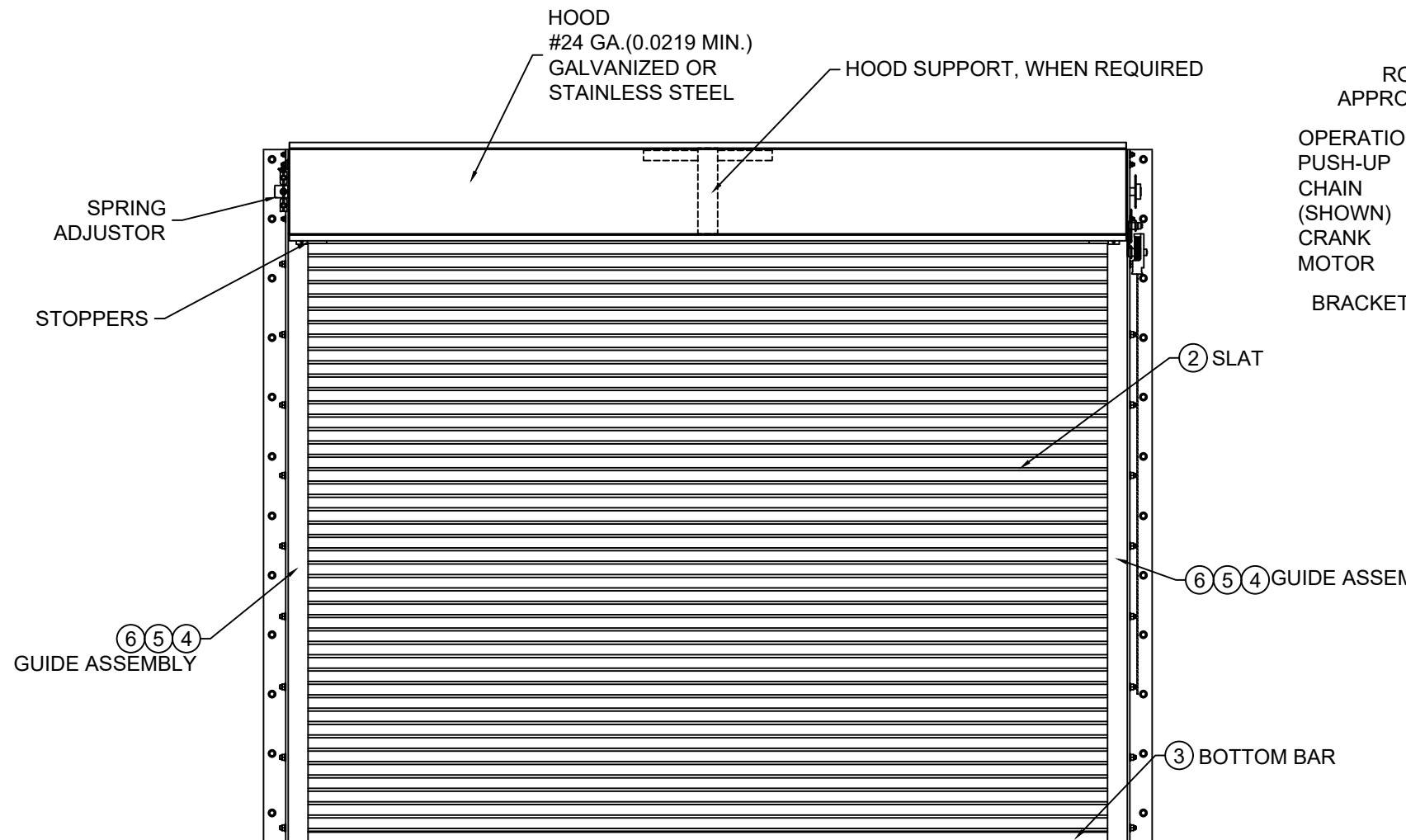

ROLL-UP MECHANISM NOT INCLUDED IN THIS APPROVAL. MUST BE CERTIFIED BY AN INDEPENDENT TESTING AGENCY IF REQUIRED.

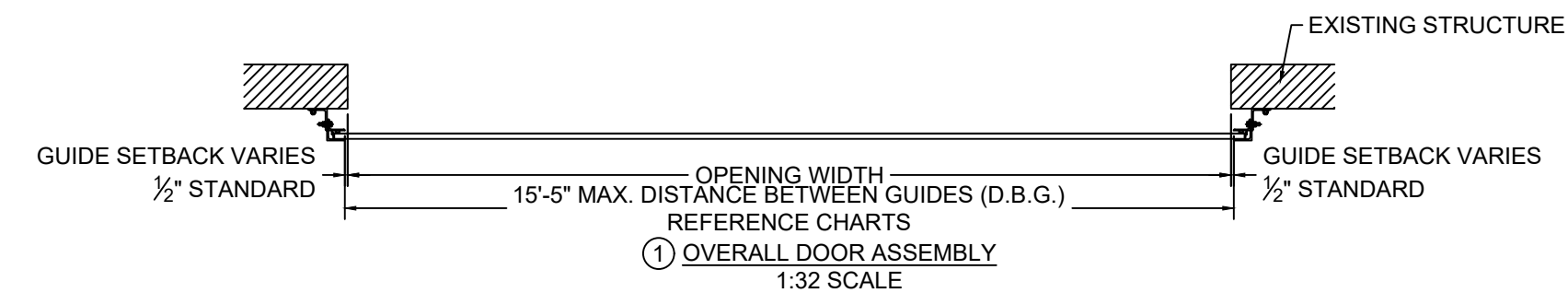
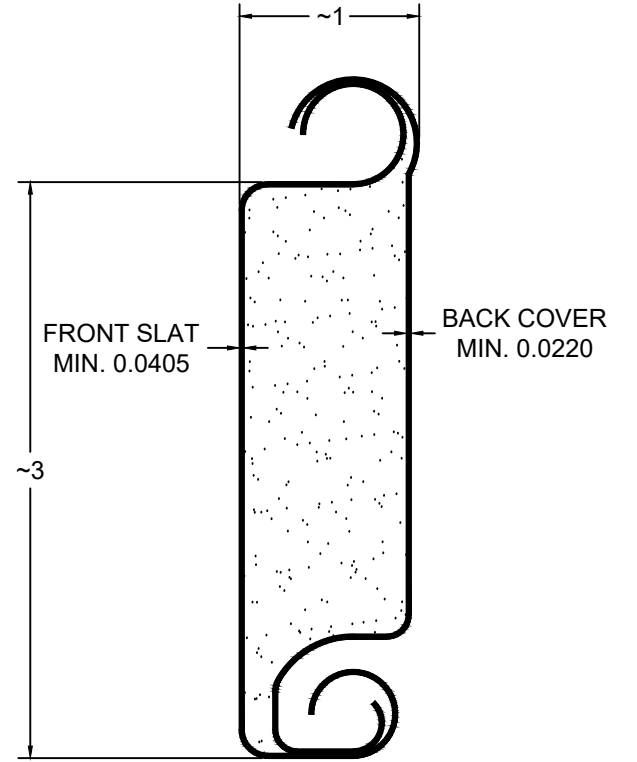
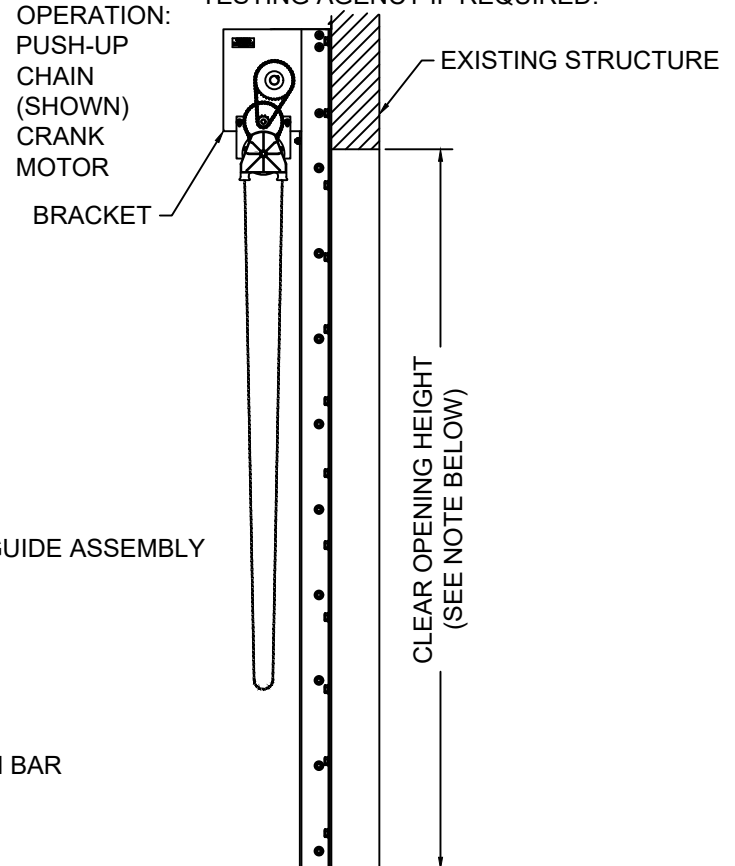

NOTE: WIND LOADS SPECIFIED IN TABLES ARE ACCEPTABLE FOR ANY C.O.H. UP TO 30'-0"

**② SLAT DETAIL**  
TYPICAL SECTION  
ASTM A653 HSLAS TYPE B GRADE 40 G40 OR  
ASTM A653 HSLAS TYPE A GRADE 40 G40 OR  
ASTM A653 STRUCTURAL STEEL GRADE 40 G40  
OR TYPE 304 STAINLESS STEEL (MIN. YIELD 40,000 psi)  
OR TYPE 316 STAINLESS STEEL (MIN. YIELD 40,000 psi)  
OR TYPE 430 STAINLESS STEEL (MIN. YIELD 40,000 psi)  
OR TYPE 201 STAINLESS STEEL (MIN. YIELD 40,000 psi)  
FULL SCALE



	24 ELMWOOD AVE 1901 S. LITCHFIELD RD MOUNTAINTOP, PA GOODYEAR, AZ		Unless otherwise specified, dimensions are in inches & tolerances are:  0.000 = +/- 0.031 FRACTIONAL = +/- 1/32 ANGLES = +/- 1/2 DEG		
	P: 800.390.8590 F: 866.448.6798 E: ADS@COOKSONDOOR.COM		DRAWN BY: <b>CJR</b>	SIZE: <b>B</b>	SCALE: <b>AS NOTED</b>
TITLE: <b>WIND LOAD CONFIGURATION HIGH PERFORMANCE INSULATED ROLLING STEEL DOOR CP0001/CP0651 SLAT IMPACT RATED</b>			DWG NO: <b>ES 16-101-TCCI</b>		

L'TR	REVISION	DATE	BY	E.C.O.
*	ORIGINAL ISSUE	04/20/20	CJR	1998

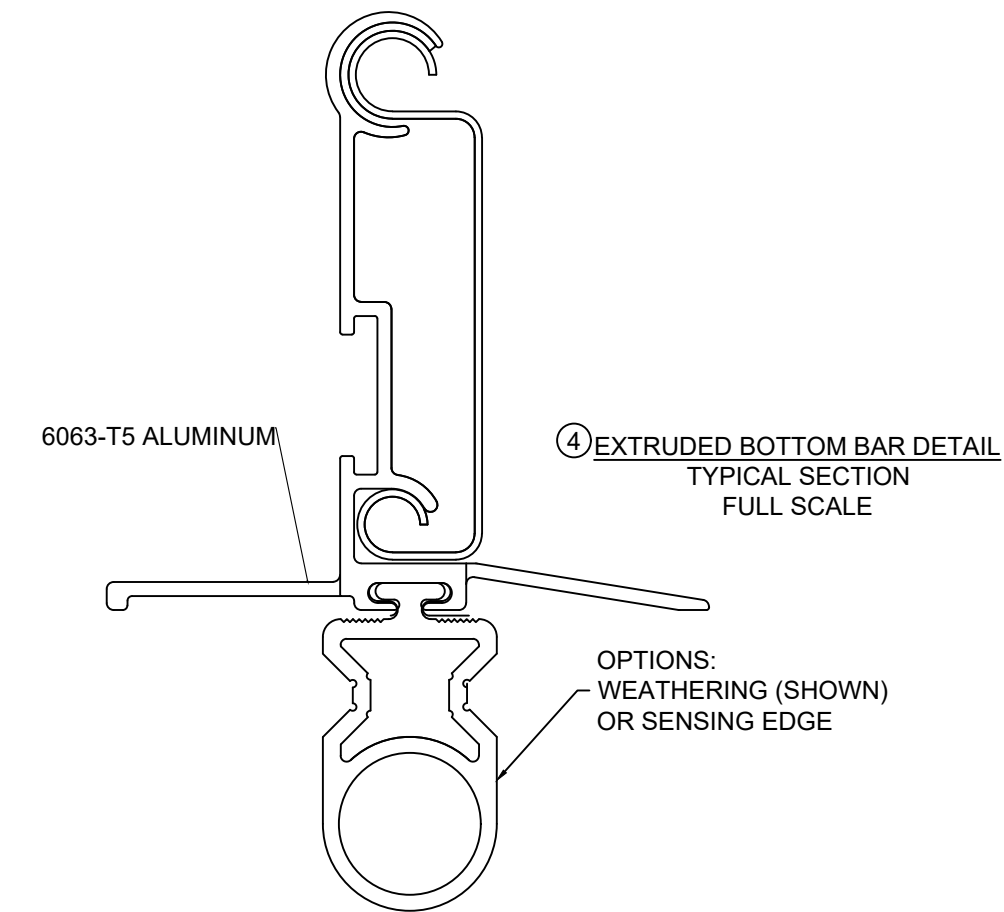
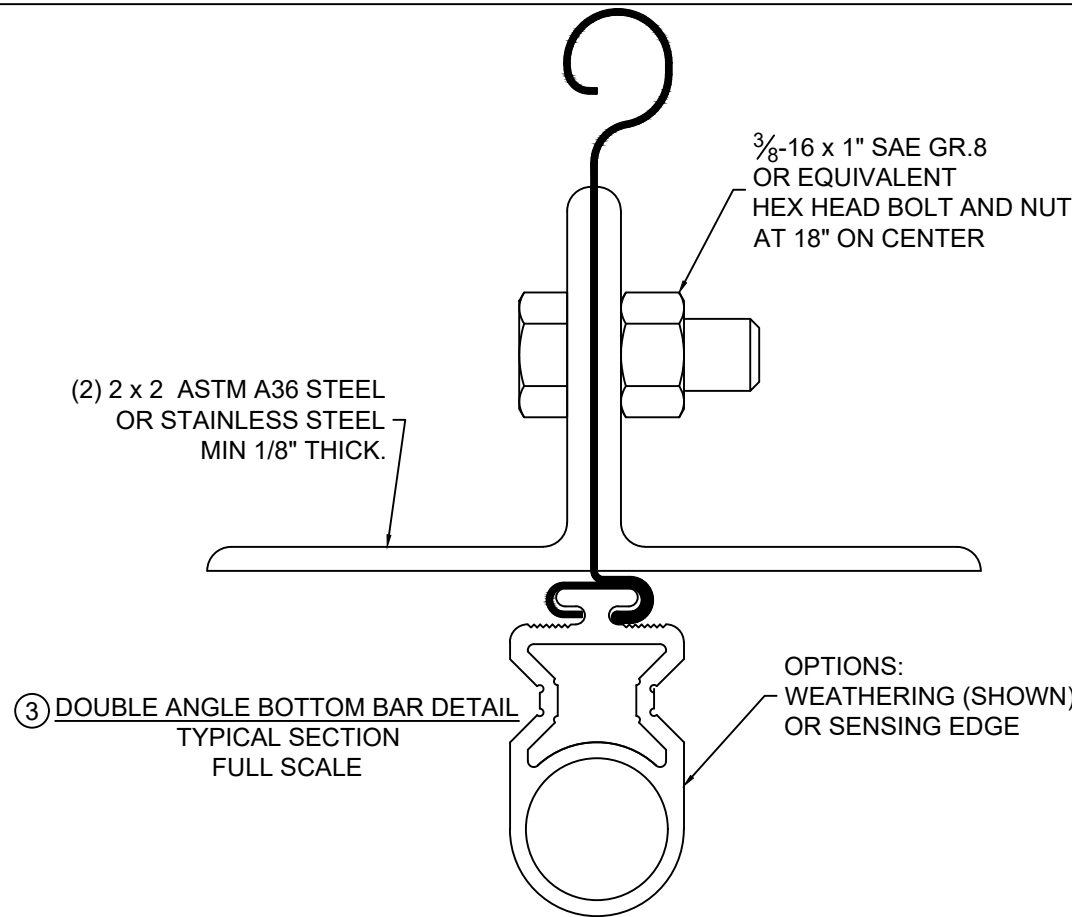

**GENERAL NOTES:**

1. THESE PRODUCT EVALUATION DOCUMENTS REPRESENT A ROLL-UP DOOR ASSEMBLY DESIGNED AND TESTED IN ACCORDANCE WITH THE 2018 INTERNATIONAL BUILDING CODE AND THE FLORIDA BUILDING CODE.
2. THIS ROLL-UP DOOR HAS BEEN TESTED FOR UNIFORM STATIC PRESSURE, IMPACT AND FATIGUE RESISTANCE IN ACCORDANCE WITH THE FBC TEST PROTOCOLS FOR HIGH VELOCITY HURRICANE ZONES TAS 201, TAS 202, AND TAS 203.
3. A 33% INCREASE IN ALLOWABLE STRESS HAS NOT BEEN USED IN THE DESIGN OF THIS PRODUCT.
4. DETERMINE THE POSITIVE AND NEGATIVE DESIGN LOADS TO USE WHEN REFERENCING THESE DOCUMENTS IN ACCORDANCE WITH THE GOVERNING CODE AND GOVERNING WIND VELOCITY.
5. THESE PRODUCT EVALUATION DOCUMENTS ARE PREPARED BY THE PRODUCT ENGINEER AND ARE GENERIC. THEY DO NOT INCLUDE INFORMATION PREPARED FOR A SPECIFIC SITE.
6. THESE PRODUCT EVALUATION DOCUMENTS ARE NOT VALID FOR PERMIT WITHOUT ORIGINAL SIGNATURE, DATE AND EMBOSSED SEAL ON EACH PERMIT COPY, WHETHER OR NOT A MASTER APPROVAL DOCUMENT IS ON FILE WITH A MUNICIPALITY OR OTHER GOVERNING AGENCY.
7. THESE PRODUCT EVALUATION DOCUMENTS ARE SUITABLE TO BE APPLIED BY THE CONTRACTOR PROVIDED THE CONTRACTOR DOES NOT DEVIATE FROM THE CONDITIONS DETAILED HEREIN AND THE CONTRACTOR VERIFIES THE EXISTING STRUCTURE IS CAPABLE OF SUPPORTING THE SUPERIMPOSED LOADS  $V_x$  &  $V_y$  ON THE JAMBS OF THE DOOR.
8. ALTERATIONS OR ADDITIONS TO THIS DOCUMENT ARE NOT PERMITTED.
9. WHEN THE SITE CONDITIONS DEVIATE FROM THESE PRODUCT EVALUATION DOCUMENTS, SITE SPECIFIC DOCUMENTS SHALL BE PREPARED BY A DULY LICENSED AND REGISTERED ENGINEER OR ARCHITECT.
10. IF THE DEVIATING SITE SPECIFIC DOCUMENTS ARE PREPARED BY A DELEGATED REGISTERED ENGINEER OR ARCHITECT, SAID DOCUMENTS SHALL BEAR THE DATE, SIGNATURE, AND EMBOSSED SEAL OF THE DELEGATED ENGINEER OR ARCHITECT AND SHALL BE SUBMITTED TO THE PROJECT ENGINEER FOR REVIEW.
11. ALL HARDWARE SHALL BE GALVANIZED STEEL, PLATED STEEL OR STAINLESS STEEL
12. ALL WINDLOCK RIVETS SHALL BE 1/4" STEEL RIVETS IFI GRADE 30 WITH A MINIMUM TENSILE STRENGTH OF 1,850 Lbs., AND SHEAR STRENGTH OF 2,400 Lbs., U.O.N.. RIVETS TO BE INSTALLED IN ALL WINDLOCK HOLES.
13. ENDLOCKS/WINDLOCKS SHALL BE STAMPED STEEL AND MUST CONFORM TO ASTM A36 OR EQUIVALENT.
14. ALL WELDING SHALL BE PERFORMED BY QUALIFIED WELDERS IN ACCORDANCE WITH A.W.S. SPECIFICATIONS, LATEST EDITION. ALL WELDING ELECTRODES SHALL CONFORM TO A.W.S. A5.1 GRADE E-70. MINIMUM WELDING PROCESSES SHALL BE ARC WELDING A.W.S. E7014 OR MIG WELDING A.W.S. ER70S-6.
15. ANCHOR NOTES:  
 A. EMBEDMENT LENGTH DOES NOT INCLUDE STUCCO FINISH.  
 B. ANCHORS SHALL BE INSTALLED IN ACCORDANCE WITH MANUFACTURERS SPECIFICATIONS.  
 C. ANCHOR CAPACITY FOR THIS ROLL-UP DOOR IS BASED ON MIN. 3,000 P.S.I. CONCRETE EXCEPT WHERE NOTED..  
 D. FOR MINIMUM EMBEDMENT AND MINIMUM EDGE DISTANCE, REFER TO TABLES.
16. DOOR MAY BE INSTALLED ON THE INSIDE OR OUTSIDE OF AN EXTERIOR WALL
17. ALL SHAPES USED FOR GUIDE ASSEMBLIES MUST CONFORM TO ATSM A36 FOR STEEL OR ASTM A276 FOR TYPES 304 OR 316 WITH A MINIMUM 36 KSI YIELD STRENGTH.



	24 ELMWOOD AVE 1901 S. LITCHFIELD RD MOUNTAINTOP, PA GOODYEAR, AZ	Unless otherwise specified, dimensions are in inches & tolerances are:  0.000 = +/- 0.031 FRACTIONAL = +/- 1/32 ANGLES = +/- 1/2 DEG
	P: 800.390.8590 F: 866.448.6798 E: ADS@COOKSONDOOR.COM	
TITLE: WIND LOAD CONFIGURATION HIGH PERFORMANCE INSULATED ROLLING STEEL DOOR CP0001/CP0651 SLAT IMPACT RATED	DRAWN BY: CJR DWG NO: ES 16-101-TCCI	SIZE: B SCALE: AS NOTED SHEET: 2/8

L'TR	REVISION	DATE	BY	E.C.O.
*	ORIGINAL ISSUE	04/20/20	CJR	1996

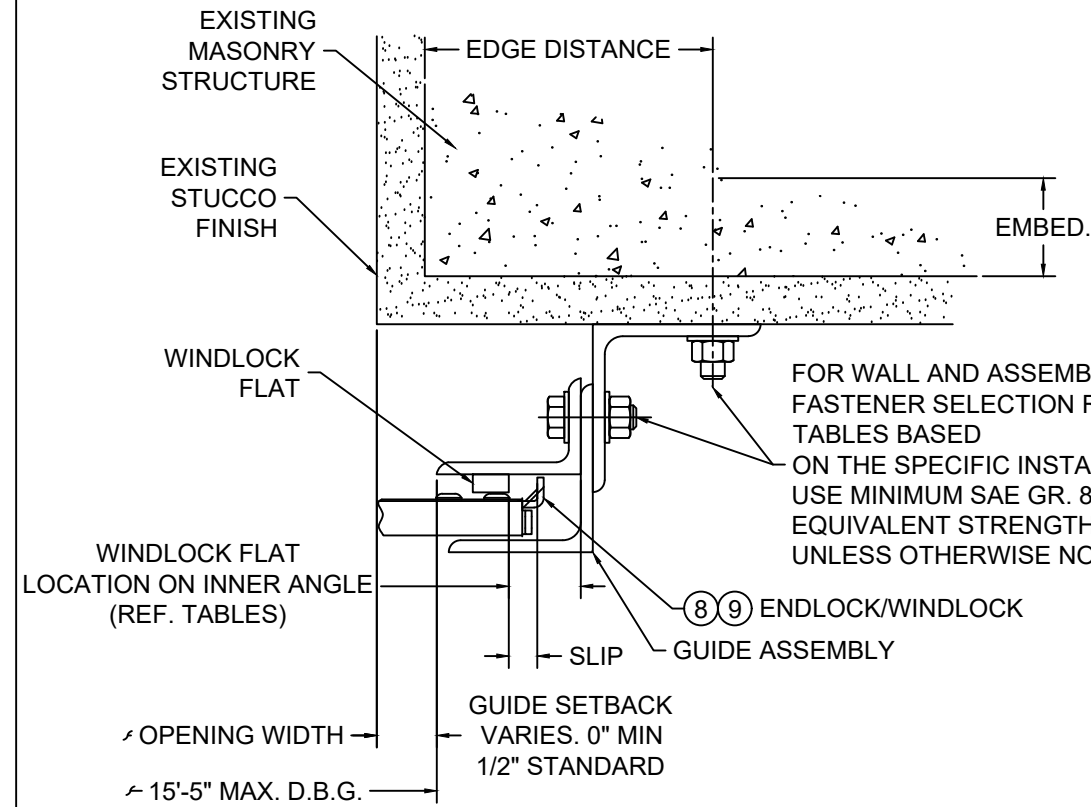

NOTE:  
THROUGH BOLTING TO FILLED BLOCK REQUIRES THE USE OF 1/4"  
THICK STEEL OR STAINLESS STEEL CRUSH PLATE

⑤ GUIDE ASSEMBLY  
CONCRETE OR FILLED BLOCK  
STRUCTURE  
(Z-GUIDE)

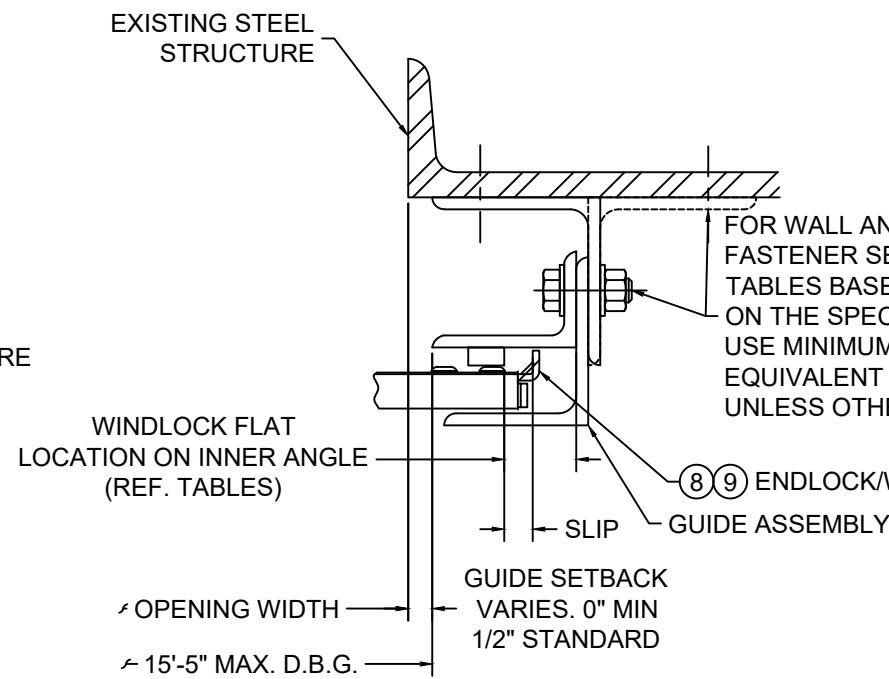

⑥ GUIDE ASSEMBLY  
STEEL STRUCTURE  
(Z-GUIDE OR E-GUIDE)

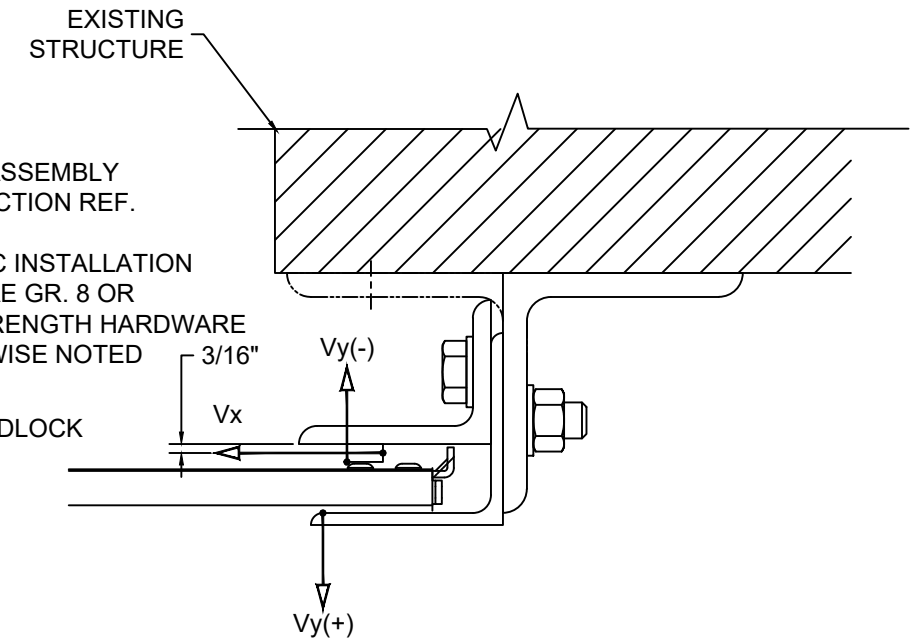

NOTE:

1.  $V_x$  &  $V_y$  ARE HORIZ. AND VERT. COMPONENTS OF THE REACTION, RESPECTIVELY, RESULTING FROM WIND LOADS ON THE ROLL-UP DOOR. THE EXISTING STRUCTURE SHALL BE CAPABLE OF RESISTING  $V_x$  &  $V_y$  FORCES SHOWN AND THE CORRESPONDING REACTIONS DUE TO THE ECCENTRICITIES OF THE FORCES.

⑦ SUPERIMPOSED LOAD DIAGRAM  
SCALE: 3" = 1'-0"

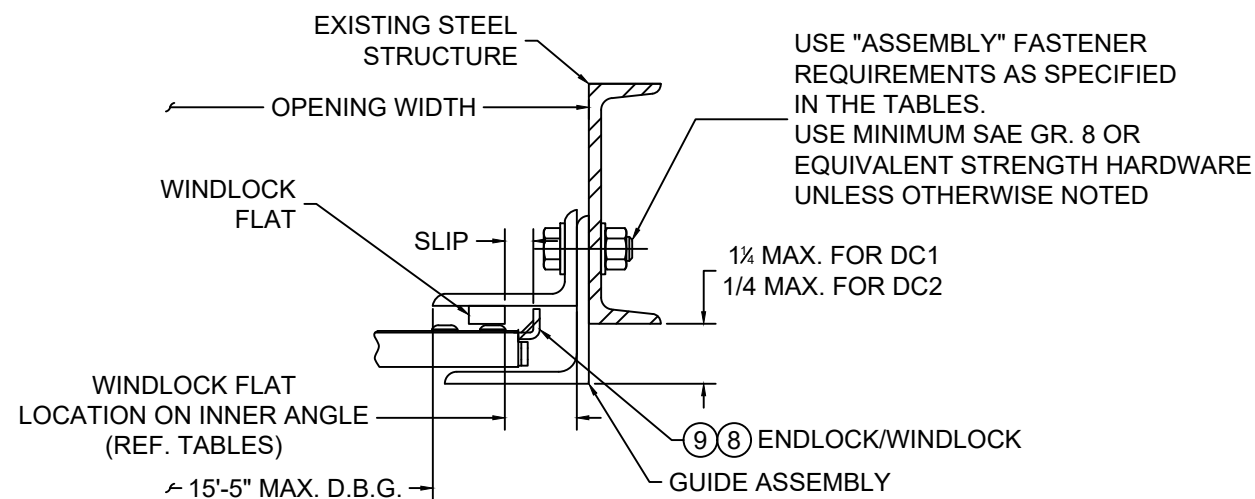

④ GUIDE ASSEMBLY  
STEEL STRUCTURE  
(BETWEEN JAMBS GUIDE)

USE "ASSEMBLY" FASTENER REQUIREMENTS AS SPECIFIED IN THE TABLES.  
USE MINIMUM SAE GR. 8 OR EQUIVALENT STRENGTH HARDWARE UNLESS OTHERWISE NOTED



24 ELMWOOD AVE 1901 S. LITCHFIELD RD  
MOUNTAINTOP, PA GOODYEAR, AZ  
P: 800.390.8590  
F: 866.448.6798  
E: ADS@COOKSONDOOR.COM

Unless otherwise specified, dimensions are in inches & tolerances are:

0.000 = +/- 0.031  
FRACTIONAL = +/- 1/32  
ANGLES = +/- 1/2 DEG

TITLE: WIND LOAD CONFIGURATION HIGH PERFORMANCE INSULATED ROLLING STEEL DOOR CP0001/CP0651 SLAT IMPACT RATED	DRAWN BY: <b>CJR</b>	SIZE: <b>B</b>	SCALE: <b>AS NOTED</b>	SHEET: <b>3/8</b>
	DWG NO: <b>ES 16-101-TCCI</b>			

L'TR	REVISION	DATE	BY	E.C.O.
*	ORIGINAL ISSUE	04/20/20	CJR	1996

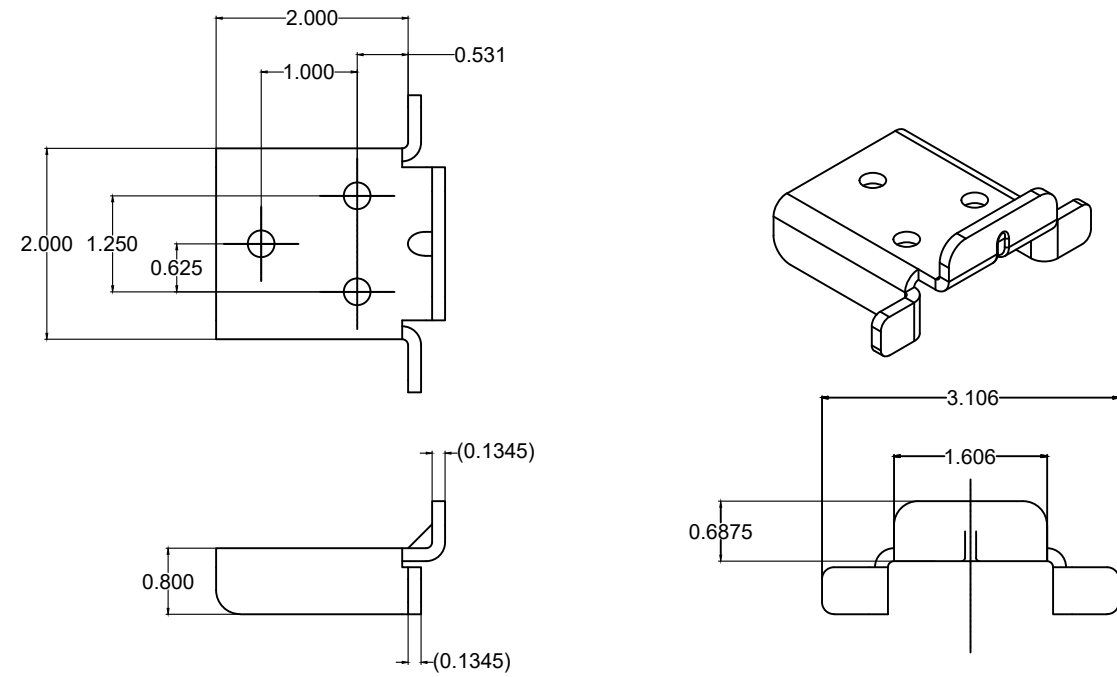

⑧ **ENDLOCK / WINDLOCK DETAIL, CP1413**  
 STAMPED STEEL IN ACCORDANCE WITH ASTM A36 OR EQUIVALENT,  
 GALVANIZED IN ACCORDANCE WITH ASTM A123, GRADE 85 ZINC-COATING  
 1/2 SCALE

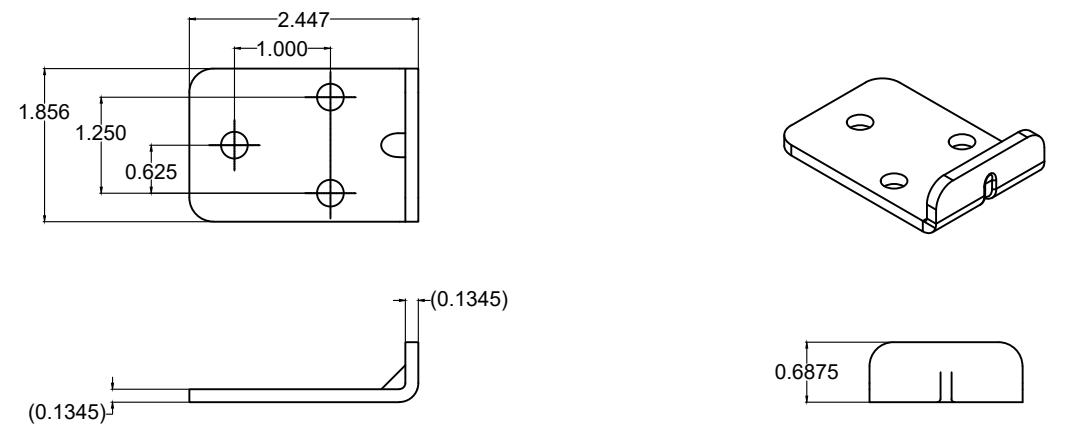

⑨ **WINDLOCK DETAIL, CP1514**  
 STAMPED STEEL IN ACCORDANCE WITH ASTM A36 OR  
 EQUIVALENT, GALVANIZED IN ACCORDANCE WITH ASTM A123,  
 GRADE 85 ZINC-COATING  
 1/2 SCALE

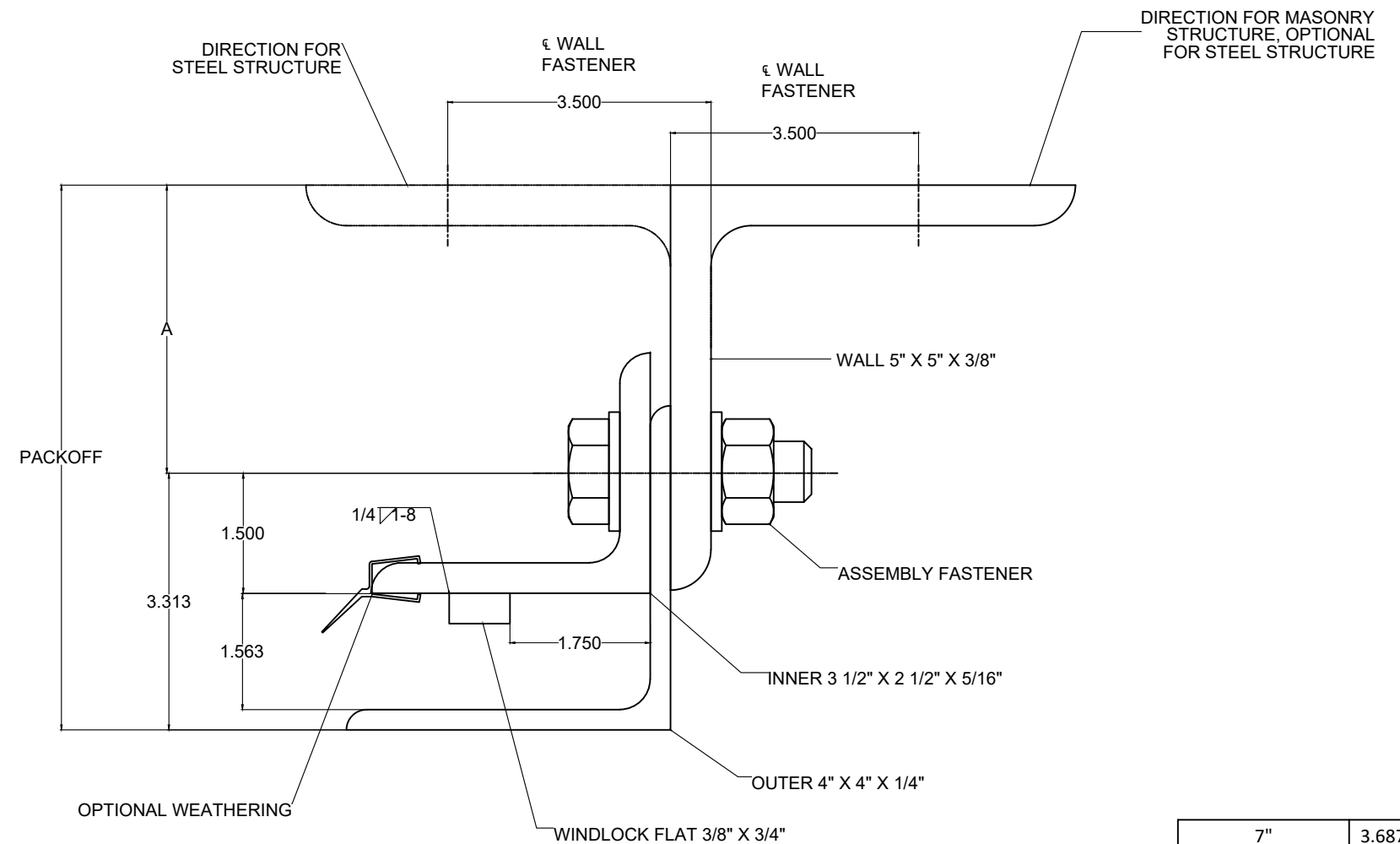

GUIDE ASSEMBLY TYPE 546  
 SCALE: NTS

7"	3.6875"
6 3/4"	3.4375"
6 1/2"	3.1875"
6 1/4"	2.9375"
6"	2.6875"
5 3/4"	2.4375"
5 1/2"	2.1875"
5 1/4"	1.9375"
PACKOFF	A



**COOKSON**  
 Preferred door solutions.™

24 ELMWOOD AVE 1901 S. LITCHFIELD RD  
 MOUNTAINTOP, PA GOODYEAR, AZ  
 P: 800.390.8590  
 F: 866.448.6798  
 E: ADS@COOKSONDOOR.COM

Unless otherwise specified,  
 dimensions are in inches &  
 tolerances are:

0.000 = +/- 0.031  
 FRACTIONAL = +/- 1/32  
 ANGLES = +/- 1/2 DEG

TITLE: WIND LOAD CONFIGURATION HIGH PERFORMANCE INSULATED ROLLING STEEL DOOR CP0001/CP0651 SLAT IMPACT RATED	DRAWN BY: <b>CJR</b>	SIZE: <b>B</b>	SCALE: <b>AS NOTED</b>	SHEET: <b>4/8</b>
	DWG NO: <b>ES 16-101-TCCI</b>			

L'TR	REVISION	DATE	BY	E.C.O.
*	ORIGINAL ISSUE	04/20/20	CJR	1996

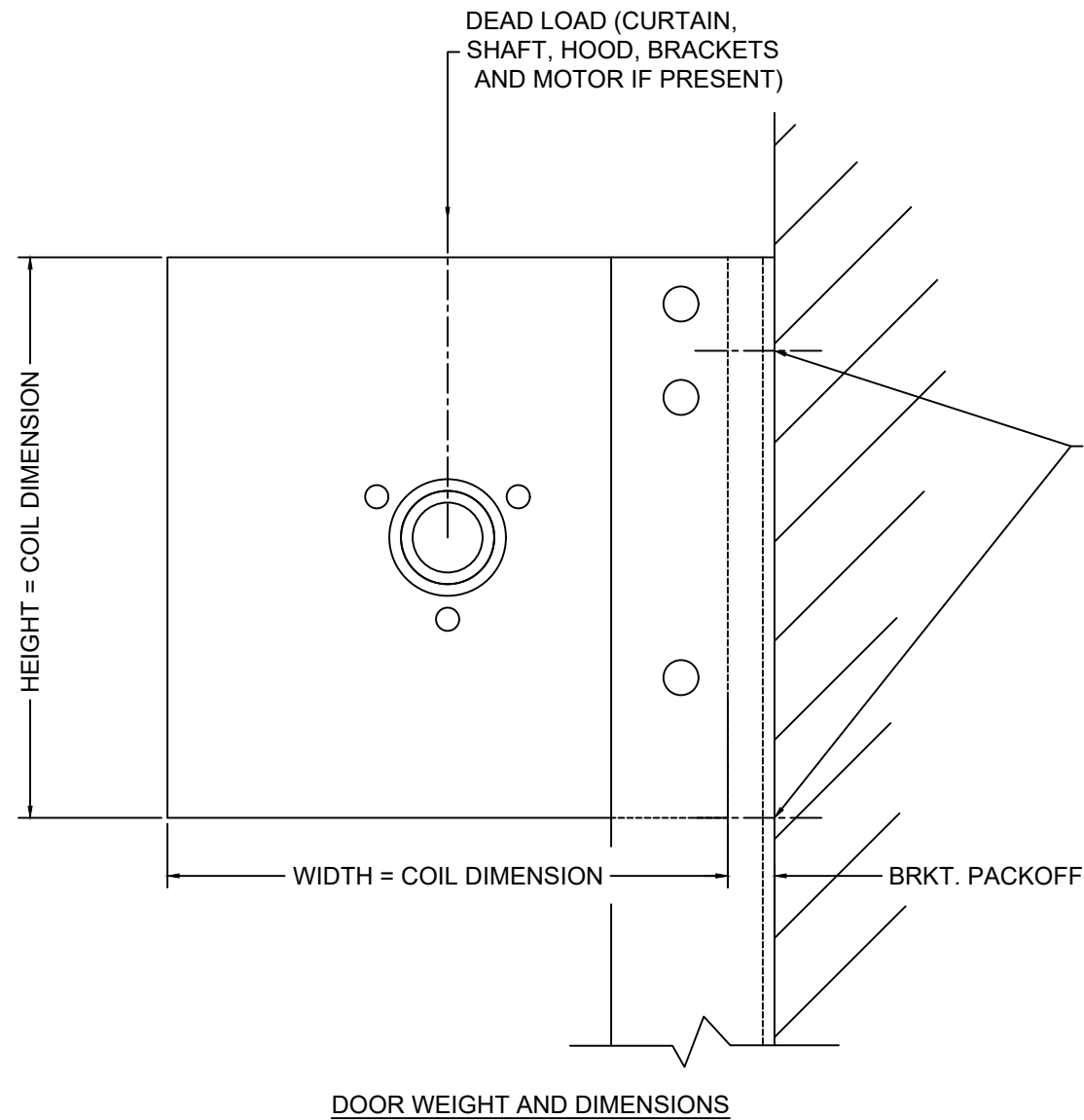

FOR "WALL ANGLE" TO WALL CONNECTION, REF. TABLES BASED ON THE SPECIFIC INSTALLATION. USE AT LEAST ONE FASTENER OR WELD AT THE INDICATED LOCATIONS.

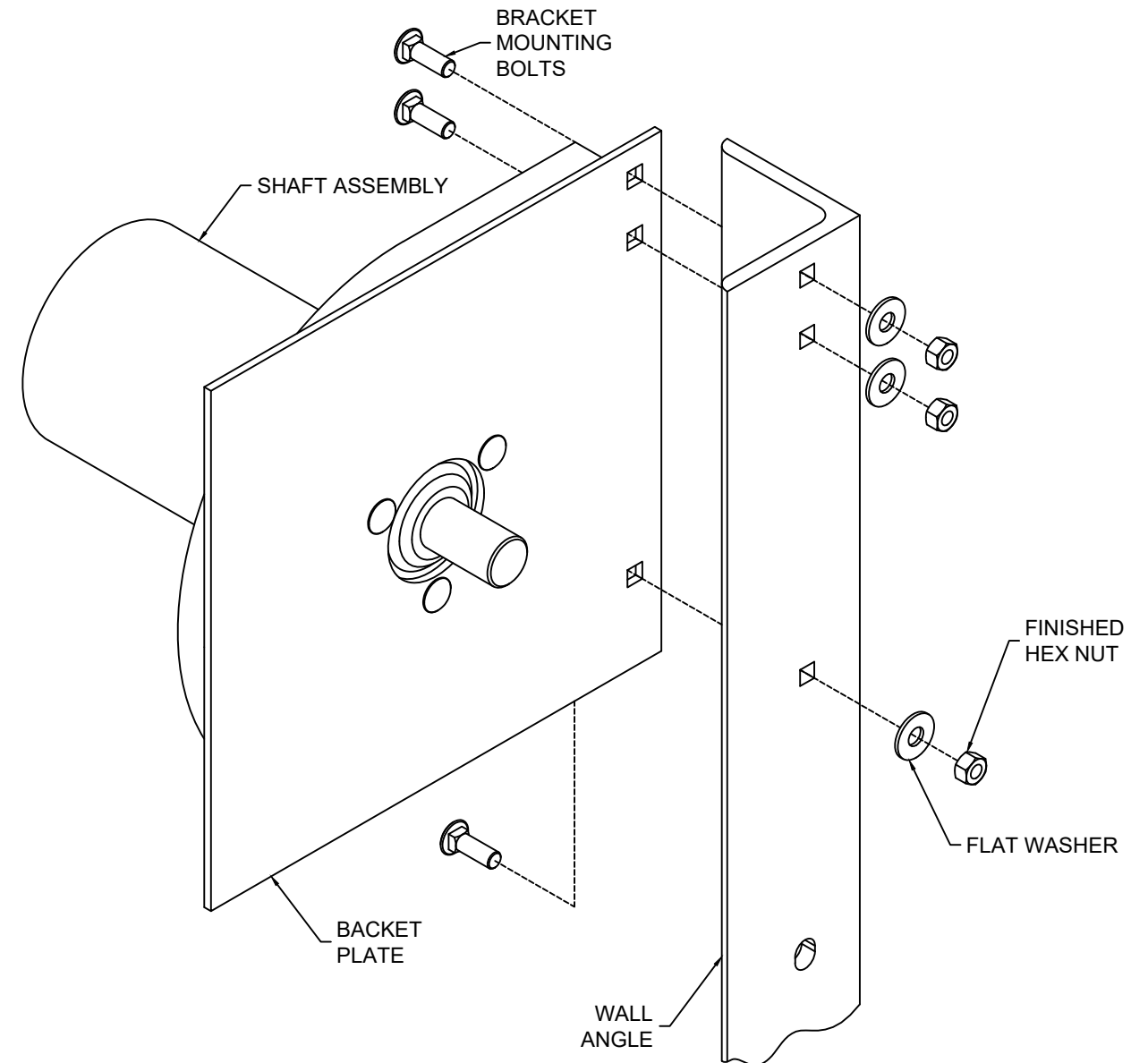

NOTE:

BRACKET MOUNTING

1. STANDARD BRACKET MOUNTING DETAIL IS DEPICTED, OTHER MOUNTINGS ARE AVAILABLE

NOTE:

1. WHEN MOTOR IS PROVIDED, HEIGHT OR WIDTH DIMENSION MAY INCREASE UP TO 2-1/2" BASED ON MOTOR LOCATION. WHEN AN 8" DIAMETER OR LARGER SHAFT ASSEMBLY IS PROVIDED, HEIGHT DIMENSION INCREASES BY 2".
2. WHEN COIL BOX STRUCTURE IS PROVIDED HEIGHT AND WIDTH DIMENSION WILL INCREASE BY 4"



**COOKSON**  
Preferred door solutions.

24 ELMWOOD AVE 1901 S. LITCHFIELD RD  
MOUNTAINTOP, PA GOODYEAR, AZ  
P: 800.390.8590  
F: 866.448.6798  
E: ADS@COOKSONDOOR.COM

Unless otherwise specified, dimensions are in inches & tolerances are:  
0.000 = +/- 0.031  
FRACTIONAL = +/- 1/32  
ANGLES = +/- 1/2 DEG

TITLE: WIND LOAD CONFIGURATION  
HIGH PERFORMANCE  
INSULATED ROLLING STEEL DOOR  
CP0001/CP0651 SLAT IMPACT RATED

DRAWN BY: CJR  
SIZE: B  
SCALE: AS NOTED  
SHEET: 5/8

DWG NO: ES 16-101-TCCI

L'TR	REVISION	DATE	BY	E.C.O.
*	ORIGINAL ISSUE	04/20/20	CJR	1996

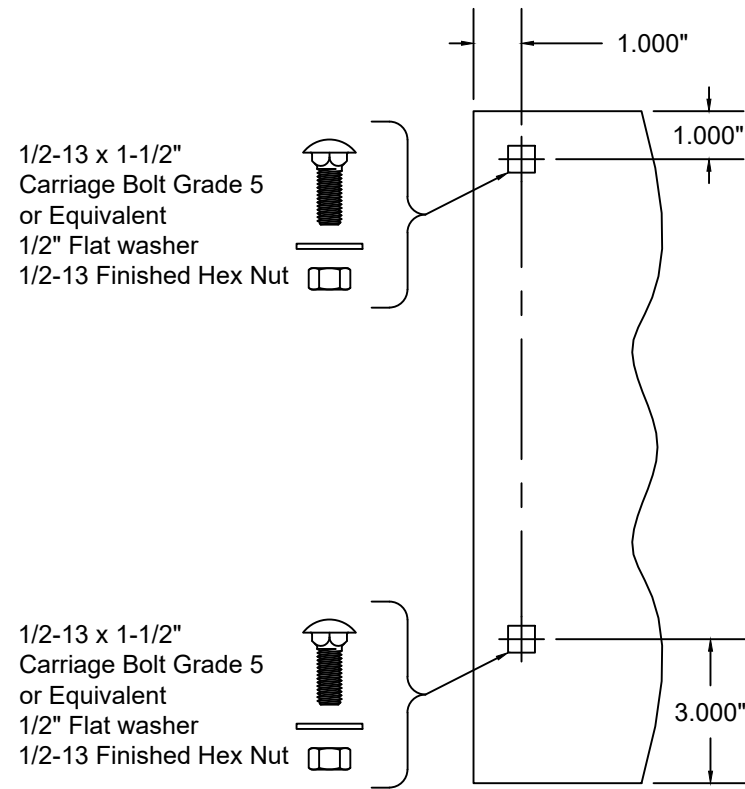

**THRU 6"Ø SHAFT ASSEMBLY**  
 14" THRU 16" COIL DIMENSION  
 MIN. THICKNESS 0.172" ASTM A36 STEEL  
 OR ASTM A480 STAINLESS STEEL,  
 TYPES 304 OR 316, MIN. 36 KSI YIELD STRENGTH  
 SCALE: 1-1/2" = 1'-0"

**NOTE:**  
 1. WHEN A 8"Ø OR LARGER SHAFT ASSEMBLY IS PROVIDED,  
 THERE IS A 2" EXTENSION ON THE BOTTOM OF THE BRACKET.  
 2. A 1/2-13 x 1-1/2" GRADE 8 HEX BOLT WILL BE SUBSTITUTED  
 FOR THE CARRIAGE BOLTS WHEN COIL BOX STRUCTURE IS  
 REQUIRED.

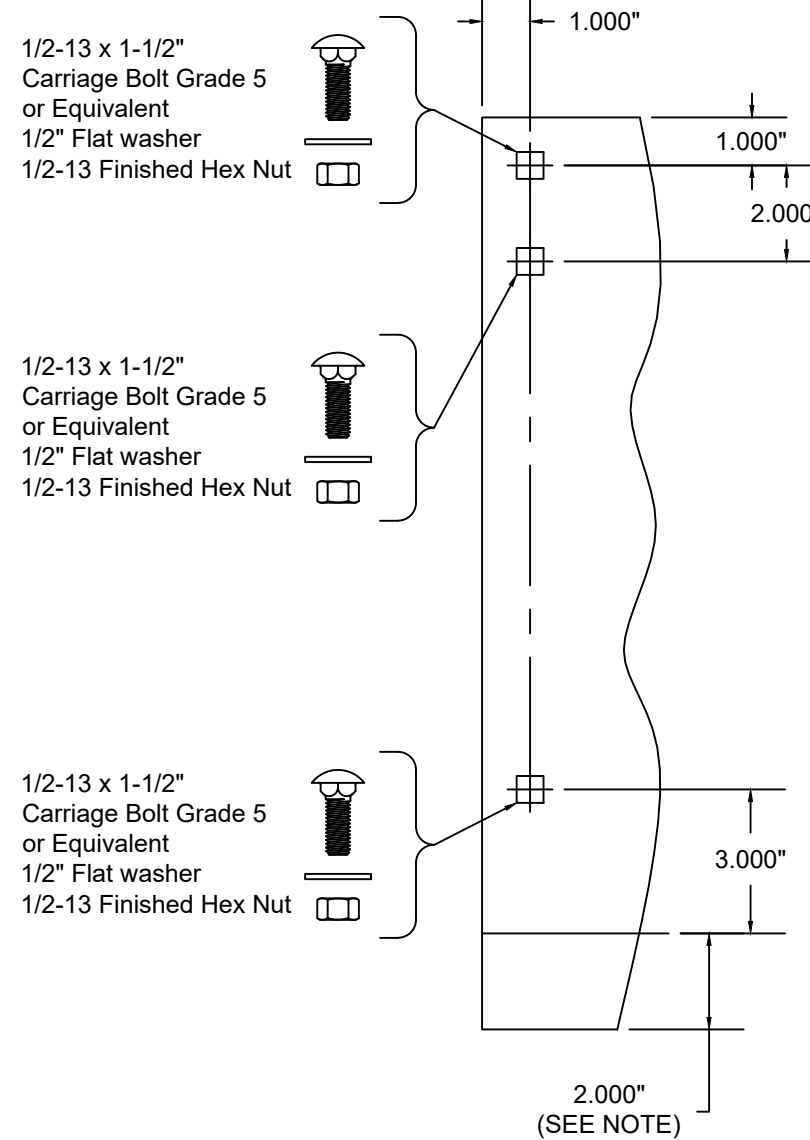

**THRU 10"Ø SHAFT ASSEMBLY**  
 ALL UNITS REQUIRING A COIL BOX STRUCTURE OR  
 17" AND LARGER COIL DIMENSION  
 MIN. THICKNESS 0.240" ASTM A36 STEEL  
 OR ASTM A480 STAINLESS STEEL,  
 TYPES 304 OR 316, MIN. 36 KSI YIELD STRENGTH  
 SCALE: 1-1/2" = 1'-0"

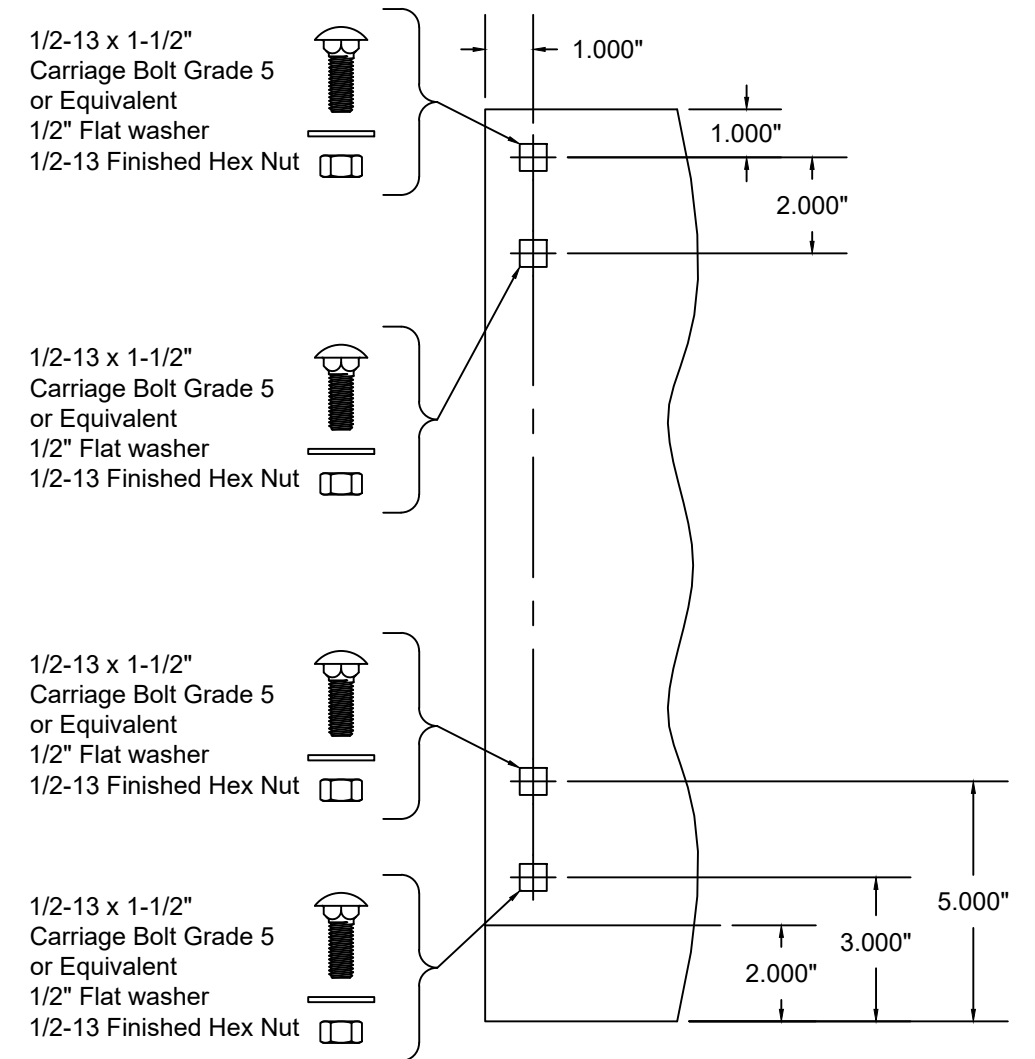

**12"Ø SHAFT ASSEMBLY**  
 17" AND LARGER COIL DIMENSION  
 MIN. THICKNESS 0.240" ASTM A36 STEEL  
 OR ASTM A480 STAINLESS STEEL,  
 TYPES 304 OR 316, MIN. 36 KSI YIELD STRENGTH  
 SCALE: 1-1/2" = 1'-0"



24 ELMWOOD AVE 1901 S. LITCHFIELD RD  
 MOUNTAINTOP, PA GOODYEAR, AZ  
 P: 800.390.8590  
 F: 866.448.6798  
 E: ADS@COOKSONDOOR.COM

Unless otherwise specified,  
 dimensions are in inches &  
 tolerances are:  
 0.000 = +/- 0.031  
 FRACTIONAL = +/- 1/32  
 ANGLES = +/- 1/2 DEG

TITLE: WIND LOAD CONFIGURATION HIGH PERFORMANCE INSULATED ROLLING STEEL DOOR CP0001/CP0651 SLAT IMPACT RATED	DRAWN BY: <b>CJR</b>	SIZE: <b>B</b>	SCALE: <b>AS NOTED</b>	SHEET: <b>6/8</b>
	DWG NO: <b>ES 16-101-TCCI</b>			

L'TR	REVISION	DATE	BY	E.C.O.
*	ORIGINAL ISSUE	04/20/20	CJR	1996

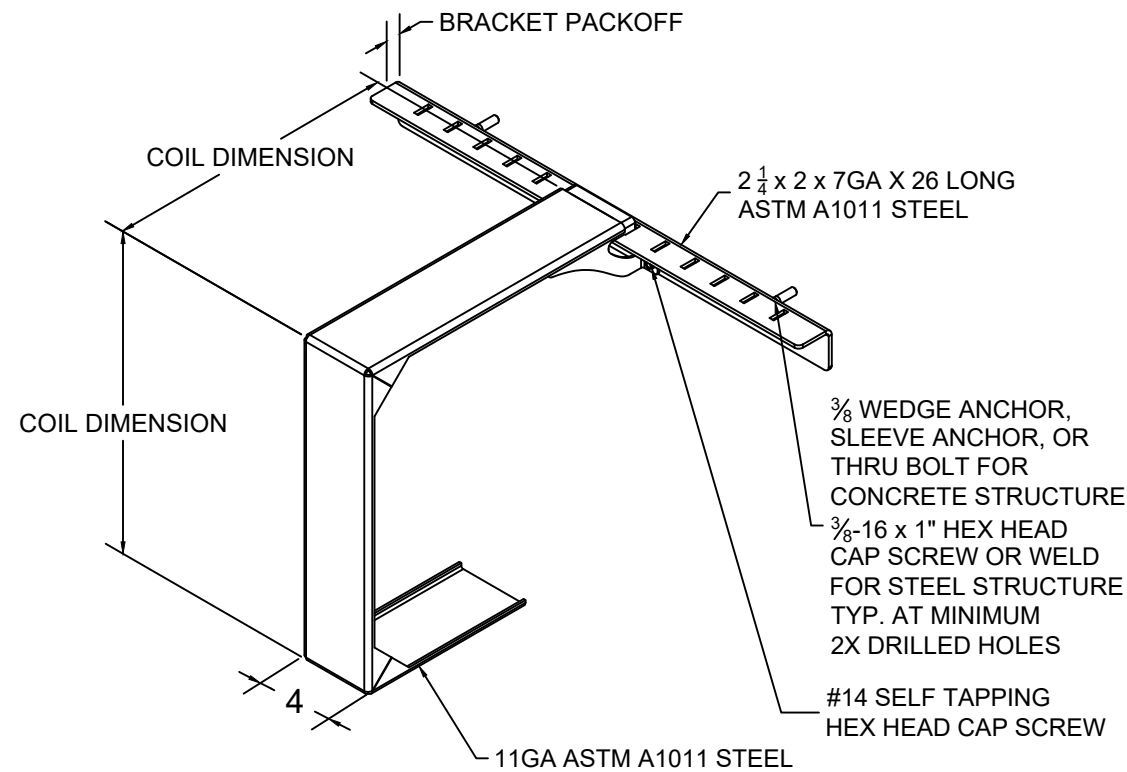

MID-HOOD SUPPORT  
(WHEN REQUIRED)  
SQUARE STYLE DEPICTED, "D" SHAPE ALSO AVAILABLE  
SCALE: NTS

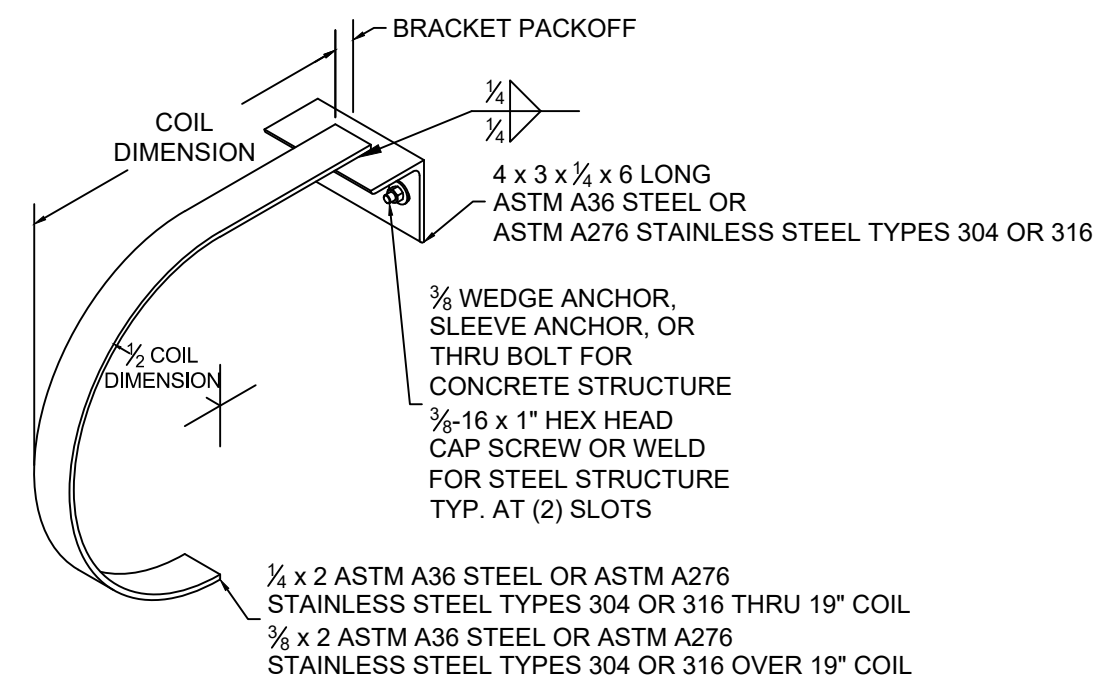

MID-HOOD SUPPORT  
(WHEN REQUIRED)  
"D" SHAPE DEPICTED, SQUARE STYLE ALSO AVAILABLE  
SCALE: NTS

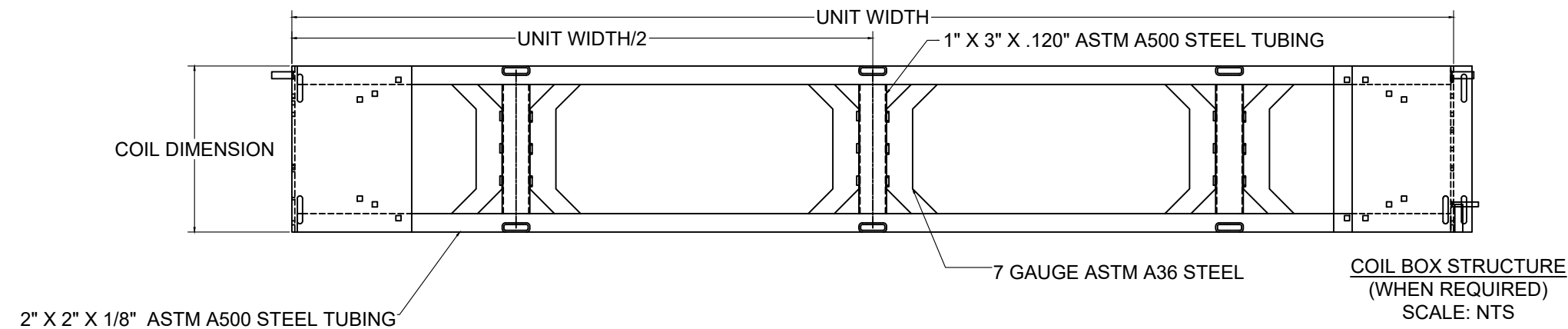

COIL BOX STRUCTURE  
(WHEN REQUIRED)  
SCALE: NTS



24 ELMWOOD AVE 1901 S. LITCHFIELD RD  
MOUNTAINTOP, PA GOODYEAR, AZ  
P: 800.390.8590  
F: 866.448.6798  
E: ADS@COOKSONDOOR.COM

Unless otherwise specified,  
dimensions are in inches &  
tolerances are:  
  
0.000 = +/- 0.031  
FRACTIONAL = +/- 1/32  
ANGLES = +/- 1/2 DEG

TITLE: WIND LOAD CONFIGURATION HIGH PERFORMANCE INSULATED ROLLING STEEL DOOR CP0001/CP0651 SLAT IMPACT RATED	DRAWN BY: <b>CJR</b>	SIZE: <b>B</b>	SCALE: <b>AS NOTED</b>	SHEET: <b>7/8</b>
	DWG NO: <b>ES 16-101-TCCI</b>			

L'TR	REVISION	DATE	BY	E.C.O.
*	ORIGINAL ISSUE	04/20/20	CJR	1996

CP0020 - GALVANIZED OR STAINLESS STEEL																	
									Concrete Minimum 3000psi Compressive Strength Concrete (anchors are the same diameter as assembly fasteners)								
Configuration	Minimum Front Slat Thickness	Maximum Pressure	Windlock Flat Location	Slip	Windlock	Windlock Weld Pitch	Assembly Fastener Diameter	Assembly Fastener Spacing	Hilti Kwik Bolt 3				Simpson Wedge All				
									Max O.C.	Embed	Min Wall Thick	Edge Dist.	Max O.C.	Embed	Min Wall Thick	Edge Dist.	
546	0.0405"	50 PSF	1.75"	0.781"	CP1413 & CP1514	8"	5/8"	18"	8"	4-3/8"	8"	8"	8"	8"	4-1/2"	6-3/4"	8"

Configuration	Concrete (cont.)				Filled CMU			Steel (Wall anchors sre the same diameter as assembly fasteners)					Superimposed Loads (at Maximum Pressure)			
	ITW Redhead Trubolt				Hilit Kwik HUS-EZ			Welded		Through Bolt	Tapped					
	Max O.C.	Embed	Min Wall Thick	Edge Dist.	Max O.C.	Embed	Edge Dist.	Max O.C.	Slot Size	Max O.C.	Max O.C.	Min Thickness	Vx(+)	Vy(+)	Vx(-)	Vy(-)
546	8"	4-5/8"	8"	8"	8"	5"	8"	14"	11/16" x 7/8"	14"	14"	3/8"	2700	699	2492	699



	24 ELMWOOD AVE 1901 S. LITCHFIELD RD MOUNTAINTOP, PA GOODYEAR, AZ P: 800.390.8590 F: 866.448.6798 E: ADS@COOKSONDOOR.COM	Unless otherwise specified, dimensions are in inches & tolerances are:  0.000 = +/- 0.031 FRACTIONAL = +/- 1/32 ANGLES = +/- 1/2 DEG			
	<b>TITLE:</b> WIND LOAD CONFIGURATION HIGH PERFORMANCE INSULATED ROLLING STEEL DOOR CP0001/CP0651 SLAT IMPACT RATED	<b>DRAWN BY:</b> CJR	<b>SIZE:</b> B	<b>SCALE:</b> AS NOTED	<b>SHEET:</b> 8/8
<b>DWG NO:</b> ES 16-101-TCCI					