

NOTES:

1. NON-IMPACT RESISTANT GLAZING OPTION - 3/32" MINIMUM SSB ANNEALED GLAZING IN MOLDED FRAMES SCREWED TOGETHER WITH A MINIMUM OF (14) #8x1" SCREWS (2X ALONG THE VERTICAL AND 5X ALONG THE HORIZONTAL) INSTALLED IN ANY OR ALL SECTIONS MEETS UNIFORM STATIC WIND PRESSURES SHOWN ON THIS DRAWING. MAXIMUM GLAZING DIMENSIONS SHALL BE 38.5" x 13" CLEAR OPENING. GLASS IS NOT IMPACT RESISTANT AND DOES NOT MEET THE REQUIREMENTS FOR WIND-BORNE DEBRIS REGIONS. SEE DETAIL E ON SHEET 2 FOR ASSEMBLY DETAILS.

ALTERNATE OPTION- 1/2" INSULATED DSB ANNEALED GLAZING IN ALUMINUM EXTERIOR FRAME/PLASTIC MOLDED INTERIOR FRAME SCREWED TOGETHER WITH A MINIMUM OF (14) #8x1" SCREWS (2X ALONG THE HORIZONTAL AND 5X ALONG THE HORIZONTAL) INSTALLED IN ANY OR ALL SECTIONS MEETS UNIFORM STATIC WIND PRESSURES SHOWN ON THIS DRAWING. MAXIMUM GLAZING DIMENSIONS SHALL BE 39" X 5-1/6" CLEAR OPENING. GLASS IS NOT IMPACT RESISTANT AND DOES NOT MEET THE REQUIREMENTS FOR WIND-BORNE DEBRIS REGIONS. SEE DETAIL F ON SHEET 2 FOR ASSEMBLY DETAILS.

2. VINYL OR WOOD DOOR STOP NAILED A MAXIMUM OF 6" O.C. MUST OVERLAP TOP AND BOTH ENDS OF PANELS MINIMUM 7/16" OR DOOR MAY OVERLAP JAMBS BY 1" ON EACH SIDE.

3. KEY LOCK, SLIDE LOCK, OR OPERATOR REQUIRED.

4. FACER STEEL TO HAVE A MINIMUM 27 GA THICKNESS AND BACKER STEEL TO HAVE A MINIMUM 29 GA THICKNESS.

5. THE DESIGN OF THE SUPPORTING STRUCTURAL ELEMENTS SHALL BE THE RESPONSIBILITY OF THE PROFESSIONAL OF RECORD FOR THE BUILDING OR STRUCTURE AND IN ACCORDANCE WITH CURRENT BUILDING CODES FOR THE LOADS LISTED ON THIS DRAWING.

6. DOOR JAMB TO BE MINIMUM 2x6 SOUTHERN PINE LUMBER. REFER TO JAMB CONNECTION SUPPLEMENT FOR ATTACHMENT TO SUPPORTING STRUCTURE.

7. FOR LOW HEAD ROOM LIFT CONDITIONS, TOP BRACKET SHALL BE A 13 GA LHR 7/4 TOP BRACKET WITH A MINIMUM OF (3) 1/4-14x7/8" SELF DRILLING CRIMPITITE SCREWS IN LIEU OF THE BRACKET SHOWN ON THIS DRAWING. U-BAR ON TOP SECTION SHALL BE INSTALLED ON TOP OF LHR TOP BRACKETS.

8. COMPLIES WITH THE REQUIREMENTS OF IBC/IRC 2018.

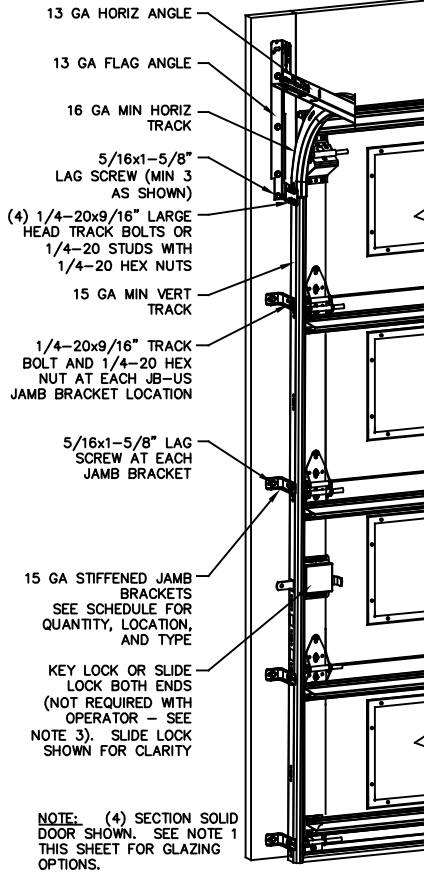

NOTE: (4) SECTION SOLID DOOR SHOWN. SEE NOTE 1 THIS SHEET FOR GLAZING OPTIONS.

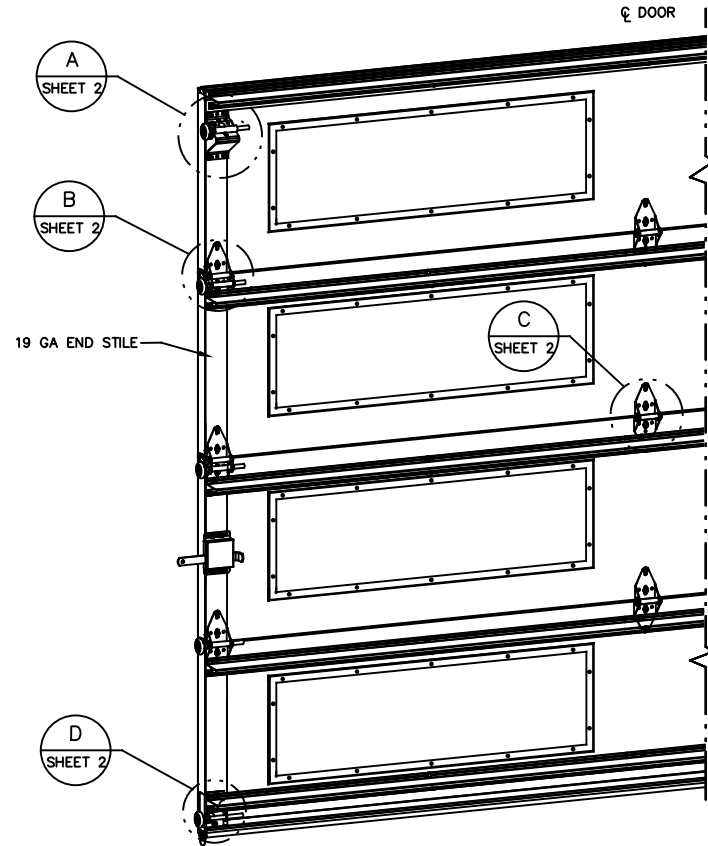

REVISIONS
REV - INITIAL DRAWING JQ 3/09/21

DOOR WIDTH	DOOR HEIGHT	UNIFORM LOAD EACH JAMB (PLF)
8'-2"	ALL	+75.1/-84.9
9'-2"	ALL	+84.3/-95.3

DOOR HEIGHT	NO. OF SECTIONS	NO. OF JAMB BRACKETS (EACH JAMB)	LOCATION OF CENTERLINE OF JAMB BRACKETS MEASURED FROM BOTTOM OF TRACK (ALL DIMENSIONS ± 2")
6'-6"	4	4	2" (JB-US), 21-3/4" (JB-US), 48" (JB-US), 57-1/4" (JB-US)
7'-0"	4	4	2" (JB-US), 21-3/4" (JB-US), 42" (JB-US), 63-1/4" (JB-US)
7'-6"	4 OR 5	4	2" (JB-US), 26-3/4" (JB-US), 45" (JB-US), 74-1/2" (JB-US)
8'-0"	4 OR 5	4	2" (JB-US), 21-3/4" (JB-US), 48" (JB-US), 75-1/2" (JB-US)
> 8'-0"			SEE NOTE BELOW

NOTE: (JB-US) FOLLOWING DIMENSION DENOTES SLOTTED JAMB BRACKET ATTACHED TO TRACK WITH 1/4-20x9/16" TRACK BOLT AND NUT AS SHOWN ABOVE. ALL DOORS GREATER THAN 8' IN HEIGHT REQUIRE USE OF CONTINUOUS WALL ANGLE. SEE SUPPLEMENT TRACK CHART FOR DETAILS.

JOHN E. SCATES, PE
2560 KING ARTHUR #124-54
LEWISVILLE, TX 75056
FL PE 51737
TX PE 56308/F2203
PROFESSIONAL ENGINEER'S SEAL PROVIDED ONLY FOR VERIFICATION OF WINDLOAD CONSTRUCTION DETAILS.

Wayne Dalton
GARAGE DOORS™
A DIVISION OF OVERHEAD DOOR CORP
3395 ADDISON DRIVE
PENSACOLA, FLORIDA 32514
(850) 474-9890

STATIC PRESSURE RATINGS		APPROVED SIZES	SCALE: N.T.S.	SIZE: A
DESIGN (PSF):	+18.40/-20.80	MAX WIDTH: 9'-2"	DATE	NAME
TEST (PSF):	+27.60/-31.20	MAX HEIGHT: 24'-0"	DRAWN	JQ
IMPACT/CYCLIC RATED (YES/NO): NO		MAX SECTION HEIGHT: 24"	CHECKED	DK
MODELS 4600/4650/6600/8300/8350/8500/5150/5200			SHEET 1 OF 2	
WINDLOAD SPECIFICATION OPTION CODE 2601			DRAWING PART NO.	REV.
			365434	-

13 GA ROLLER SLIDE ATTACHED TO BRACKET WITH 5/16-18 BOLT & NUT IN CENTER SLOT AND 1/4-20x9/16" TRACK BOLT & 1/4-20 HEX NUT THROUGH ANY TWO ALIGNING HOLES

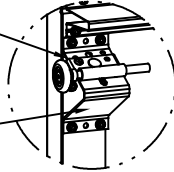

DETAIL A

13 GA COMMERCIAL 'A' FRAME TOP BRACKET ATTACHED WITH (4) 1/4-14x7/8" SELF DRILLING CRIMPTITE SCREWS

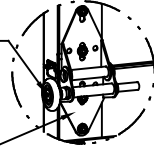

DETAIL B

2" STEEL ROLLER WITH 5-1/4" STEM. OPTIONAL- 11 BALL BEARING NYLON ROLLER.

WIDE BODY END HINGE ATTACHED WITH (4) 1/4-14x7/8" SELF DRILLING CRIMPTITE SCREWS

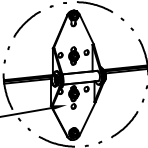

DETAIL C

SINGLE END HINGE
#1 HINGE 14GA
#2 HINGE 13GA
#3 HINGE 13GA

14 GA WIDE BODY INTERMEDIATE HINGE ATTACHED WITH (4) 1/4-14x7/8" SELF DRILLING CRIMPTITE SCREWS

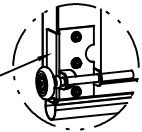

DETAIL D

14 GA BOTTOM BRACKET ATTACHED WITH (2) 1/4-14x7/8" SELF DRILLING CRIMPTITE SCREWS AND (1) 1/4-14x5/8" SELF DRILLING TAMPER RESISTANT SCREW

1/8" BEAD OF BOSTICK 1100 OR EQUIVALENT

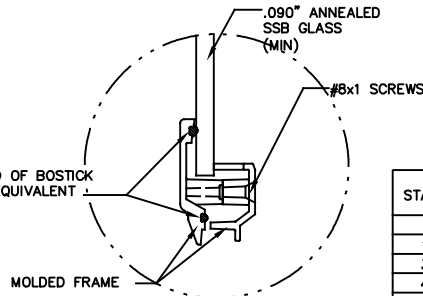

PLASTIC FRAME (STATIC RATED) DETAIL E

STATIC FRAME SIZE	DAYLIGHT OPENING (DLO)	SCREW QTY
18.74 X 13.76	15 X 11	10
18.25 X 15.25	15.75 X 12.75	6
39.88 X 12.69	35.8 X 8.6	14
40.50 X 15.25	37.8 X 12.75	14
40.75 X 7	37.75 X 4	14
43.96 X 15.09	40.13 X 11.25	22

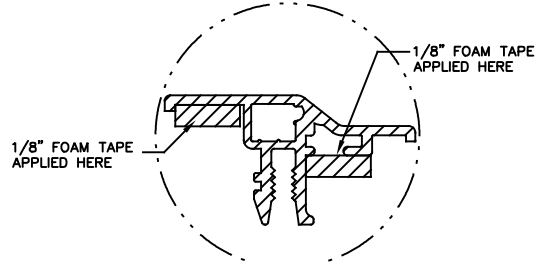

ALUMINUM FRAME (STATIC RATED ALTERNATE FRAME OPTION) DETAIL F

ALL U-BARS SHALL BE ATTACHED WITH (2) 1/4-14x7/8" SELF DRILLING CRIMPTITE SCREWS AT EACH HINGE LOCATION AND BETWEEN ALL END HINGES AND INTERMEDIATE HINGES. A MINIMUM OF (10) FASTENERS ARE TO BE USED.

(4) SECTION DOORS WITH (5) 2" 20 GA 80 KSI U-BARS LOCATED AS SHOWN

(5) SECTION DOORS WITH (6) 2" 20 GA 80 KSI U-BARS LOCATED AS SHOWN

(6) SECTION DOORS WITH (7) 2" 20 GA 80 KSI U-BARS LOCATED AS SHOWN

(7) SECTION DOORS WITH (8) 2" 20 GA 80 KSI U-BARS LOCATED AS SHOWN

(8) SECTION DOORS WITH (9) 2" 20 GA 80 KSI U-BARS LOCATED AS SHOWN

(9) SECTION DOORS WITH (10) 2" 20 GA 80 KSI U-BARS LOCATED AS SHOWN

(10) SECTION DOORS WITH (11) 2" 20 GA 80 KSI U-BARS LOCATED AS SHOWN

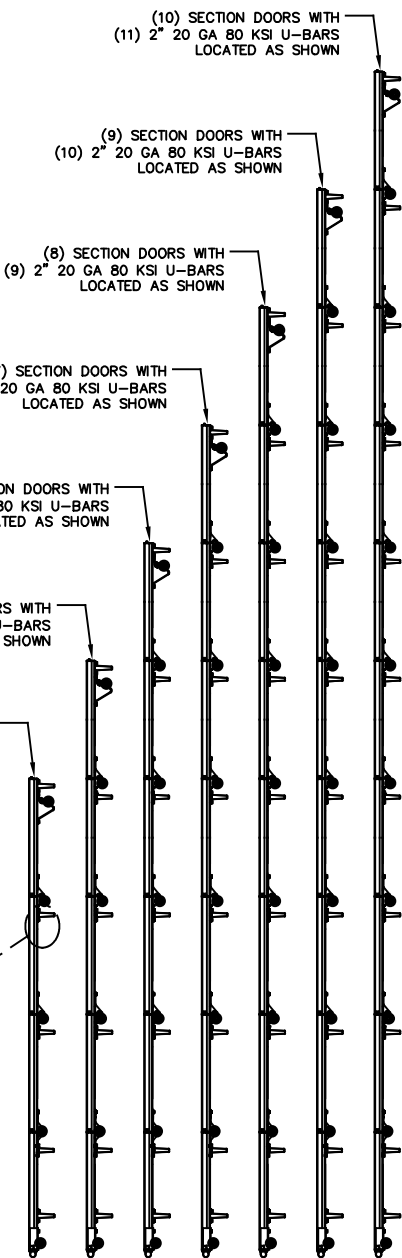
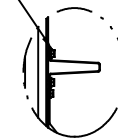

JOHN E. SCATES, PE
2560 KING ARTHUR #124-54
LEWISVILLE, TX 75056
FL PE 51737
TX PE 56308/F2203
PROFESSIONAL ENGINEER'S SEAL PROVIDED ONLY FOR VERIFICATION OF WINDLOAD CONSTRUCTION DETAILS.

Wayne Dalton
GARAGE DOORS™
A DIVISION OF OVERHEAD DOOR CORP
3395 ADDISON DRIVE
PENSACOLA, FLORIDA 32514
(850) 474-9890

STATIC PRESSURE RATINGS		APPROVED SIZES		SCALE: N.T.S.		SIZE: A	
DESIGN (PSF):	+18.40/-20.80	MAX WIDTH:	9'-2"	DATE	NAME		
TEST (PSF):	+27.60/-31.20	MAX HEIGHT:	24'-0"	DRAWN	JQ		
IMPACT/CYCLIC RATED (YES/NO): NO		MAX SECTION HEIGHT:	24"	CHECKED	DK		
MODELS 4600/4650/6600/8300/8350/8500/5150/5200				SHEET 2 OF 2			
WINDLOAD SPECIFICATION OPTION CODE 2601				DRAWING PART NO.		REV.	
				365434		-	