

DOORKRAFT,LLC  
 1625 Crescent Circle  
 Suite 225  
 Carrollton,TX 75006

# RESIDENTIAL CEDAR WOOD DOOR WINDLOAD 2

DRAWING No. 18' x 7' WL2	
SHEET No. 1 OF 2	
DRAWN BY: JKL	DATE: 05-18-2020
REVISION HISTORY: REVISED TO NEW STANDARDS	REV. 5.18.2020
ORIGINAL DRAWING	ORG.DATE 10.2.2019

SCALE: NONE	DESIGN PRESSURES +21.6 -24.1	TESTING STANDARDS: DASMA 108-05/12/17	DOOR DISTRIBUTOR: DOORKRAFT LLC
-------------	------------------------------	---------------------------------------	---------------------------------

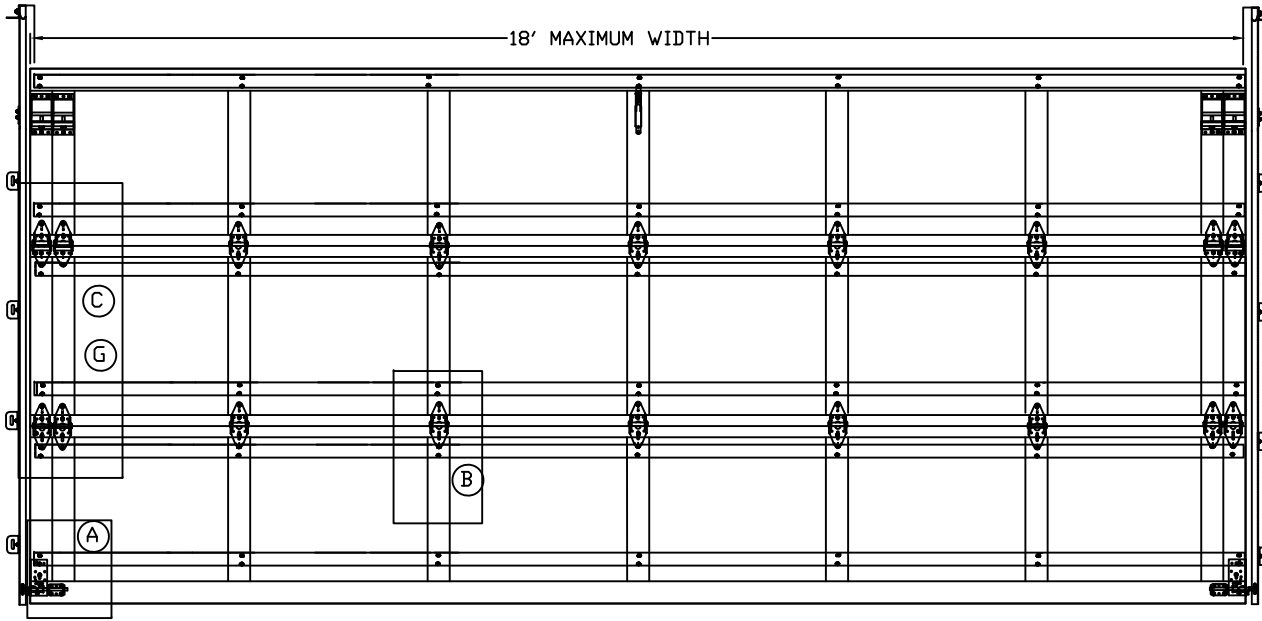

INTERIOR ELEVATION

7' TALL DOOR 3 QTY 28" SECTIONS  
 8' TALL DOOR 4 QTY 24" SECTIONS

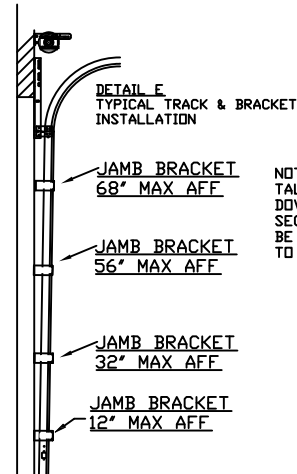

NOTE: SPACING SHOWN FOR SINGLE DOOR 7' TALL TRACK SPACING MAY BE ADJUSTED DOWNWARD FOR TALLER DOORS OR SHORTER SECTION HEIGHTS. ADDITIONAL BRACKETS MAY BE NEEDED FOR TALLER DOORS. SPACING NOT TO EXCEED 24".

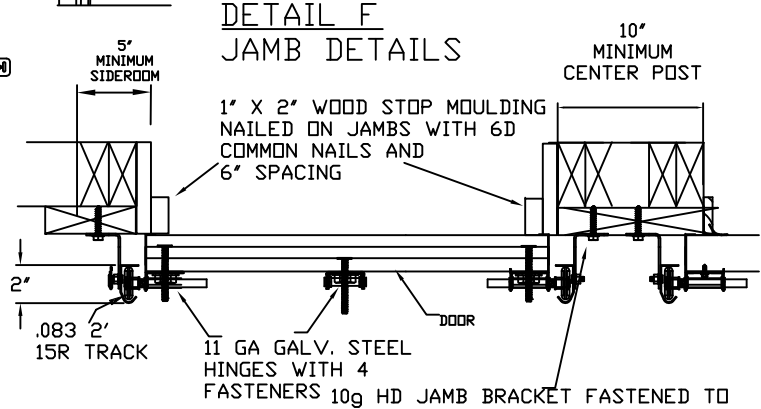

DETAIL F JAMB DETAILS

NOTE: ALL ROLLERS ARE DETAIL Q ON PAGE 2

DETAIL B INTERIOR STILES TYPICAL SECTION CONSTRUCTION

DETAIL C TYPICAL SECTION CONSTRUCTION

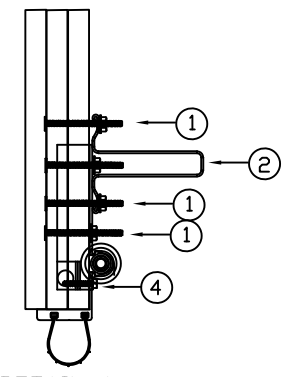

DETAIL A TYPICAL BOTTOM SECTION CONSTRUCTION

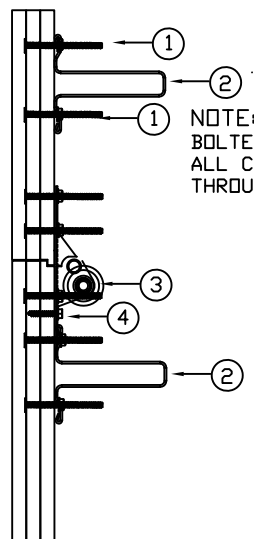
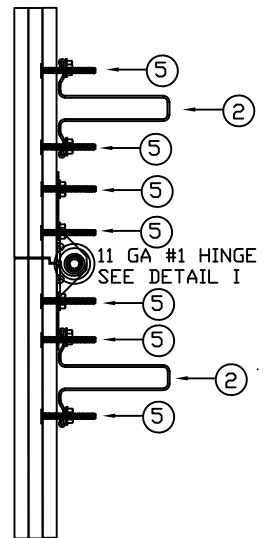

NOTE: ALL HARDWARE ON END STILES THROUGH BOLTED THROUGH FRAME AND TONGUE & GROOVE BOARD. ALL CENTER STILE HARDWARE THROUGH BOLTED ONLY THROUGH FRAME

- ⑤ 1/4-20 X 1-7/8" FLAT HEAD CARRIAGE BOLT WITH 1/4-20 SERRATED FLANGE NUT
- ④ 5/16" X 1-5/8" HH LAG SCREW WITH WASHER HEAD
- ③ 11 GAUGE HINGE #1,#2,#3 (DETAIL I,J,K)
- ② 3' X 17'-11" STRUT HD 17GA (DETAIL U)
- ① 1/4-20 X 2-1/4" FLAT HEAD CARRIAGE BOLT WITH 1/4-20 SERRATED FLANGE NUT

10g HD JAMB BRACKET FASTENED TO WOOD JAMBS WITH 5/16" X 1-3/4" LAG SCREW WITH WASHER HEAD. FASTEN TO TRACK WITH 1/4" TRACK BOLTS AND NUTS. PREPARATION OF JAMBS BY OTHERS SEE DETAIL E FOR SPACING

John E. Scates, P.E.  
 2560 King Arthur #124-54  
 Lewisville, TX 75056

DOORKRAFT,LLC

1625 Crescent Circle  
Suite 225  
Carrollton, TX 75006

# RESIDENTIAL CEDAR WOOD DOOR WINDLOAD 2

DRAWING No. 1  
18' x 7' WL2

SHEET No. 2 OF 2

SCALE:  
NONE

DESIGN  
PRESSURES

+21.6

-24.1

TESTING STANDARDS:

DASMA 108-05/12/17

DOOR DISTRIBUTOR:

DOORKRAFT LLC

DRAWN BY: JKL

DATE: 05-18-2020

DETAIL I  
11 GA #1 HINGE



DETAIL J  
11 GA #2 HINGE

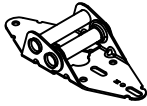

DETAIL K  
11 GA #3 HINGE



DETAIL L  
10 GA HDJAMB  
BRACKET 4-1/4"



DETAIL M  
10 GA HDJAMB  
BRACKET 5-1/2"

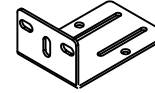

DETAIL N  
COMMERCIAL TOP BRACKET  
ARROW TRU-LINE PART:853ADJTFCO



DETAIL S  
ROLLER CARRIER  
NAPOLEAN LYNX PART#3-44-1

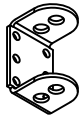

DETAIL Q  
2" NYLON PRECISION BEARING  
HIGH STRENGTH ROLLER  
9-1/2" ZINC PLATED HIGH STRENGTH STEM  
100LB. LOAD

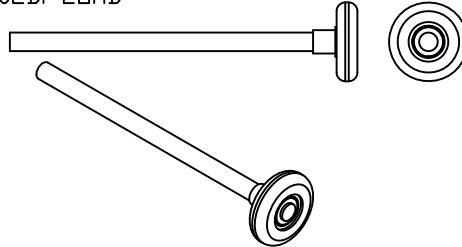

DETAIL R  
BB-100 BOTTOM BRACKET  
NAPOLEAN LYNX PART: 3-37-1

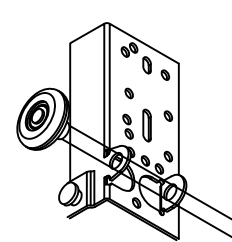

DETAIL V  
3-3/8" CENTER SUPPORT  
11GA W/BRG

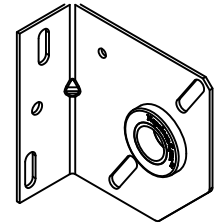

DETAIL G  
TYPICAL END STILE  
ATTACHMENT

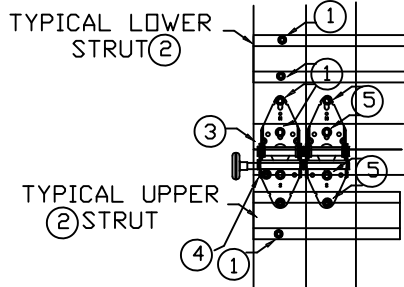

(through bolted  
through frame  
and t&g)

DETAIL U  
3" 17'-11" STRUT HD 17GA 50KSI  
STRUTS TO BE THROUGH-BOLTED TO EACH STYLE  
WITH 1/4-20X 1-7/8" FH CARRIAGE BOLTS TO CENTER STILES  
AND 1/4-20 X 2-1/4" FH CARRIAGE BOLTS AT END STILES  
ON MODEL WL-1 CENTER STRUTS TO BE ATTACHED  
WITH 5/8" X 1- 3/8" LAG SCREW WITH  
WASHER HEAD

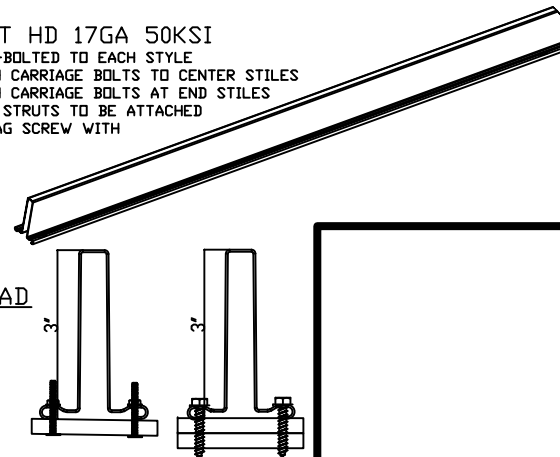

- ⑤ 1/4-20 X 1-7/8" FLAT HEAD CARRIAGE BOLT WITH 1/4-20 SERRATED FLANGE NUT
- ④ 5/8-16 X 1-5/8" HH LAG SCREW WITH WASHER HEAD
- ③ 11 GAUGE HINGE #1,#2,#3
- ② 3" X 17'-11" STRUT HD 17GA
- ① 1/4-20 X 2-1/4" FLAT HEAD CARRIAGE BOLT WITH 1/4-20 SERRATED FLANGE NUT

John E. Scates, P.E.  
2560 King Arthur #124-54  
Lewisville, TX 75056