

Section A-A

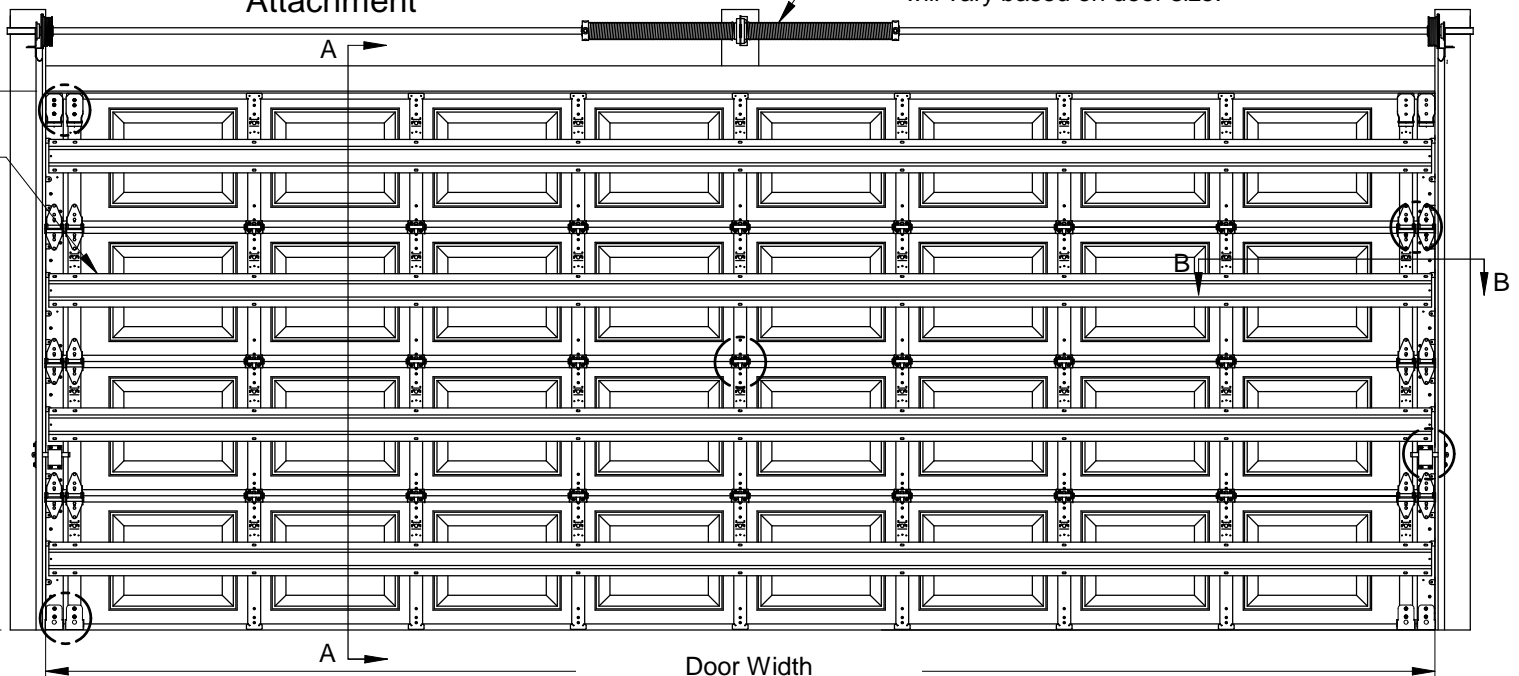

Doors tested per ANSI/DASMA 108 for static air pressure and ANSI/DASMA 115 for large missile impact and cyclic wind pressure

Max. Door Width	Colonial			Ranch			Carriage House		
	Stiles per Sect.	Hinges per Sect.	Design Loads	Stiles per Sect.	Hinges per Sect.	Design Loads	Stiles per Sect.	Hinges per Sect.	Design Loads
8'-0"	3	3	37.4 -41.7	3	3	37.4 -41.7	3	3	37.4 -41.7
9'-0"	3	3		3	3				
10'-0"	4	4		3	3				
12'-0"	5	5		5	5				
14'-0"	6	6		5	5				
16'-0"	7	7		7	7				
18'-0"	7	7	7	7					

John E. Scates  
2560 King Arthur Blvd, Ste 124-54  
Lewisville, TX 75056  
FL PE #51737  
TX PE #56308-42203

Rev.	Description	ECO	Date	ECO: 7679.01
B	Removed vent option on sheet 1.	7679.04	12/09/19	
A	New release for production.	7679.01	02/18/19	

Scale: None

Drawn by: R. Frey

Checked by: G. Wedekind

Date: 02/18/19

ECO: 7679.01

**RAYNOR**

1101 East River Road  
Dixon, IL. 61021

Title: Spec, Wind Load BuildMark / TradeMark

No. P-2905

Sheet 1 of 3

Rev B

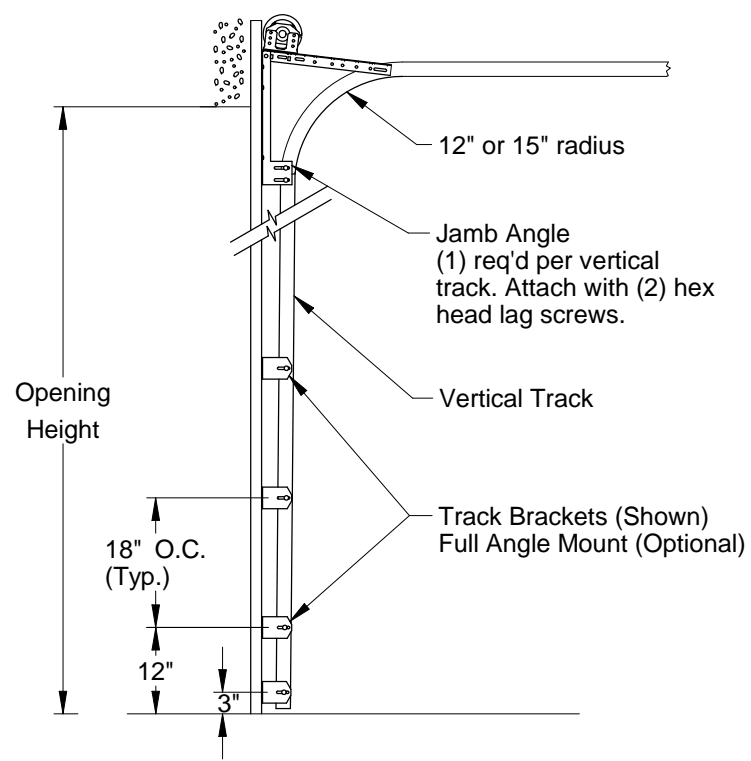

**Typical Track Installation**  
Normal headroom track shown, low headroom, lift clearance and vertical lift track available

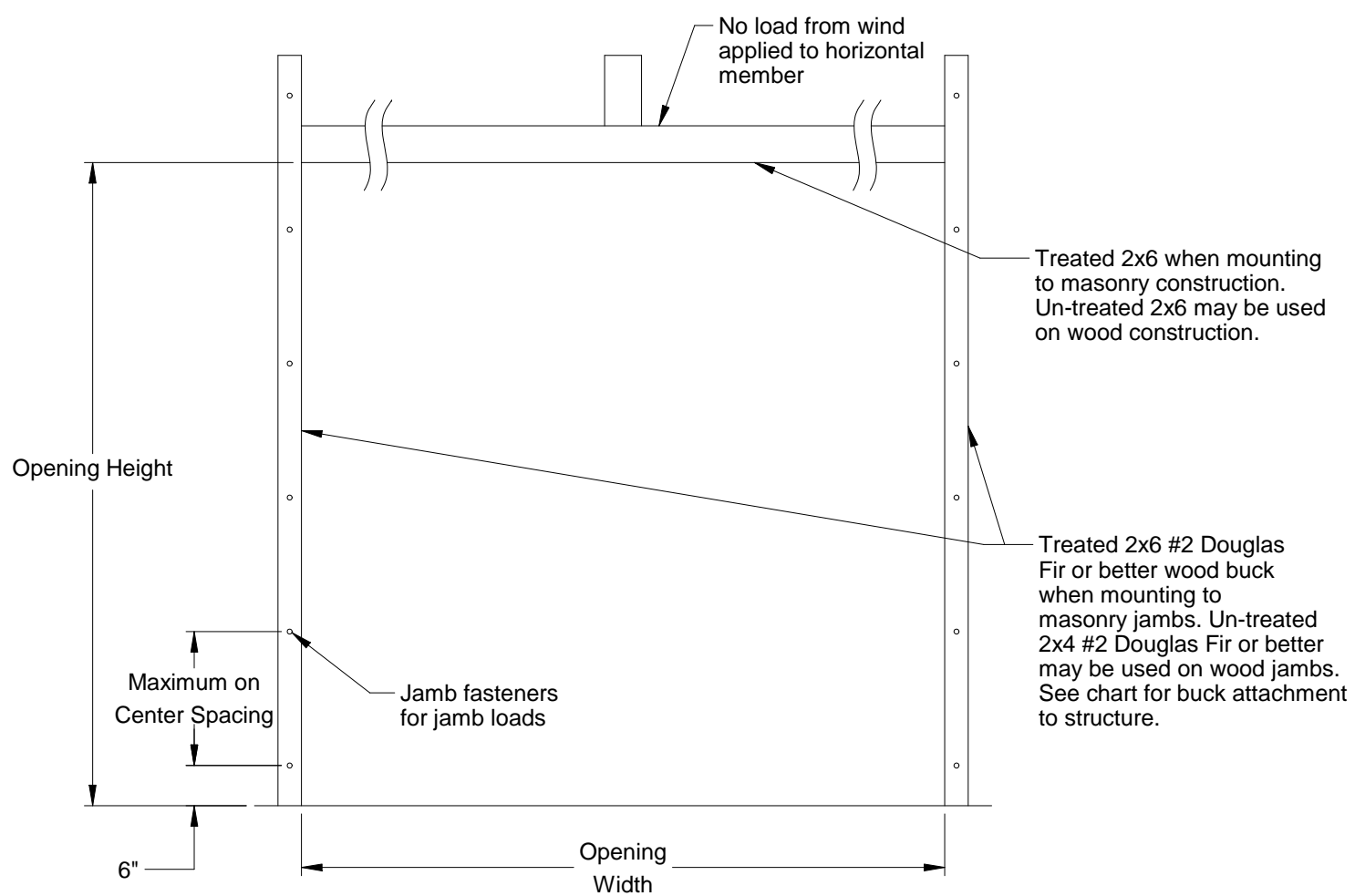

**Jamb Attachment Notes:**

1. Maximum Positive Load per Jamb =  $(18'-0" \times 37.4 \text{ PSF}) / 2 = 337 \text{ lbs. per foot.}$
2. Maximum Negative Load per Jamb =  $(18'-0" \times -41.7 \text{ PSF}) / 2 = 376 \text{ lbs. per foot.}$
3. Design of the supporting structure shall be the sole responsibility of the building designer and shall be designed for the jamb loads listed in notes 1 and 2.
4. Alternate jamb attachments may be used if approved by a registered Professional Engineer.
5. DASMA Technical Data Sheet TDS-161 may be used for alternate jamb attachments.
6. 3/8" diameter lag screws required 1/16" pilot hole and 1-1/2" minimum required distance.

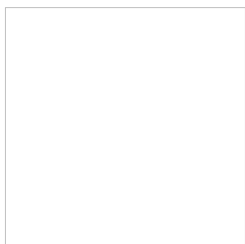

John E. Scates  
2560 King Arthur Blvd, Ste 124-54  
Lewisville, TX 75056  
FL PE #51737  
TX PE #56308-f2203

2x6 Attachment to Structure						
Structure Type	Fastener Type	Minimum Embedment	Minimum Edge Distance	Minimum on Center Spacing	Maximum on Center Spacing	Allowable Tension Load
2500 PSI Min. Concrete	1/4" Tapcon+ (Plus) with 1-1/8" OD Washer	2"	2.5"	6"	18"	526
Southern Pine	3/8" x 3" Lag with 1-1/8" OD Washer	1.50"	1.50"	1.50"	23"	655
Spruce Pine Fir	3/8" x 3" LAG with 1-1/8" OD Washer	1.50"	1.50"	1.50"	17"	482

Scale: None
Drawn by: R. Frey
Checked by: G. Wedekind
Date: 02/18/19
ECO: 7679.01



1101 East River Road  
Dixon, IL. 61021

Title: Spec, Wind Load BuildMark / TradeMark		
No. P-2905	Sheet 2	Rev B

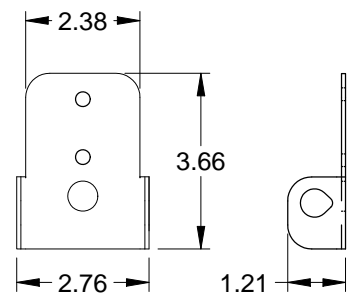

Roller Carrier  
.086 Galv. Steel

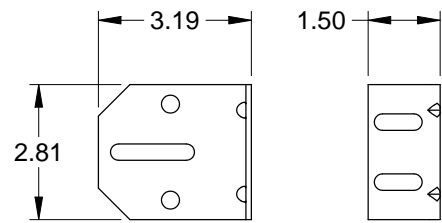

3" Track Bracket  
.116 Galv. Steel

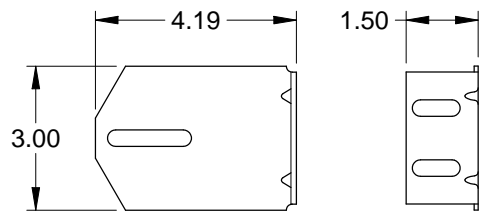

4" Track Bracket  
.116 Galv. Steel

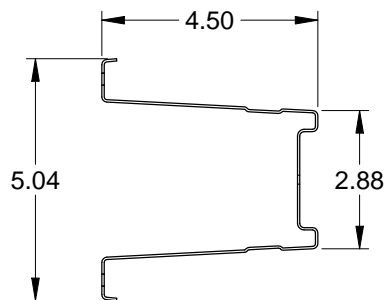

Steel Box Strut  
20 Ga. (.035" Min.) Galvanized  
High Tensile Steel  
80 KSI Minimum Yield

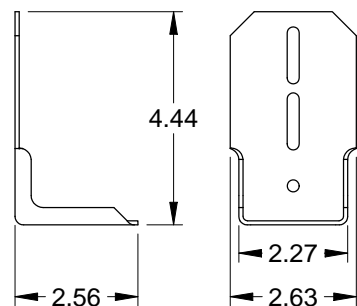

Top Fixture  
.086 Galv. Steel

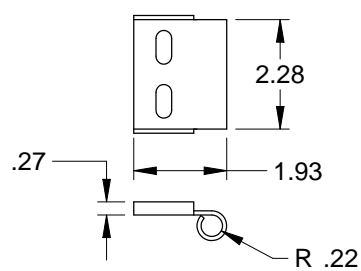

Roller Carrier  
.116 Galv. Steel  
Attached to Top Fixture  
w/(2) Track Bolts and Whiz Nuts

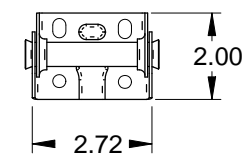

Center Hinge  
.045 Galv. Steel

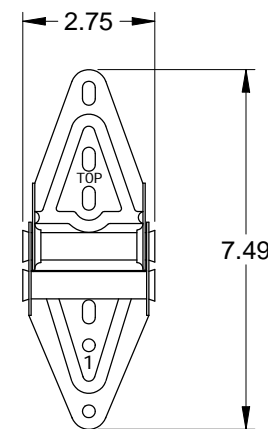

Edge Hinge  
.086 Galv. Steel

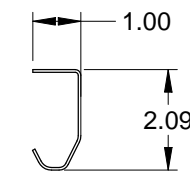

2" Track  
.086 Galv. Steel

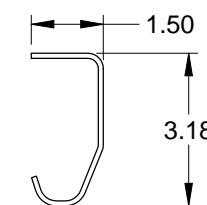

3" Track (Optional)  
.105 Galv. Steel

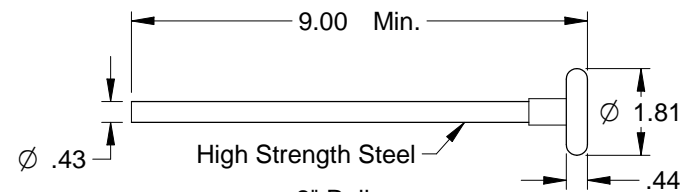

2" Roller  
Nylon Precision Bearing (Std.)  
Steel 10-ball High (Opt.)

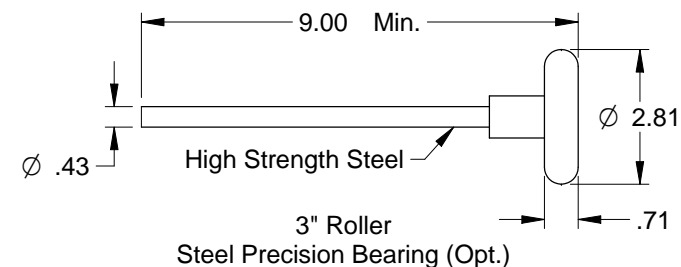

3" Roller  
Steel Precision Bearing (Opt.)

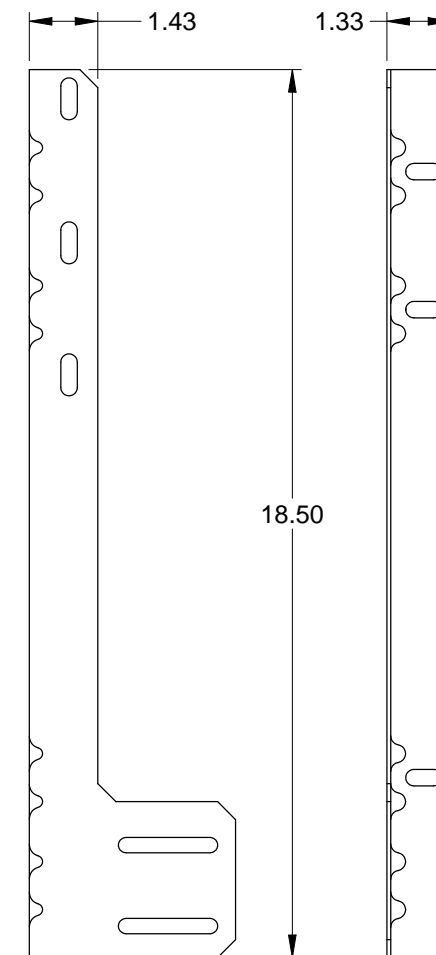

Jamb Angle  
.078 Galv. Steel

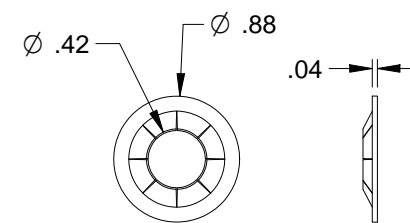

Retaining Nut

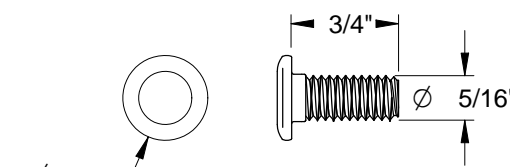

Track Bolt

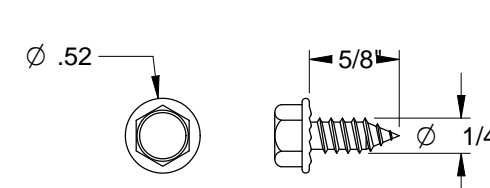

Sheet Metal Screw

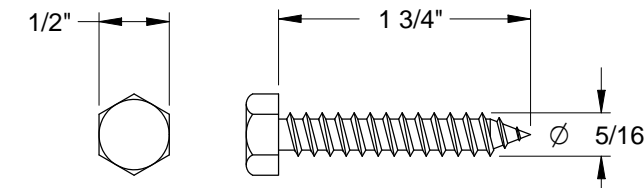

Hex Head Lag Screw

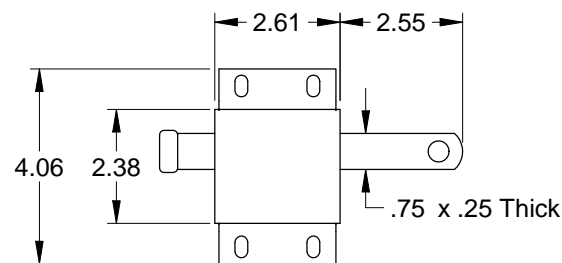

Slide Lock  
Case .086 Galv. Steel

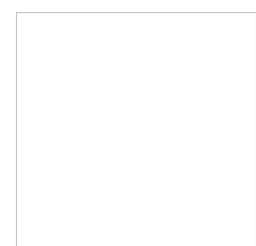

John E. Scates  
2560 King Arthur Blvd, Ste 124-54  
Lewisville, TX 75056  
FL PE #51737  
TX PE #56308-f2203

Scale: None	 1101 East River Road Dixon, IL 61021	Title: Spec, Wind Load BuildMark / TradeMark	
Drawn by: R. Frey		No. P-2905	Sheet 3
Checked by: G. Wedekind			Rev B
Date: 02/18/19		ECO: 7679.01	