

Interior Skin
.013 thick G-40 galvanized steel with an epoxy primer and baked on polyester finish which is roll-formed with wood grain texture.

Exterior Skin
.014 thick G-40 galvanized steel with an epoxy primer and baked on polyester finish which is roll-formed with wood grain texture.

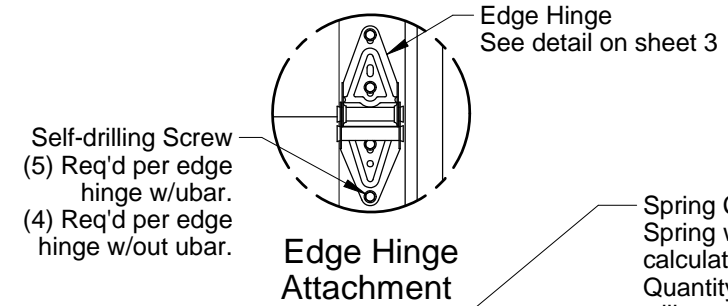
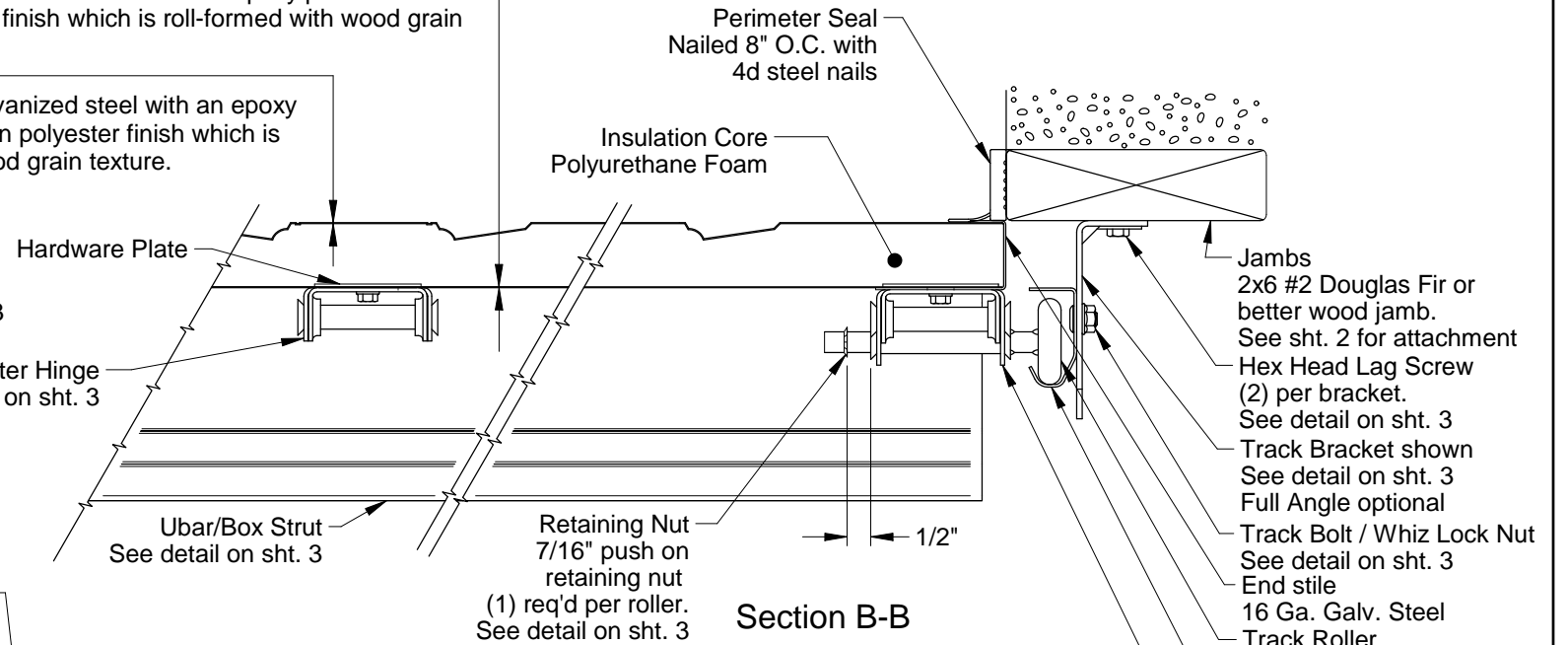

Section A-A

Doors tested per ANSI/DASMA 108 for static air pressure and ANSI/DASMA 115 for large missile impact and cyclic wind pressure

AP138 / AP138C							
Max. Door Width	Colonial		Ranch		Carriage House		
	Hinges per Section	Design Loads	Hinges per Section	Design Loads	Hinges per Section	Design Loads	
8'-0"	1	55.0 -62.0	1	55.0 -62.0	1	55.0 -62.0	
9'-0"	1	55.0 -62.0	1	55.0 -62.0	1	55.0 -62.0	
10'-0"	2	39.1 -43.5	1	39.1 -43.5	1	39.1 -43.5	
12'-0"	2	39.1 -43.5	2	39.1 -43.5	2	39.1 -43.5	
14'-0"	4	29.7 -33.1	2	29.7 -33.1	2	29.7 -33.1	
16'-0"	3	29.7 -33.1	3	29.7 -33.1	3	29.7 -33.1	

AP200 / AP200C							
Max. Door Width	Colonial		Ranch		Carriage House		
	Hinges per Section	Design Loads	Hinges per Section	Design Loads	Hinges per Section	Design Loads	
8'-0"	1	60.0 -65.0	1	60.0 -65.0	1	60.0 -65.0	
9'-0"	1	60.0 -65.0	1	60.0 -65.0	1	60.0 -65.0	
10'-0"	2	42.8 -47.6	1	42.8 -47.6	1	42.8 -47.6	
12'-0"	2	42.8 -47.6	2	42.8 -47.6	2	42.8 -47.6	
14'-0"	4	32.5 -35.9	2	32.5 -35.9	2	32.5 -35.9	
16'-0"	3	32.5 -35.9	3	32.5 -35.9	3	32.5 -35.9	

Door Height
7'-0" High shown
Other door heights available up to 10'-0" using 18" or 21" high sections

Windows (Optional)
See options on sht. 2
One row maximum

Steel Reinforcement
(1) Box strut per section,
(2) U-bar on window section fastened to all center and end stiles using (2) self-drilling screws at each stile.

Locks required on doors not electrically operated.

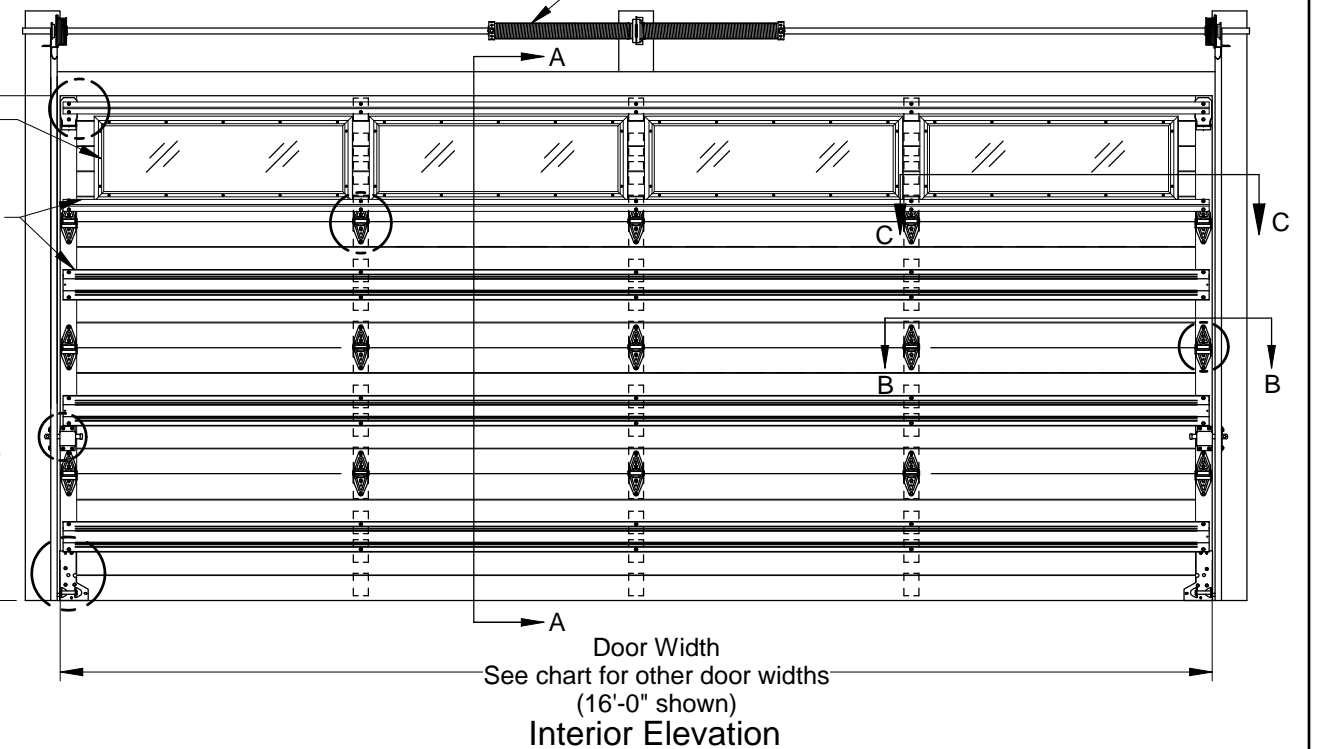

John E. Scates
2560 King Arthur Blvd, Ste 124-54
Lewisville, TX 75056
FL PE #51737
TX PE #56308-f2203

Rev.	Description	ECO	Date	ECO: 7679.01
B	Removed vent option on sheet 1.	7679.04	12/09/19	
A	New release for production.	7679.01	02/07/19	

Scale: None
Drawn by: R. Frey
Checked by: G. Wedekind
Date: 02/07/19



1101 East River Road
Dixon, IL 61021

Title: Spec, Wind Load Aspen Series	
No. P-2900	Sheet 1 of 3
Rev B	

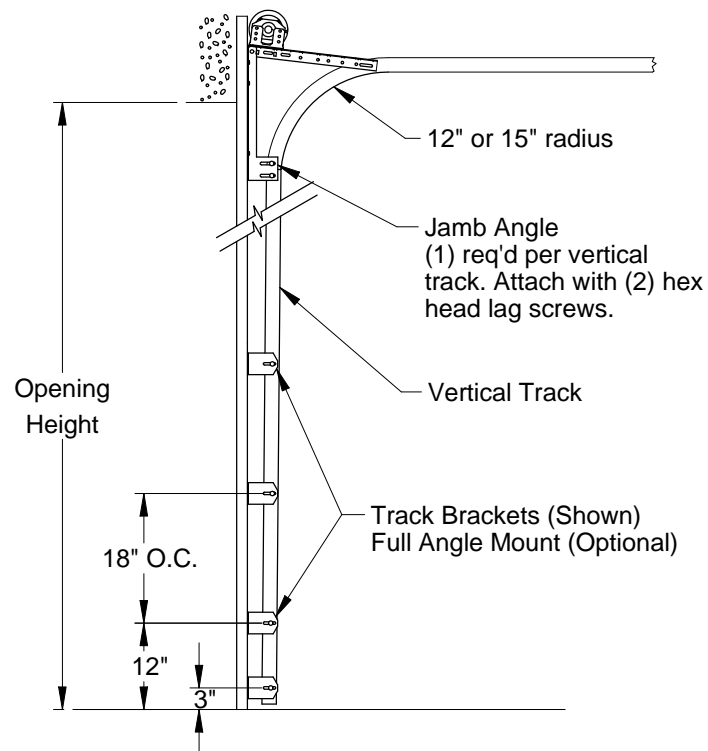

Typical Track Installation
 Normal headroom track shown, low headroom, lift clearance and vertical lift track available

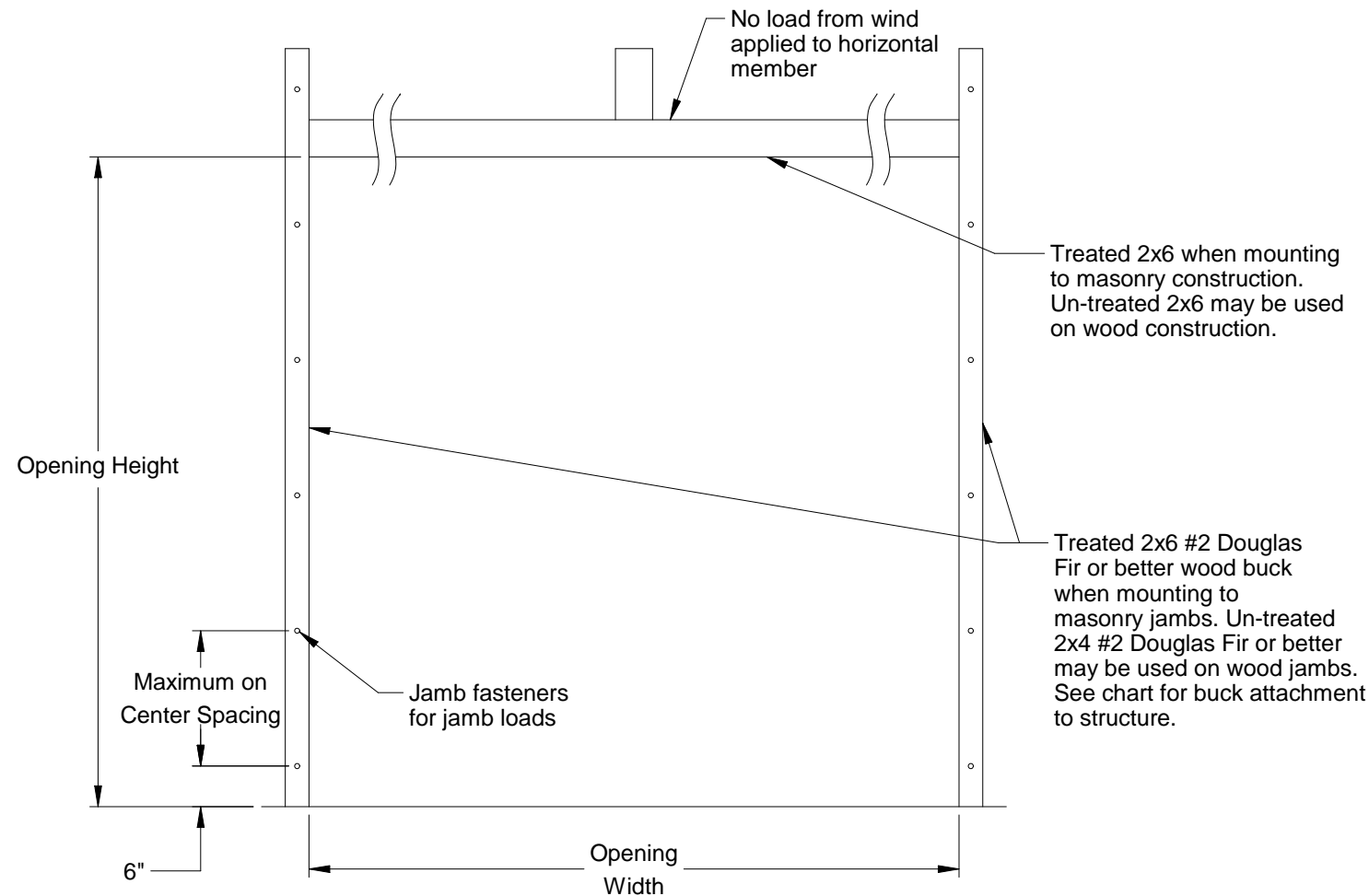

Jamb Attachment Notes:

1. Maximum Positive Load per Jamb = (9'-0" x 60.0 PSF) / 2 = 270 lbs. per foot.
2. Maximum Negative Load per Jamb = (9'-0" x -65.0 PSF) / 2 = 293 lbs. per foot.
3. Design of the supporting structure shall be the sole responsibility of the building designer and shall be designed for the jamb loads listed in notes 1 and 2.
4. Alternate jamb attachments may be used if approved by a registered Professional Engineer.
5. DASMA Technical Data Sheet TDS-161 may be used for alternate jamb attachments.
6. 3/8" diameter lag screws required 1/16" pilot hole and 1-1/2" minimum required distance.

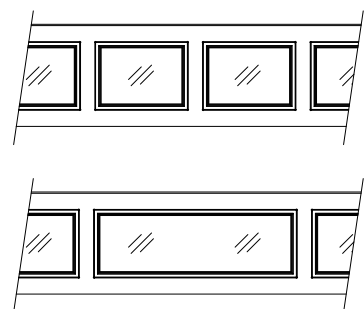

Window Options

2x6 Attachment to Structure						
Structure Type	Fastener Type	Minimum Embedment	Minimum Edge Distance	Minimum on Center Spacing	Maximum on Center Spacing	Allowable Tension Load
2500 PSI Min. Concrete	1/4" Tapcon+ (Plus) with 1-1/8" OD Washer	2"	2.5	6"	23"	526
Southern Pine	3/8" x 3" Lag with 1-1/8" OD Washer	1.50"	1.50"	1.50"	24"	655
Spruce Pine Fir	3/8" x 3" LAG with 1-1/8" OD Washer	1.50"	1.50"	1.50"	21"	482

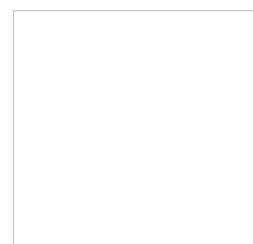

John E. Scates
 2560 King Arthur Blvd, Ste 124-54
 Lewisville, TX 75056
 FL PE #51737
 TX PE #56308-f2203

Scale: None	 1101 East River Road Dixon, IL. 61021	Title: Spec, Wind Load Aspen Series		
Drawn by: R. Frey		No. P-2900	Sheet 2	Rev B
Checked by: G. Wedekind				
Date: 02/07/19				
ECO: 7679.01				

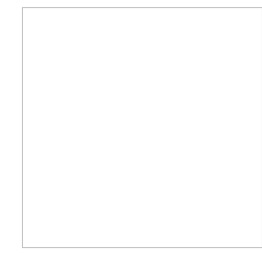
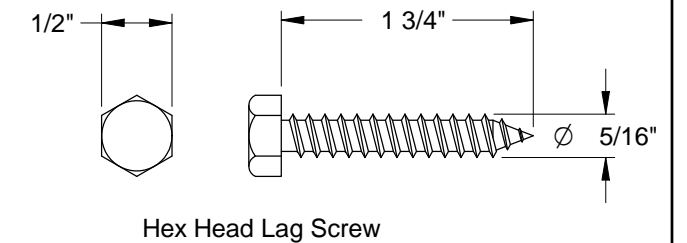
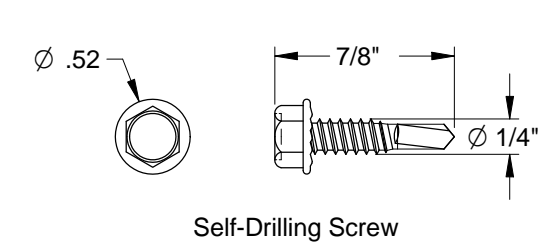
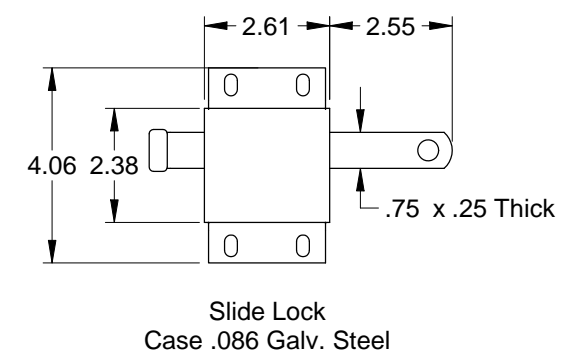
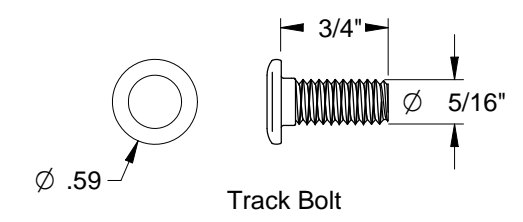
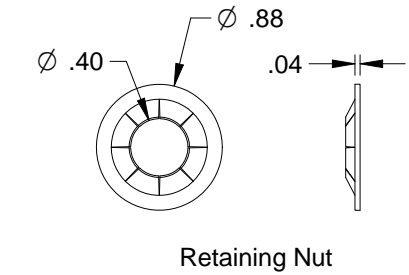
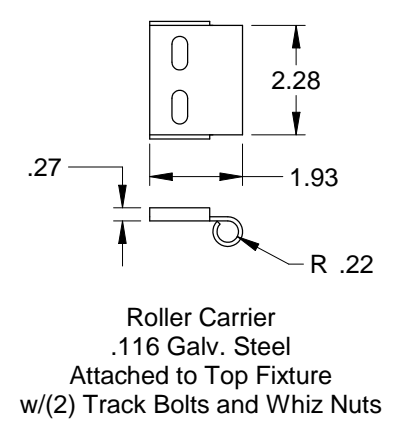
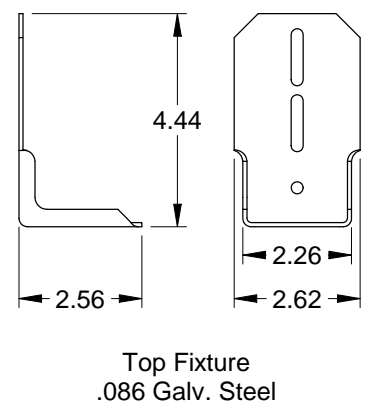
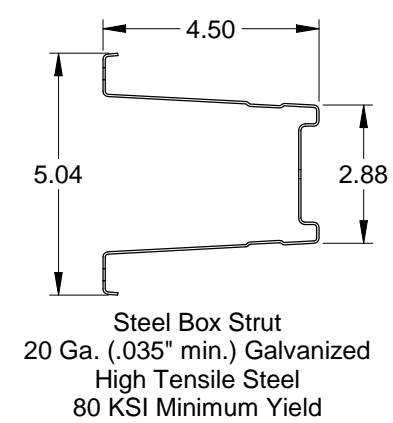
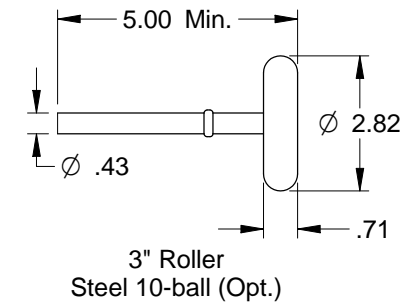
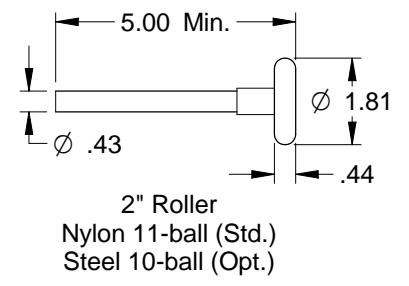
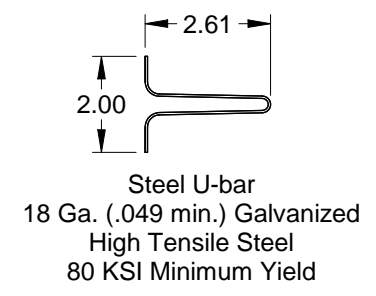
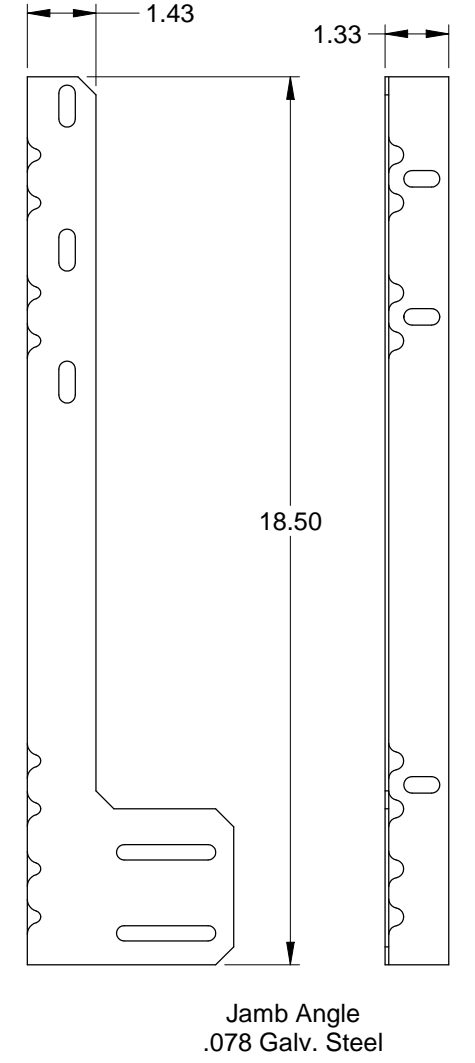
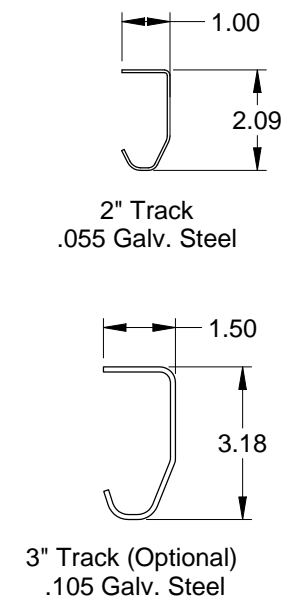
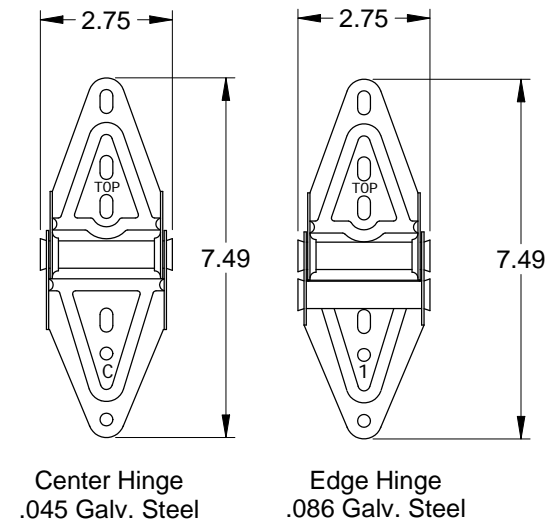
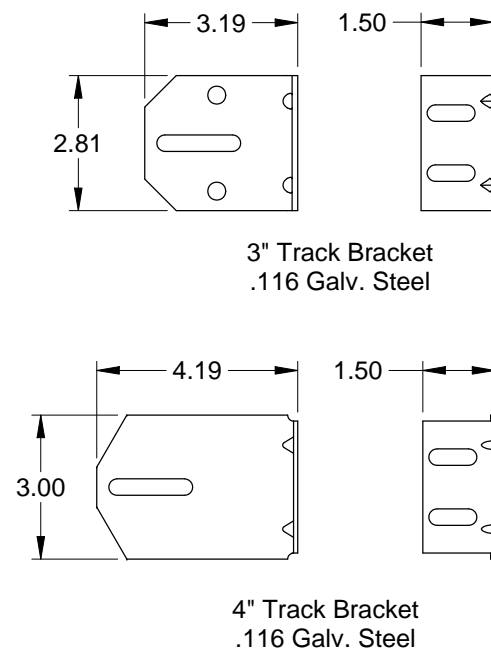
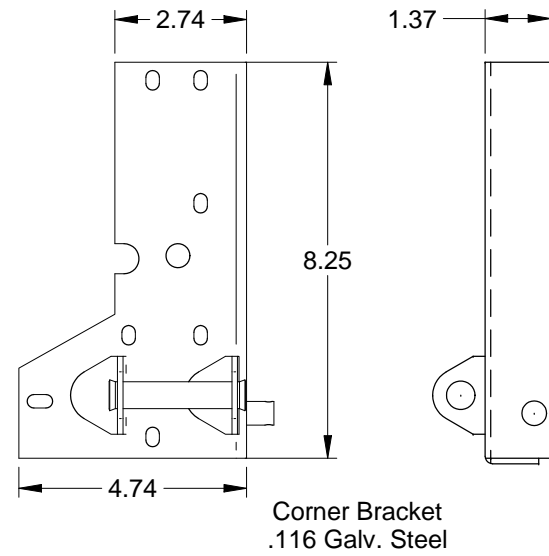

John E. Scates
2560 King Arthur Blvd, Ste 124-54
Lewisville, TX 75056
FL PE #51737
TX PE #56308-f2203

Scale: None
Drawn by: R. Frey
Checked by: G. Wedekind
Date: 02/07/19
ECO: 7679.01



Title: Spec, Wind Load Aspen Series		
No. P-2900	Sheet 3	Rev B