

Top Fixture Attachment

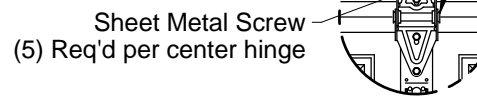

Center Hinge Attachment

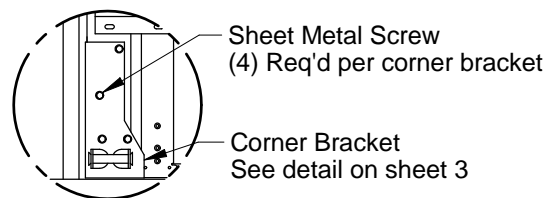

Corner Bracket Attachment

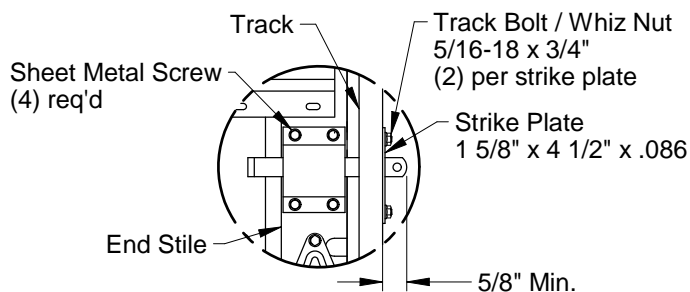

Optional Interior Lock Attachment

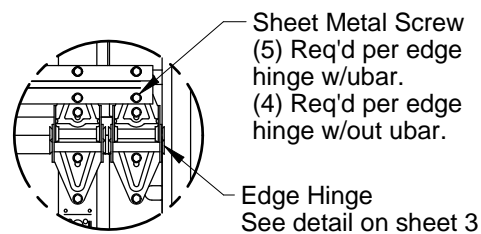

Edge Hinge Attachment

Steel Section
BuildMark .017 thick G-40 galvanized steel
TradeMark .023 thick G-40 galvanized steel with an epoxy primer and baked on polyester finish which is roll-formed with wood grain texture.

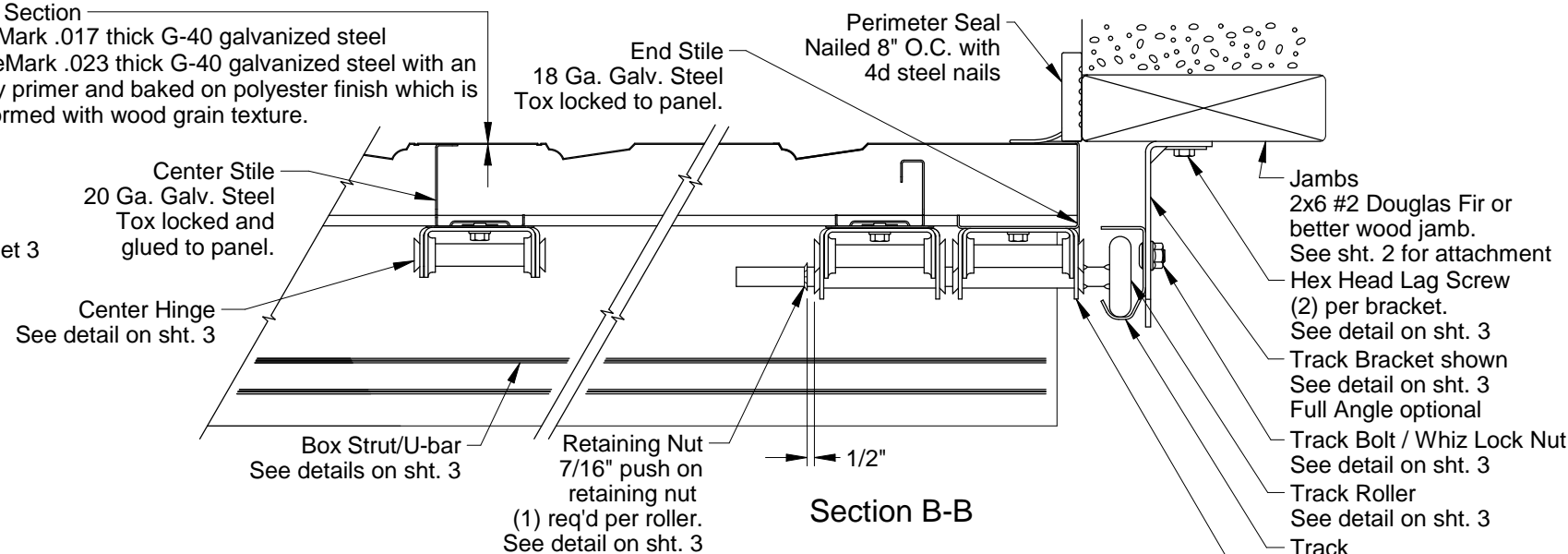

Section B-B

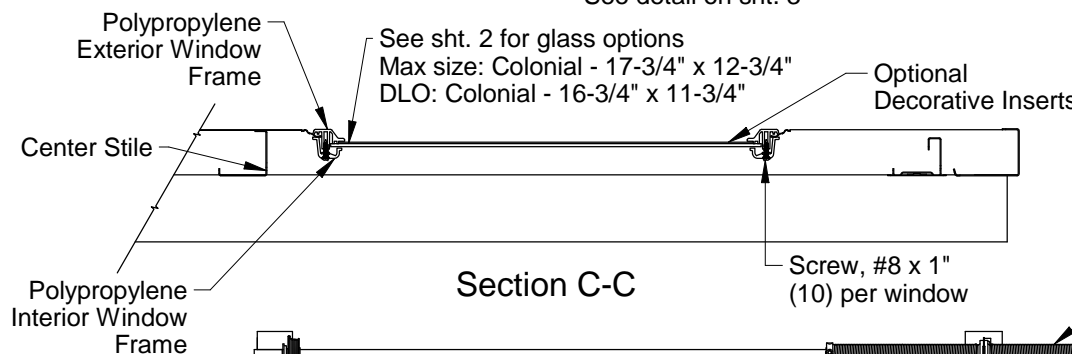

Section C-C

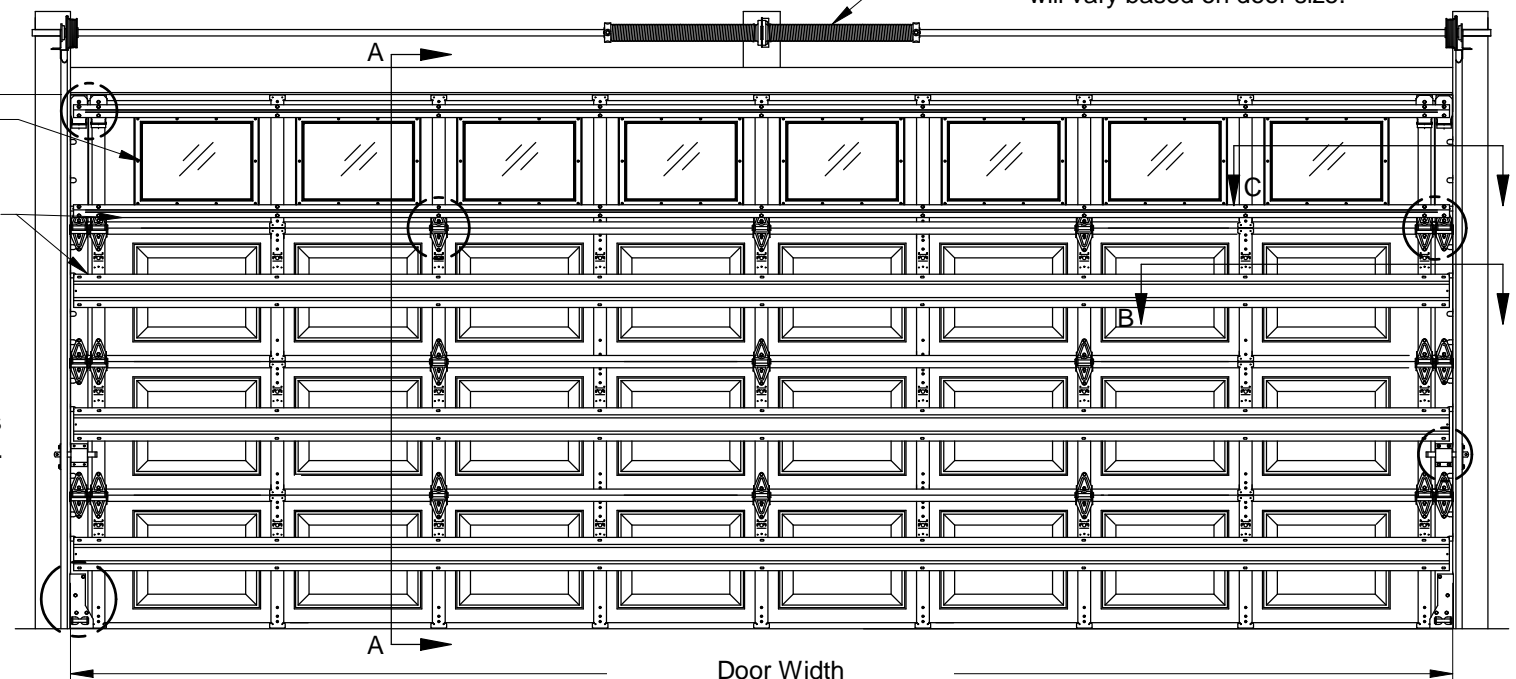

Interior Elevation
Door Width
See chart for other door widths (18'-0" shown)

Windows (Optional)
See options on sht. 2
One row maximum

Steel Reinforcement
(1) Box strut per section,
(2) U-bar on top section fastened to all center and end stiles using (2) sheet metal screws at each stile.

Locks required on doors
not electrically operated.
See details on sht 3.

Door Height
7'- 0" High shown
Other door heights available up to 16'-0" using 18" or 21" high sections

Doors tested per ANSI/DASMA 108 for static air pressure

Maximum Door Width	Colonial				Ranch				Carriage House			
	Stiles per Sect.	Hinges per Sect.	Design Loads		Stiles per Sect.	Hinges per Sect.	Design Loads		Stiles per Sect.	Hinges per Sect.	Design Loads	
8'-0"	3	1			3	1			3	1		
9'-0"	3	1			3	1			3	1		
10'-0"	4	2	33.9	-37.8	3	1	33.9	-37.8	3	1	33.9	-37.8
12'-0"	5	3			5	2			5	2		
14'-0"	6	4			5	2			5	2		
16'-0"	7	3	29.7	-33.1	7	3	29.7	-33.1	7	3	29.7	-33.1
18'-0"	7	3	26.4	-29.4	7	3	26.4	-29.4	7	3	26.4	-29.4

John E. Scates
2560 King Arthur Blvd, Ste 124-54
Lewisville, TX 75056
FL PE #51737
TX PE #56308-f2203

Rev.	Description	ECO	Date
B	Removed vent option on sheet 1.	7679.02	12/09/19
A	New release for production.	7679.01	01/08/19

Scale: None
Drawn by: R. Frey
Checked by: G. Wedekind
Date: 01/08/19
ECO: 7679.01



1101 East River Road
Dixon, IL. 61021

Title: Spec, Wind Load BuildMark / TradeMark	
No. P-2805	Sheet 1 of 3
Rev B	

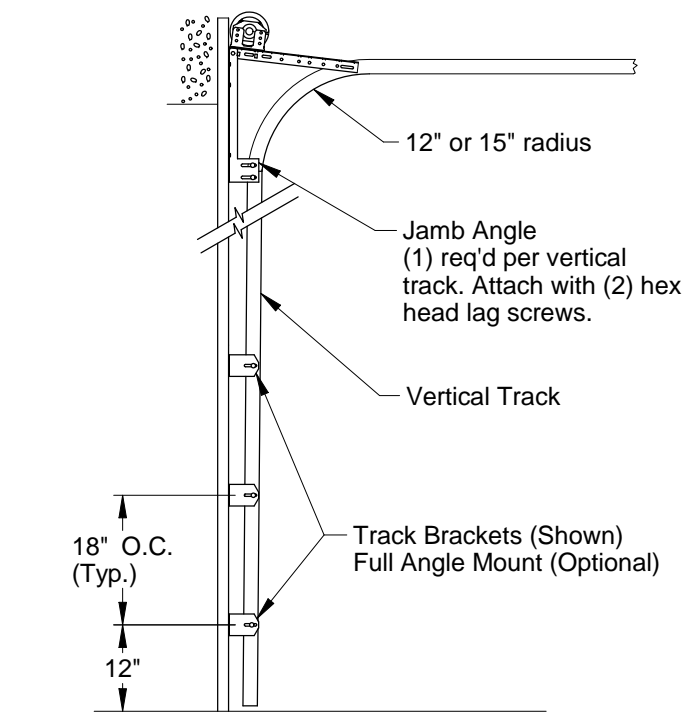

Typical Track Installation
 Normal headroom track shown, low headroom, lift clearance and vertical lift track available

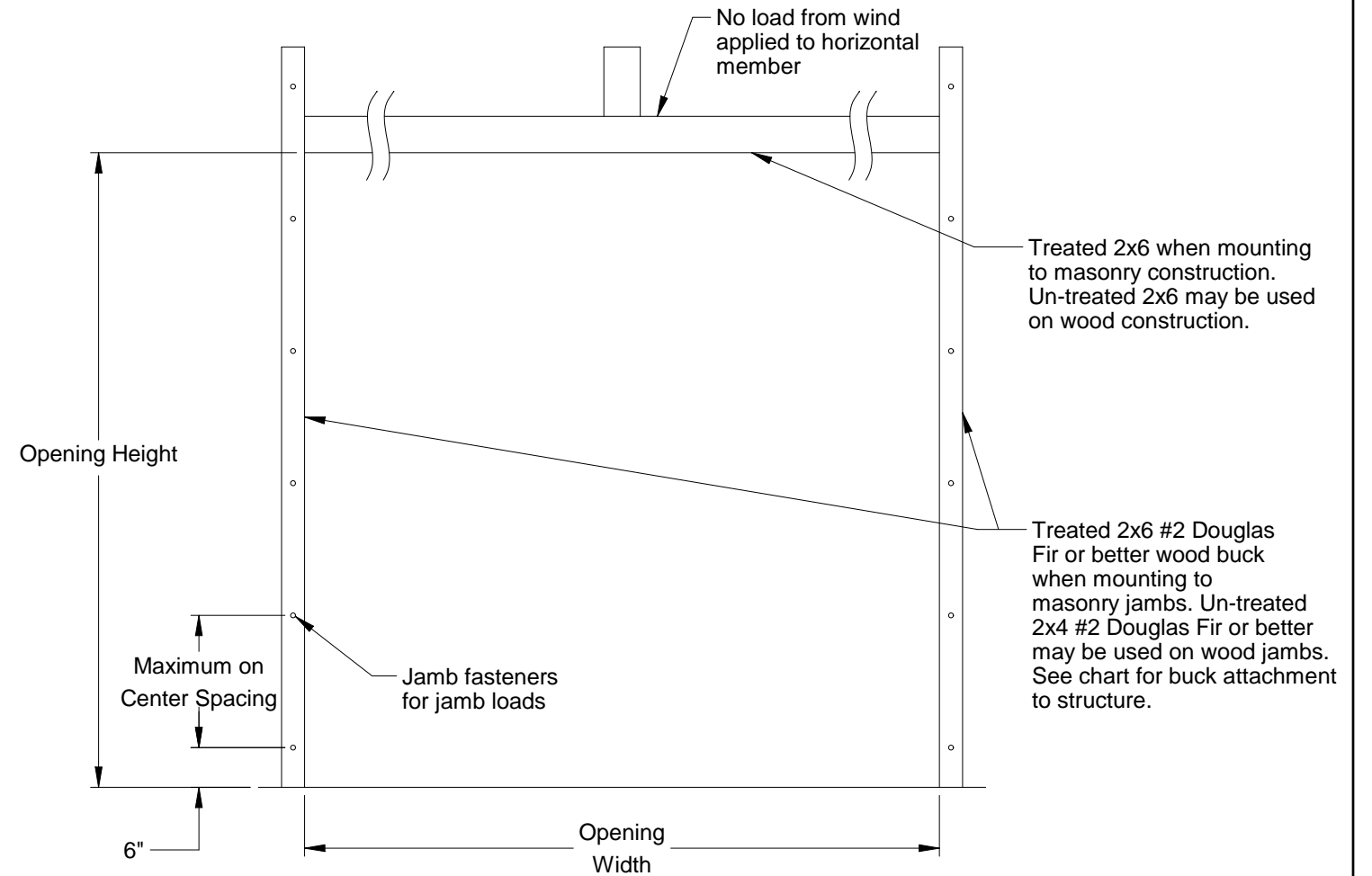

Jamb Attachment Notes:

1. Maximum Positive Load per Jamb = $(18'-0" \times 26.4 \text{ PSF}) / 2 = 238 \text{ lbs. per foot.}$
2. Maximum Negative Load per Jamb = $(18'-0" \times -29.4 \text{ PSF}) / 2 = 265 \text{ lbs. per foot.}$
3. Design of the supporting structure shall be the sole responsibility of the building designer and shall be designed for the jamb loads listed in notes 1 and 2.
4. Alternate jamb attachments may be used if approved by a registered Professional Engineer.
5. DASMA Technical Data Sheet TDS-161 may be used for alternate jamb attachments.
6. 3/8" diameter lag screws required 1/16" pilot hole and 1-1/2" minimum required distance.

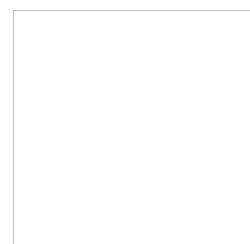

John E. Scates
 2560 King Arthur Blvd, Ste 124-54
 Lewisville, TX 75056
 FL PE #51737
 TX PE #56308-f2203

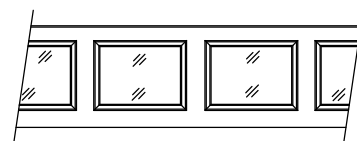

Window Options

Colonial windows
 1/8" DSB - Clear, Obscure, Satin
 1/8" Tempered - Clear, Obscure, Satin

2x6 Attachment to Structure

Structure Type	Fastener Type	Minimum Embedment	Minimum Edge Distance	Minimum on Center Spacing	Maximum on Center Spacing	Allowable Tension Load
2500 PSI Min. Concrete	1/4" Tapcon+ (Plus) with 1-1/8" OD Washer	2"	2.5	6"	24"	526
Southern Pine	3/8" x 3" Lag with 1-1/8" OD Washer	1.50"	1.50"	1.50"	24"	655
Spruce Pine Fir	3/8" x 3" LAG with 1-1/8" OD Washer	1.50"	1.50"	1.50"	24"	482

Scale: None
Drawn by: R. Frey
Checked by: G. Wedekind
Date: 01/08/19
ECO: 7679.01



1101 East River Road
 Dixon, IL 61021

Title: Spec, Wind Load
 BuildMark / TradeMark

No. P-2805

Sheet 2

Rev B

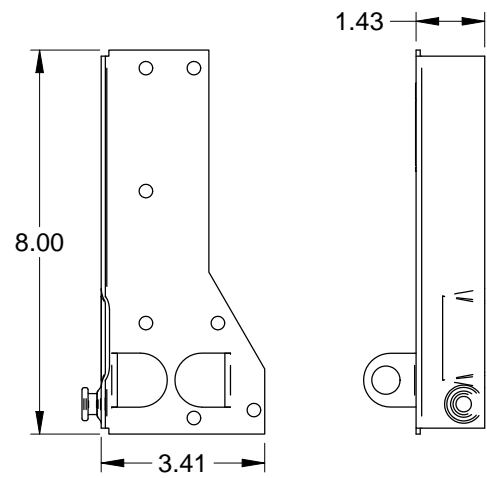

Corner Bracket
.086 Galv. Steel

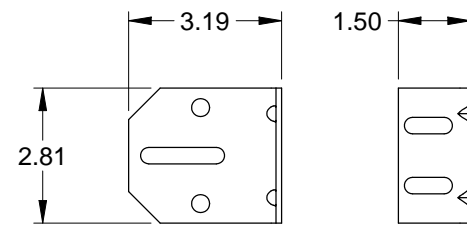

3" Track Bracket
.116 Galv. Steel

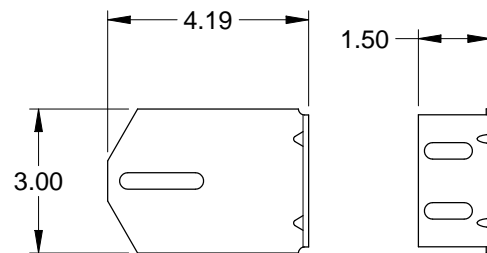

4" Track Bracket
.116 Galv. Steel

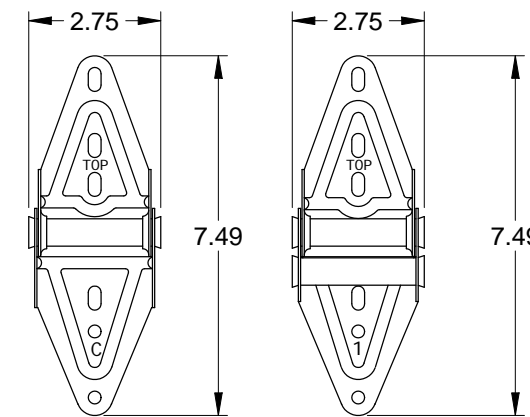

Center Hinge
.045 Galv. Steel

Edge Hinge
.086 Galv. Steel



2" Track
.055 Galv. Steel

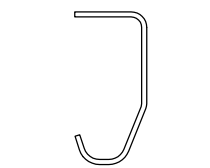

3" Track (Optional)
.105 Galv. Steel

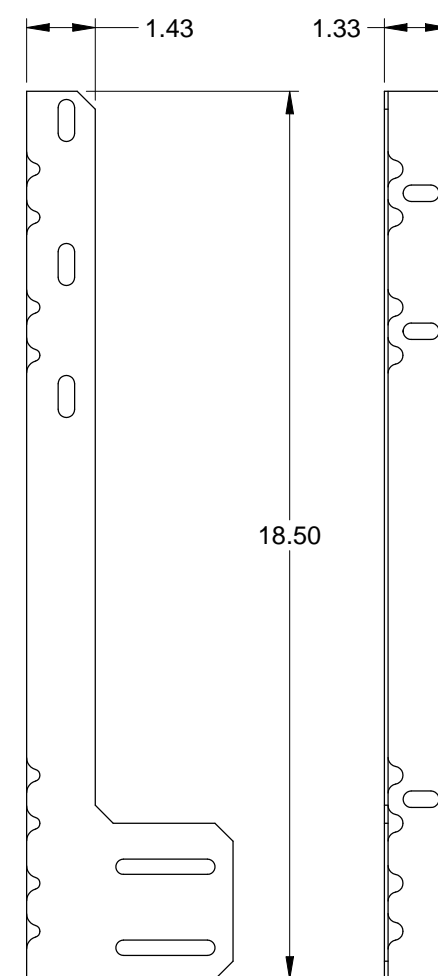

Jamb Angle
.078 Galv. Steel



Steel Box Strut
20 Ga. (.035" min.) Galvanized
High Tensile Steel
80 KSI Minimum Yield

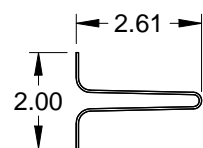

Steel U-Bar
18 Ga. (.049" min.) Galvanized
High Tensile Steel
80 KSI Minimum Yield

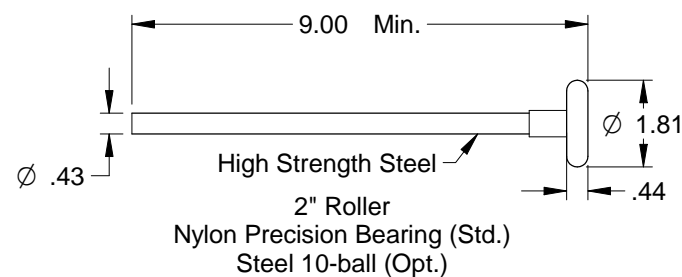

2" Roller
Nylon Precision Bearing (Std.)
Steel 10-ball (Opt.)

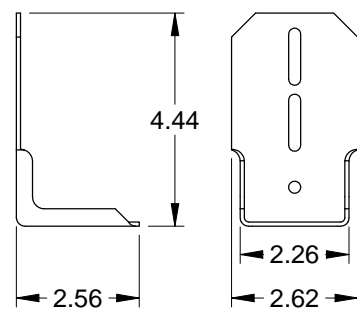

Top Fixture
.086 Galv. Steel

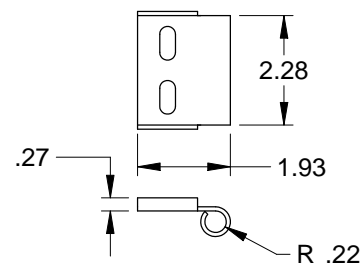

Roller Carrier
.116 Galv. Steel
Attached to Top Fixture
w/(2) Track Bolts and Whiz Nuts

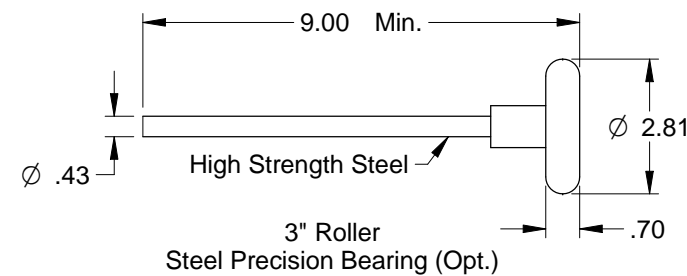

3" Roller
Steel Precision Bearing (Opt.)

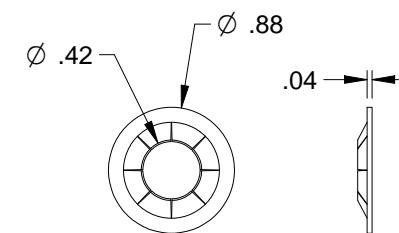

Retaining Nut

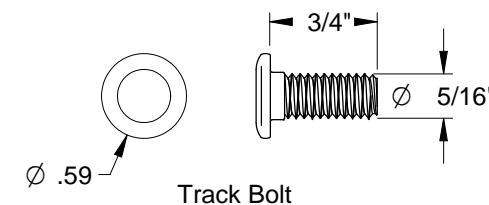

Track Bolt

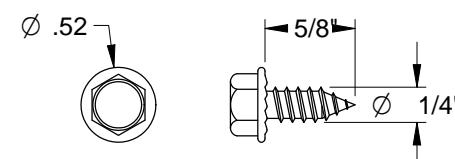

Sheet Metal Screw

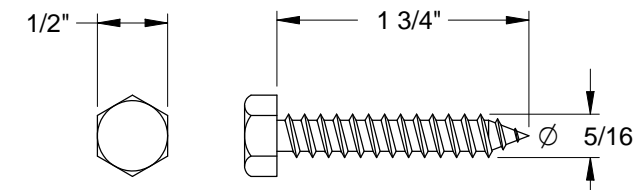

Hex Head Lag Screw

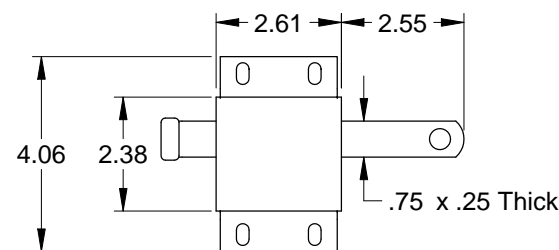

Slide Lock
Case .086 Galv. Steel

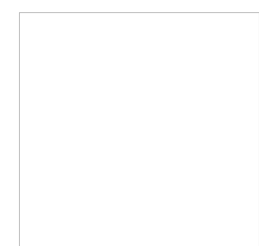

John E. Scates
2560 King Arthur Blvd, Ste 124-54
Lewisville, TX 75056
FL PE #51737
TX PE #56308-f2203

Scale: None	<p>1101 East River Road Dixon, IL 61021</p>	Title: Spec, Wind Load BuildMark / TradeMark	
Drawn by: R. Frey		No. P-2805	Sheet 3
Checked by: G. Wedekind			Rev B
Date: 01/08/19			
ECO: 7679.01			