

Doors tested per ANSI/DASMA 108 for static air pressure

Maximum Door Width	Colonial				Ranch				Carriage House			
	Stiles per Sect.	Hinges per Sect.	Design Loads		Stiles per Sect.	Hinges per Sect.	Design Loads		Stiles per Sect.	Hinges per Sect.	Design Loads	
8'-0"	1	1	31.1	-37.3	1	1	31.1	-37.3	1	1	31.1	-37.3
9'-0"	1	1			1	1			1	1		
10'-0"	2	2			1	1			1	1		
12'-0"	3	3	26.6	-32.0	2	2	26.6	-32.0	2	2	26.6	-32.0
14'-0"	4	4			2	2			2	2		
16'-0"	3	3			23.3	-28.0			3	3		

John E. Scates
 2560 King Arthur Blvd, Ste 124-54
 Lewisville, TX 75056
 FL PE #51737
 TX PE #56308-f2203

Scale: None	Title: Spec, Wind Load BuildMark / TradeMark	
Drawn by: R. Frey	Checked by: G. Wedekind	
Date: 01/07/19	ECO: 7679.01	
Rev. B	Description: Removed vent option on sheet 1.	7679.02 12/09/19
Rev. A	Description: New release for production.	7679.01 01/07/19
Rev.	Description:	ECO Date

1101 East River Road
Dixon, IL 61021

No. P-2806	Sheet 1 of 3	Rev B
------------	--------------	-------

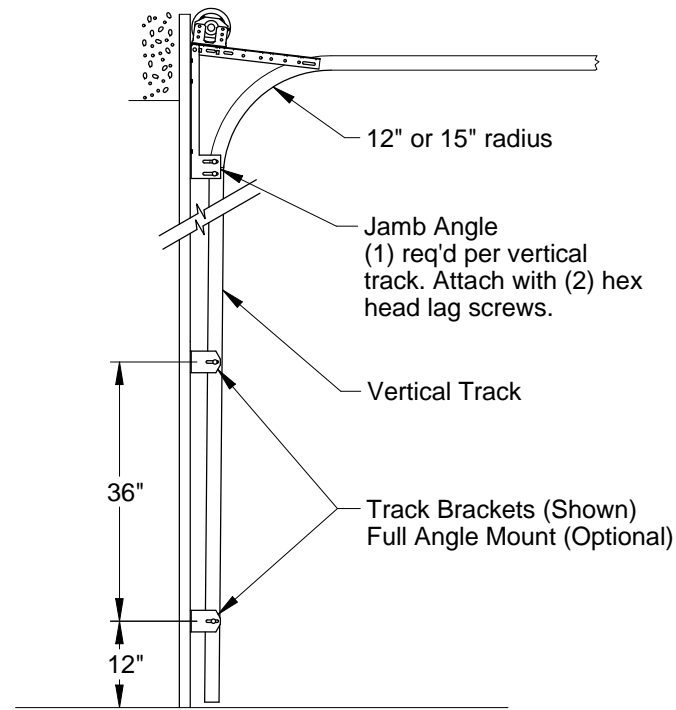

Typical Track Installation
Normal headroom track shown, low headroom, lift clearance and vertical lift track available

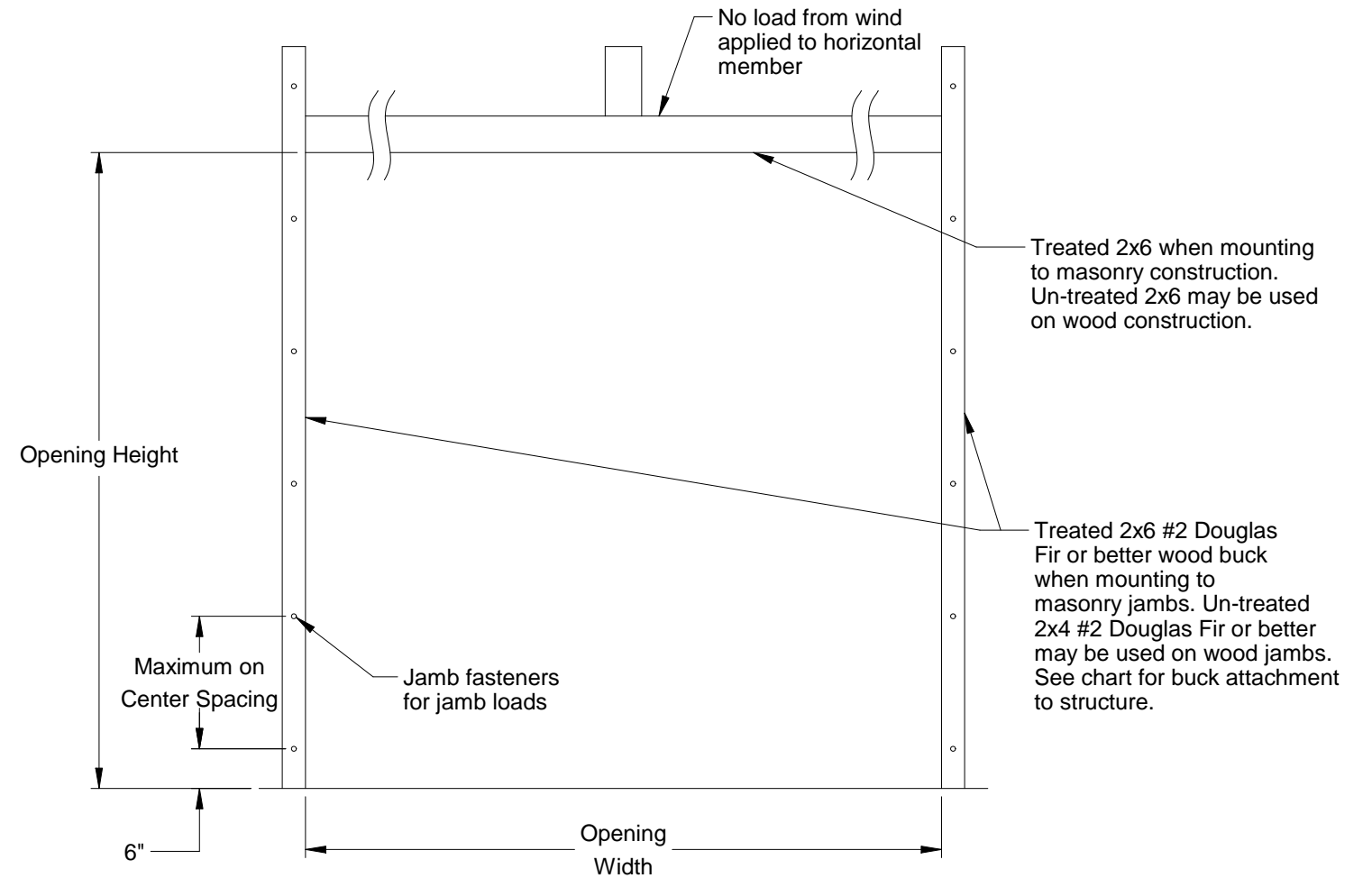

Jamb Attachment Notes:

1. Maximum Positive Load per Jamb = (16'-0" x 23.3 PSF) / 2 = 187 lbs. per foot.
2. Maximum Negative Load per Jamb = (16'-0" x -28.0 PSF) / 2 = 224 lbs. per foot.
3. Design of the supporting structure shall be the sole responsibility of the building designer and shall be designed for the jamb loads listed in notes 1 and 2.
4. Alternate jamb attachments may be used if approved by a registered Professional Engineer.
5. DASMA Technical Data Sheet TDS-161 may be used for alternate jamb attachments.
6. 3/8" diameter lag screws required 1/16" pilot hole and 1-1/2" minimum required distance.

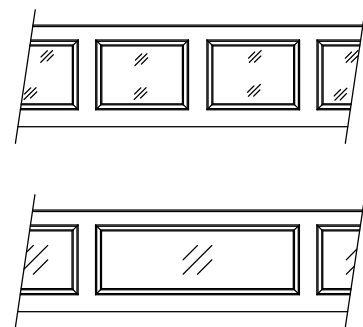

Colonial windows
1/8" DSB - Clear, Obscure, Satin
1/8" Tempered - Clear, Obscure, Satin

Ranch windows
1/8" DSB - Clear, Obscure, Satin
1/8" Tempered - Clear, Obscure, Satin

Window Options

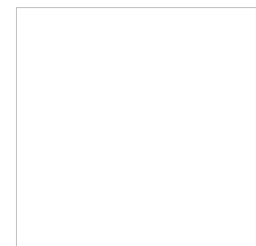

John E. Scates
2560 King Arthur Blvd, Ste 124-54
Lewisville, TX 75056
FL PE #51737
TX PE #56308-f2203

2x6 Attachment to Structure						
Structure Type	Fastener Type	Minimum Embedment	Minimum Edge Distance	Minimum on Center Spacing	Maximum on Center Spacing	Allowable Tension Load
2500 PSI Min. Concrete	1/4" Tapcon+ (Plus) with 1-1/8" OD Washer	2"	2.5	6"	24"	526
Southern Pine	3/8" x 3" Lag with 1-1/8" OD Washer	1.50"	1.50"	1.50"	24"	655
Spruce Pine Fir	3/8" x 3" LAG with 1-1/8" OD Washer	1.50"	1.50"	1.50"	24"	482

Scale: None
Drawn by: R. Frey
Checked by: G. Wedekind
Date: 01/07/19
ECO: 7679.01



1101 East River Road
Dixon, IL. 61021

Title: Spec, Wind Load
BuildMark / TradeMark

No. P-2806

Sheet 2

Rev B

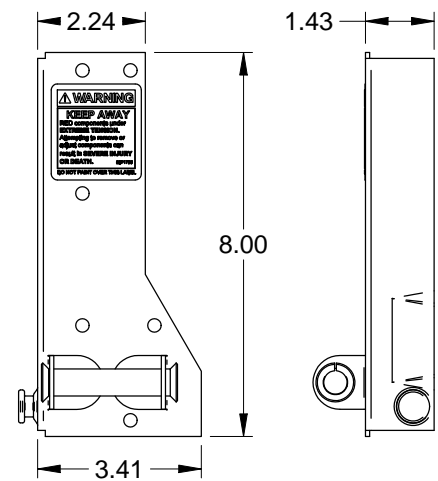

Corner Bracket
.086 Galv. Steel

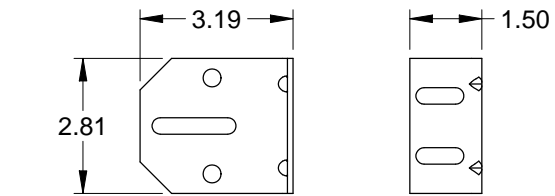

3" Track Bracket
.116 Galv. Steel

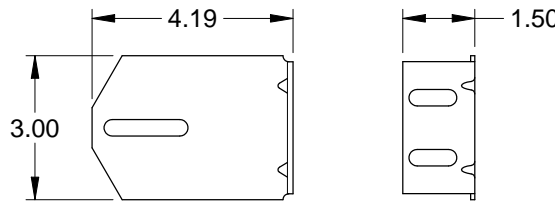

4" Track Bracket
.116 Galv. Steel

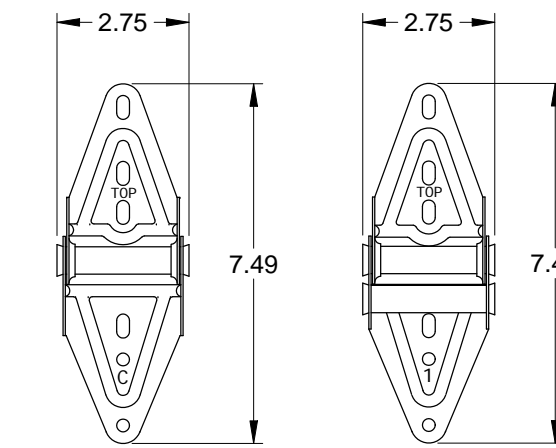

Center Hinge
.070 Galv. Steel

Edge Hinge
.086 Galv. Steel

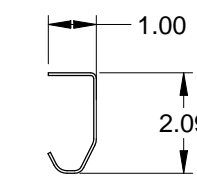

2" Track
.055 Galv. Steel

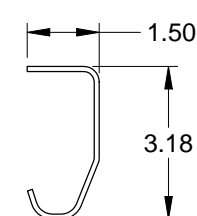

3" Track (Optional)
.105 Galv. Steel

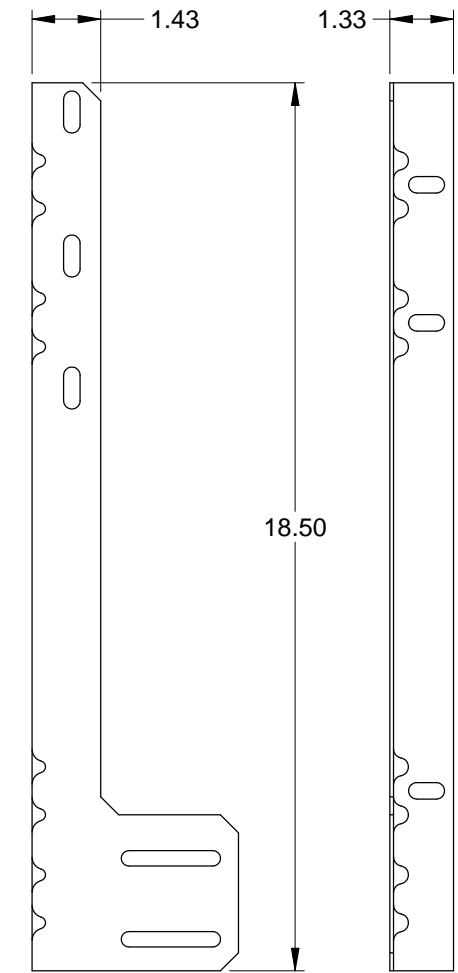

Jamb Angle
.078 Galv. Steel

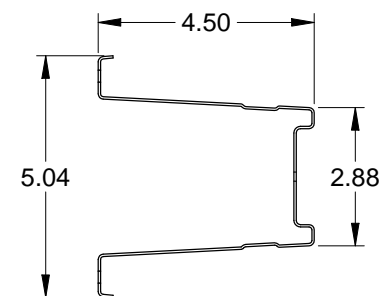

Steel Box Strut
20 Ga. (.035" Min.) Galvanized
High Tensile Steel
80 KSI Minimum Yield

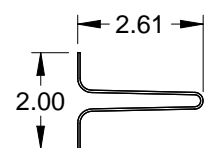

Steel U-bar
18 Ga. (.049" Min.) Galvanized
High Tensile Steel
80 KSI Minimum Yield

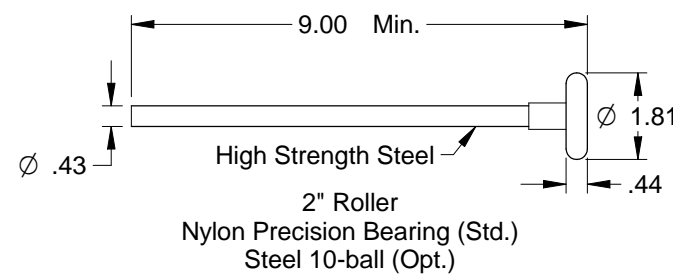

2" Roller
Nylon Precision Bearing (Std.)
Steel 10-ball (Opt.)

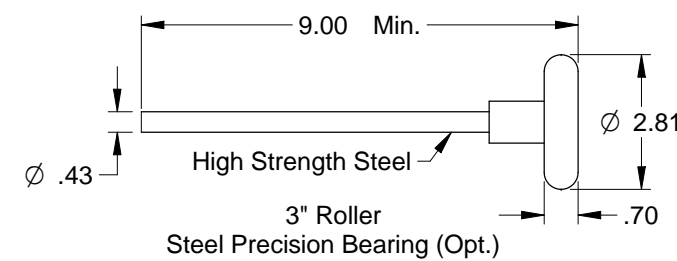

3" Roller
Steel Precision Bearing (Opt.)

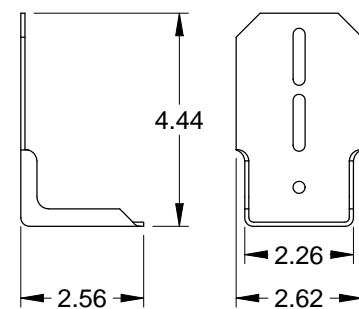

Top Fixture
.086 Galv. Steel

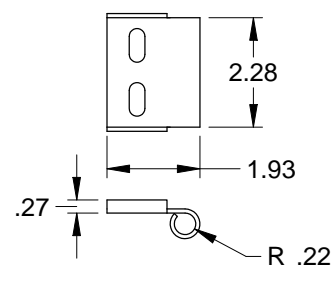

Roller Carrier
.086 Galv. Steel
Attached to Top Fixture
w/(2) Track Bolts and Whiz Nuts

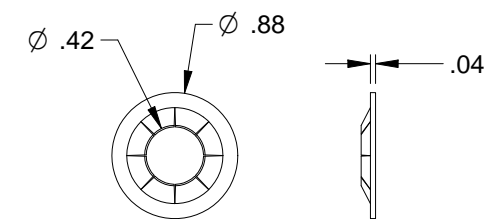

Retaining Nut

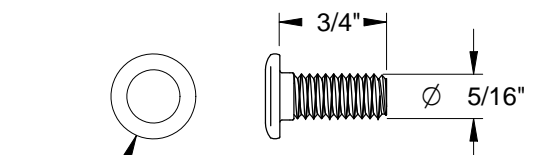

Track Bolt

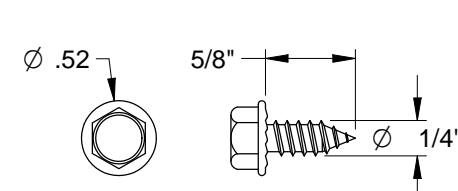

Sheet Metal Screw

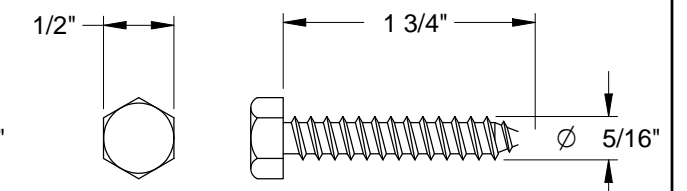

Hex Head Lag Screw

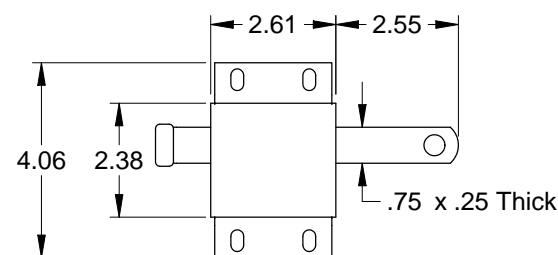

Slide Lock
Case .086 Galv. Steel

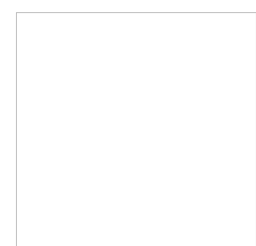

John E. Scates
2560 King Arthur Blvd, Ste 124-54
Lewisville, TX 75056
FL PE #51737
TX PE #56308-f2203

Scale: None
Drawn by: R. Frey
Checked by: G. Wedekind
Date: 01/07/19
ECO: 7679.01



1101 East River Road
Dixon, IL 61021

Title: Spec, Wind Load BuildMark / TradeMark		
No. P-2806	Sheet 3	Rev B