

NOTES

- NON-IMPACT RESISTANT OPTION - 125" MINIMUM DSB GLAZING MEETS UNIFORM STATIC DESIGN PRESSURES SHOWN ON THIS DRAWING. GLAZING SHALL HAVE A MAXIMUM HEIGHT OF 6.70" AND A MAXIMUM LENGTH OF 24.00". GLAZING IS NOT IMPACT RESISTANT AND DOES NOT MEET THE REQUIREMENTS FOR WIND-BORNE DEBRIS REGIONS.
- IMPACT RESISTANT GLAZING OPTION - IMPACT RESISTANT GLAZING SYSTEM MAY BE INSTALLED IN INTERMEDIATE SECTIONS (WITH OR WITHOUT DECORATIVE INSERTS). GLAZING SHALL BE 1/4" POLYCARBONATE. MAXIMUM GLAZING DIMENSIONS SHALL BE 11" x 17", FASTENED WITH A MINIMUM #8 X 1" SMS: 3X ALONG THE HORIZONTAL AND 2X ALONG THE VERTICAL.
- ALUMINUM FULL VIEW OPTION - ALUMINUM FULL VIEW SECTION MAY REPLACE ANY SECTION EXCEPT TOP AND BOTTOM PANELS. ALUMINUM FULL VIEW SECTION SHALL HAVE RAILS AND STILES OF EXTRUDED ALUMINUM ALLOY 6063-T6 AND 125" MINIMUM DSB GLAZING INSTALLED WITH ALUMINUM RETAINERS IN ORDER TO MEET UNIFORM STATIC DESIGN PRESSURES SHOWN ON THIS DRAWING. AFV PANEL SIZE IS 45.5"x21.9" (MAX). GLAZING IS NOT IMPACT RESISTANT AND DOES NOT MEET THE REQUIREMENTS FOR WIND-BORNE DEBRIS REGIONS.
- MINIMUM OF 1" OVERLAP ON BOTH JAMBS REQUIRED TO MEET NEGATIVE DESIGN PRESSURES.
- SLIDE LOCK OR OPERATOR REQUIRED.
- SECTION STEEL TO HAVE THE FOLLOWING MINIMUM THICKNESS:  
421, 423 - 20 GA  
427, 429 - 24 GA  
434, 436 - 25 GA
- THE DESIGN OF THE SUPPORTING STRUCTURAL ELEMENTS SHALL BE THE RESPONSIBILITY OF THE PROFESSIONAL OF RECORD FOR THE BUILDING OR STRUCTURE AND IN ACCORDANCE WITH CURRENT BUILDING CODES FOR THE LOADS LISTED ON THIS DRAWING.
- TRACK CLIPS SHALL BE LOCATED WITH CENTERLINE OF BOTTOM CLIP SPACED 10" MAX FROM BOTTOM OF TRACK AND REMAINING TRACK CLIPS SPACED AT 24" O.C. MAX. SPACING BETWEEN TOP TRACK CLIP AND SPLICE PLATE SHALL BE 30" O.C. MAX.
- WHEN MOUNTING TO WOOD, DOOR JAMB TO BE MINIMUM 2x6 STRUCTURAL GRADE LUMBER. REFER TO JAMB CONNECTION SUPPLEMENT FOR ATTACHMENT TO SUPPORTING STRUCTURE.

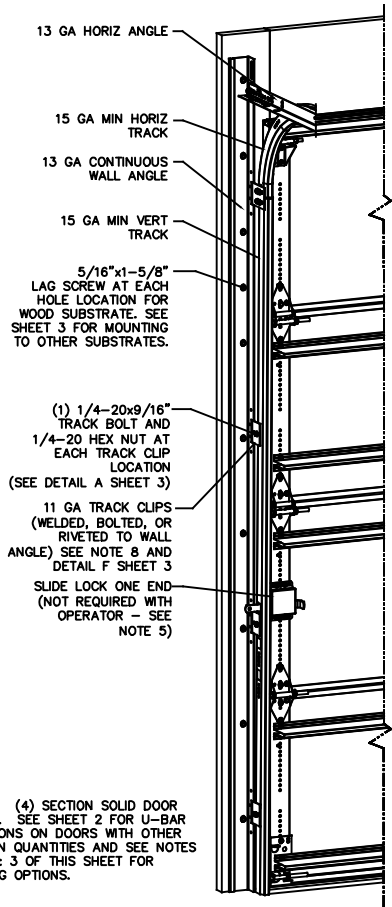

NOTE: (4) SECTION SOLID DOOR SHOWN. SEE SHEET 2 FOR U-BAR LOCATIONS ON DOORS WITH OTHER SECTION QUANTITIES AND SEE NOTES 1, 2, & 3 OF THIS SHEET FOR GLAZING OPTIONS.

SUPERIMPOSED DESIGN PRESSURE LOADS ON SUPPORTING STRUCTURE		
MAX DOOR WIDTH	DOOR HEIGHT	MAX UNIFORM LOAD EACH JAMB (PLF)
9'-4"	ALL	+174.4/-197.6

REVISIONS				
OR	REV	DESCRIPTION	DATE	APPROVAL
VL005	-	INITIAL DRAWING	1/13/2021	TLC
VL005	A	ADDED AFV PANEL SIZE	4/27/21	TLC

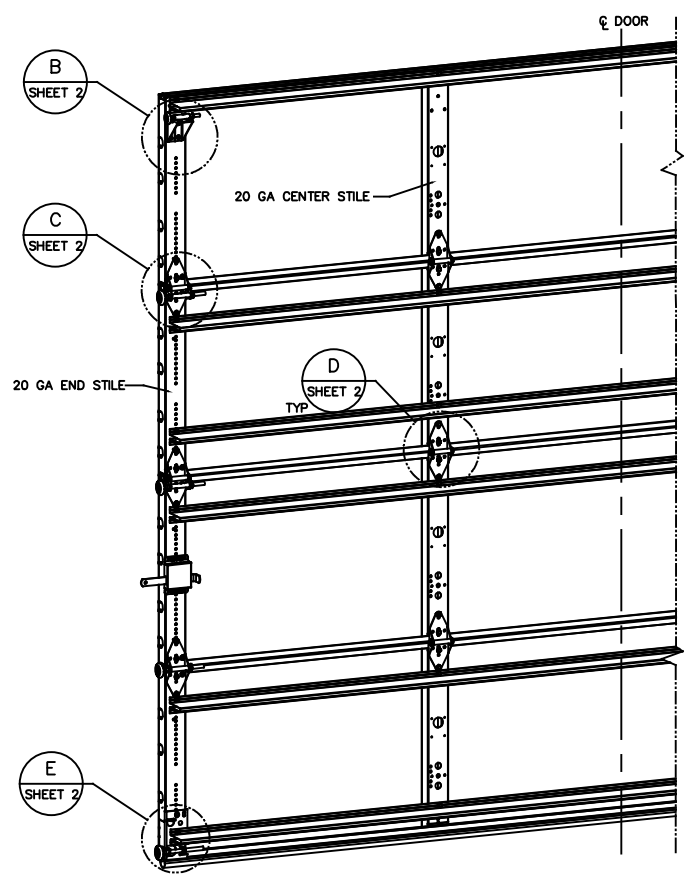

THE DOORS ARE DESIGNED AND MANUFACTURED TO COMPLY WITH THE 2018 IRC AND THE 2018 IBC.

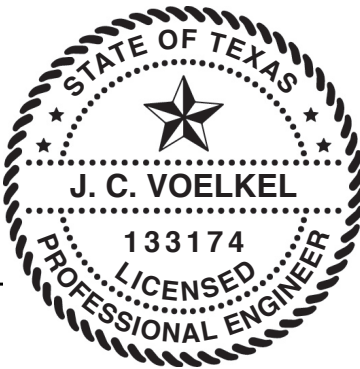

STATIC PRESSURE RATINGS		APPROVED SIZES	
DESIGN PRESSURE (PSF):	+37.5/-42.5	MAX WIDTH:	9'-4"
		MAX HEIGHT:	24'-1"
IMPACT/CYCLIC RATED:	YES	MAX SECTION HEIGHT:	24'

THE DRAWING AND ALL OTHER INFORMATION CONTAINED HEREIN ARE THE CONFIDENTIAL AND PROPRIETARY PROPERTY OF OVERHEAD DOOR CORPORATION AND ITS AFFILIATED COMPANIES. THIS DRAWING AND INFORMATION, IN WHOLE OR IN PART, MAY NOT BE COPIED IN ANY MANNER OR DISCLOSED TO ANYONE WITHOUT THE PRIOR WRITTEN CONSENT OF OVERHEAD DOOR CORPORATION. NO DISCLOSURE OF ANY OF THIS DRAWING OR INFORMATION IS INTENDED TO OPERATE AS A LICENSE OR AUTHORIZATION TO USE IT FOR ANY PURPOSE WITHOUT THE SPECIFIC WRITTEN CONSENT OF OVERHEAD DOOR CORPORATION.			
	HOLE DIAMETER UNDER .251 +.004/-003 .251 TO .500 +.006/-003 OVER .500 +.008/-003	WHOLE NUMBERS: ± .25 .X ± .1 .XX ± .03 .XXX ± .010 ANGLES: ± .5°	FINISH: N/A UNIT OF MEASURE: EA
	REF DWG: USED ON:	FRACTIONS: ± 1/16	MATERIAL: N/A
DRAWING TITLE: WINDLOAD OPTION CODE 2065 SERIES 421/423/427/429/434/436, 37.5/-42.5 PSF, 9'-4" MAX			DRAWING NUMBER: D-411781 SCALE: N/A SHEET 1 OF 3

1/4-20x9/16" TRACK BOLT AND 1/4-20 HEX NUT THROUGH THE SLOT IN THE TRACK AND TRACK CLIP

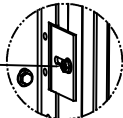

DETAIL A

12 GA COMMERCIAL TOP FRAME BRACKET WITH 13 GA ROLLER CARRIER ATTACHED WITH (4) 1/4-14x7/8" SELF DRILLING CRIMPITITE SCREWS

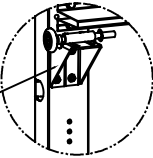

DETAIL B

ADD (2) 1/4-14x7/8" SELF DRILLING CRIMPITITE SCREWS (INSIDE OF EACH INSIDE END HINGE)

2" STEEL ROLLER WITH 5-1/8" STEM AND 7/16" PUSHNUT AT EACH ROLLER LOCATION. 1/4" MAX BETWEEN PUSHNUT AND BRACKET OR HINGE

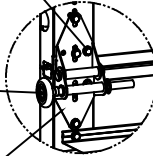

DETAIL C

14 GA WIDE BODY END HINGE TO ATTACH SECTIONS ONE AND TWO. 13 GA WIDE BODY END HINGE TO ATTACH REMAINING SECTIONS. FOR ALL, ATTACH WITH (4) 1/4-14x7/8" SELF DRILLING CRIMPITITE SCREWS

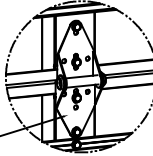

SOLID SECTION

14 GA WIDE BODY INTERMEDIATE HINGE ATTACHED WITH (4) 1/4-14x7/8" SELF DRILLING CRIMPITITE SCREWS

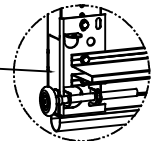

DETAIL E

12 GA BOTTOM BRACKET ATTACHED WITH (3) 1/4-14x7/8" SELF DRILLING CRIMPITITE SCREWS

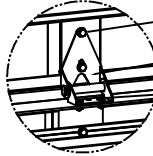

AFV SECTION

(2) 1/4-14x7/8" SELF DRILLING CRIMPITITE SCREWS  
HALF HINGE  
(2) 1/4 x 1/2" CARRIAGE BOLTS AND 1/4" FLANGE NUTS

DETAIL D

ATTACH U-BARS WITH (2) 1/4-14x7/8" SELF DRILLING CRIMPITITE SCREWS AT ALL STILE LOCATIONS, TYP.

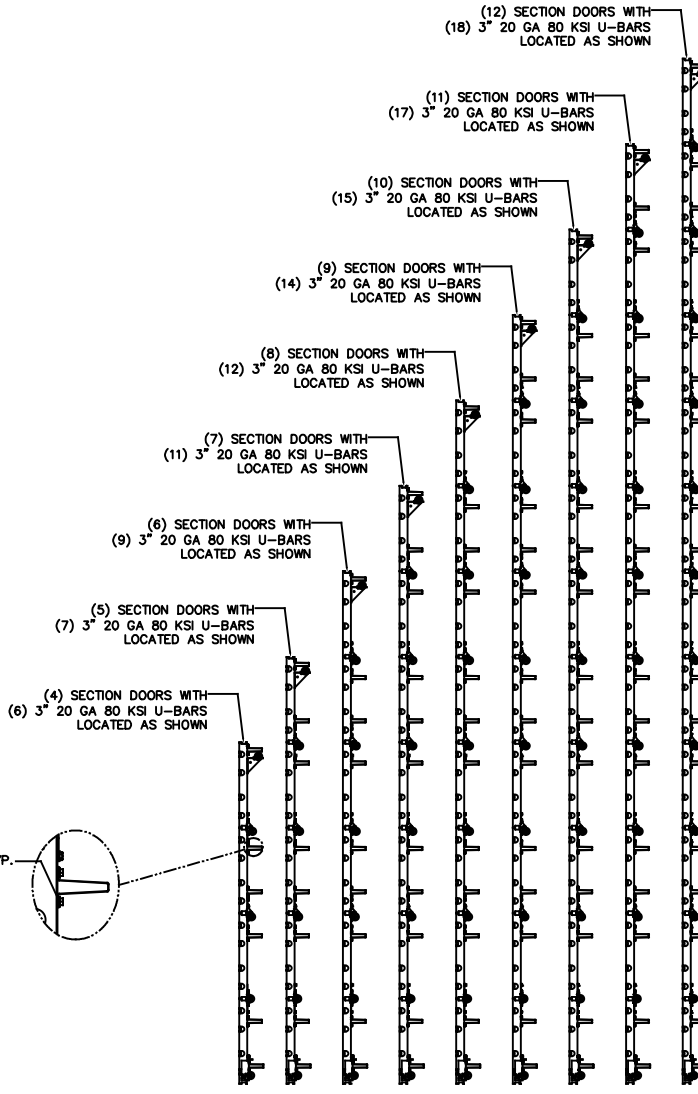

STATIC PRESSURE RATINGS	APPROVED SIZES
DESIGN PRESSURE(PSF): +37.5/-42.5	MAX WIDTH: 9'-4"
	MAX HEIGHT: 24'-1"
IMPACT/CYCLIC RATED: YES	MAX SECTION HEIGHT: 24'

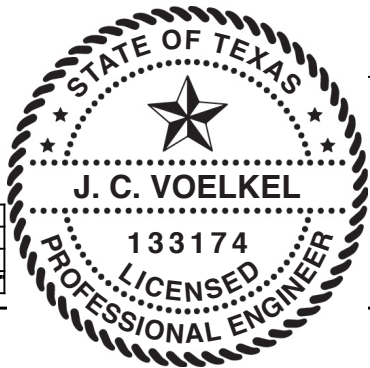

THE DRAWINGS AND ALL OTHER INFORMATION CONTAINED HEREIN ARE THE CONFIDENTIAL AND PROPRIETARY PROPERTY OF OVERHEAD DOOR CORPORATION AND ITS AFFILIATED COMPANIES. THIS DRAWING AND INFORMATION, IN WHOLE OR IN PART, MAY NOT BE COPIED IN ANY MANNER OR DISCLOSED TO ANYONE WITHOUT THE PRIOR WRITTEN CONSENT OF OVERHEAD DOOR CORPORATION. NO DISCLOSURE OF ANY OF THIS DRAWING OR INFORMATION IS INTENDED TO OPERATE AS A LICENSE OR AUTHORIZATION TO USE IT FOR ANY PURPOSE WITHOUT THE SPECIFIC WRITTEN CONSENT OF OVERHEAD DOOR CORPORATION.			
	TITLE: <b>TELESCOPE UNLESS OTHERWISE SPECIFIED</b> UNDER .251 +.004/- .003 .251 TO .500 +.006/- .003 OVER .500 +.008/- .003 FRACTIONS: ± 1/16	WHOLE NUMBERS: ± .25 .X ± .1 .XX ± .03 .XXX ± .010 ANGLES: ± .5°	FINISH: N/A UNIT OF MEASURE: EA
	REF DWG: _____ USED ON: _____		MATERIAL: N/A
DATE: 9/12/2020		DRAWING TITLE: JINDL/DAD/OPTION CODE 2065 SERIES 421/423/427/429/434/436, 37.5/-42.5 PSF, 9'-4" MAX	
CHECKED BY: T CLARK		DATE: 1/21/21	
APPROVED BY: J QIAN		DATE: 4/27/21	
DRAWING NUMBER: D-411781		SHEET 2 OF 3	

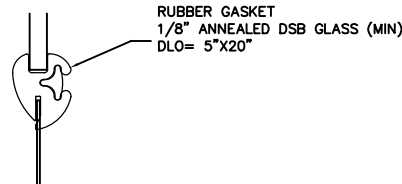
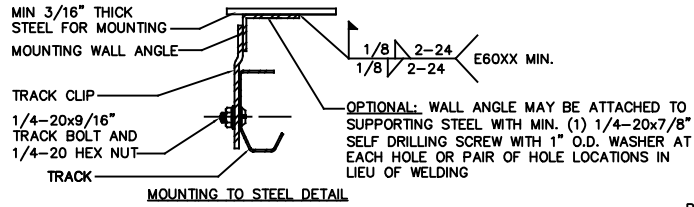

RUBBER FRAME GASKET  
(NON-INSULATED DOORS)

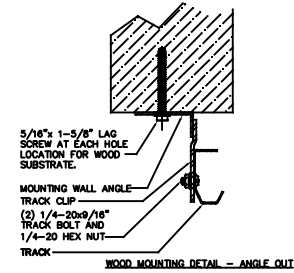

WOOD MOUNTING DETAIL - ANGLE CUT

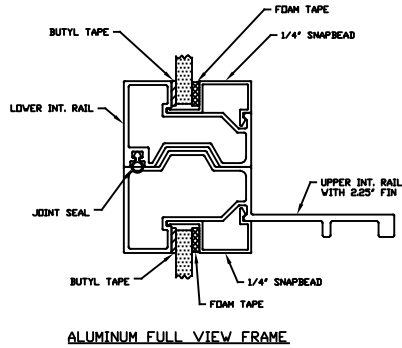

ALUMINUM FULL VIEW FRAME

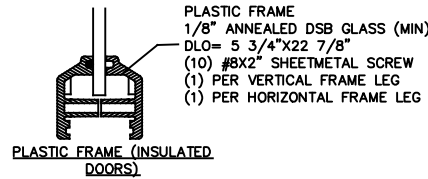

PLASTIC FRAME (INSULATED DOORS)

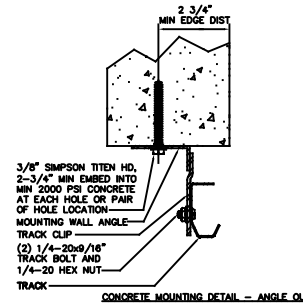

CONCRETE MOUNTING DETAIL - ANGLE CUT

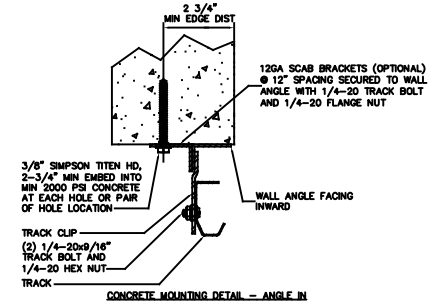

CONCRETE MOUNTING DETAIL - ANGLE IN

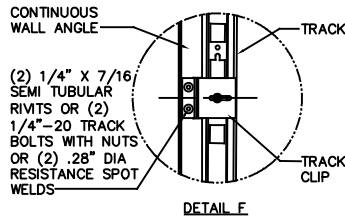

DETAIL F

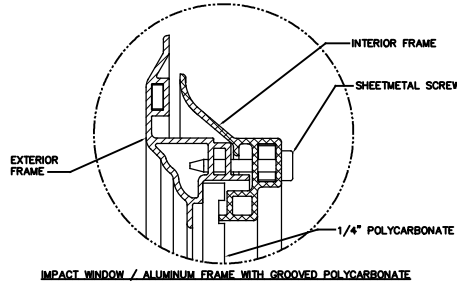

IMPACT WINDOW / ALUMINUM FRAME WITH GROOVED POLYCARBONATE

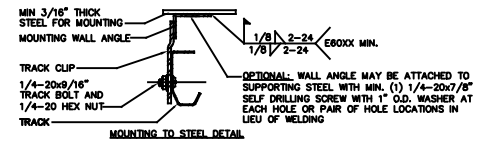

MOUNTING TO STEEL DETAIL

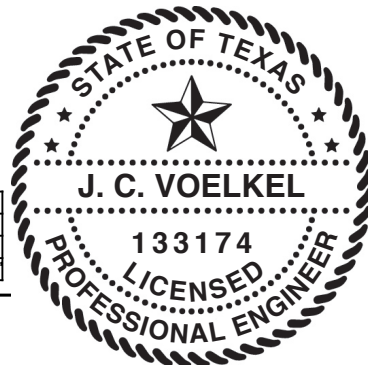

STATIC PRESSURE RATINGS	APPROVED SIZES
DESIGN PRESSURE(PSF): +37.5/-42.5	MAX WIDTH: 9'-4"
	MAX HEIGHT: 24'-1"
IMPACT/CYCLIC RATED: YES	MAX SECTION HEIGHT: 24'

THE DRAWINGS AND ALL OTHER INFORMATION CONTAINED HEREIN ARE THE CONFIDENTIAL AND PROPRIETARY PROPERTY OF OVERHEAD DOOR CORPORATION AND ITS AFFILIATED COMPANIES. THIS DRAWING AND INFORMATION, IN WHOLE OR IN PART, MAY NOT BE COPIED IN ANY MANNER OR DISCLOSED TO ANYONE WITHOUT THE PRIOR WRITTEN CONSENT OF OVERHEAD DOOR CORPORATION. NO DISCLOSURE OF ANY OF THIS DRAWING OR INFORMATION IS INTENDED TO OPERATE AS A LICENSE OR AUTHORIZATION TO USE IT FOR ANY PURPOSE WITHOUT THE SPECIFIC WRITTEN CONSENT OF OVERHEAD DOOR CORPORATION.		FINISH: N/A		DATE: 9/12/2020		DRAWING TITLE: JINDL/DAD/OPTION CODE 2065	
TOLERANCES UNLESS OTHERWISE SPECIFIED		WHOLE NUMBERS: ± .25		DRAWN BY: T. CLARK		SERIES 421/423/427/429/434/436, 37.5/-42.5 PSF, 9'-4" MAX	
HOLE DIAMETER	UNDER .251 +.004/- .003	XXX	± .1	CHECKED BY: J. QIAN		DRAWING NUMBER: D-411781	
	.251 TO .500 +.006/- .003	XXXX	± .03	APPROVED BY: T. CLARK		SCALE: N/A	
	OVER .500 +.008/- .003	XXXXX	± .010			SHEET 3 OF 3	
	FRACTIONS	ANGLES	± .5°				
REF DWG	USED ON	UNIT OF MEASURE	EA				