

L'TR	REVISION	DATE	BY	E.C.O.
*	ORIGINAL ISSUE	09/02/15	TJE	1677
A	REVISED TITLE BLOCK; HOOD SUPPORT UPDATE; 2018 IBC	03/09/20	MAN	2028

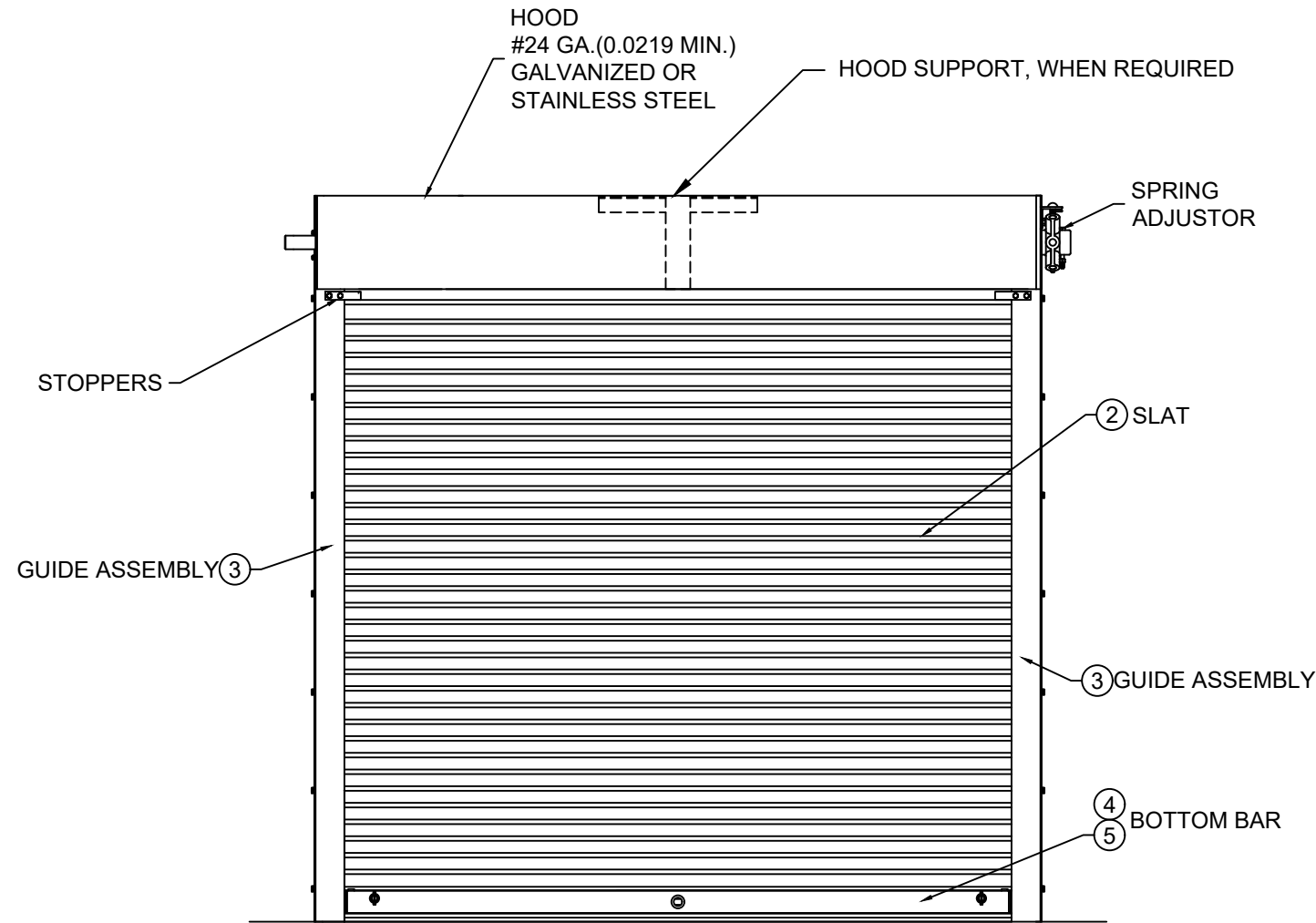

ROLL-UP MECHANISM NOT INCLUDED IN THIS APPROVAL. MUST BE CERTIFIED BY AN INDEPENDENT TESTING AGENCY IF REQUIRED.

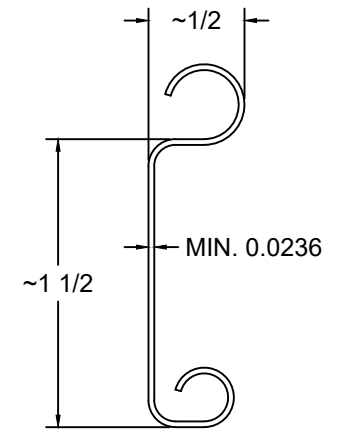
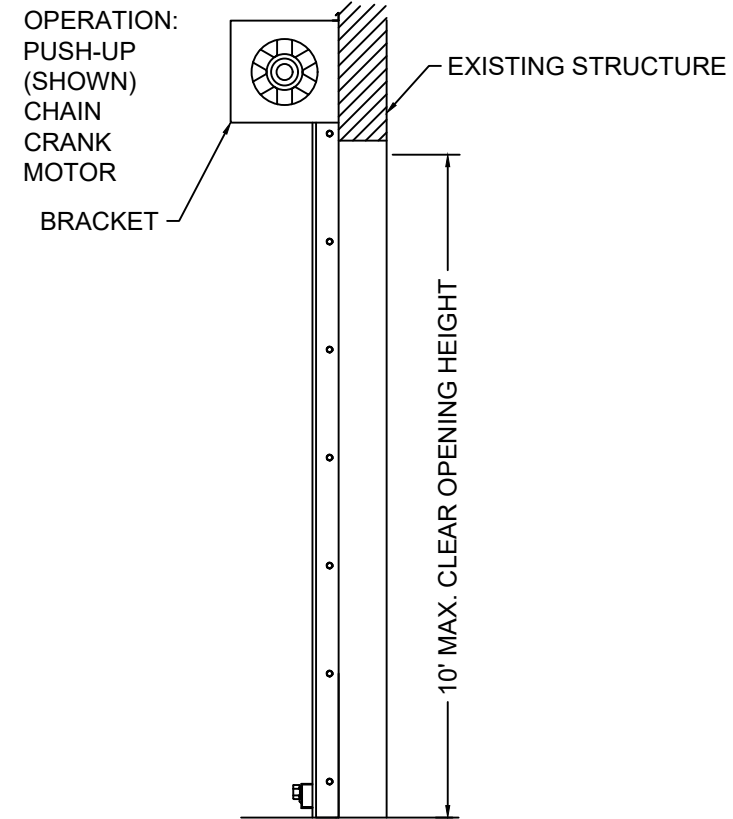

② SLAT DETAIL  
TYPICAL SECTION

ASTM A653 HSLAS TYPE B GRADE 40 G40 OR  
 ASTM A653 HSLAS TYPE A GRADE 40 G40 OR  
 ASTM A653 STRUCTURAL STEEL GRADE 40 G40  
 OR TYPE 304 STAINLESS STEEL (MIN. YIELD 40,000 psi)  
 OR TYPE 316 STAINLESS STEEL (MIN. YIELD 40,000 psi)  
 OR TYPE 430 STAINLESS STEEL (MIN. YIELD 40,000 psi)  
 OR TYPE 201 STAINLESS STEEL (MIN. YIELD 40,000 psi)  
 FULL SCALE

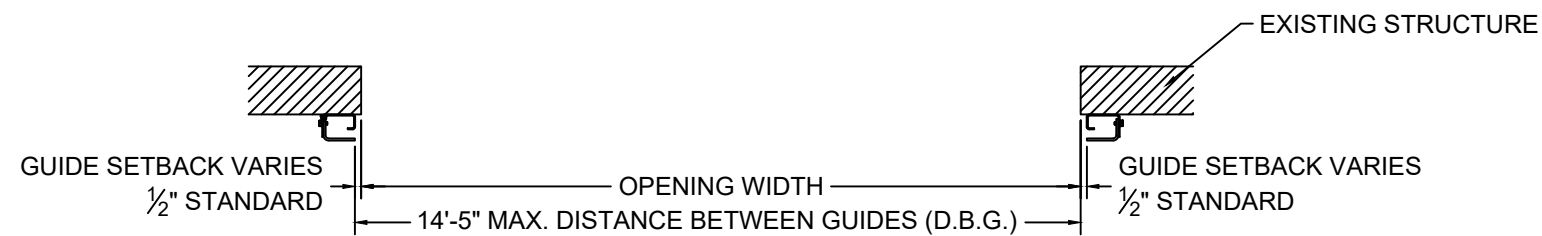

① OVERALL DOOR ASSEMBLY  
1:16 SCALE



	24 ELMWOOD AVE 1901 S. LITCHFIELD RD MOUNTAINTOP, PA GOODYEAR, AZ	Unless otherwise specified, dimensions are in inches & tolerances are:  0.000 = +/- 0.031 FRACTIONAL = +/- 1/32 ANGLES = +/- 1/2 DEG
	P: 800.390.8590 F: 866.448.6798 E: ADS@COOKSONDOOR.COM	
TITLE: WIND LOAD CONFIGURATION ROLLING STEEL COUNTER DOOR CP0005 SLAT IMPACT RATED	DRAWN BY: TJE DWG NO: ES-16-76-TCCI	SIZE: B SCALE: AS NOTED SHEET: 1/5

L'TR	REVISION	DATE	BY	E.C.O.
*	ORIGINAL ISSUE	09/02/15	TJE	1677
A	REVISED TITLE BLOCK; HOOD SUPPORT UPDATE; 2018 IBC	03/09/20	MAN	2028

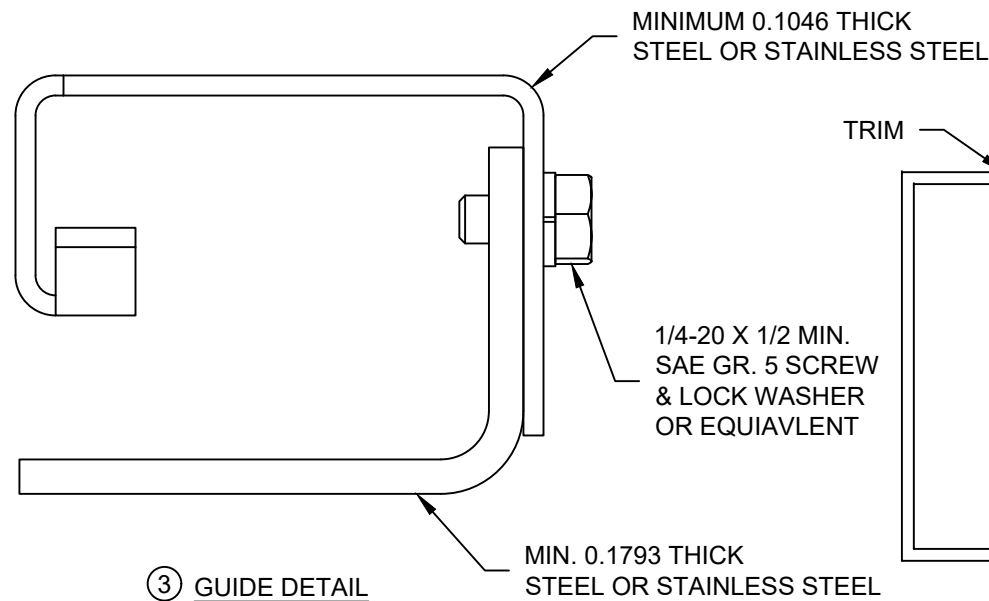

③ GUIDE DETAIL  
ASTM A1011 CS TYPE B STEEL OR  
TYPE 304 STAINLESS STEEL OR  
TYPE 316 STAINLESS STEEL

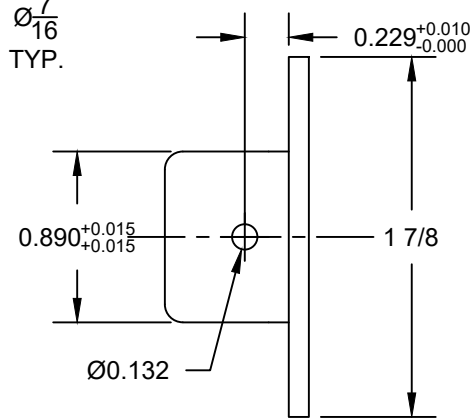
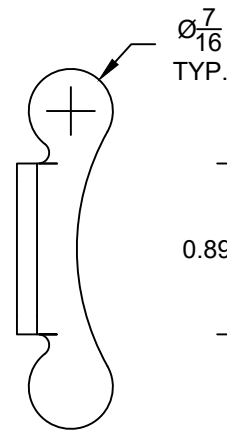
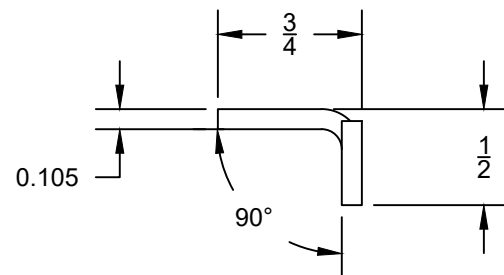
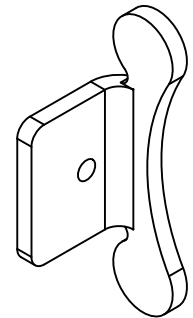

⑥ ENDLOCK DETAIL  
ASTM A1011 CS TYPE B STEEL OR  
ASTM A1008 TYPE B STEEL  
GALVANIZED IN ACCORDANCE WITH  
ASTM A123, G90 ZINC COATING  
OR TYPE 304 STAINLESS STEEL OR  
TYPE 316 STAINLESS STEEL

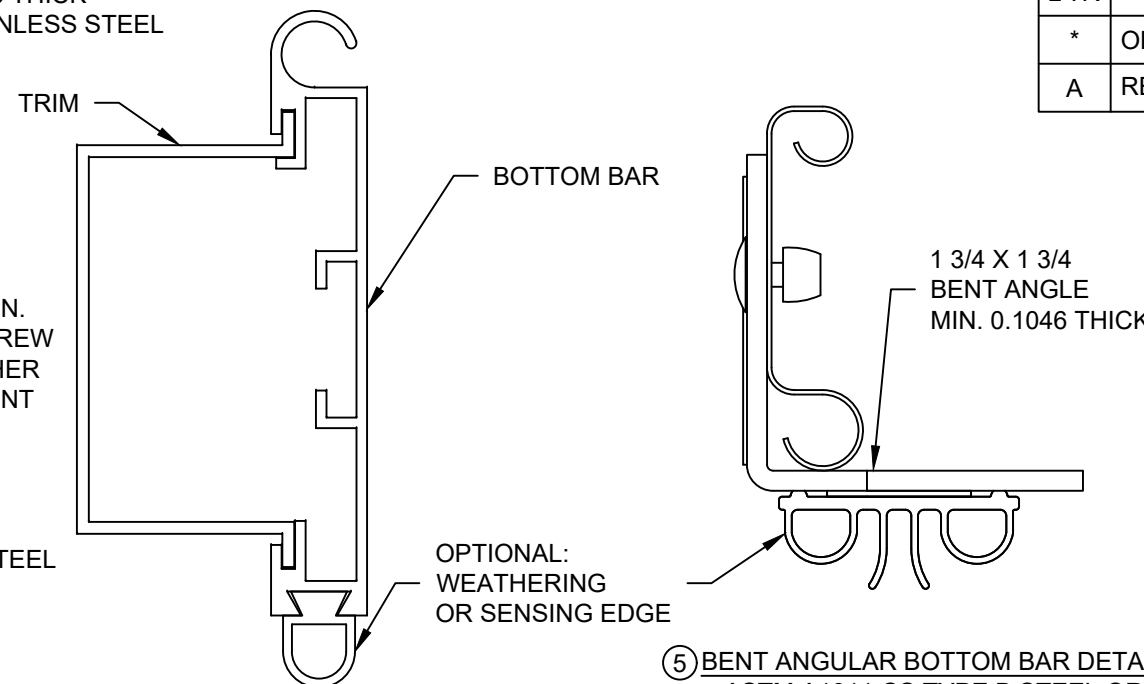

④ EXTRUDED BOTTOM BAR DETAIL  
ALUMINUM 6063-T6

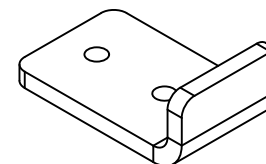
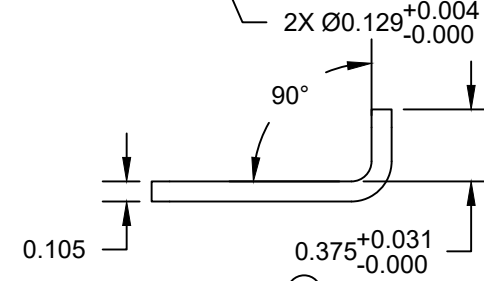
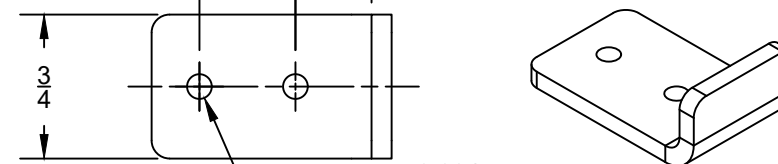

⑦ WIND-LOCK DETAIL  
ASTM A1011 CS TYPE B STEEL OR  
ASTM A1008 TYPE B STEEL  
GALVANIZED IN ACCORDANCE WITH ASTM A123, G90 ZINC COATING  
OR TYPE 304 STAINLESS STEEL OR  
TYPE 316 STAINLESS STEEL



**GENERAL NOTES:**

1. THESE PRODUCT EVALUATION DOCUMENTS REPRESENT A ROLL-UP DOOR ASSEMBLY DESIGNED AND TESTED IN ACCORDANCE WITH THE STANDARD BUILDING CODE, THE 2018 INTERNATIONAL BUILDING CODE, AND THE FLORIDA BUILDING CODE.
2. THIS ROLL-UP DOOR HAS BEEN TESTED FOR UNIFORM STATIC PRESSURE, IMPACT AND FATIGUE RESISTANCE IN ACCORDANCE WITH THE FBC TEST PROTOCOLS FOR HIGH VELOCITY HURRICANE ZONES TAS 201, TAS 202, AND TAS 203.
3. ANALYSIS OF FASTENERS AND COMPONENTS IS BASED ON A MAXIMUM 40 PSF DESIGN WIND PRESSURE AND APPLICABLE TESTED LOADING CONDITIONS, AS NOTED.
4. A 33% INCREASE IN ALLOWABLE STRESS HAS NOT BEEN USED IN THE DESIGN OF THIS PRODUCT.
5. DETERMINE THE POSITIVE AND NEGATIVE DESIGN LOADS TO USE WHEN REFERENCING THESE DOCUMENTS IN ACCORDANCE WITH THE GOVERNING CODE AND GOVERNING WIND VELOCITY.
6. THESE PRODUCT EVALUATION DOCUMENTS ARE PREPARED BY THE PRODUCT ENGINEER AND ARE GENERIC. THEY DO NOT INCLUDE INFORMATION PREPARED FOR A SPECIFIC SITE.
7. THESE PRODUCT EVALUATION DOCUMENTS ARE NOT VALID FOR PERMIT WITHOUT ORIGINAL SIGNATURE, DATE AND EMBOSSED SEAL ON EACH PERMIT COPY, WHETHER OR NOT A MASTER APPROVAL DOCUMENT IS ON FILE WITH A MUNICIPALITY OR OTHER GOVERNING AGENCY.
8. THESE PRODUCT EVALUATION DOCUMENTS ARE SUITABLE TO BE APPLIED BY THE CONTRACTOR PROVIDED THE CONTRACTOR DOES NOT DEVIATE FROM THE CONDITIONS DETAILED HEREIN AND THE CONTRACTOR VERIFIES THE EXISTING STRUCTURE IS CAPABLE OF SUPPORTING THE SUPERIMPOSED LOADS Vx & Vy ON THE JAMBS OF THE DOOR.
9. ALTERATIONS OR ADDITIONS TO THIS DOCUMENT ARE NOT PERMITTED.
10. WHEN THE SITE CONDITIONS DEVIATE FROM THESE PRODUCT EVALUATION DOCUMENTS, SITE SPECIFIC DOCUMENTS SHALL BE PREPARED BY A DULY LICENSED AND REGISTERED ENGINEER OR ARCHITECT.
11. IF THE DEVIATING SITE SPECIFIC DOCUMENTS ARE PREPARED BY A DELEGATED REGISTERED ENGINEER OR ARCHITECT, SAID DOCUMENTS SHALL BEAR THE DATE, SIGNATURE, AND EMBOSSED SEAL OF THE DELEGATED ENGINEER OR ARCHITECT AND SHALL BE SUBMITTED TO THE PROJECT ENGINEER FOR REVIEW.
12. ALL BOLTS AND WASHERS SHALL BE GALVANIZED STEEL OR STAINLESS STEEL WITH A MINIMUM TENSILE STRENGTH OF 60 K.S.I.
13. ALL WINDLOCK RIVETS SHALL BE 1/8" RIVETS IFI GRADE 30, 50, or 51 WITH A MINIMUM TENSILE STRENGTH OF 425 Lbs., AND SHEAR STRENGTH OF 295 Lbs., U.O.N.. RIVETS TO BE INSTALLED IN ALL WINDLOCK HOLES.
14. ALL WELDING SHALL BE PERFORMED BY QUALIFIED WELDERS IN ACCORDANCE WITH A.W.S. SPECIFICATIONS, LATEST EDITION. ALL WELDING ELECTRODES SHALL CONFORM TO A.W.S. A5.1 GRADE E-70. MINIMUM WELDING PROCESSES SHALL BE ARC WELDING A.W.S. E7014 OR MIG WELDING A.W.S. ER70S-6.
15. ANCHOR NOTES:  
A. EMBEDMENT LENGTH DOES NOT INCLUDE STUCCO FINISH.  
B. ANCHORS SHALL BE INSTALLED IN ACCORDANCE WITH MANUFACTURERS SPECIFICATIONS.
16. DOOR MAY BE INSTALLED ON THE INSIDE OR OUTSIDE OF AN EXTERIOR WALL



24 ELMWOOD AVE 1901 S. LITCHFIELD RD  
MOUNTAINTOP, PA GOODYEAR, AZ

P: 800.390.8590  
F: 866.448.6798  
E: ADS@COOKSONDOOR.COM

Unless otherwise specified,  
dimensions are in inches &  
tolerances are:

0.000 = +/- 0.031  
FRACTIONAL = +/- 1/32  
ANGLES = +/- 1/2 DEG

TITLE: **WIND LOAD CONFIGURATION  
ROLLING STEEL COUNTER DOOR  
CP0005 SLAT IMPACT RATED**

DRAWN BY: <b>TJE</b>	SIZE: <b>B</b>	SCALE: <b>1:1</b>	SHEET: <b>2/5</b>
-------------------------	-------------------	----------------------	----------------------

DWG NO: **ES-16-76-TCCI**

L'TR	REVISION	DATE	BY	E.C.O.
*	ORIGINAL ISSUE	09/02/15	TJE	1677
A	REVISED TITLE BLOCK; HOOD SUPPORT UPDATE; 2018 IBC	03/09/20	MAN	2028

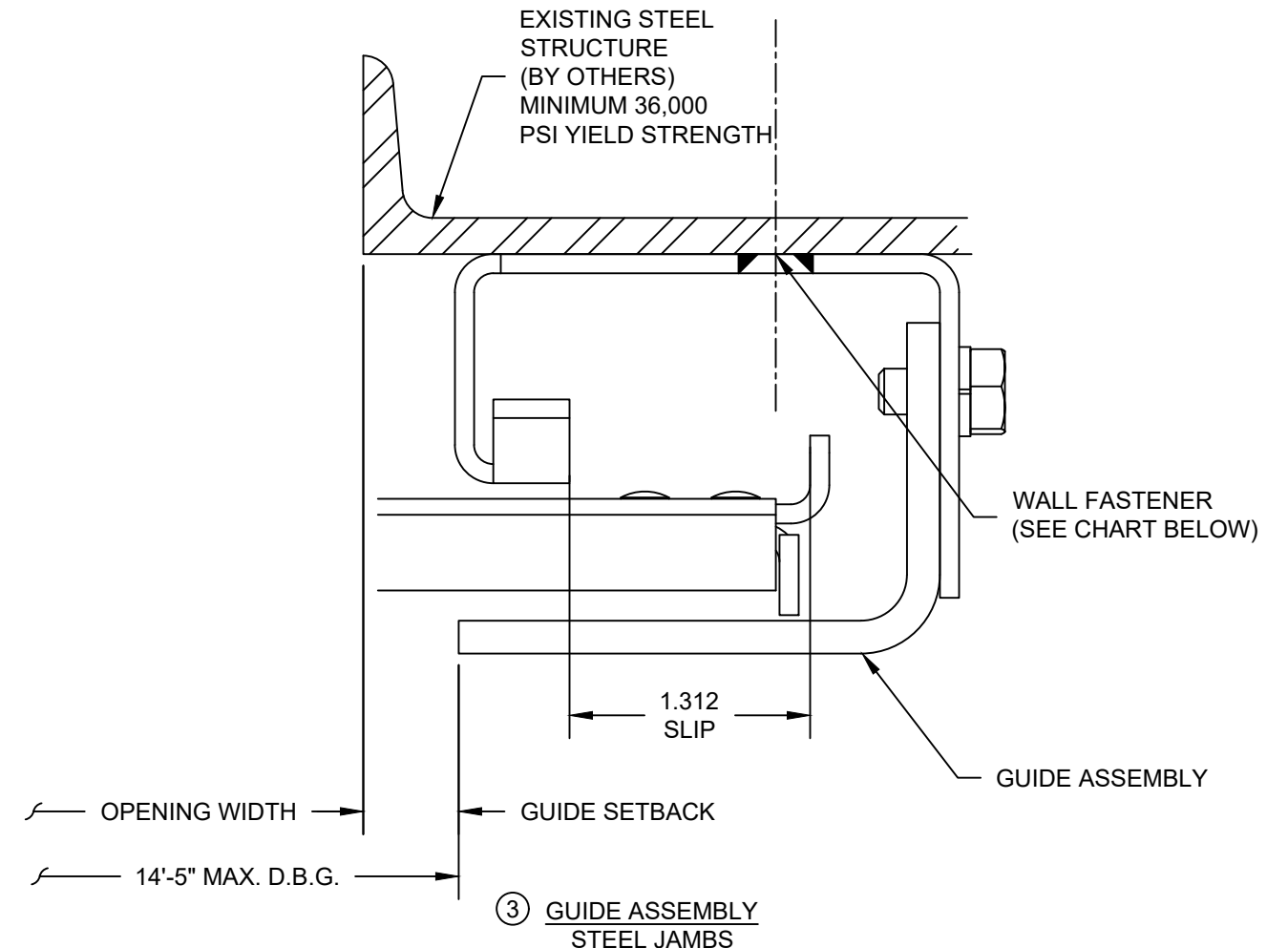
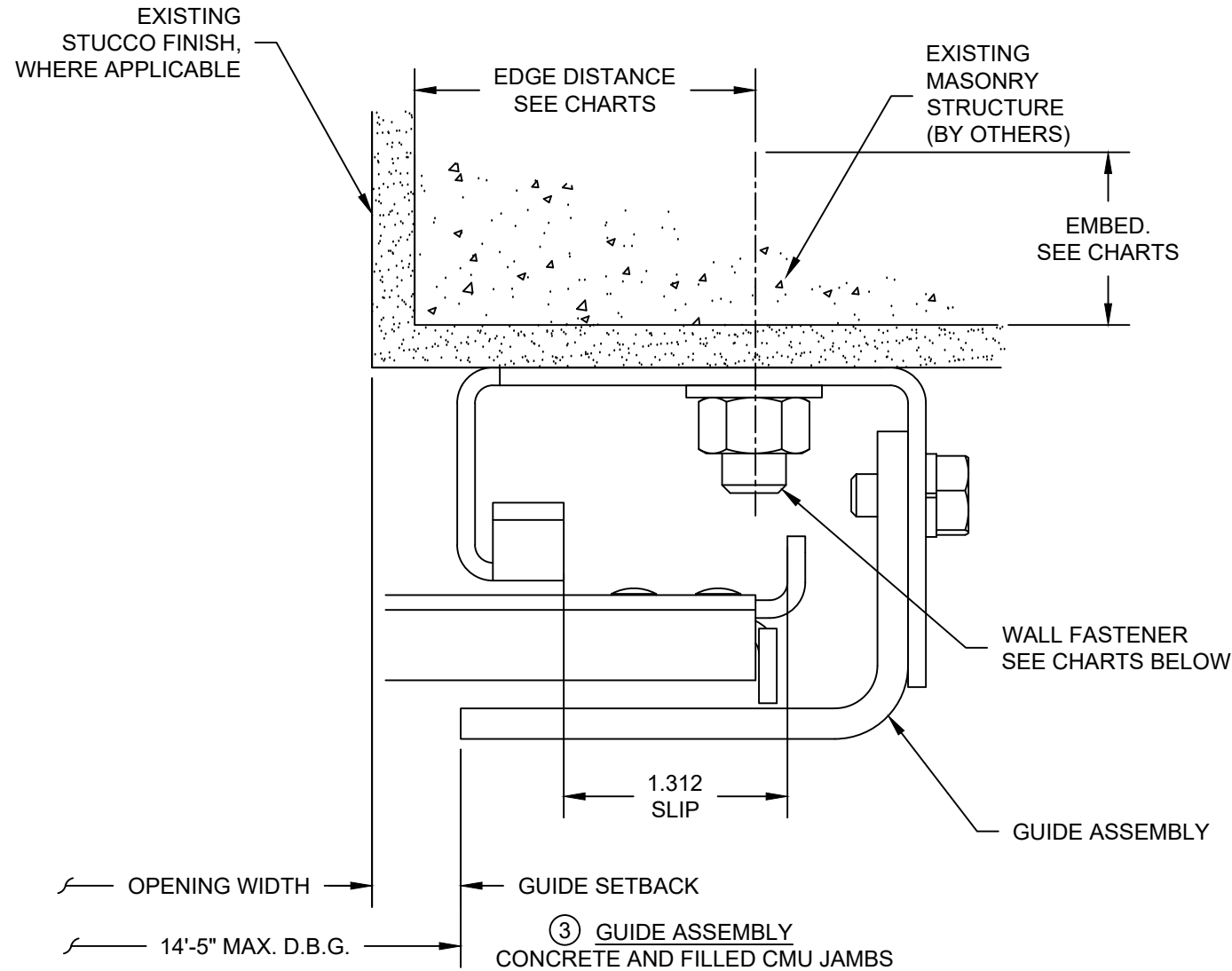

MAXIMUM CONCRETE FASTENER SPACING					
MIN. CONCRETE STRENGTH (psi)	SIMPSON WEDGE ALL (2 5/8 MIN EMBED)		HILTI KWIK BOLT 3 (2 3/8 MIN. EMBED)		ITW REDHEAD TRUBOLT (3 MIN. EMBED)
	1 3/4 MIN. EDGE DISTANCE	2 1/4 MIN. EDGE DISTANCE	1 3/4 MIN. EDGE DISTANCE	2 1/4 MIN. EDGE DISTANCE	2 1/4 MIN. EDGE DISTANCE
2000	10 (9 1/2)	12 (11)	12	12	11
3000	11 ( 11)	12 (12)	12	12	12

NOTE: ALL SPACINGS ARE BASED ON CARBON STEEL ANCHORS. STAINLESS STEEL SIMPSON ANCHORS MAY BE PROVIDED WITH THE SPACING LISTED IN THE PARENTHESIS (). STAINLESS STEEL HILTI ANCHORS ARE NOT AVAILABLE UNDER THIS APPROVAL. STAINLESS STEEL ITW REDHEAD ANCHORS MAY BE PROVIDED WITH THE LISTED SPACING.

MAXIMUM FILLED CMU FASTENER SPACING		
MIN. JAMB STRENGTH (psi)	4 MIN. EDGE DISTANCE	
	HILTI KWIK BOLT 3 (2 1/2 MIN. EMBED)	SIMPSON STRONG BOLT 2 (2 5/8 MIN. EMBED)
1500	8	8

NOTE: ALL SPACINGS ARE BASED ON CARBON STEEL ANCHORS. STAINLESS STEEL ANCHORS ARE NOT AVAILABLE UNDER THIS APPROVAL.

STEEL FASTENER SPACING			
FASTENER	3/8-16 SCREW (THROUGH BOLTED)	3/8-16 SCREW (DRILLED & TAPPED)	1/8" FILLET WELD FULLY AROUND SLOT
MIN. JAMB MAT. THICK.	1/8	1/8	1/8
SPACING	12	8	12



**COOKSON**  
Preferred door solutions™

24 ELMWOOD AVE 1901 S. LITCHFIELD RD  
MOUNTAINTOP, PA GOODYEAR, AZ

P: 800.390.8590  
F: 866.448.6798  
E: ADS@COOKSONDOOR.COM

Unless otherwise specified, dimensions are in inches & tolerances are:

0.000 = +/- 0.031  
FRACTIONAL = +/- 1/32  
ANGLES = +/- 1/2 DEG

TITLE: **WIND LOAD CONFIGURATION ROLLING STEEL COUNTER DOOR CP0005 SLAT IMPACT RATED**

DRAWN BY: **TJE**    SIZE: **B**    SCALE: **1:1**    SHEET: **3/5**

DWG NO: **ES-16-76-TCCI**

L'TR	REVISION	DATE	BY	E.C.O.
*	ORIGINAL ISSUE	09/02/15	TJE	1677
A	REVISED TITLE BLOCK; HOOD SUPPORT UPDATE; 2018 IBC	03/09/20	MAN	2028

EXISTING STRUCTURE (BY OTHERS)

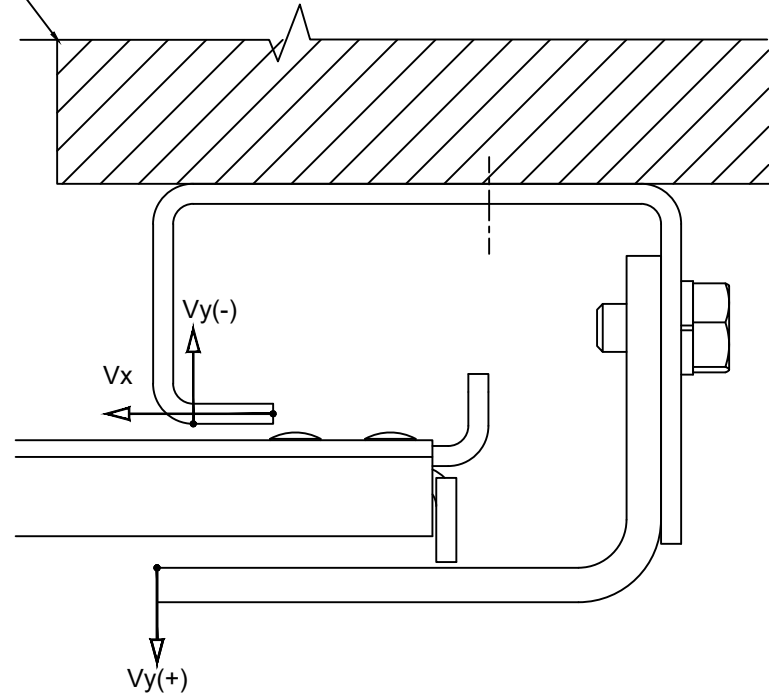

③ SUPERIMPOSED LOAD DIAGRAM

NOTE:  
 $V_x$  &  $V_y$  ARE IN-PLANE AND OUT-OF-PLANE COMPONENTS OF THE REACTION, RESPECTIVELY, RESULTING FROM WIND LOADS ON THE ROLL-UP DOOR. THE EXISTING STRUCTURE SHALL BE CAPABLE OF RESISTING  $V_x$  &  $V_y$  FORCES SHOWN AND THE CORRESPONDING REACTIONS DUE TO THE ECCENTRICITIES OF THESE FORCES.

DESIGN AND/OR ANALYSIS OF EXISTING STRUCTURE(S) SHALL BE THE RESPONSIBILITY OF OTHERS.

UNREDUCED WIND FORCES ON BUILDING STRUCTURE (LBS/ FOOT OF HEIGHT)			
POSITIVE		NEGATIVE	
$V_x$	521	$V_x$	523
$V_y$	287	$V_y$	287

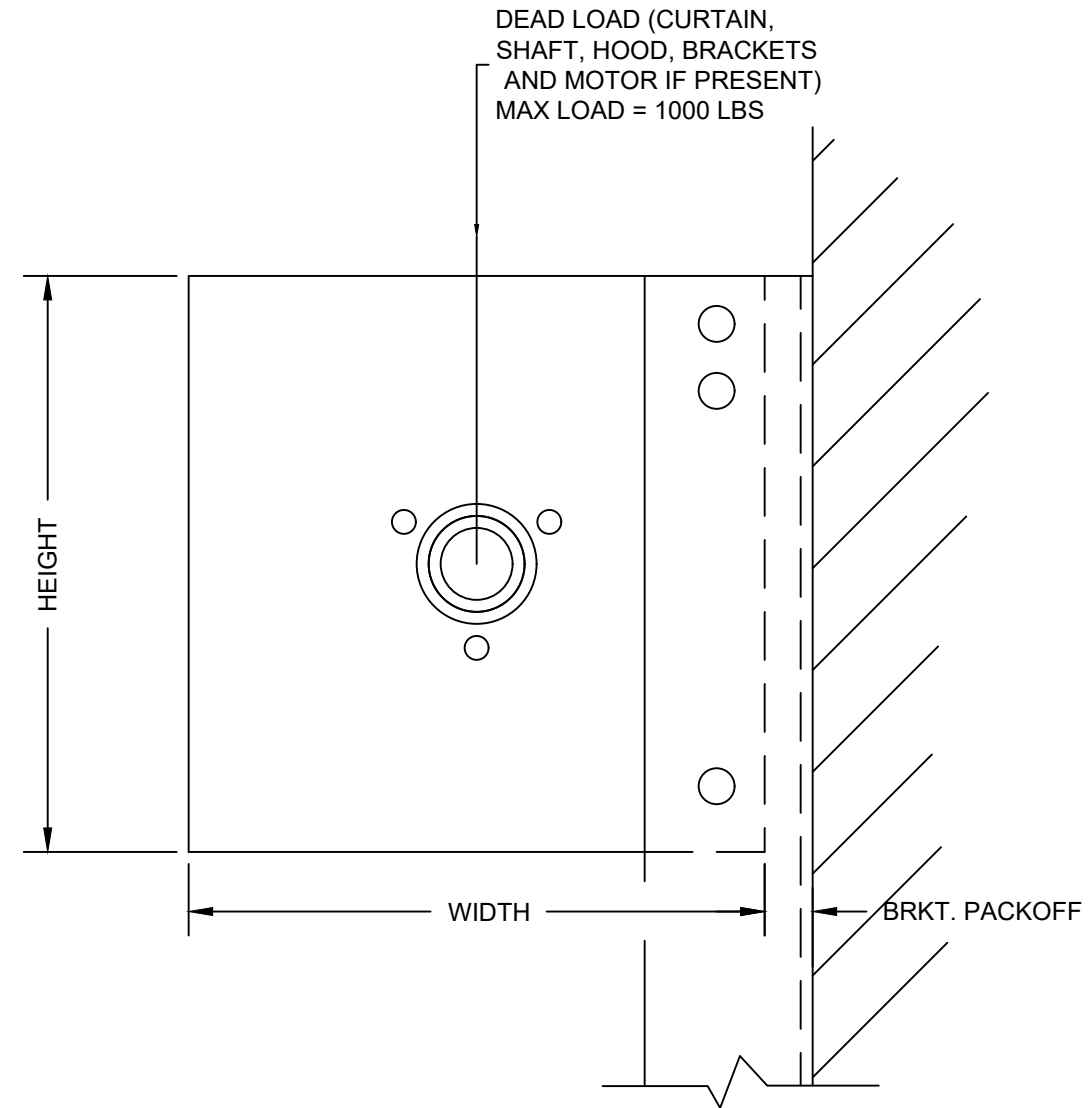

NOTE:  
 BRACKET HEIGHT AND WIDTH DIMENSION ARE TYPICALLY EQUAL TO COIL DIMENSION (14" MAXIMUM) ACUTAL DIMENSION MAY INCREASE BASED ON OPERATION METHOD OF DOOR.



	24 ELMWOOD AVE 1901 S. LITCHFIELD RD MOUNTAINTOP, PA GOODYEAR, AZ	Unless otherwise specified, dimensions are in inches & tolerances are:  0.000 = +/- 0.031 FRACTIONAL = +/- 1/32 ANGLES = +/- 1/2 DEG		
	P: 800.390.8590 F: 866.448.6798 E: ADS@COOKSONDOOR.COM			
TITLE: WIND LOAD CONFIGURATION ROLLING STEEL COUNTER DOOR CP0005 SLAT IMPACT RATED	DRAWN BY: TJE	SIZE: B	SCALE: NTS	SHEET: 4/5
DWG NO: ES-16-76-TCCI				



L'TR	REVISION	DATE	BY	E.C.O.
*	ORIGINAL ISSUE	09/02/15	TJE	1677
A	REVISED TITLE BLOCK; HOOD SUPPORT UPDATE; 2018 IBC	03/09/20	MAN	2028

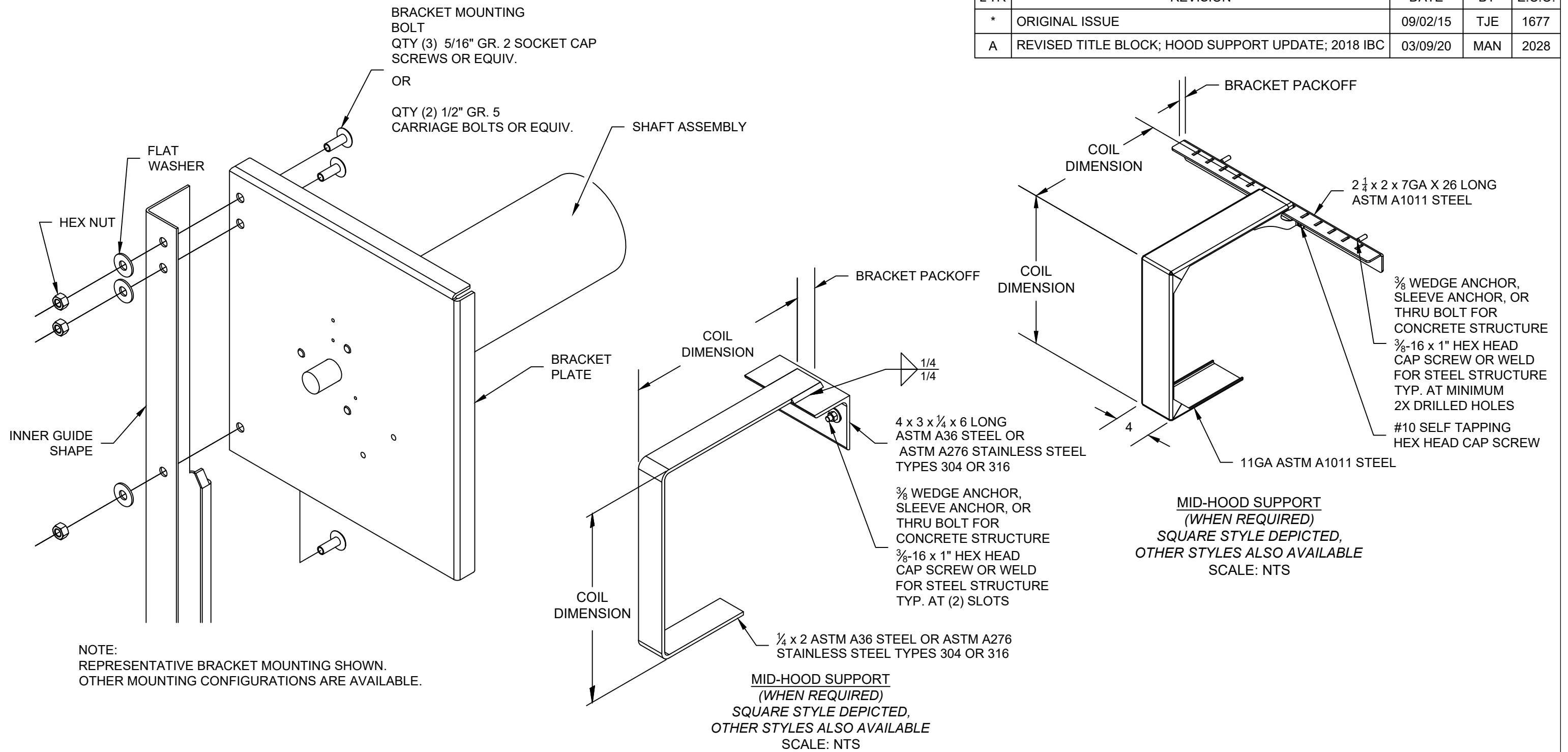

	24 ELMWOOD AVE 1901 S. LITCHFIELD RD MOUNTAINTOP, PA GOODYEAR, AZ	Unless otherwise specified, dimensions are in inches & tolerances are:  0.000 = +/- 0.031 FRACTIONAL = +/- 1/32 ANGLES = +/- 1/2 DEG
	P: 800.390.8590 F: 866.448.6798 E: ADS@COOKSONDOOR.COM	
TITLE: WIND LOAD CONFIGURATION ROLLING STEEL COUNTER DOOR CP0005 SLAT IMPACT RATED	DRAWN BY: TJE DWG NO: ES-16-76-TCCI	SIZE: B SCALE: NTS SHEET: 5/5