

NOTES:

- VINYL OR WOOD DOOR STOP NAILED A MAXIMUM OF 6" O.C. MUST OVERLAP TOP AND BOTH ENDS OF PANELS MINIMUM 7/16" TO MEET NEGATIVE PRESSURES.
- SLIDE LOCK OR OPERATOR REQUIRED. LOW HEADROOM REQUIRES A LOCK ON THE LEFT AND RIGHT SIDE OF THE DOOR.
- THE DESIGN OF THE SUPPORTING STRUCTURAL ELEMENTS SHALL BE THE RESPONSIBILITY OF THE PROFESSIONAL OF RECORD FOR THE BUILDING OR STRUCTURE AND IN ACCORDANCE WITH CURRENT BUILDING CODES FOR THE LOADS LISTED ON THIS DRAWING.
- SECTION STEEL TO HAVE THE FOLLOWING MINIMUM THICKNESS:
EXTERIOR - 27 GA
INTERIOR - 30 GA
- DOOR JAMB TO BE MINIMUM 2x6 STRUCTURAL GRADE LUMBER AND BE SPRUCE, PINE, OR FIR. REFER TO JAMB CONNECTION SUPPLEMENT FOR ATTACHMENT TO SUPPORTING STRUCTURE.
- FOR LOW HEAD ROOM LIFT CONDITIONS, TOP BRACKET SHALL BE A LHR TOP BRACKET IN LIEU OF THE BRACKET SHOWN ON THIS DRAWING. SEE LHR, DETAIL A, SHEET 2.
- GLAZING OPTIONS - .125" MINIMUM TEMPERED GLAZING INSTALLED IN TOP SECTION (WITH OR WITHOUT DECORATIVE LITE FRAME DIVIDERS) MEETS UNIFORM STATIC WIND PRESSURES SHOWN ON THIS DRAWING. GLAZING IS NOT IMPACT RESISTANT AND DOES NOT MEET THE REQUIREMENTS FOR WIND-BORNE DEBRIS REGIONS. MAX CLEAR OPENING 43-1/4" X 19-1/4".
- 11 GA ROLLER SLIDES WITH WELDED ENDS AND 11 GA REINFORCING BRACKETS REQUIRED FOR DOORS >8' TALL.

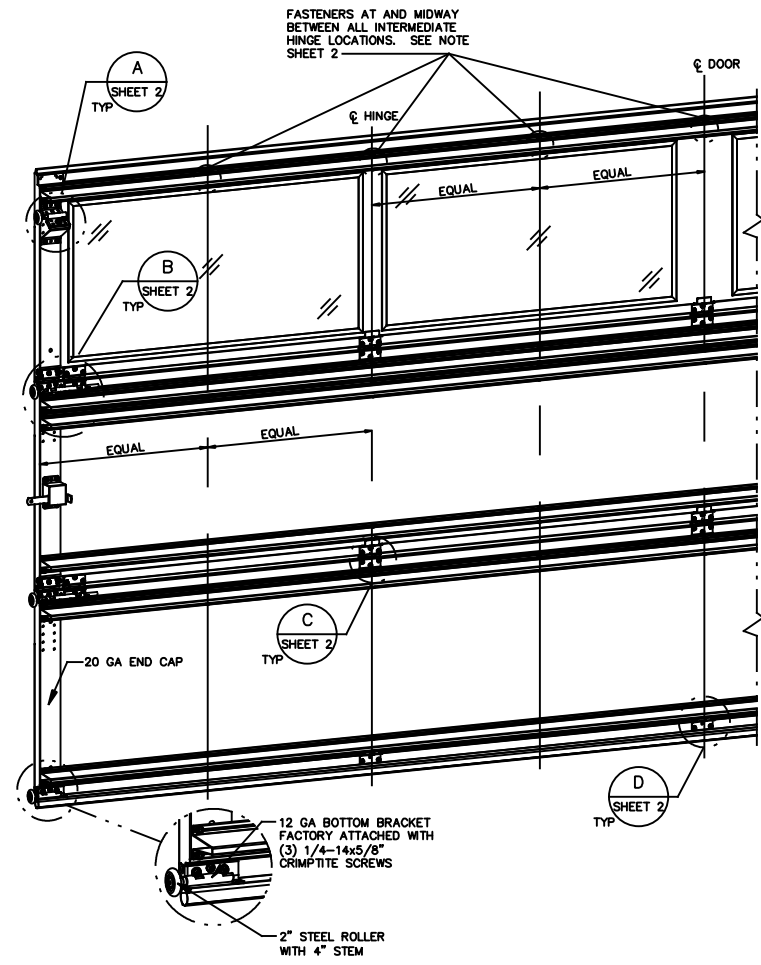
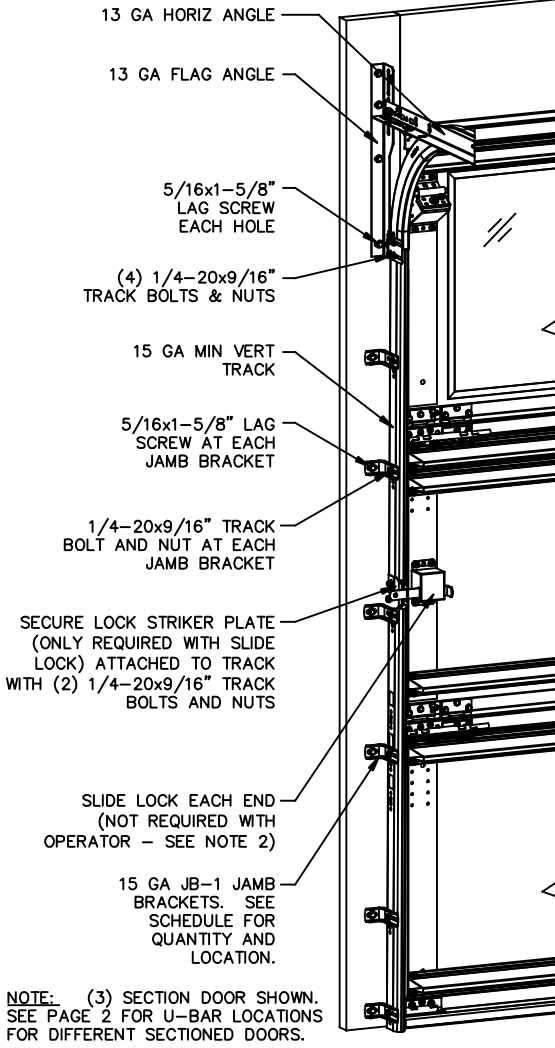

REVISIONS
POO CREATED NEW DRAWING FOR WINDLOAD OPTIONS 8-24-16 GAC

DOOR HEIGHT	NO. OF SECTIONS	NO. OF JAMB BRACKETS (EACH JAMB)	LOCATION OF CENTERLINE OF JAMB BRACKETS MEASURED FROM BOTTOM OF TRACK (ALL DIMENSIONS ± 2")
7'-0"	3	6	2", 10", 26", 42", 53", 63"
8'-0"	4	8	2", 10", 26", 39", 48", 57", 66", 75"
> 8'-0"			SEE NOTE BELOW

NOTE: ALL DOORS GREATER THAN 8' IN HEIGHT REQUIRE USE OF CONTINUOUS WALL ANGLE. SEE SUPPLEMENT TRACK CHART FOR DETAILS.

DOOR WIDTH	DOOR HEIGHT	UNIFORM LOAD EACH JAMB (PLF)
18'-0"	7'-0"	+137.7/-153.0
	8'-0"	+137.7/-153.0



Louisville, TX

PROFESSIONAL ENGINEER'S SEAL PROVIDED ONLY FOR VERIFICATION OF WINDLOAD CONSTRUCTION DETAILS.

This door has been tested per ANSI/DASMA 108

STATIC PRESSURE RATINGS		APPROVED SIZES		SCALE: N.T.S.		SIZE: A	
DESIGN (PSF):	+15.30/-17.00	MAX WIDTH:	18'-0"	DATE	8-24-16	NAME	GAC
IMPACT/CYCLIC RATED (YES/NO): NO		MAX HEIGHT:	14'-0"	DRAWN	8-24-16	DK	
		MAX SECTION HEIGHT:	28"	CHECKED	8-24-16		
MODELS 300-309/5800				SHEET 1 OF 2			
WINDLOAD SPECIFICATION				DRAWING PART NO.		REV.	
				411441		P00	

JOHN E. SCATES, PE
3121 FAIRGATE DR.
CARROLLTON, TX 75007
FL PE 51737 TX PE 56308/F-2203

LOW HEADROOM TRACK

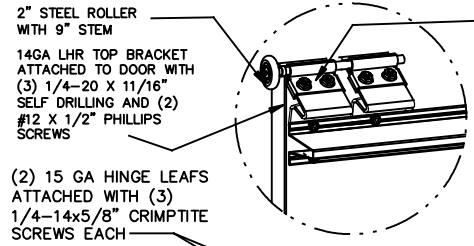

13 GA ROLLER SLIDE ATTACHED TO BRACKET WITH 5/16-18 BOLT & NUT IN CENTER SLOT AND 1/4-20x9/16" TRACK BOLT & NUT THROUGH ANY TWO ALIGNING HOLES

(2) 15 GA HINGE LEAFS ATTACHED WITH (3) 1/4-14x5/8" CRIMPTITE SCREWS EACH

14 GA HINGE BASE FACTORY ATTACHED TO DOOR WITH (5) 1/4-14x5/8" CRIMPTITE SCREWS

2" STEEL ROLLER WITH 9" STEM

13 GA ROLLER CARRIERS FACTORY ATTACHED TO HINGE BASE AND REINFORCING BRACKET. (EXCEPTION: NOTE #8)

BEFORE U-BAR INSTALLATION

13 GA REINFORCING BRACKET ATTACHED BENEATH HINGE BASE. (EXCEPTION: NOTE #8)

15 GA HINGE ATTACHED WITH (6) 1/4-14x5/8" CRIMPTITE SCREWS (3 OF WHICH ARE FACTORY ATTACHED)

BEFORE U-BAR INSTALLATION

STANDARD LIFT TRACK

2" STEEL ROLLER WITH 4" STEM

13 GA COMMERCIAL 'A' FRAME TOP BRACKET ATTACHED WITH (4) 1/4-20x7/8" SELF DRILLING SCREWS

13 GA ROLLER SLIDE ATTACHED TO BRACKET WITH 5/16-18 BOLT & NUT IN CENTER SLOT AND 1/4-20x9/16" TRACK BOLT & NUT THROUGH ANY TWO ALIGNING HOLES

DETAIL A

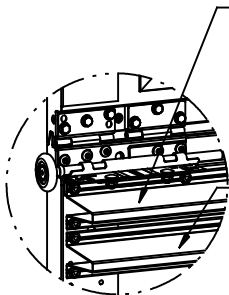

POSITION TOP U-BAR OVER REINFORCING BRACKET AND ATTACH WITH (3) 1/4-20x7/8" SELF DRILLING SCREWS AS SHOWN (2 OF WHICH ATTACH THROUGH REINFORCING BRACKET)

POSITION SECOND U-BAR ADJACENT TO TOP U-BAR

DETAIL B



POSITION U-BAR ADJACENT TO HINGE LEAF AND ATTACH WITH (2) 1/4-14x5/8" CRIMPTITE SCREWS AS SHOWN

POSITION U-BAR OVER HINGE LEAF AND ATTACH WITH (1) 1/4-14x5/8" CRIMPTITE SCREW AND (1) 1/4-20x7/8" SELF DRILLING SCREW AS SHOWN (SELF DRILLING SCREW ATTACHES THROUGH HINGE LEAF)

AFTER U-BAR INSTALLATION

DETAIL C

15 GA HINGE BRACKET ATTACHED WITH (2) 1/4-20x7/8" SELF DRILLING SCREWS

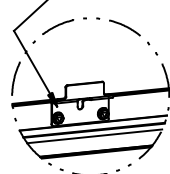

BEFORE U-BAR INSTALLATION

POSITION U-BAR OVER HINGE BRACKET AND ATTACH WITH (1) 1/4-14x5/8" CRIMPTITE SCREW AND (1) 1/4-20x7/8" SELF DRILLING SCREW AS SHOWN (SELF DRILLING SCREW ATTACHES THROUGH HINGE BRACKET)

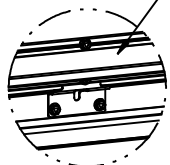

AFTER U-BAR INSTALLATION

DETAIL D

U-BAR LOCATIONS

(7) SECTION DOORS WITH (14) 3" 20 GA 80 KSI U-BARS LOCATED AS SHOWN (TOP BRACKET REMOVED FOR CLARITY)

(6) SECTION DOORS WITH (12) 3" 20 GA 80 KSI U-BARS LOCATED AS SHOWN (TOP BRACKET REMOVED FOR CLARITY)

(5) SECTION DOORS WITH (10) 3" 20 GA 80 KSI U-BARS LOCATED AS SHOWN (TOP BRACKET REMOVED FOR CLARITY)

(4) SECTION DOORS WITH (8) 3" 20 GA 80 KSI U-BARS LOCATED AS SHOWN (TOP BRACKET REMOVED FOR CLARITY)

(3) SECTION DOORS WITH (6) 3" 20 GA 80 KSI U-BARS LOCATED AS SHOWN (TOP BRACKET REMOVED FOR CLARITY)

UNLESS NOTED OTHERWISE, ALL U-BARS SHALL BE ATTACHED WITH A MINIMUM OF (2) FASTENERS AT EACH END, AT ALL INTERMEDIATE HINGE LOCATIONS (OR IN LINE WITH INTERMEDIATE HINGE LOCATIONS IF U-BAR IS NOT LOCATED AT A HINGE), MIDWAY BETWEEN INTERMEDIATE HINGE LOCATIONS, AND MIDWAY BETWEEN OUTSIDE INTERMEDIATE HINGE LOCATIONS AND END OF DOOR (MINIMUM OF (18) FASTENERS EACH U-BAR). ALL FASTENERS USED TO ATTACH U-BARS SHALL BE 1/4-14x5/8" CRIMPTITE SCREWS EXCEPT 1/4-20x7/8" SELF DRILLING SCREWS SHALL BE USED AT END CAPS AND WHERE FASTENING THROUGH HINGE LEAFS OR BRACKETS.

NOTE: U-BARS SHOULD BE INSTALLED LEVEL ACROSS DOOR AND MAINTAIN A MINIMUM CENTERLINE SPACING OF 6-5/8" BETWEEN U-BARS ON ADJACENT SECTIONS

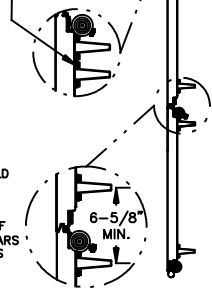

JOHN E. SCATES, PE
3121 FAIRGATE DR.
CARROLLTON, TX 75007
FL PE 51737 TX PE 56308/F-2203

PROFESSIONAL ENGINEER'S SEAL PROVIDED ONLY FOR VERIFICATION OF WINDLOAD CONSTRUCTION DETAILS.



Lewisville, TX

STATIC PRESSURE RATINGS	APPROVED SIZES	SCALE: N.T.S.	SIZE: A
DESIGN (PSF): +15.30/-17.00	MAX WIDTH: 18'-0"	DATE	NAME
IMPACT/CYCLIC RATED (YES/NO): NO	MAX HEIGHT: 14'-0"	DRAWN	GAC
	MAX SECTION HEIGHT: 28"	CHECKED	DK
MODELS 300-309/5800		SHEET 2 OF 2	
WINDLOAD SPECIFICATION		DRAWING PART NO.	REV.
		411441	P00