

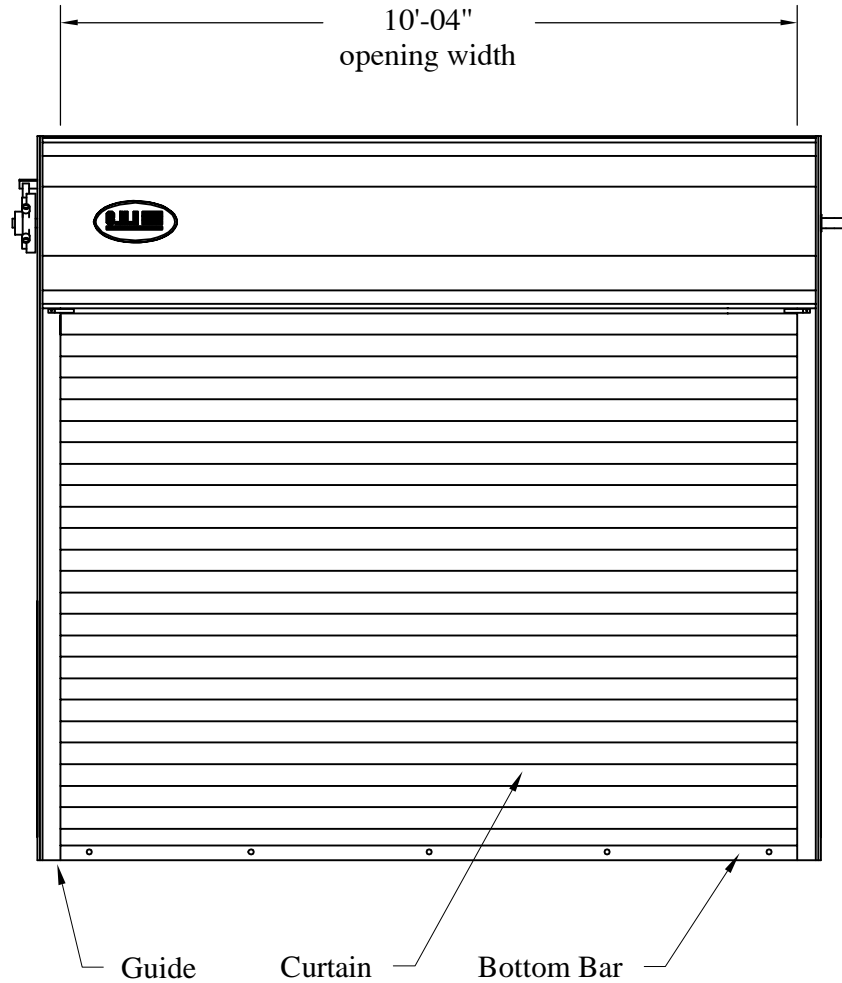

This door has been evaluated in accordance with ASTM E 330-02 and ANSI/DASMA 108-02 and 108-05. Per ASCE 7-05, Design Pressures (DP) +34.7/-43.1psf typically meet or exceed 156 mph exposure "B" requirements for 10'-04" x 8' doors.



John E. Scates, P.E.  
3121 Fairgate Drive  
Carrollton, Texas 75007  
TXPE 56308, F-2203

 <small>1485 Sunrise Drive, Arthur, IL 61911</small>	Date: 8-31-2015
	Models: 6202, 6222, 6242
10'-04" wide +34.7/-43.1psf	
C.H.I. Drawing: TZ7n-10-R1002	

Maximum door height: 24'-0"

Guide Details

**1. Jamb Material:**

Steel (3/16" thick, A500 Structural) or  
Concrete (2000psi, minimum) or  
Filled CMU (2000psi, minimum)

**2. Wall Angle: (A36 Structural Steel Angle)**

a. 3" x 3" x 3/16"

"E" Guide Configuration For Steel Jamb.

b. 3" x 3" x 3/16"

"Z" Guide Configuration For concrete Jamb.

**3. Jamb Fastener: (Quantity Shown On Page 3)**

a. Steel: 3/8"-16 x 1" Self Tapping Bolt (ASME B18.6.3)

b. Welding of Guides: 3/16" Fillet Weld  
Perimeter of Slot Utilizing an E60 Electrode.  
Slot Quantity Same as Steel.

c. Simpson Strong-Tie (Concrete) or Hilti (Filled CMU):  
3/8"x4" Simpson Strong-Tie Titen HD (concrete) or  
5/8"x5" (4" embedment) Hilti KWIK BOLT 3 (Filled CMU) or  
3/8"x3.75" (2.5" embedment) Hilti KWIK BOLT 3 (Filled CMU)

d. Through Bolt (Concrete or Filled CMU):  
3/8"-16 Bolt or Rod (minimum 115,000 psi), Nut, and .75"OD flat washers,  
with Square crush plate: 2.5"x2.5"x0.25" thick (A36 steel or better)

**4. Guide to Guide Fastener :**

3/8"-16 x 1-1/4" Grade 2 Carriage Bolt  
with Steel Serrated-Flange Hex Locknut 3/8"-16  
not to exceed 24" on centers.

**5. Back Angle: (A36 Structural Steel Angle)**

2" x 3" x 3/16"

**6. Face Angle: (A36 Structural Steel Angle)**

3" x 3" x 3/16"

**7. Slat Cut-Length:**

Slat Length = Opening Width plus 4-3/4"

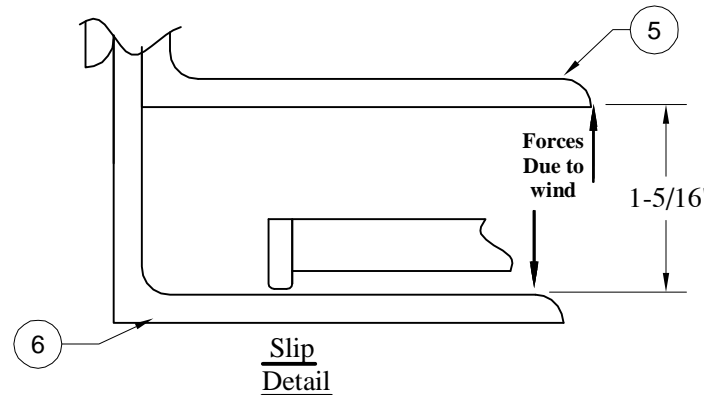
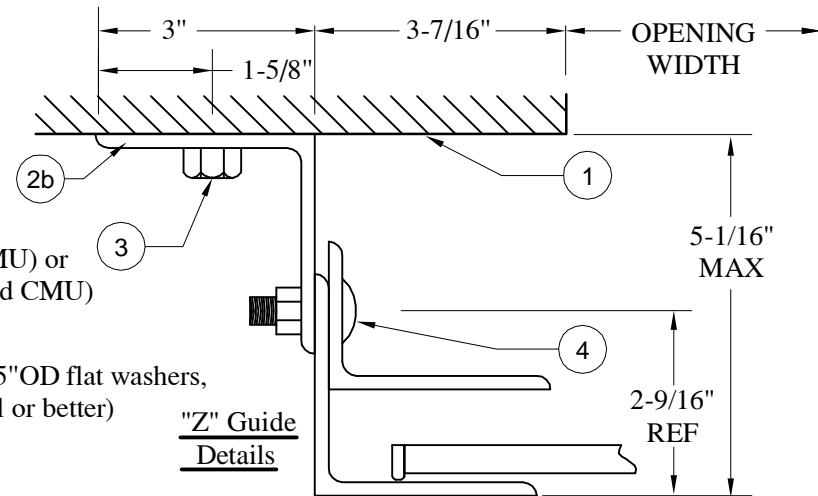
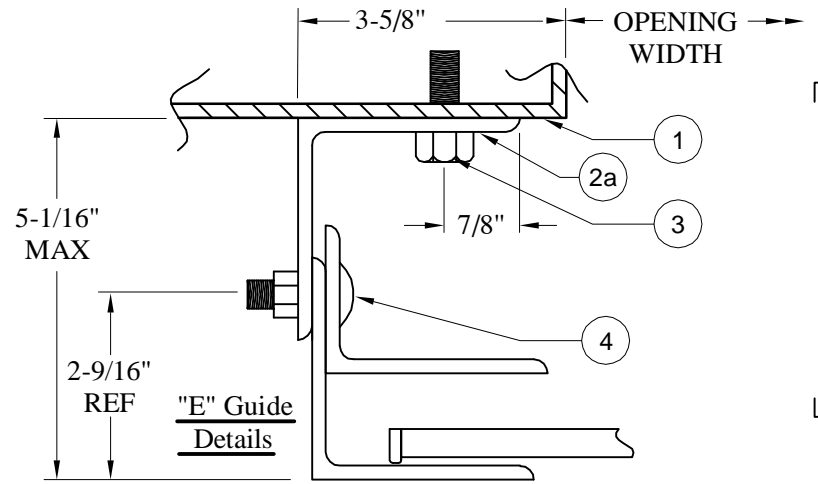

John E. Scates, P.E.  
3121 Fairgate Drive  
Carrollton, Texas 75007  
TXPE 56308, F-2203

The jambs must be designed (by others) to withstand direct forces due to wind (width x psf/2) on this door. Forces are in units of "pounds per foot tall". Direct forces due to wind occur in both (+) and (-) directions.

 <small>ROLLING STEEL DOORS</small> <small>1485 Sunrise Drive, Arthur, IL 61911</small>	Date: 8-31-2015
	Models: 6202, 6222, 6242
10'-04" wide +34.7/-43.1psf	
C.H.I. Drawing: TZ7n-10-R1002	

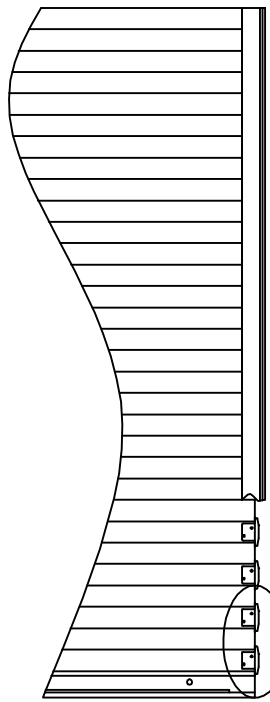

Rivet Diameter: 1/4"  
 Rivet Body: Steel  
 Rivet Mandrel: Steel  
Rivet

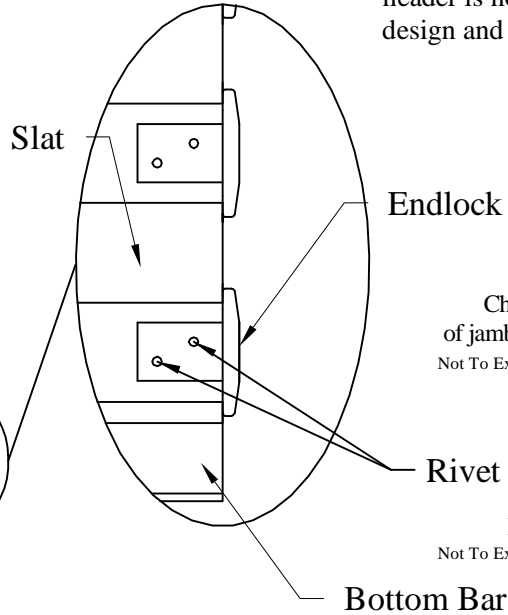

Note:  
 Construction of the door above the header is not part of the windload design and not detailed on this drawing.

Charted quantity  
 of jamb fasteners minus 1  
 Not To Exceed Maximum Spacing

Run Out  
 Not To Exceed Maximum Spacing

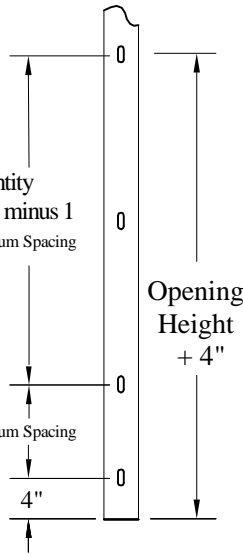

Opening Height	Quantity of Jamb Fasteners				
	steel	bolt through	2000psi concrete Simpson	2000psi filledCMU 5/8 Hilti	2000psi filledCMU 3/8 Hilti
8'-0"	3	5	5	8	13
9'-0"	4	5	6	9	15
10'-0"	4	5	7	10	16
11'-0"	4	6	7	11	18
12'-0"	4	6	8	12	19
13'-0"	5	7	8	13	22
14'-0"	5	7	9	14	24
15'-0"	5	7	9	15	25
16'-0"	5	8	10	16	26
17'-0"	6	8	11	17	28
18'-0"	6	9	12	18	29
20'-0"	6	9	13	20	32
22'-0"	7	10	14	22	35
24'-0"	7	11	15	24	39
Spacing not to exceed	48"	30"	24"	13"	8"

John E. Scates, P.E.  
 3121 Fairgate Drive  
 Carrollton, Texas 75007  
 TXPE 56308, F-2203

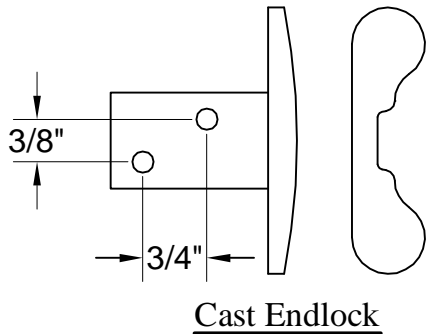

Cast Endlock

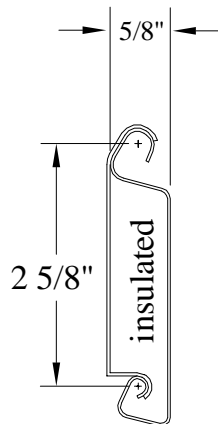

Steel Slat Thickness  
 .024/.024 insulated

5/16" x 1"  
 Grade 2  
 Carriage Bolt  
 With Flange Nut  
 Not To Exceed  
 56" On Centers.

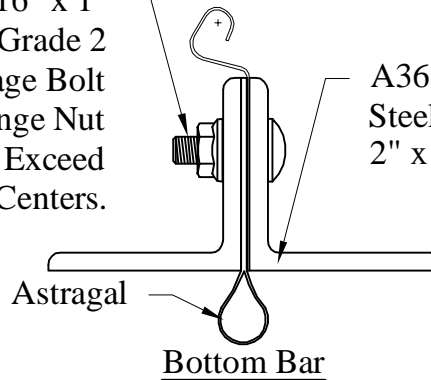

Bottom Bar



Date: 8-31-2015  
 Models: 6202, 6222, 6242

10'-04" wide +34.7/-43.1psf

C.H.I. Drawing: TZ7n-10-R1002