

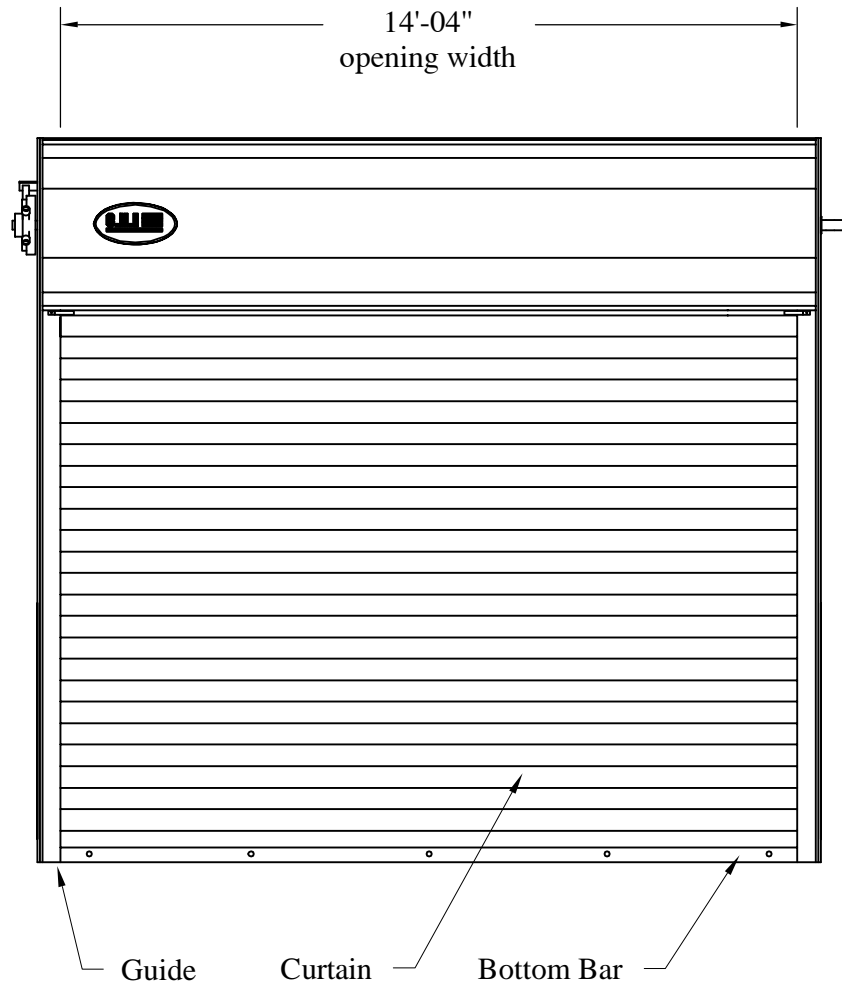

This door has been evaluated in accordance with ASTM E 330-02 and ANSI/DASMA 108-02 and 108-05. Per ASCE 7-05, Design Pressures (DP) +20.0/-24.3psf typically meet or exceed 120mph exposure "B" requirements for 14'-04" x 8' doors.



John E. Scates, P.E.
 3121 Fairgate Drive
 Carrollton, Texas 75007
 TX P.E. # 56308 F-2203

 <small>1485 Sunrise Drive, Arthur, IL 61911</small>	Date: 8-31-2015
	Models: 6181, 6201, 6221, 6266
14'-04" wide +20.0/-24.3psf	
C.H.I. Drawing: TZ4n-14-R1002	

Maximum door height: 24'-0"

Guide Details

1. Jamb Material:

Steel (3/16" thick, A500 Structural) or
Concrete (2000psi, minimum) or
Filled CMU (2000psi, minimum)

2. Wall Angle: (A36 Structural Steel Angle)

a. 3" x 3" x 3/16"

"E" Guide Configuration For Steel Jamb.

b. 3" x 3" x 3/16"

"Z" Guide Configuration For concrete Jamb.

3. Jamb Fastener: (Quantity Shown On Page 3)

a. Steel: 3/8"-16 x 1" Self Tapping Bolt (ASME B18.6.3)

b. Welding of Guides: 3/16" Fillet Weld
Perimeter of Slot Utilizing an E60 Electrode.
Slot Quantity Same as Steel.

c. Simpson Strong-Tie (Concrete) or Hilti (Filled CMU):
3/8"x4" Simpson Strong-Tie Titen HD (concrete) or
5/8"x5" (4" embedment) Hilti KWIK BOLT 3 (Filled CMU) or
3/8"x3.75" (2.5" embedment) Hilti KWIK BOLT 3 (Filled CMU)

d. Through Bolt (Concrete or Filled CMU):

3/8"-16 Bolt or Rod (minimum 115,000 psi), Nut, and .75"OD flat washers,
with Square crush plate: 2.5"x2.5"x0.25" thick (A36 steel or better)

4. Guide to Guide Fastener :

3/8"-16 x 1-1/4" Grade 2 Carriage Bolt
with Steel Serrated-Flange Hex Locknut 3/8"-16
not to exceed 24" on centers.

5. Back Angle: (A36 Structural Steel Angle)

2" x 3" x 3/16"

6. Face Angle: (A36 Structural Steel Angle)

3" x 3" x 3/16"

7. Slat Cut-Length:

Slat Length = Opening Width plus 4-3/4"

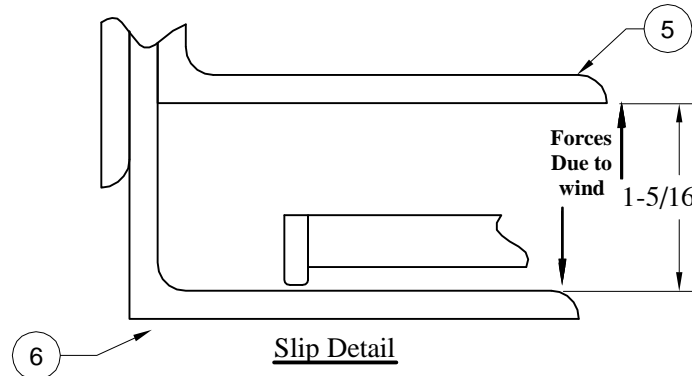
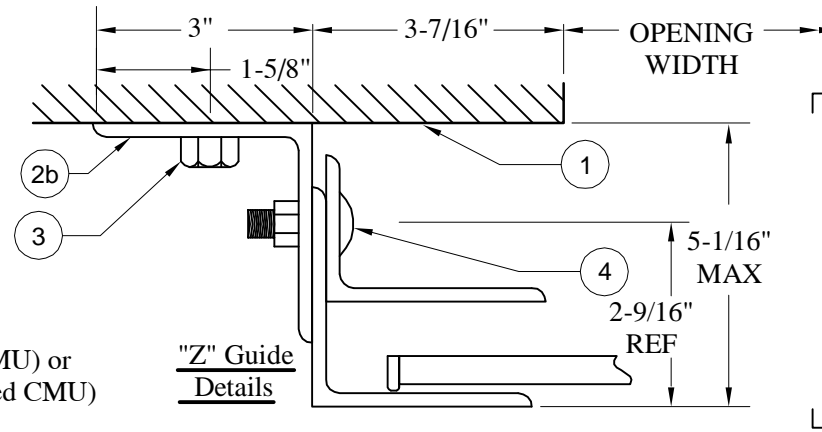
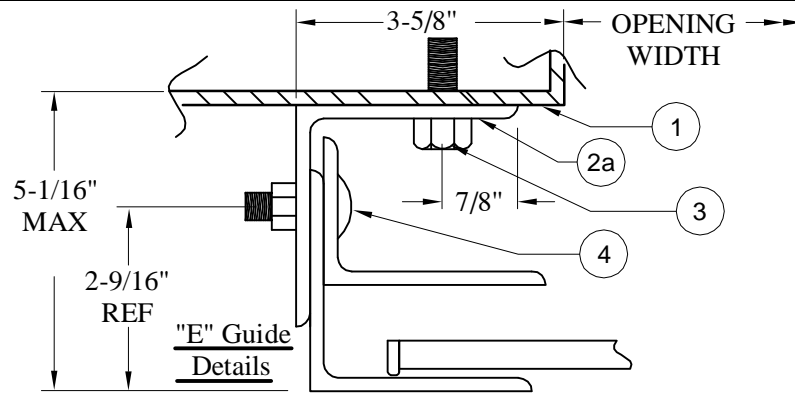

John E. Scates, P.E.
3121 Fairgate Drive
Carrollton, Texas 75007
TX P.E. # 56308 F-2203

The jambs must be designed (by others) to withstand direct forces due to wind (width x psf/2) on this door. Forces are in units of "pounds per foot tall". Direct forces due to wind occur in both (+) and (-) directions.

 <small>1485 Sunrise Drive, Arthur, IL 61911</small>	Date: 8-31-2015
	Models: 6181, 6201, 6221, 6266
14'-04" wide +20.0/-24.3psf	
C.H.I. Drawing: TZ4n-14-R1002	

Professional Engineer's seal provided only for verification of windload construction details

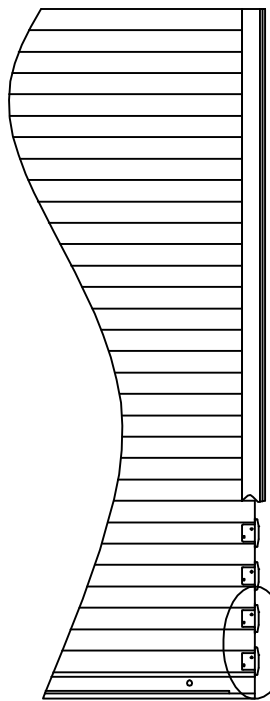

Rivet Diameter: 1/4"
 Rivet Body: Steel
 Rivet Mandrel: Steel

Rivet

Note:
 Construction of the door above the header is not part of the windload design and not detailed on this drawing.

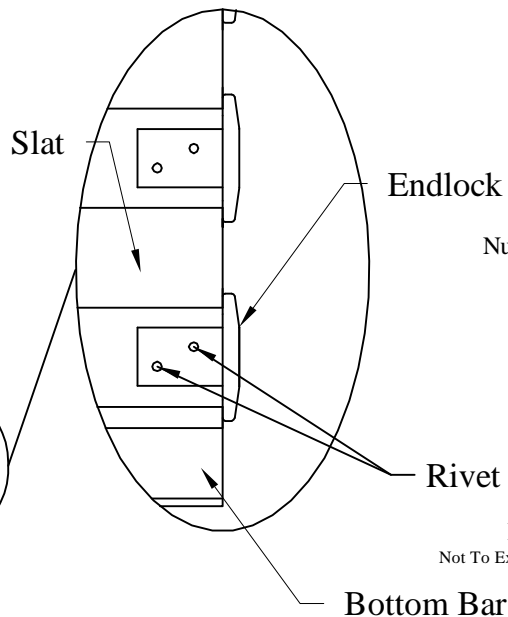

Number of fasteners
 minus 1

Opening
 Height
 + 4"

Run Out
 Not To Exceed Minimum Spacing

Bottom Bar

Opening Height	Quantity of Jamb Fasteners				
	steel	bolt through	2000psi concrete Simpson	2000psi filledCMU 5/8 Hilti	2000psi filledCMU 3/8 Hilti
8'-0"	3	5	5	7	10
9'-0"	4	5	5	7	11
10'-0"	4	5	5	8	12
11'-0"	4	6	6	9	13
12'-0"	4	6	6	9	15
13'-0"	5	7	7	10	16
14'-0"	5	7	7	11	17
15'-0"	5	7	7	12	19
16'-0"	5	8	8	12	20
17'-0"	6	8	8	13	21
18'-0"	6	9	9	14	22
20'-0"	6	9	9	15	24
22'-0"	7	10	10	17	26
24'-0"	7	11	11	18	28
Spacing not to exceed	48"	30"	30"	17"	11"

John E. Scates, P.E.
 3121 Fairgate Drive
 Carrollton, Texas 75007
 TX P.E. # 56308 F-2203

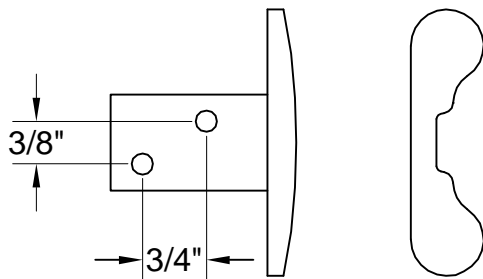

Cast Endlock

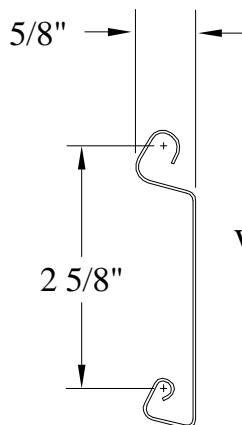

Steel Flat Slat
 .028" Thickness

Starter Slat
 5/16" x 1"
 Grade 2
 Carriage Bolt
 With Flange Nut
 Not To Exceed
 54" On Centers.

A36 Structural
 Steel Angle
 2" x 2" x 1/8"



Bottom Bar



Date: 8-31-2015

Models:
 6181, 6201, 6221, 6266

14'-04" wide +20.0/-24.3psf

C.H.I. Drawing: TZ4n-14-R1002