

THE METHOD OF TESTING WAS IN SUBSTANTIAL CONFORMANCE WITH THE PROCEDURE DESCRIBED IN ASTM E330 AND DASMA 108. THE PRESSURES SHOWN ON THE DRAWINGS WERE CALCULATED USING ASCE 7-98/02/05 WITH THE FOLLOWING PARAMETERS (5 FEET OF DOOR WIDTH IN THE END ZONE, ROOF AT ANY SLOPE, AND I=1.0):

WIND SPEED (MPH)	145	131	125	119	114
EXPOSURE LEVEL	B	C	C	D	D
MEAN ROOF HEIGHT	30'	15'	25'	15'	25'

- SPECIFICATIONS AND NOTES**
- ALL THE LOAD FROM THE DOOR IS TRANSFERRED TO THE VERTICAL TRACK. FROM THE TRACK THE LOAD IS TRANSFERRED TO THE VERTICAL JAMBS. THE HORIZONTAL JAMB OR HEADER RECEIVES NO PORTION OF THE LOAD TRANSFERRED FROM THE DOOR.
 - EACH VERTICAL JAMBS RECEIVES MAXIMUM DESIGN LOADS OF: +255.2 LBS/FT & -289.6 LBS/FT
 - DOORS AND HARDWARE WILL BE DESIGNED, MANUFACTURED AND INSTALLED WITH STANDARDS AS SET FORTH BY DASMA.
 - DOOR SECTIONS SHALL BE 25 GA. MIN. (.019") ROLLED FORMED LIGHT COMMERCIAL QUALITY
 - SUPPORTING STRUCTURAL ELEMENTS SHALL BE DESIGNED BY A REGISTERED PROFESSIONAL ENGINEER FOR WIND LOADS INDICATED ON THIS DRAWING IN ADDITION TO OTHER LOADINGS.

REV	DESCRIPTION OF REVISIONS	DATE	BY
A	UPDATED BOTTOM BRACKET INFORMATION ADDED OAKSUMMIT AND GLAZING OPTIONS	07/12/05	DLJ
B	REVISED NOTE 6	09/02/08	DLJ
C	REMOVED NOTE 7, TABLE 4.	05/20/09	CBT
D	WIND SPEED TABLE & TRACK CONFIGURATIONS	04/06/12	RLR

MAX SIZE
16' WIDTH
14' HEIGHT
(DOOR HEIGHT SUBJECT TO WEIGHT LIMITATIONS)
DESIGN LOADS
+31.9 PSF
-36.2 PSF
TEST LOADS
(1.5 x DESIGN LOADS)
+47.8 PSF
-54.3 PSF



Amarr
165 CARRIAGE COURT WINSTON-SALEM, NC. 27105

MODEL #650 OAK SUMMIT w/DuraSafe
MODEL #600 STRATFORD w/DuraSafe
MODEL #950 HERITAGE w/DuraSafe
Short, Long, Flush & Oak Summit Panel's

SIZE	DRAWN BY DLJ	DATE 12/31/03	DRAWING NUMBER IRC-6016-145-32
B	CHECKED BY AAE	DATE 12/31/03	

ENGINEER: THOMAS L. SHELMERDINE P.E. LIC. No. 0048579 SHEET 1 OF 3

WOOD JAMB ATTACHMENT TO STRUCTURE

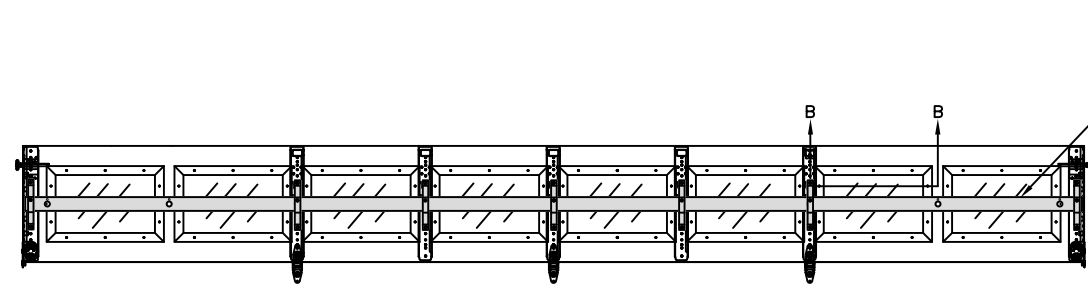

(1) 4" X 2 1/2" X 16GA C-CHANNEL ATTACHED IN THE CENTER OF SECTION WITH (1) 1/4" X 1-1/2" HEX HEAD LAG AT EACH END STILE AND (1) 1/4" X 3/4" HEX HEAD SCREW AT EACH CENTER STILE.

OPTIONAL SHORT PANEL GLAZED SECTION STRUT AND STILE LAYOUT

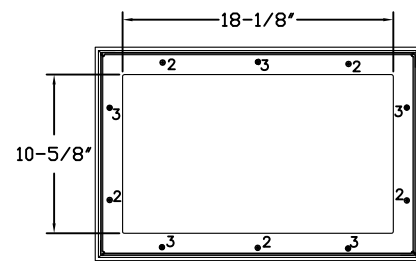

SHORT PANEL GLAZING FASTENER DETAIL
N.T.S.

GLAZING OPTION CROSS SECTION

GLAZING NOT AVAILABLE IN WIND-BORNE DEBRIS REGION
GLAZING MEETS ASTM E1300-04

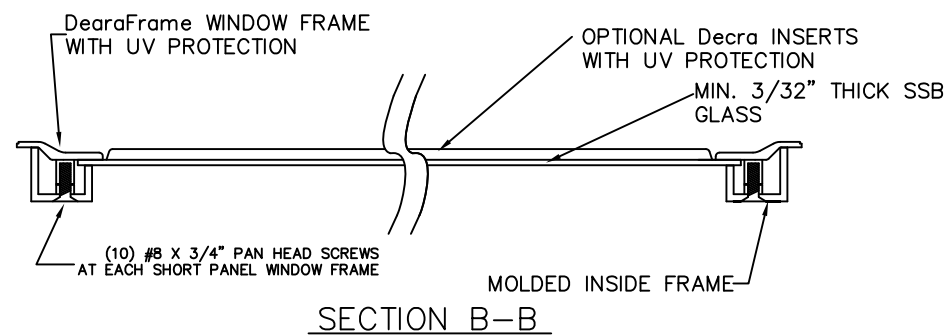

SECTION B-B

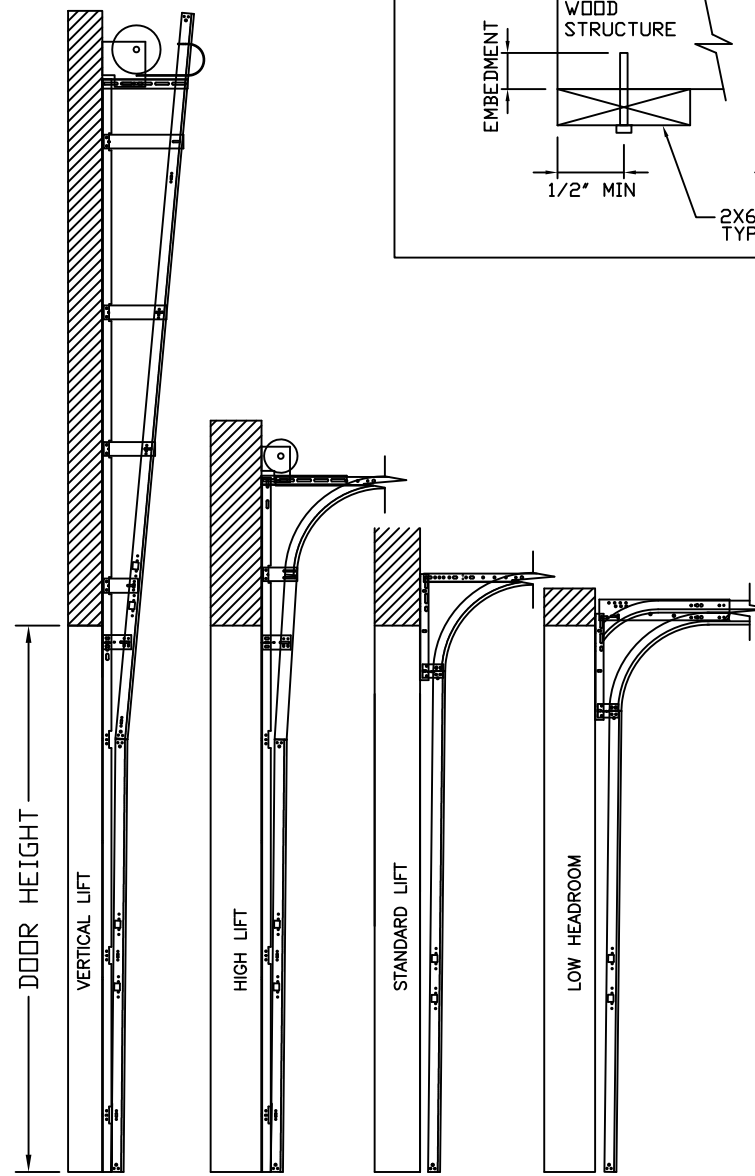

AVAILABLE TRACK CONFIGURATIONS
N.T.S.

- 2 X 6 VERTICAL JAMB ATTACHMENT TO WOOD FRAME STRUCTURE
5/16" X 3" LAG SCREWS STARTING 6" FROM ENDS THEN 18" O.C. (1 1/2" EMBEDMENT)
- 2 X 6 VERTICAL JAMB ATTACHMENT TO 2,000 PSI CONCRETE
HILTI KWIK BOLT 3/8" X 4" STARTING 6" FROM ENDS THEN 24" O.C. (2 1/2" EMBEDMENT)
HILTI SLEEVE ANCHOR 3/8" X 2-3/4" STARTING 6" FROM ENDS THEN 16" O.C. (1 1/4" EMBEDMENT)
ITW/RAMSET REDHEAD (TRU-BOLT) 3/8" X 4" STARTING 6" FROM ENDS THEN 24" O.C. (2 1/2" EMBEDMENT)
- 2 X 6 VERTICAL JAMB ATTACHMENT TO HOLLOW C-90 BLOCK
SIMPSON 1/4" X 3" TITEN SCREWS STARTING 6" FROM ENDS, USE PAIRS OF FASTENERS (3" APART) AT 8" O.C. (1 1/2" EMBEDMENT)
HILTI 1/4" X 2-3/4" KWIK-CON II+ SCREWS STARTING 6" FROM ENDS, USE PAIRS OF FASTENERS (3" APART) AT 8" O.C. (1 1/4" EMBEDMENT)
- 2 X 6 VERTICAL JAMB ATTACHMENT TO GROUTED C-90 BLOCK (2000 PSI GROUT)
HILTI SLEEVE ANCHOR 3/8" X 2-3/4" STARTING 6" FROM ENDS THEN 20" O.C. (1 1/4" EMBEDMENT) (OR, USE FASTENERS FOR HOLLOW C-90 BLOCK)

*LAGS AND BOLTS CAN BE COUNTERSUNK TO PROVIDE A FLUSH MOUNTING SURFACE.
*PREPARATION OF WOOD JAMBS BY OTHERS

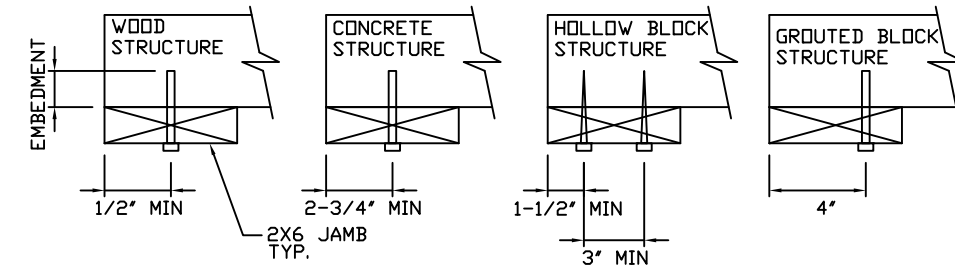

REV	DESCRIPTION OF REVISIONS	DATE	BY
A	UPDATED BOTTOM BRACKET INFORMATION ADDED OAKSUMMIT AND GLAZING OPTIONS	07/12/05	DLJ
B	REVISED NOTE 6	09/02/08	DLJ
C	REMOVED NOTE 7, TABLE 4.	05/20/09	CBT
D	WIND SPEED TABLE & TRACK CONFIGURATIONS	04/06/12	RLR

MAX SIZE
16' WIDTH
14' HEIGHT
(DOOR HEIGHT SUBJECT TO WEIGHT LIMITATIONS)
DESIGN LOADS
+31.9 PSF
-36.2 PSF
TEST LOADS (1.5 x DESIGN LOADS)
+47.8 PSF
-54.3 PSF



Amarr

165 CARRIAGE COURT WINSTON-SALEM, NC. 27105

MODEL #650 OAK SUMMIT w/DuraSafe
MODEL #600 STRATFORD w/DuraSafe
MODEL #950 HERITAGE w/DuraSafe
Short, Long, Flush & Oak Summit Panel's

SIZE	DRAWN BY	DLJ	DATE	12/31/03	DRAWING NUMBER
B	CHECKED BY	AAE	DATE	12/31/03	IRC-6016-145-32

ENGINEER: THOMAS L. SHELMERDINE P.E. LIC. No. 0048579 SHEET 2 OF 3

TABLE 1

DOOR HEIGHT	SECTION HEIGHTS							
	Btm	#2	#3	#4	#5	#6	#7	#8
14' 0"	21"	21"	21"	21"	21"	21"	21"	21"
13' 6"	21"	21"	21"	21"	21"	18"	18"	21"
13' 0"	21"	21"	21"	18"	18"	18"	18"	21"
12' 6"	21"	18"	18"	18"	18"	18"	18"	21"
12' 0"	21"	21"	21"	21"	21"	18"	21"	
11' 6"	21"	21"	21"	18"	18"	18"	21"	
11' 0"	21"	18"	18"	18"	18"	18"	21"	
10' 6"	21"	21"	21"	21"	21"	21"		
10' 0"	21"	21"	21"	18"	18"	21"		
9' 6"	21"	18"	18"	18"	18"	21"		
9' 0"	18"	18"	18"	18"	18"	18"		
8' 6"	21"	21"	21"	18"	21"			
8' 0"	21"	18"	18"	18"	21"			
7' 6"	18"	18"	18"	18"	18"			
7' 0"	21"	21"	21"	21"				
6' 6"	21"	18"	18"	21"				

TABLE 2

DOOR HEIGHT	TRACK ATTACHMENT								SPLICE
	A	B	C	D	E	F	G	H	
6' 6"	10"	21"	38"	58"					70"
7'	10"	21"	42"	63"					76"
7' 6"	10"	18"	36"	54"	72"				82"
8'	10"	21"	39"	58"	75"				88"
8' 6"	10"	21"	42"	63"	81"				94"
9'	10"	18"	36"	54"	72"	90"			100"
9' 6"	10"	21"	39"	57"	75"	93"			106"
10'	10"	21"	42"	63"	81"	99"			112"
10' 6"	10"	21"	42"	63"	84"	105"			118"
11'	10"	21"	39"	57"	75"	93"	111"		124"
11' 6"	10"	21"	42"	63"	81"	99"	117"		130"
12'	10"	21"	42"	63"	84"	105"	123"		136"
12' 6"	10"	21"	39"	57"	75"	93"	111"	129"	142"
13'	10"	21"	42"	63"	81"	99"	117"	135"	148"
13' 6"	10"	21"	42"	63"	84"	105"	123"	141"	154"
14'	10"	21"	42"	63"	84"	105"	126"	147"	160"

TABLE 3

Section Width (ft)	Panel Type	Center Stile Locations (Measured from Left Edge)				
		1st (in)	2nd (in)	3rd (in)	4th (in)	5th (in)
10' 0"	Short	48.41	71.59			
10' 0"	Long	30.00	60.00	90.00		
10' 0"	Oak Summit	30.63	60.00	89.38		
12' 0"	Short	48.81	72.00	95.19		
12' 0"	Long	49.63	72.00	94.38		
12' 0"	Oak Summit	48.31	72.00	95.69		
12' 2"	Short	49.64	73.00	96.36		
12' 2"	Long	50.08	73.00	95.92		
12' 2"	Oak Summit	49.06	73.00	96.94		
12' 4"	Short	50.64	74.00	97.36		
12' 4"	Long	51.08	74.00	96.92		
12' 4"	Oak Summit	49.81	74.00	98.19		
12' 6"	Short	50.67	75.00	99.33		
12' 6"	Long	51.17	75.00	98.83		
12' 6"	Oak Summit	50.56	75.00	99.44		
12' 8"	Short	51.67	76.00	100.33		
12' 8"	Long	52.10	76.00	99.90		
12' 8"	Oak Summit	51.31	76.00	100.69		
12' 10"	Short	52.25	77.00	101.75		
12' 10"	Long	53.10	77.00	100.90		
12' 10"	Oak Summit	52.06	77.00	101.94		
13' 0"	Short	53.00	78.00	103.00		
13' 0"	Long	54.10	78.00	101.90		
13' 0"	Oak Summit	52.81	78.00	103.19		
13' 2"	Short	54.00	79.00	104.00		
13' 2"	Long	55.10	79.00	102.90		
13' 2"	Oak Summit	53.56	79.00	104.44		
13' 4"	Short	54.40	80.00	105.60		
13' 4"	Long	54.90	80.00	105.10		
13' 4"	Oak Summit	54.31	80.00	105.69		
13' 6"	Short	55.40	81.00	106.60		
13' 6"	Long	55.90	81.00	106.10		
13' 6"	Oak Summit	55.06	81.00	106.94		
13' 8"	Short	56.40	82.00	107.60		
13' 8"	Long	56.63	82.00	107.38		
13' 8"	Oak Summit	55.81	82.00	108.19		
13' 10"	Short	57.16	83.00	108.71		
13' 10"	Long	57.17	83.00	108.83		
13' 10"	Oak Summit	56.56	83.00	109.44		
14' 0"	Short	57.76	84.00	110.11		
14' 0"	Long	58.63	84.00	109.38		
14' 0"	Oak Summit	57.31	84.00	110.69		
14' 2"	Short	58.85	85.00	111.41		
14' 2"	Long	59.17	85.00	110.83		
14' 2"	Oak Summit	58.06	85.00	111.94		
14' 4"	Short	59.16	86.00	112.71		
14' 4"	Long	60.17	86.00	111.83		
14' 4"	Oak Summit	58.81	86.00	113.19		
14' 6"	Short	59.86	87.00	114.01		
14' 6"	Long	61.17	87.00	112.83		
14' 6"	Oak Summit	59.56	87.00	114.44		
14' 8"	Short	60.56	88.00	115.31		
14' 8"	Long	64.81	88.00	109.59	131.19	
14' 8"	Oak Summit	60.31	88.00	115.69		
14' 10"	Short	61.26	89.00	116.61		
14' 10"	Long	65.60	89.00	110.70	132.40	
14' 10"	Oak Summit	61.06	89.00	116.94		
15' 0"	Short	61.94	90.00	117.97	117.94	
15' 0"	Long	66.60	90.00	111.70	133.40	
15' 0"	Oak Summit	63.63	90.00	118.19	146.38	
15' 2"	Short	62.66	91.00	118.83	119.21	
15' 2"	Long	67.60	91.00	112.70	134.40	
15' 2"	Oak Summit	64.13	91.00	119.44	147.88	
15' 4"	Short	63.60	92.00	120.40	130.40	
15' 4"	Long	68.25	92.00	114.38	136.75	
15' 4"	Oak Summit	65.63	92.00	120.69	149.38	
15' 6"	Short	64.62	93.00	121.19	139.38	
15' 6"	Long	69.60	93.00	115.70	138.40	
15' 6"	Oak Summit	67.42	93.00	121.79	138.58	
15' 8"	Short	65.62	94.00	122.19	140.38	
15' 8"	Long	70.60	94.00	116.70	139.40	
15' 8"	Oak Summit	68.02	94.00	122.99	139.98	
15' 10"	Short	66.62	95.00	123.19	141.38	
15' 10"	Long	71.17	95.00	117.92	140.83	
15' 10"	Oak Summit	69.62	95.00	123.19	141.38	
16' 0"	Short	67.62	96.00	123.19	142.38	
16' 0"	Long	72.60	96.00	118.70	141.40	
16' 0"	Oak Summit	70.42	96.00	123.79	143.58	

^ Stiles do not need to be hinged

TABLE 4

Section Width (ft)	Panel Type	Max Design Loads Allowed	
		Positive (PSF)	Negative (PSF)
10' 0"	Short	42.6	48.3
10' 0"	Long	50.8	57.6
10' 0"	Oak Summit	50.8	57.6
12' 0"	Short	42.3	48.0
12' 0"	Long	42.3	48.0
12' 0"	Oak Summit	42.3	48.0
12' 2"	Short	41.7	47.4
12' 2"	Long	41.7	47.4
12' 2"	Oak Summit	41.7	47.4
12' 4"	Short	41.2	46.7
12' 4"	Long	41.2	46.7
12' 4"	Oak Summit	41.2	46.7
12' 6"	Short	40.6	46.1
12' 6"	Long	40.6	46.1
12' 6"	Oak Summit	40.6	46.1
12' 8"	Short	40.1	45.5
12' 8"	Long	40.1	45.5
12' 8"	Oak Summit	40.1	45.5
12' 10"	Short	39.6	44.9
12' 10"	Long	39.6	44.9
12' 10"	Oak Summit	39.6	44.9
13' 0"	Short	39.1	44.3
13' 0"	Long	39.1	44.3
13' 0"	Oak Summit	39.1	44.3
13' 2"	Short	38.6	43.8
13' 2"	Long	38.6	43.8
13' 2"	Oak Summit	38.6	43.8
13' 4"	Short	38.1	43.2
13' 4"	Long	38.1	43.2
13' 4"	Oak Summit	38.1	43.2
13' 6"	Short	37.6	42.7
13' 6"	Long	37.6	42.7
13' 6"	Oak Summit	37.6	42.7
13' 8"	Short	37.2	42.2
13' 8"	Long	37.2	42.2
13' 8"	Oak Summit	37.2	42.2
13' 10"	Short	36.7	41.7
13' 10"	Long	36.7	41.7
13' 10"	Oak Summit	36.7	41.7
14' 0"	Short	36.3	41.2
14' 0"	Long	36.3	41.2
14' 0"	Oak Summit	36.3	41.2
14' 2"	Short	35.8	40.7
14' 2"	Long	35.8	40.7
14' 2"	Oak Summit	35.8	40.7
14' 4"	Short	35.4	40.2
14' 4"	Long	35.4	40.2
14' 4"	Oak Summit	35.4	40.2
14' 6"	Short	35.0	39.7
14' 6"	Long	35.0	39.7
14' 6"	Oak Summit	35.0	39.7
14' 8"	Short	34.6	39.3
14' 8"	Long	34.6	39.3
14' 8"	Oak Summit	34.6	39.3
14' 10"	Short	34.2	38.9
14' 10"	Long	34.2	38.9
14' 10"	Oak Summit	34.2	38.9
15' 0"	Short	33.9	38.4
15' 0"	Long	33.9	38.4
15' 0"	Oak Summit	33.9	38.4
15' 2"	Short	33.5	38.0
15' 2"	Long	33.5	38.0
15' 2"	Oak Summit	33.5	38.0
15' 4"	Short	33.1	37.6
15' 4"	Long	33.1	37.6
15' 4"	Oak Summit	33.1	37.6
15' 6"	Short	32.8	37.2
15' 6"	Long	32.8	37.2
15' 6"	Oak Summit	32.8	37.2
15' 8"	Short	32.4	36.8
15' 8"	Long	32.4	36.8
15' 8"	Oak Summit	32.4	36.8
15' 10"	Short	32.1	36.4
15' 10"	Long	32.1	36.4
15' 10"	Oak Summit	32.1	36.4
16' 0"	Short	31.9	36.2
16' 0"	Long	31.9	36.2
16' 0"	Oak Summit	31.9	36.2

REV	DESCRIPTION OF REVISIONS	DATE	BY
A	UPDATED BOTTOM BRACKET INFORMATION ADDED OAKSUMMIT AND GLAZING OPTIONS	07/12/05	DLJ
B	REVISED NOTE 6	09/02/08	DLJ
C	REMOVED NOTE 7, TABLE 4.	05/20/09	CBT
D	WIND SPEED TABLE & TRACK CONFIGURATIONS	04/06/12	RLR

MAX SIZE
16' WIDTH
14' HEIGHT
(DOOR HEIGHT
SUBJECT TO
WEIGHT LIMITATIONS)
DESIGN LOADS
+31.9 PSF
-36.2 PSF
TEST LOADS
(1.5 x DESIGN LOADS)
+47.8 PSF
-54.3 PSF



165 CARRIAGE COURT WINSTON-SALEM, NC. 27105

MODEL #650 OAK SUMMIT w/DuraSafe
MODEL #600 STRATFORD w/DuraSafe
MODEL #950 HERITAGE w/DuraSafe
Short, Long, Flush & Oak Summit Panel's

SIZE	DRAWN BY	DLJ	DATE	12/31/03	DRAWING NUMBER
	B	CHECKED BY	AAE	DATE	

ENGINEER: THOMAS L. SHELME RDINE P.E. LIC. No. 0048579 SHEET 3 OF 3