

TYPICAL TOP FIXTURES
N.T.S.

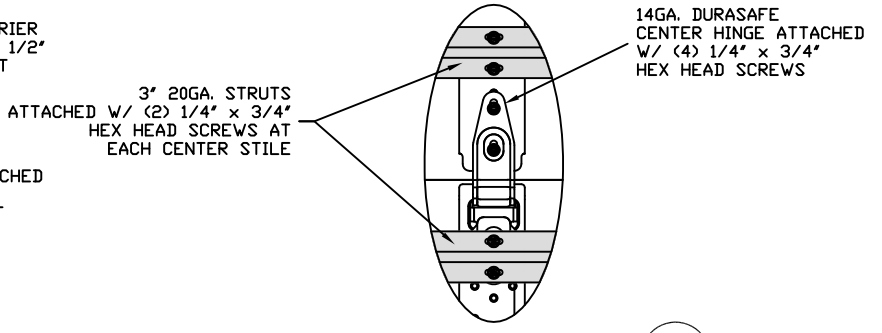

TYPICAL DURASAFE CENTER HINGE
N.T.S.

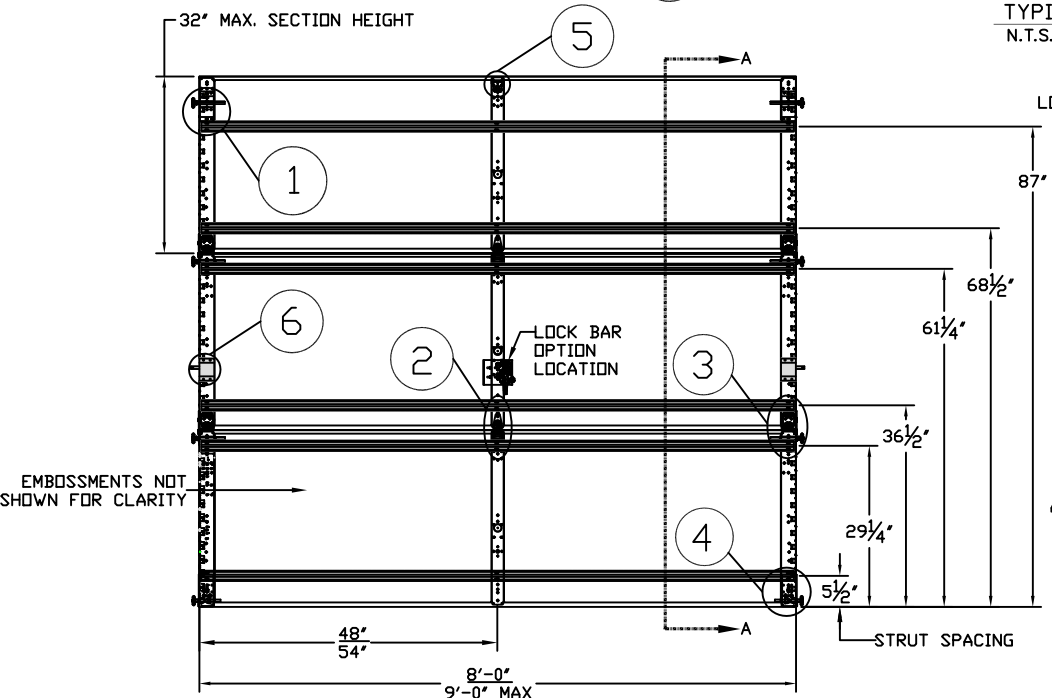

INSIDE ELEVATION
N.T.S.

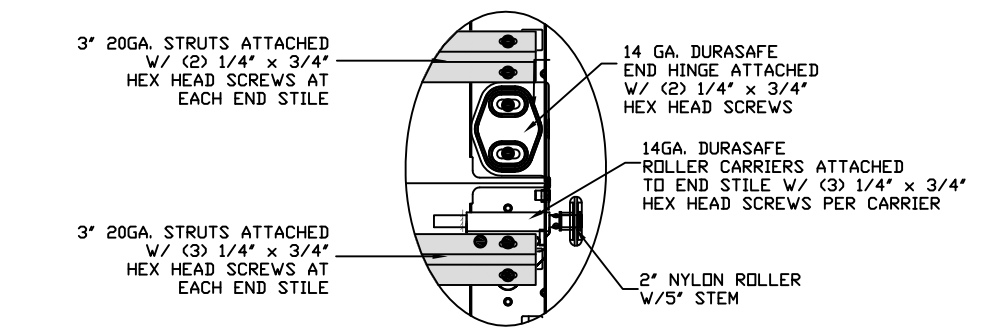

DURASAFE END HINGE
N.T.S.

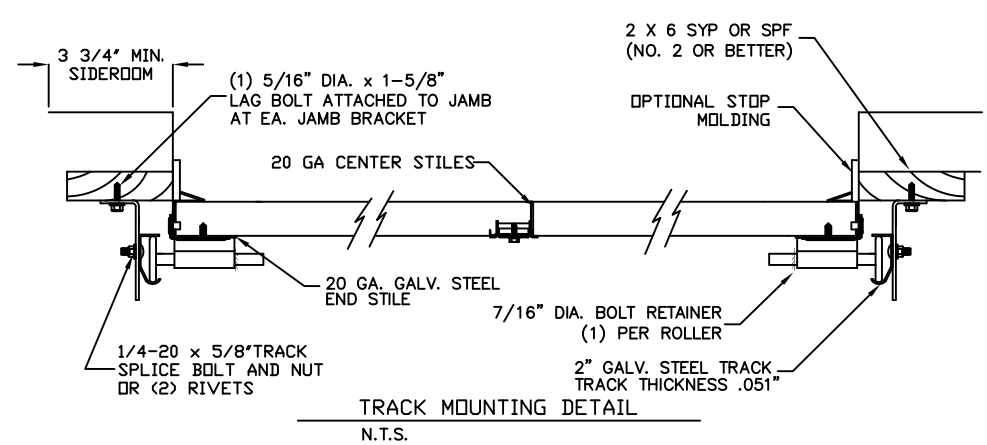

TRACK MOUNTING DETAIL
N.T.S.

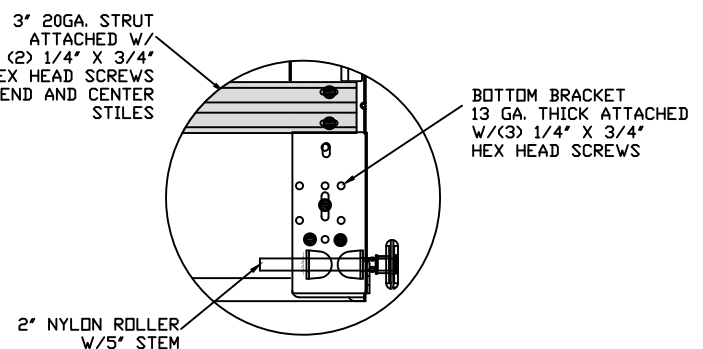

TYPICAL BOTTOM BRACKET
N.T.S.

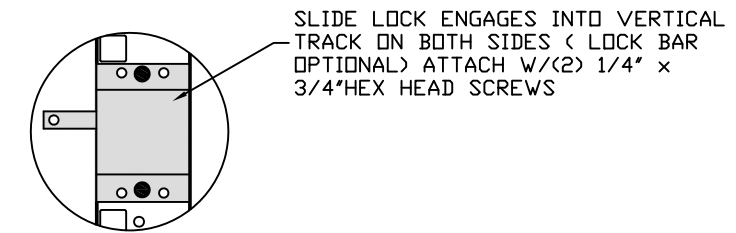

SLIDE LOCK
N.T.S.

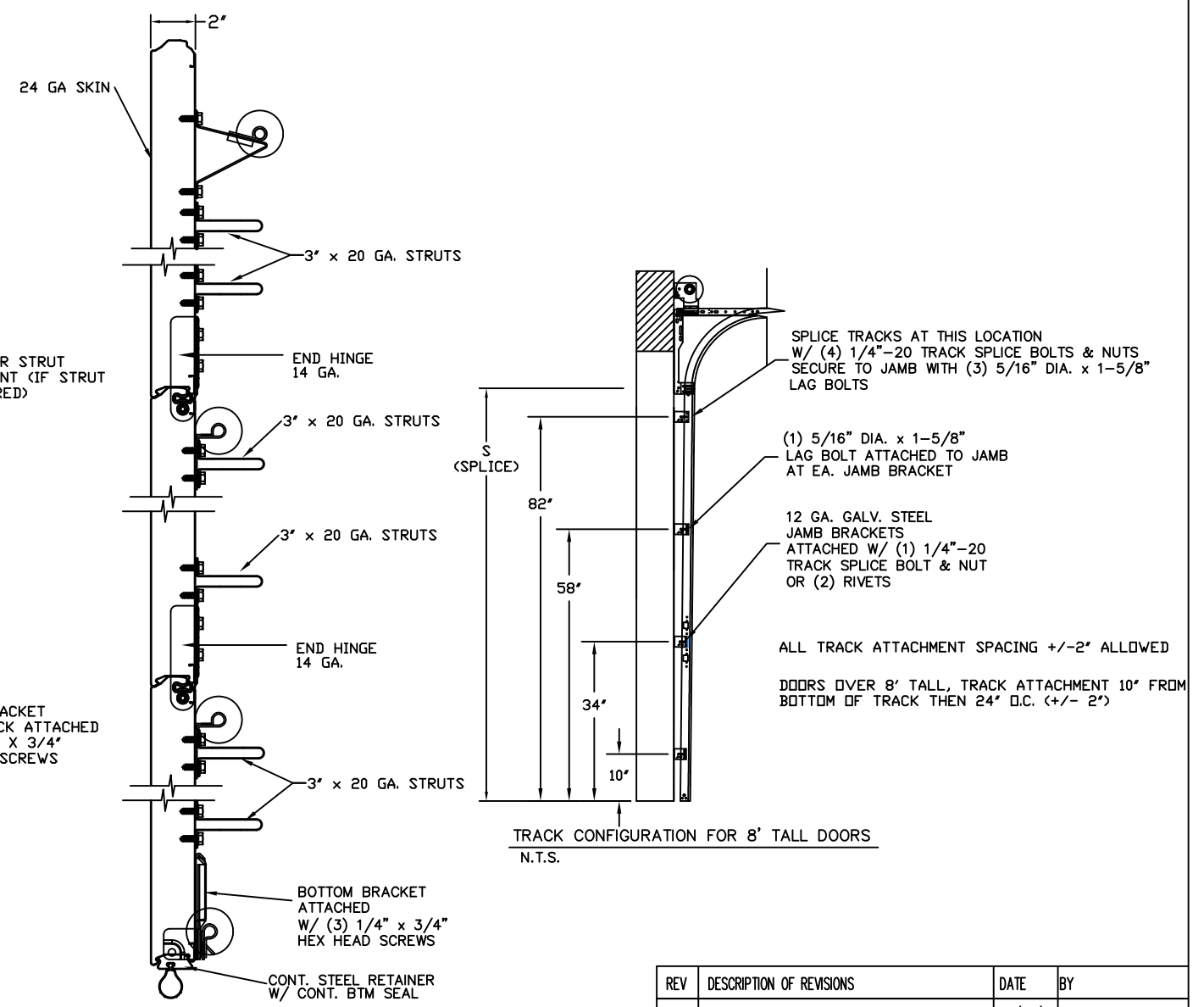

SECTION A-A (SIDE VIEW)
N.T.S.

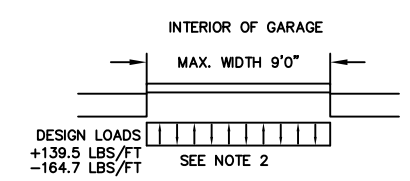

SPECIFICATIONS AND NOTES

- ALL THE LOAD FROM THE DOOR IS TRANSFERRED TO THE VERTICAL TRACK, FROM THE TRACK THE LOAD IS TRANSFERRED TO THE VERTICAL JAMBS. THE HORIZONTAL JAMB OR HEADER RECEIVES NO PORTION OF THE LOAD TRANSFERRED FROM THE DOOR.
- EACH VERTICAL JAMB RECEIVES MAXIMUM DESIGN LOADS OF: +139.5 LBS/FT & -164.7 LBS/FT
- DOORS AND HARDWARE WILL BE DESIGNED, MANUFACTURED AND INSTALLED WITH STANDARDS AS SET FORTH BY DASMA.
- DOOR SECTIONS SHALL BE 24 GA. MIN. (.022") ROLLED FORMED LIGHT COMMERCIAL QUALITY
- SUPPORTING STRUCTURAL ELEMENTS SHALL BE DESIGNED BY A REGISTERED PROFESSIONAL ENGINEER FOR WIND LOADS INDICATED ON THIS DRAWING IN ADDITION TO OTHER LOADINGS.

THE METHOD OF TESTING WAS IN SUBSTANTIAL CONFORMANCE WITH THE PROCEDURE DESCRIBED IN ASTM E330 AND DASMA 108. THE PRESSURES SHOWN ON THE DRAWINGS WERE CALCULATED USING ASCE 7-98/02/05 WITH THE FOLLOWING PARAMETERS (5 FEET OF DOOR WIDTH IN THE END ZONE, ROOF AT ANY SLOPE, AND I=1.0):

WIND SPEED (MPH)	140	127	120	115	110
EXPOSURE LEVEL	B	C	C	D	D
MEAN ROOF HEIGHT	30'	15'	25'	15'	25'

REV	DESCRIPTION OF REVISIONS	DATE	BY
A	WIND SPEED TABLE & TRACK CONFIGURATIONS	04/24/12	RLR

MAX SIZE
9' x 14'

DESIGN LOADS
+31.0 PSF
-36.6 PSF

TEST LOADS
(1.5 x DESIGN LOADS)
+46.5 PSF
-55.0 PSF



Amarr

165 CARRIAGE COURT WINSTON-SALEM, N.C. 27105

MODEL #500 CLASSICA

SIZE	DRAWN BY	DLJ	DATE	05/18/04	DRAWING NUMBER	IRC-5309-140-15
B	CHECKED BY	AAE	DATE	05/18/04		

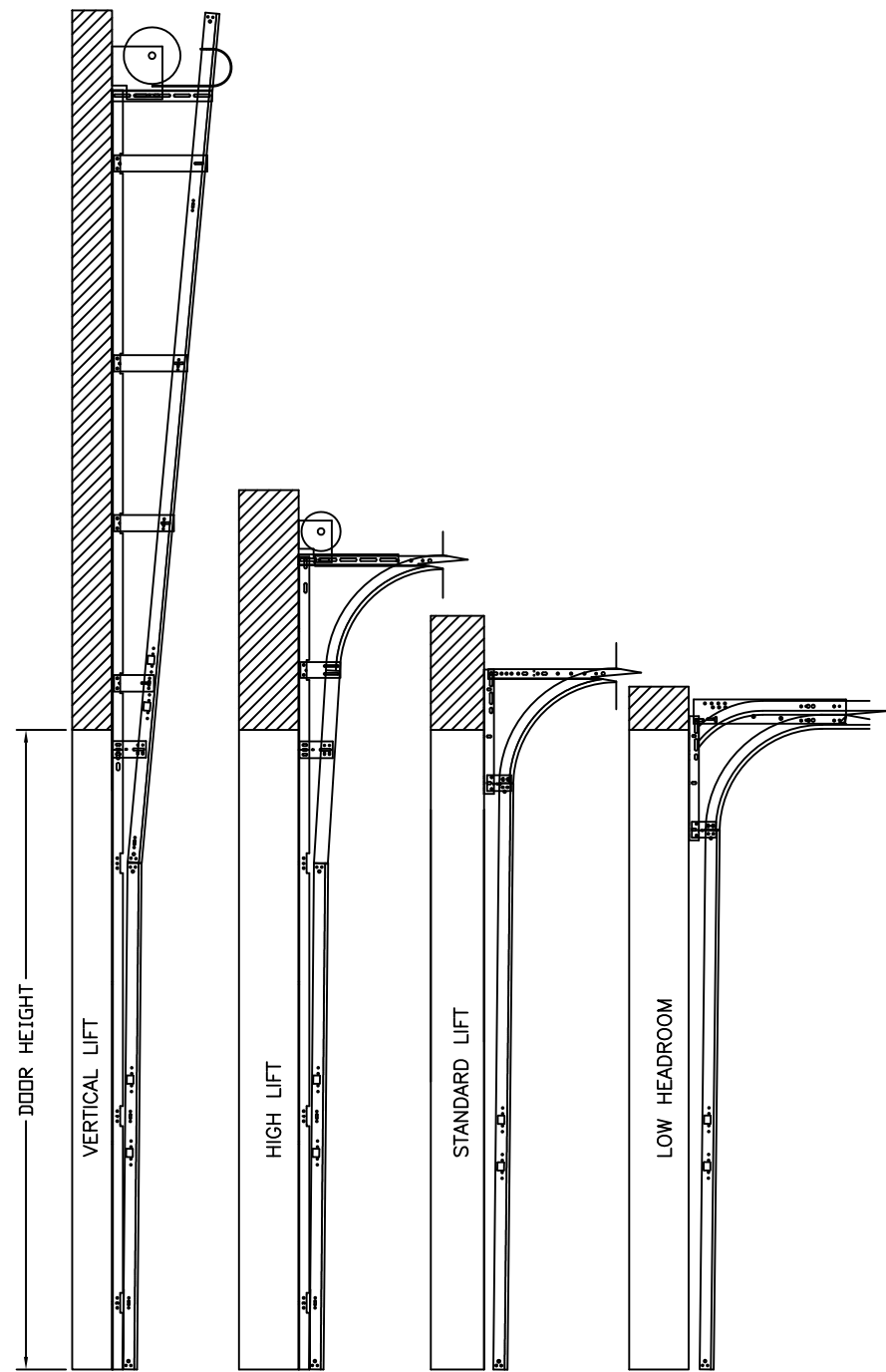

AVAILABLE TRACK CONFIGURATIONS
N.T.S.

Section Width (ft)	Center Stile Location (Measured from Left)		Max Design Loads Allowed	
	1st (in)	2st (in)	Positive (PSF)	Negative (PSF)
6' 0	24.644	47.3565	46.3	54.6
7' 0	29.144	54.857	39.7	46.8
7' 2	29.894	56.107	38.7	45.7
7' 4	30.644	57.357	37.9	44.7
7' 6	45.000		37.0	43.7
7' 8	46.000		36.2	42.8
7' 10	47.000		35.4	41.8
8' 0	48.000		34.7	41.0
8' 2	49.000		34.0	40.1
8' 4	50.000		33.3	39.3
8' 6	51.000		32.7	38.6
8' 8	52.000		32.0	37.8
8' 10	53.000		31.4	37.1
9' 0	54.000		31.0	36.6

WOOD JAMB ATTACHMENT TO STRUCTURE

2 X 6 VERTICAL JAMB ATTACHMENT TO WOOD FRAME STRUCTURE
 5/16" X 3" LAG SCREWS STARTING 6" FROM ENDS THEN 24" O.C. (1 1/2" EMBEDMENT)
2 X 6 VERTICAL JAMB ATTACHMENT TO 2,000 PSI CONCRETE
 HILTI KWIK BOLT 3/8" X 4" STARTING 6" FROM ENDS THEN 24" O.C. (2 1/2" EMBEDMENT)
 HILTI SLEEVE ANCHOR 3/8" X 2-3/4" STARTING 6" FROM ENDS THEN 24" O.C. (1 1/4" EMBEDMENT)
 ITW/RAMSET REDHEAD (TRU-BOLT) 3/8" X 4" STARTING 6" FROM ENDS THEN 24" O.C. (2 1/2" EMBEDMENT)
2 X 6 VERTICAL JAMB ATTACHMENT TO HOLLOW C-90 BLOCK
 SIMPSON 1/4" X 3" TITEN SCREWS STARTING 6" FROM ENDS, USE PAIRS OF FASTENERS (3" APART) AT 24" O.C. (1 1/2" EMBEDMENT)
 HILTI 1/4" X 2-3/4" KWIK-CON II+ SCREWS STARTING 6" FROM ENDS, USE PAIRS OF FASTENERS (3" APART) AT 24" O.C. (1 1/4" EMBEDMENT)

2 X 6 VERTICAL JAMB ATTACHMENT TO GROUTED C-90 BLOCK (2000 PSI GROUT)
 HILTI SLEEVE ANCHOR 3/8" X 2-3/4" STARTING 6" FROM ENDS THEN 24" O.C. (1 1/4" EMBEDMENT) (OR, USE FASTENERS FOR HOLLOW C-90 BLOCK)

*LAGS AND BOLTS CAN BE COUNTERSUNK TO PROVIDE A FLUSH MOUNTING SURFACE.
 *PREPARATION OF WOOD JAMBS BY OTHERS

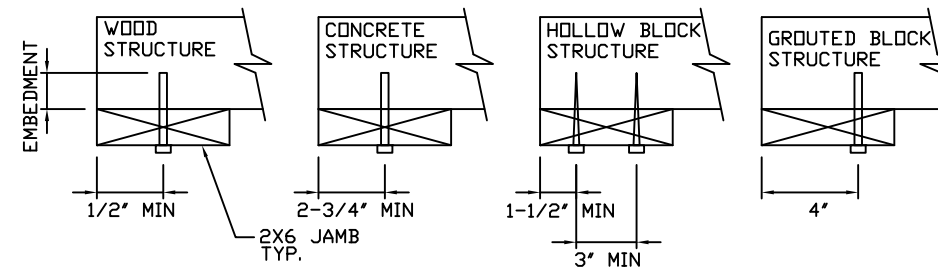

REV	DESCRIPTION OF REVISIONS	DATE	BY
A	WIND SPEED TABLE & TRACK CONFIGURATIONS	04/24/12	RLR

MAX SIZE
9' x 14'
DESIGN LOADS
+31.0 PSF
-36.6 PSF
TEST LOADS
(1.5 x DESIGN LOADS)
+46.5 PSF
-55.0 PSF



Amarr

165 CARRIAGE COURT WINSTON-SALEM, N.C. 27105

MODEL #500
CLASSICA 1000, 2000

SIZE	DRAWN BY	DLJ	DATE	05/18/04	DRAWING NUMBER
B	CHECKED BY	AAE	DATE	05/18/04	IRC-5309-140-15
ENGINEER: THOMAS L. SHELMERDINE P.E. LIC. No. 0048579					SHEET 2 OF 2