

SPECIFICATIONS AND NOTES

- DOORS AND HARDWARE WILL BE DESIGNED, MANUFACTURED AND INSTALLED WITH STANDARDS AS SET FORTH BY DASMA. EACH VERTICAL JAMBS RECEIVES MAXIMUM DESIGN LOADS OF: +194.4 LBS/FT & -220.5 LBS/FT
- DOOR SECTIONS SHALL BE 27 GA. MIN. (.0151") ROLLED FORMED LIGHT COMMERCIAL QUALITY
- SUPPORTING STRUCTURAL ELEMENTS SHALL BE DESIGNED BY A REGISTERED PROFESSIONAL ENGINEER FOR WIND LOADS INDICATED ON THIS DRAWING IN ADDITION TO OTHER LOADINGS.

THE METHOD OF TESTING WAS IN SUBSTANTIAL CONFORMANCE WITH THE PROCEDURE DESCRIBED IN DASMA 108. THE PRESSURES SHOWN ON THE DRAWINGS WERE CALCULATED USING ASCE 7-98/02/05 WITH THE FOLLOWING PARAMETERS (5 FEET OF DOOR WIDTH IN THE END ZONE, ROOF AT ANY SLOPE, AND I=1.0):

WIND SPEED (MPH)	120	109	104	99	95
EXPOSURE LEVEL	B	C	C	D	D
MEAN ROOF HEIGHT	30'	15'	25'	15'	25'

REV	DESCRIPTION OF REVISIONS	DATE	BY

MAX SIZE 18' WIDTH 14' HEIGHT (DOOR HEIGHT SUBJECT TO WEIGHT LIMITATIONS)

DESIGN LOADS +21.6 PSF -24.5 PSF

TEST LOADS (1.5 x DESIGN LOADS) +32.4 PSF -36.8 PSF

Thomas L. Shelmerdine, PE (TX PE #85829) Structural Solutions, PA (TX Firm #F-004063)

STATE OF TEXAS
THOMAS L. SHELMERDINE
85829
LICENSED PROFESSIONAL ENGINEER
TX

5921-G W. Friendly Ave., Greensboro, NC 27410

Amarr

165 CARRIAGE COURT WINSTON-SALEM, N.C. 27105 WWW.AMARR.COM

MODEL #1500 STRATFORD 3000
MODEL #1200 HERITAGE 3000
MODEL #1550 OAK SUMMIT 3000
SHORT, LONG, FLUSH & OAK SUMMIT PANELS

SIZE	DRAWN BY	RLR	DATE	11/24/13	DRAWING NUMBER
B	CHECKED BY		DATE		IRC-1518-120-24

SHEET 1 OF 3

OPTIONAL SHORT AND LONG PANEL GLAZING LAYOUTS
GLAZING MEETS ASTM E1300-04

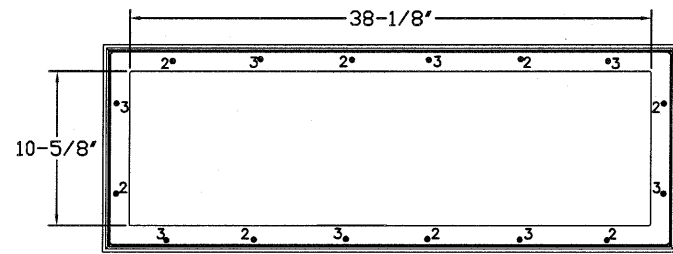
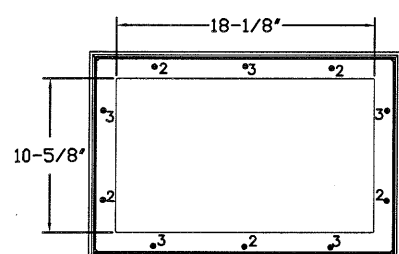
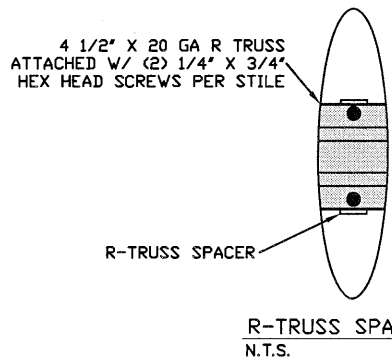
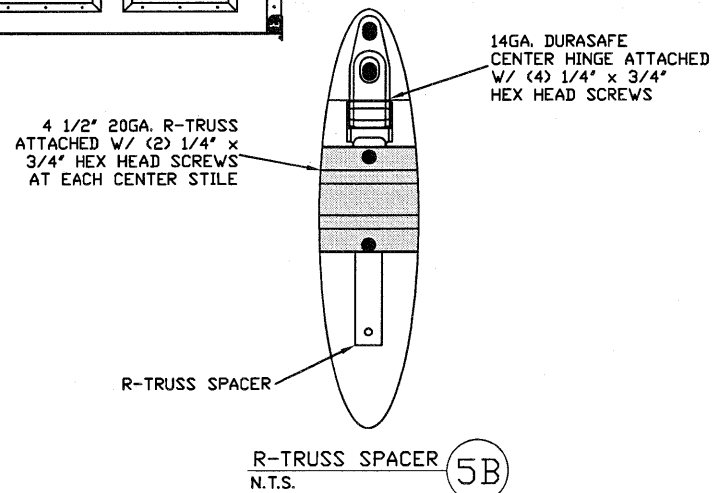
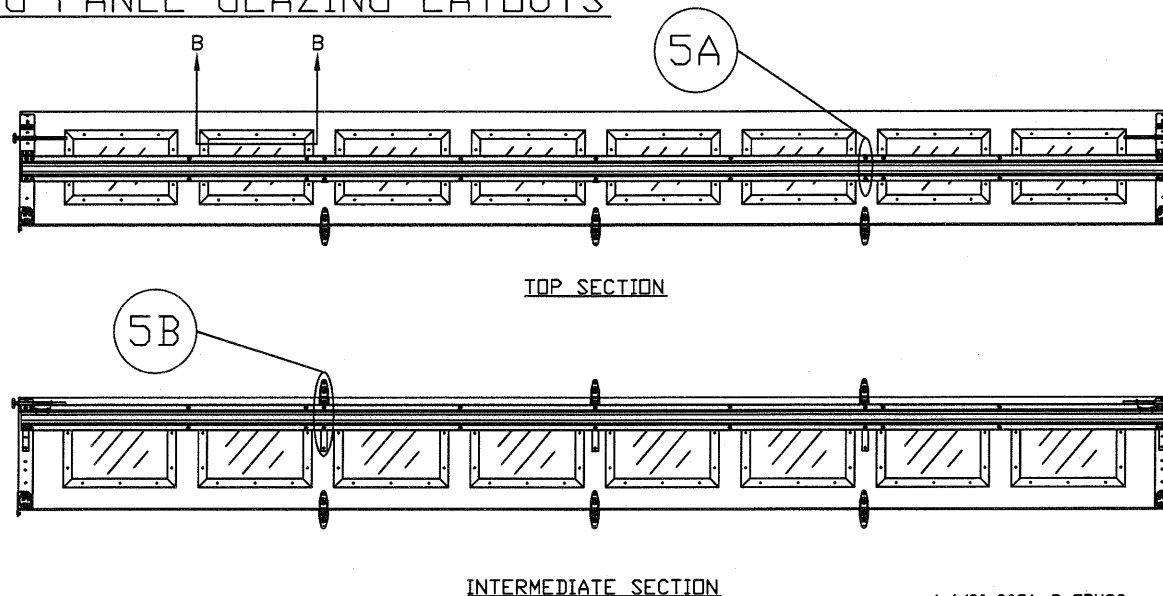
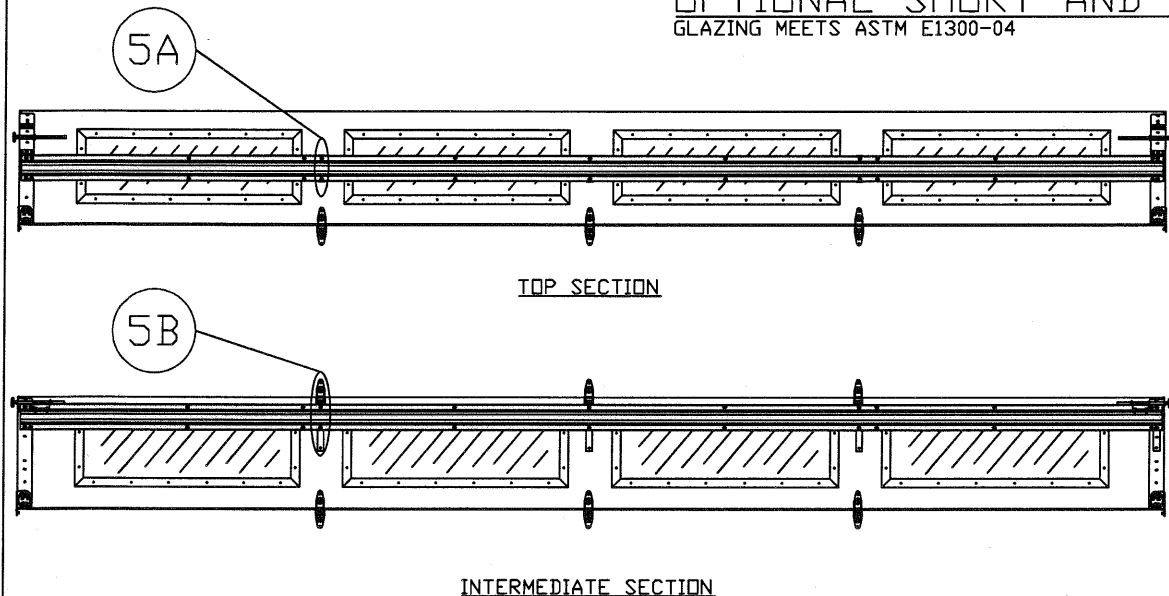

WOOD JAMB ATTACHMENT TO STRUCTURE

2 X 6 VERTICAL JAMB ATTACHMENT TO WOOD FRAME STRUCTURE
5/16" X 3" LAG SCREWS STARTING 6" FROM ENDS THEN 24" O.C. (1 1/2" EMBEDMENT)

2 X 6 VERTICAL JAMB ATTACHMENT TO 2,000 PSI CONCRETE
HILTI KWIK BOLT 3/8" X 4" STARTING 6" FROM ENDS THEN 24" O.C. (2 1/2" EMBEDMENT)
HILTI SLEEVE ANCHOR 3/8" X 2-3/4" STARTING 6" FROM ENDS THEN 22" O.C. (1 1/4" EMBEDMENT)
ITW/RAMSET REDHEAD (TRU-BOLT) 3/8" X 4" STARTING 6" FROM ENDS THEN 24" O.C. (2 1/2" EMBEDMENT)

2 X 6 VERTICAL JAMB ATTACHMENT TO HOLLOW C-90 BLOCK
SIMPSON 1/4" X 3" TITEN SCREWS STARTING 6" FROM ENDS, USE PAIRS OF FASTENERS (3" APART) AT 16" O.C. (1 1/2" EMBEDMENT)
HILTI 1/4" X 2-3/4" KWIK-CON II+ SCREWS STARTING 6" FROM ENDS, USE PAIRS OF FASTENERS (3" APART) AT 16" O.C. (1 1/4" EMBEDMENT)

2 X 6 VERTICAL JAMB ATTACHMENT TO GROUTED C-90 BLOCK (2000 PSI GROUT)
HILTI SLEEVE ANCHOR 3/8" X 2-3/4" STARTING 6" FROM ENDS THEN 24" O.C. (1 1/4" EMBEDMENT) (OR, USE FASTENERS FOR HOLLOW C-90 BLOCK)

*LAGS AND BOLTS CAN BE COUNTERSUNK TO PROVIDE A FLUSH MOUNTING SURFACE.
*PREPARATION OF WOOD JAMBS BY OTHERS

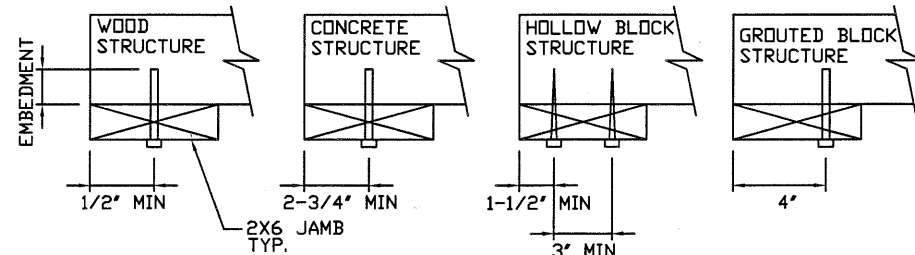

GLAZING OPTION CROSS SECTION

GLAZING NOT AVAILABLE IN WIND-BORNE DEBRIS REGION
GLAZING IS AVAILABLE FOR ANY DOOR SIZE IF THE REQUIRED DESIGN PRESSURES ARE LESS THAN OR EQUAL TO (+21.6/-24.5)

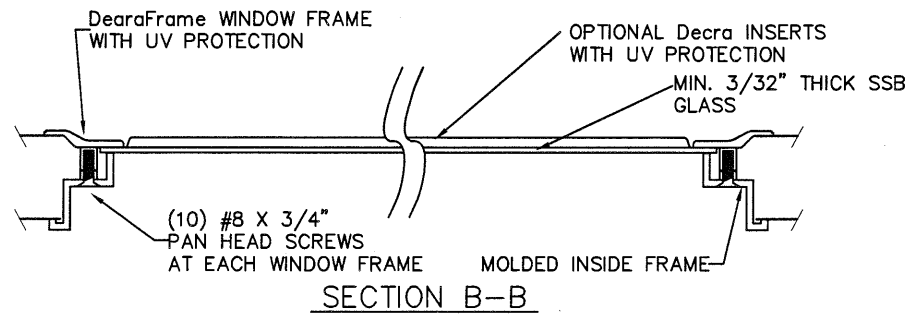

REV	DESCRIPTION OF REVISIONS	DATE	BY

MAX SIZE
18' WIDTH
14' HEIGHT
(DOOR HEIGHT SUBJECT TO WEIGHT LIMITATIONS)

DESIGN LOADS
+21.6 PSF
-24.5 PSF

TEST LOADS
(1.5 x DESIGN LOADS)
+32.4 PSF
-36.8 PSF

Thomas L. Shelmerdine, PE (TX PE #85829)
Structural Solutions, PA (TX Firm #F-004063)

STATE OF TEXAS
THOMAS L. SHELME RDINE
85829
LICENSED PROFESSIONAL ENGINEER
TX

165 CARRIAGE COURT WINSTON-SALEM, N.C. 27105 WWW.AMARR.COM

MODEL #1500 STRATFORD 3000
MODEL #1200 HERITAGE 3000
MODEL #1550 OAK SUMMIT 3000
SHORT, LONG, FLUSH & OAK SUMMIT PANELS

SIZE	DRAWN BY	RLR	DATE	11/24/13	DRAWING NUMBER
B	CHECKED BY		DATE		IRC-1518-120-24

SHEET 2 OF 3

5921-G W. Friendly Ave., Greensboro, NC 27410

TABLE 1

DOOR HEIGHT	SECTION HEIGHTS							
	Btm	#2	#3	#4	#5	#6	#7	#8
14' 0"	21"	21"	21"	21"	21"	21"	21"	21"
13' 6"	21"	21"	21"	21"	21"	18"	18"	21"
13' 0"	21"	21"	21"	18"	18"	18"	18"	21"
12' 6"	21"	18"	18"	18"	18"	18"	18"	21"
12' 0"	21"	21"	21"	21"	21"	18"	21"	
11' 6"	21"	21"	21"	18"	18"	18"	21"	
11' 0"	21"	18"	18"	18"	18"	18"	21"	
10' 6"	21"	21"	21"	21"	21"	21"		
10' 0"	21"	21"	21"	18"	18"	21"		
9' 6"	21"	18"	18"	18"	18"	21"		
9' 0"	18"	18"	18"	18"	18"	18"		
8' 6"	21"	21"	21"	18"	21"			
8' 0"	21"	18"	18"	18"	21"			
7' 6"	18"	18"	18"	18"	18"			
7' 0"	21"	21"	21"	21"				
6' 6"	21"	18"	18"	21"				

TABLE 2

DOOR HEIGHT	TRACK ATTACHMENT								SPlice
	A	B	C	D	E	F	G	H	
6' 6"	10"	21"	42"	63"					70"
7'	10"	21"	42"	63"					76"
7' 6"	10"	21"	42"	63"					82"
8'	10"	21"	42"	63"					88"
8' 6"	10"	21"	42"	63"	84"				94"
9'	10"	21"	42"	63"	84"				100"
9' 6"	10"	21"	42"	63"	84"				106"
10'	10"	21"	42"	63"	84"	105"			112"
10' 6"	10"	21"	42"	63"	84"	105"			118"
11'	10"	21"	42"	63"	84"	105"			124"
11' 6"	10"	21"	42"	63"	84"	105"			130"
12'	10"	21"	42"	63"	84"	105"	126"		136"
12' 6"	10"	21"	42"	63"	84"	105"	126"		142"
13'	10"	21"	42"	63"	84"	105"	126"		148"
13' 6"	10"	21"	42"	63"	84"	105"	126"	147"	154"
14'	10"	21"	42"	63"	84"	105"	126"	147"	160"

ALL TRACK ATTACHMENT SPACING +/-2' ALLOWED WITH SYP OR SPF NO. 2 OR BETTER ONLY

TABLE 3

Section Width (ft)	Panel Type	Max Design Loads Allowed	
		Positive (PSF)	Negative (PSF)
16' 2"	Short	23.9	27.1
16' 2"	Long	23.9	27.1
16' 2"	Oak Summit	23.9	27.1
16' 4"	Short	23.7	26.9
16' 4"	Long	23.7	26.9
16' 4"	Oak Summit	23.7	26.9
16' 6"	Short	23.4	26.6
16' 6"	Long	23.4	26.6
16' 6"	Oak Summit	23.4	26.6
16' 8"	Short	23.2	26.3
16' 8"	Long	23.2	26.3
16' 8"	Oak Summit	23.2	26.3
16' 10"	Short	23.0	26.1
16' 10"	Long	23.0	26.1
16' 10"	Oak Summit	23.0	26.1
17' 0"	Short	22.8	25.8
17' 0"	Long	22.8	25.8
17' 0"	Oak Summit	22.8	25.8
17' 2"	Short	22.5	25.6
17' 2"	Long	22.5	25.6
17' 2"	Oak Summit	22.5	25.6
17' 4"	Short	22.3	25.3
17' 4"	Long	22.3	25.3
17' 4"	Oak Summit	22.3	25.3
17' 6"	Short	22.1	25.1
17' 6"	Long	22.1	25.1
17' 6"	Oak Summit	22.1	25.1
17' 8"	Short	21.9	24.8
17' 8"	Long	21.9	24.8
17' 8"	Oak Summit	21.9	24.8
17' 10"	Short	21.7	24.6
17' 10"	Long	21.7	24.6
17' 10"	Oak Summit	21.7	24.6
18' 0"	Short	21.6	24.5
18' 0"	Long	21.6	24.5
18' 0"	Oak Summit	21.5	24.4

GLAZING IS AVAILABLE FOR ANY DOOR SIZE IF THE REQUIRED DESIGN PRESSURES ARE LESS THAN OR EQUAL TO (+21.6/-24.5)

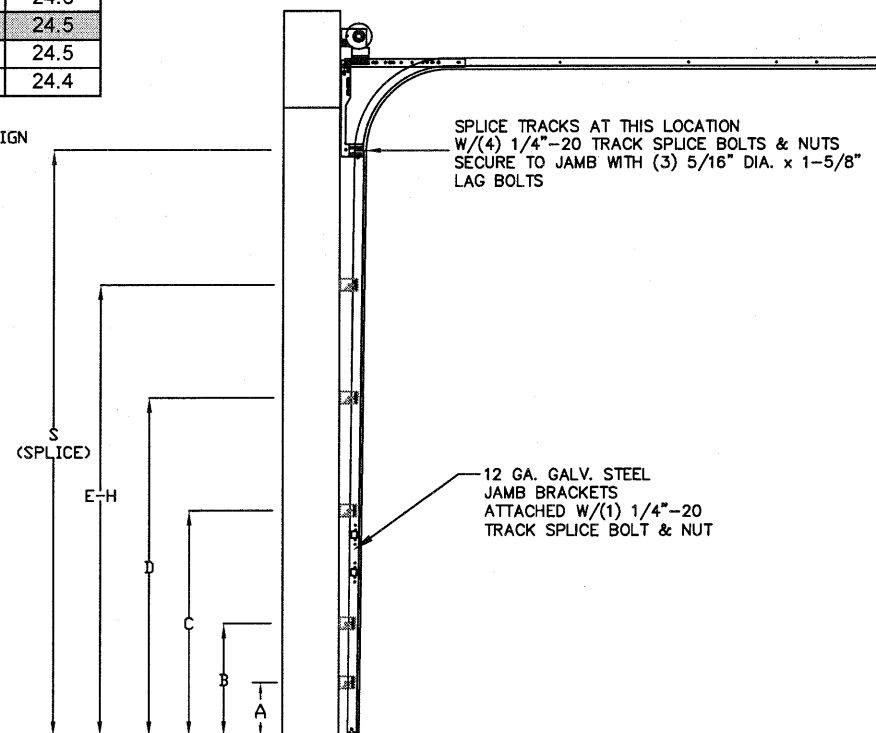

TRACK CONFIGURATION FOR 6'6" UP TO 14' TALL DOORS (SEE TABLE 2) N.T.S.

TABLE 4

Section Width (ft)	Panel Type	Center Stile Locations (Measured from Left Edge)		
		1st (in)	2nd (in)	3rd (in)
16' 2"	Short	50.27	97.00	143.73
16' 2"	Long	51.17	97.00	142.83
16' 2"	Oak Summit	48.75	97.00	145.25
16' 4"	Short	51.27	98.00	144.73
16' 4"	Long	52.17	98.00	143.83
16' 4"	Oak Summit	49.08	98.00	146.92
16' 6"	Short	52.27	99.00	145.73
16' 6"	Long	51.34	99.00	146.66
16' 6"	Oak Summit	49.42	99.00	148.59
16' 8"	Short	51.34	100.00	148.66
16' 8"	Long	52.20	100.00	147.80
16' 8"	Oak Summit	49.92	100.00	150.09
16' 10"	Short	51.50	101.00	150.50
16' 10"	Long	53.20	101.00	148.80
16' 10"	Oak Summit	50.15	101.00	151.59
17' 0"	Short	53.34	102.00	150.66
17' 0"	Long	54.20	102.00	149.80
17' 0"	Oak Summit	50.92	102.00	153.09
17' 2"	Short	53.00	103.00	153.00
17' 2"	Long	55.20	103.00	150.80
17' 2"	Oak Summit	51.42	103.00	154.59
17' 4"	Short	54.00	104.00	154.00
17' 4"	Long	56.20	104.00	151.80
17' 4"	Oak Summit	51.92	104.00	156.09
17' 6"	Short	55.00	105.00	155.00
17' 6"	Long	57.20	105.00	152.80
17' 6"	Oak Summit	52.42	105.00	157.59
17' 8"	Short	54.80	106.00	157.20
17' 8"	Long	55.80	106.00	156.20
17' 8"	Oak Summit	52.92	106.00	159.09
17' 10"	Short	55.80	107.00	158.20
17' 10"	Long	56.25	107.00	157.75
17' 10"	Oak Summit	53.42	107.00	160.59
18' 0"	Short	57.25	108.00	158.75
18' 0"	Long	57.80	108.00	158.20
18' 0"	Oak Summit	53.92	108.00	162.09

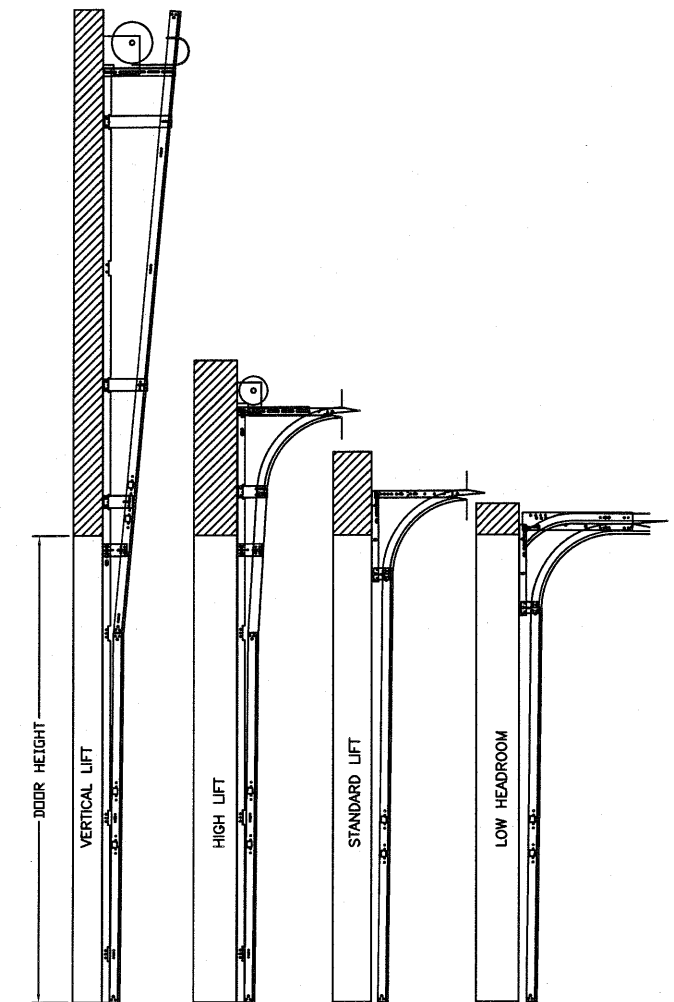

AVAILABLE TRACK CONFIGURATIONS N.T.S.

REV	DESCRIPTION OF REVISIONS	DATE	BY

MAX SIZE
18' WIDTH
14' HEIGHT
(DOOR HEIGHT SUBJECT TO WEIGHT LIMITATIONS)

DESIGN LOADS
+21.6 PSF
-24.5 PSF

TEST LOADS
(1.5 x DESIGN LOADS)
+32.4 PSF
-36.8 PSF

Thomas L. Shelmerdine, PE (TX PE #85829)
Structural Solutions, PA (TX Firm #F-004063)

STATE OF TEXAS
THOMAS L. SHELMERDINE
85829
LICENSED PROFESSIONAL ENGINEER
TX

Amarr

165 CARRIAGE COURT WINSTON-SALEM, N.C. 27105 WWW.AMARR.COM

MODEL #1500 STRATFORD 3000
MODEL #1200 HERITAGE 3000
MODEL #1550 OAK SUMMIT 3000
SHORT, LONG, FLUSH & OAK SUMMIT PANELS

SIZE	DRAWN BY	RLR	DATE 11/24/13	DRAWING NUMBER
B	CHECKED BY		DATE	IRC-1518-120-24

SHEET 3 OF 3

5921-G W. Friendly Ave., Greensboro, NC 27410