

(1) 4.5" X 20 GA. R-TRUSS ATTACHED W/(6) 1/4" X 3/4" HEX HEAD SCREWS AT EACH END (3) PER STILE AND W/(2) 1/4" X 3/4" HEX HEAD SCREWS AT EACH CENTER STILE

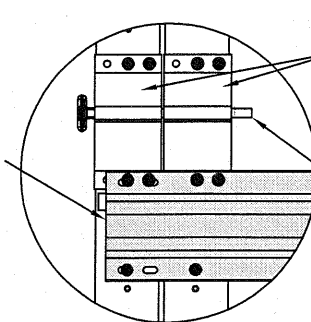

TYPICAL TOP FIXTURES
N.T.S. 1

(2) 12 GA. (MIN.) GALV. COMMERCIAL TOP ROLLER BRACKET ATTACHED W/(4) 1/4" X 3/4" HEX HEAD SCREWS PER BRACKET

2" DR 3" 10-BALL STEEL 9.5" LONG STEM HURRICANE ROLLERS W/ RETAINERS USED FOR NON THREADED SHAFTS

(1) 3" X 20 GA. STRUT ATTACHED W/(4) 1/4" X 3/4" HEX HEAD SCREWS AT EACH END (2) PER STILE AND W/(2) 1/4" X 3/4" HEX HEAD SCREWS AT EACH CENTER STILE

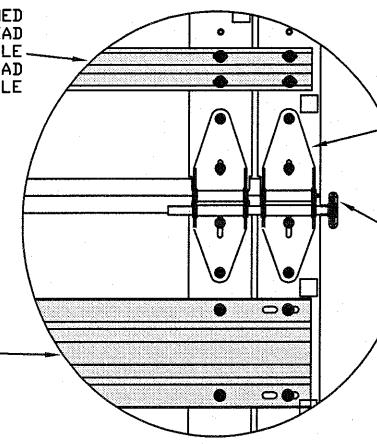

TYPICAL END HINGE
N.T.S. 3

14 GA. (MIN.) END HINGE ROLLER CARRIERS ATTACHED W/(4) 1/4" X 3/4" HEX HEAD SCREWS EACH

2" DR 3" 10-BALL STEEL 9.5" LONG STEM HURRICANE ROLLERS W/ RETAINERS USED FOR NON THREADED SHAFTS

(1) 4.5" X 20 GA. R-TRUSS ATTACHED W/(4) 1/4" X 3/4" HEX HEAD SCREWS AT EACH END (2) PER STILE AND W/(2) 1/4" X 3/4" HEX HEAD SCREWS AT EACH CENTER STILE

3" 20GA STRUT ATTACHED W/(2) 1/4" X 3/4" HEX HEAD SCREWS AT EACH CENTER STILE

14GA. (MIN.) CENTER HINGE ATTACHED W/(4) 1/4" X 3/4" HEX HEAD SCREWS

4.5" 20GA R-TRUSS ATTACHED W/(2) 1/4" X 3/4" HEX HEAD SCREWS AT EACH CENTER STILE

TYPICAL CENTER HINGE
N.T.S. 2

(1) 3" X 20 GA. STRUT ATTACHED W/(4) 1/4" X 3/4" HEX HEAD SCREWS AT EACH END (2) PER STILE AND W/(2) 1/4" X 3/4" HEX HEAD SCREWS AT EACH CENTER STILE

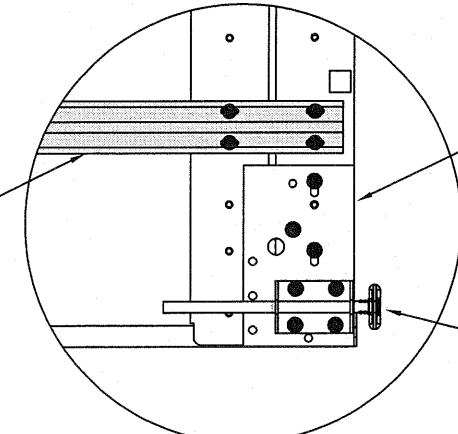

TYPICAL BOTTOM BRACKET
N.T.S. 4

BOTTOM BRACKET 11 GA. (MIN.) ATTACHED W/(7) 1/4" X 3/4" HEX HEAD SCREWS

2" DR 3" 10-BALL STEEL 9.5" LONG STEM HURRICANE ROLLER W/ RETAINER USED FOR NON THREADED SHAFTS

(2) 12 GA. COMMERCIAL TOP ROLLER BRACKET ATTACHED W/(4) 1/4" X 3/4" HEX HEAD SCREWS PER BRACKET ADJUSTABLE SLIDE BRACKET IS ASSEMBLED W/(2) 5/16" X 3/4" BOLT & NUT PER BRACKET.

MODEL 2400 24 GA. (.022" MIN) DR MODEL 2000 20 GA (.034 MIN) PREPAINTED STEEL

(1) 3" X 20 GA. STRUT ATTACHED W/(4) 1/4" X 3/4" HEX HEAD SCREWS AT EACH END (2) PER STILE AND W/(2) 1/4" X 3/4" HEX HEAD SCREWS AT EACH CENTER STILE

(1) 4.5" X 20 GA. R-TRUSS ATTACHED W/(4) 1/4" X 3/4" HEX HEAD SCREWS AT EACH END (2) PER STILE AND W/(2) 1/4" X 3/4" HEX HEAD SCREWS AT EACH CENTER STILE

(2) 14 GA. (MIN.) END HINGE ROLLER CARRIERS ATTACHED W/(4) 1/4" X 3/4" HEX HEAD SCREWS EACH

2" 10 BALL STEEL 9.5" LONG STEM HURRICANE ROLLER W/ RETAINER USED FOR NON THREADED SHAFTS

BOTTOM BRACKET 11 GA. ATTACHED W/(7) 1/4" X 3/4" HEX HEAD SCREWS

CONT. ALUM EXTRUSION WITH CONT. VINYL ASTRAGAL

SECTION A-A (SIDE VIEW)
N.T.S.

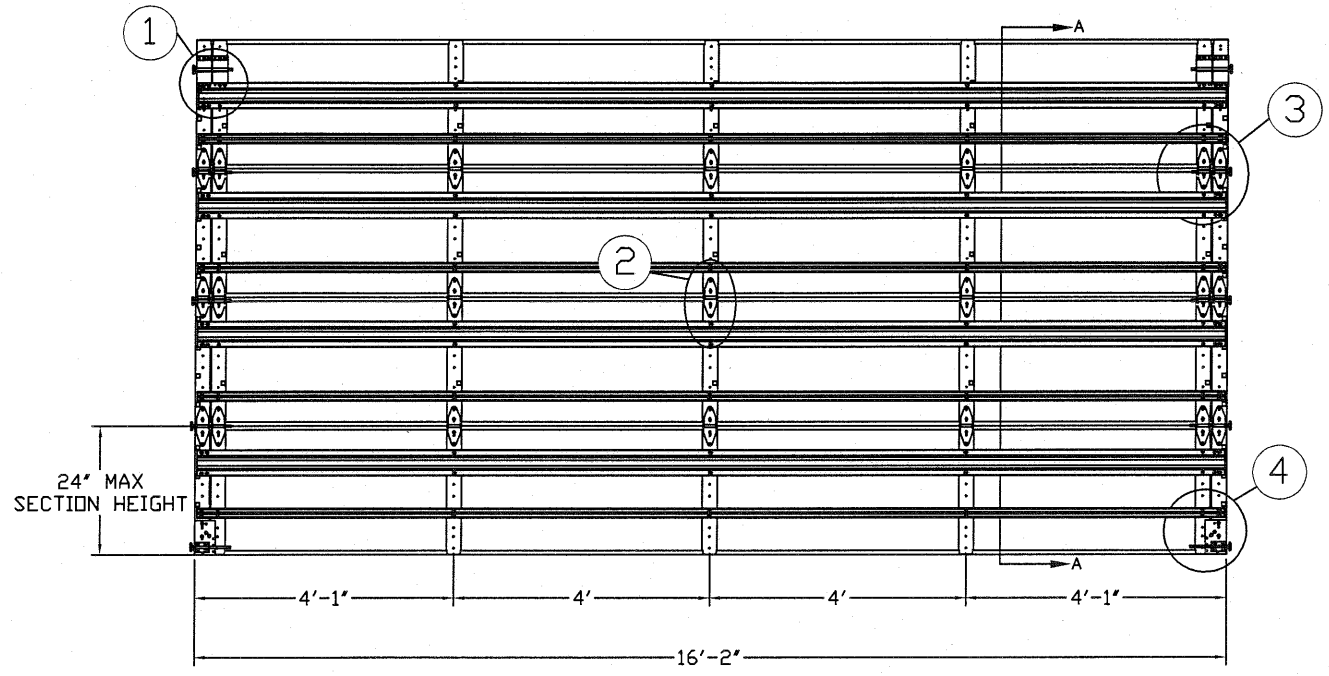

INSIDE ELEVATION
N.T.S.

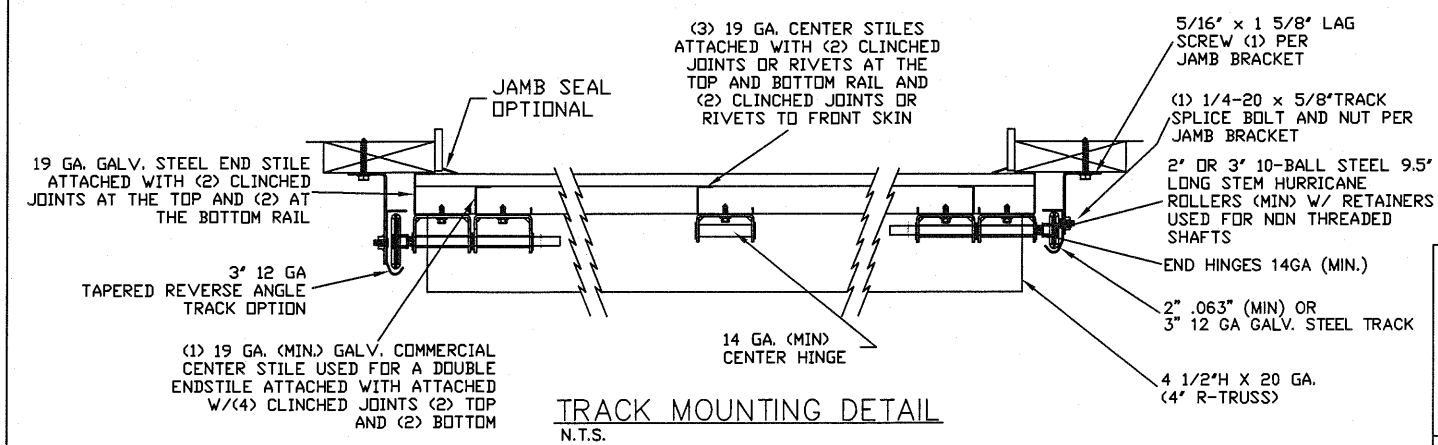

TRACK MOUNTING DETAIL
N.T.S.

EDGE OF DOOR 1" OVERLAP ON EACH SIDE

THE METHOD OF TESTING WAS IN SUBSTANTIAL CONFORMANCE WITH THE PROCEDURES DESCRIBED IN DASMA 108. THE PRESSURES SHOWN ON THE DRAWINGS WERE CALCULATED USING ASCE 7-98/02/05 WITH THE FOLLOWING PARAMETERS (5 FEET OF DOOR WIDTH IN END ZONE, ROOF SLOPE 10° OR LESS, AND I=1.0):

WIND SPEED (MPH)	140	127	121	115	111
EXPOSURE LEVEL	B	C	C	D	D
MEAN ROOF HEIGHT	30'	15'	25'	15'	25'

REV	DESCRIPTION OF REVISIONS	DATE	BY
A	ADDED GLAZING OPTIONS	6/18/14	RS

MAX SIZES
WIDTH 16'-2"
HEIGHT 24'

DESIGN LOADS
+27.0 PSF
-30.6 PSF

TEST LOADS
+40.5 PSF
-45.9 PSF

Thomas L. Shelmerdine, PE (TX PE #85829)
Structural Solutions, PA (TX Firm #004063)

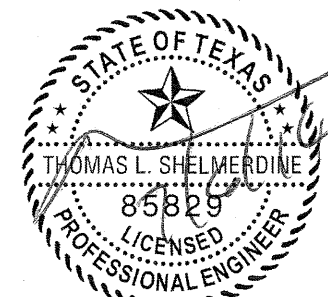

TX

Amarr

ENTRE/MATIC

165 CARRIAGE COURT WINSTON-SALEM, N.C. 27105 WWW.AMARR.COM

MODEL 2400 (24 GA)
MODEL 2000 (20 GA)

SIZE	DRAWN BY	RLR	DATE	8/7/12	DRAWING NUMBER
B	CHECKED BY		DATE		IBC-2416-140-24

5921-G W. Friendly Ave., Greensboro, NC 27410

TRACK CONNECTION DIRECTLY TO STRUCTURE OPTIONS

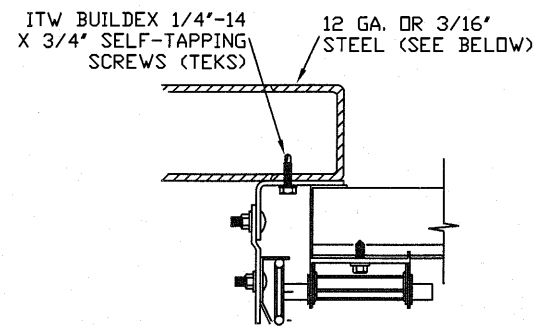

CLIP STYLE REVERSE ANGLE MOUNT SHOWN
BRACKET, CONTINUOUS AND TAPERED ANGLE
MOUNT AVAILABLE

12 GA. STEEL FRAMING
232 LBS./SCREW ALLOWABLE LOAD - 6'
FROM ENDS AND 12' O.C.
REFER TO NOTES: 1, 2 AND 5

3/16" STEEL FRAMING
569 LBS./SCREW ALLOWABLE LOAD - 6'
FROM ENDS AND 24' O.C.
REFER TO NOTES: 1, 2 AND 5

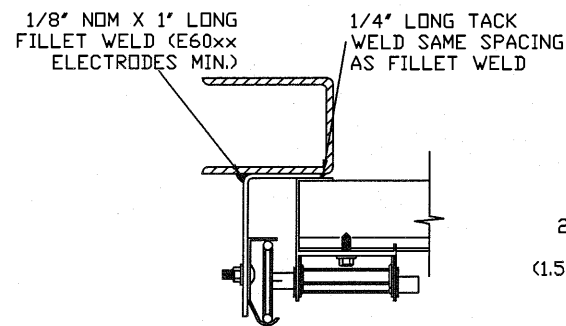

REVERSE ANGLE MOUNT SHOWN
BRACKET, CONTINUOUS AND
TAPERED ANGLE MOUNT AVAILABLE

STEEL FRAMING 12GA DR BETTER
1590 LBS./IN. ALLOWABLE LOAD -
6' FROM ENDS AND 24' O.C.
REFER TO NOTES: 1, 2, 5, 6, 7, 8
AND 9

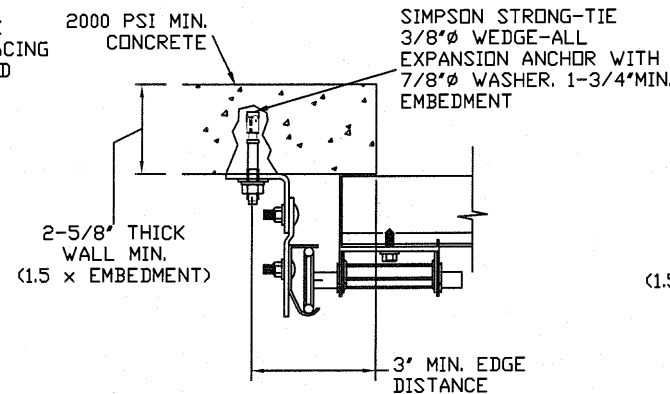

CLIP STYLE CONTINUOUS ANGLE MOUNT SHOWN
BRACKET, REVERSE AND TAPERED ANGLE MOUNT
AVAILABLE

2000 PSI CONCRETE OR GREATER
351 LBS./EXPANSION ANCHOR ALLOWABLE LOAD -
6' FROM ENDS AND 18' O.C.
REFER TO NOTES: 1, 2, 3, 4 AND 5

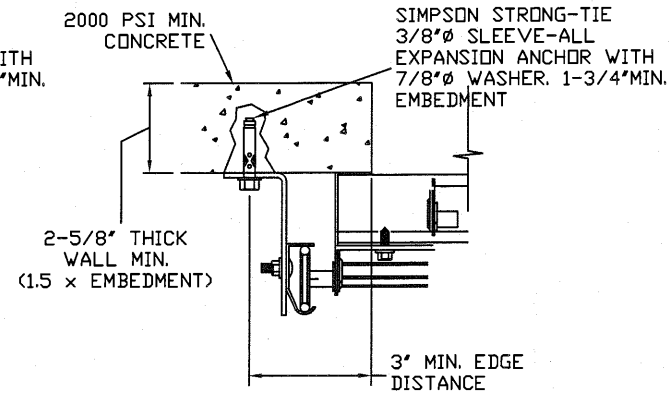

CONTINUOUS ANGLE MOUNT SHOWN
BRACKET, CONTINUOUS AND TAPERED ANGLE
MOUNT AVAILABLE

2000 PSI CONCRETE OR GREATER
336 LBS./EXPANSION ANCHOR ALLOWABLE
LOAD - 6' FROM ENDS AND 18' O.C.
REFER TO NOTES: 1, 2, 3, 4 AND 5

NOTES:

- ANCHORS TO BE EVENLY SPACED BETWEEN THE HEADER AND FLOOR.
- FIRST (BOTTOM) ANCHOR STARTING AT NO MORE THAN HALF OF THE MAXIMUM ON-CENTER DISTANCE. HIGHEST ANCHOR INSTALLED AT LEAST AS HIGH AS THE DOOR OPENING.
- MIN. EDGE DISTANCE OF 3' REQUIRED.
- USE WASHERS PROVIDED BY THE ANCHOR MANUFACTURER.
- SUPPORTING STRUCTURAL ELEMENTS SHALL BE DESIGNED BY A REGISTERED PROFESSIONAL ENGINEER FOR WIND LOADS IN ADDITION TO OTHER LOADS.
- MOST GARAGE DOOR TRACK IS GALVANIZED STEEL. USE ALL NECESSARY PRECAUTIONS WHEN WELDING GALVANIZED STEEL.
- ALL WELDS SHOULD BE PERFORMED BY A CERTIFIED WELDER OR INSPECTED BY A CERTIFIED WELDING INSPECTOR TO VERIFY THE INTEGRITY OF THE WELD.
- FILLET WELDS TO HAVE A STRAIGHT OR CONVEX FACE SURFACE.
- TACK WELD TOE OF ANGLE AT SAME SPACING TO PREVENT ROTATION OF TRACK ANGLE.

SPECIFICATIONS AND NOTES

- ALL THE LOAD FROM THE DOOR IS TRANSFERRED TO THE VERTICAL TRACK. FROM THE TRACK THE LOAD IS TRANSFERRED TO THE VERTICAL JAMBS. THE HORIZONTAL JAMB OR HEADER RECEIVES NO PORTION OF THE LOAD TRANSFERRED FROM THE DOOR.
- EACH VERTICAL JAMBS RECEIVES MAXIMUM DESIGN LOADS OF: +218.3 LBS/FT AND -247.4 LBS/FT
- DOOR AND HARDWARE WILL BE DESIGNED, MANUFACTURED AND INSTALLED WITH STANDARDS AS SET FORTH BY DASMA.
- DOOR SECTIONS SHALL BE 24 GA. (.022) MIN. EXTERIOR SKIN ROLLED FORMED, GALVANIZATION W/ BAKED ON POLYESTER FINISH
- DOORS UP TO 24' HIGH USE (1) 4 1/2" R-TRUSS AND (1) 3" STRUT PER SECTION
- SUPPORTING STRUCTURAL ELEMENTS SHALL BE DESIGNED BY A REGISTERED PROFESSIONAL ENGINEER FOR WIND LOADS INDICATED ON THIS DRAWING IN ADDITION TO OTHER LOADINGS.

WOOD JAMB ATTACHMENT TO STRUCTURE (OPTIONAL)

2 X 6 VERTICAL JAMB ATTACHMENT TO WOOD FRAME STRUCTURE
5/16" X 3" LAG SCREWS STARTING 6" FROM ENDS THEN 22" O.C. (1 1/2" EMBEDMENT)

2 X 6 VERTICAL JAMB ATTACHMENT TO 2,000 PSI CONCRETE
HILTI KWIK BOLT 3/8" X 4" STARTING 6" FROM ENDS THEN 24" O.C. (2 1/2" EMBEDMENT)
HILTI SLEEVE ANCHOR 3/8" X 2-3/4" STARTING 6" FROM ENDS THEN 20" O.C. (1 1/4" EMBEDMENT)
ITW/RAMSET REDHEAD (TRU-BOLT) 3/8" X 4" STARTING 6" FROM ENDS THEN 24" O.C. (2 1/2" EMBEDMENT)

2 X 6 VERTICAL JAMB ATTACHMENT TO HOLLOW C-90 BLOCK
SIMPSON 1/4" X 3" TITEN SCREWS STARTING 6" FROM ENDS, USE PAIRS OF FASTENERS (3" APART) AT 16" O.C. (1 1/2" EMBEDMENT)
HILTI 1/4" X 2-3/4" KWIK-CON II+ SCREWS STARTING 6" FROM ENDS, USE PAIRS OF FASTENERS (3" APART) AT 16" O.C. (1 1/4" EMBEDMENT)

2 X 6 VERTICAL JAMB ATTACHMENT TO GROUTED C-90 BLOCK (2000 PSI GROUT)
HILTI SLEEVE ANCHOR 3/8" X 2-3/4" STARTING 6" FROM ENDS THEN 22" O.C. (1 1/4" EMBEDMENT)
(OR, USE FASTENERS FOR HOLLOW C-90 BLOCK)

*LAGS AND BOLTS CAN BE COUNTERSUNK TO PROVIDE A FLUSH MOUNTING SURFACE.
*PREPARATION OF WOOD JAMBS BY OTHERS

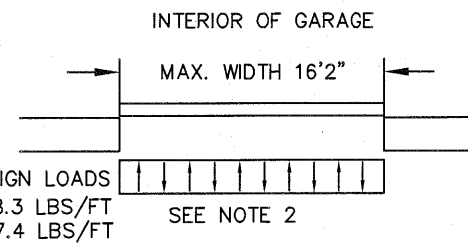
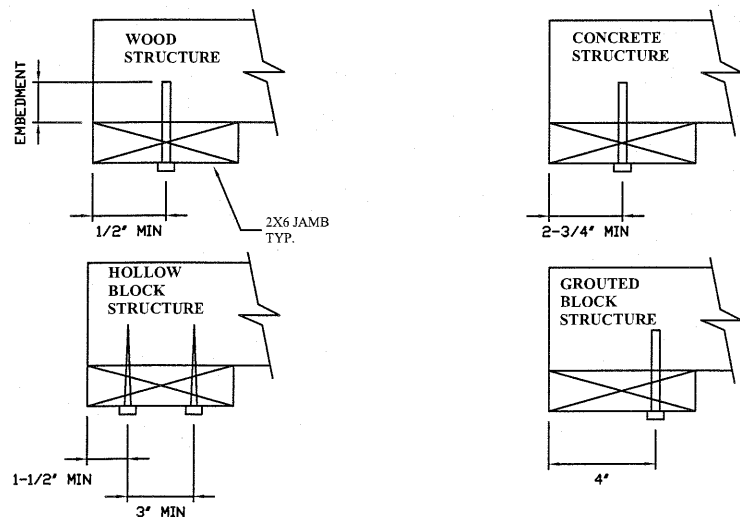

TRACK CONNECTION TO WOOD JAMB OPTIONS

FOR LAG SCREWS & BRACKET SPACING SEE TABLE 2 ON PAGE 4

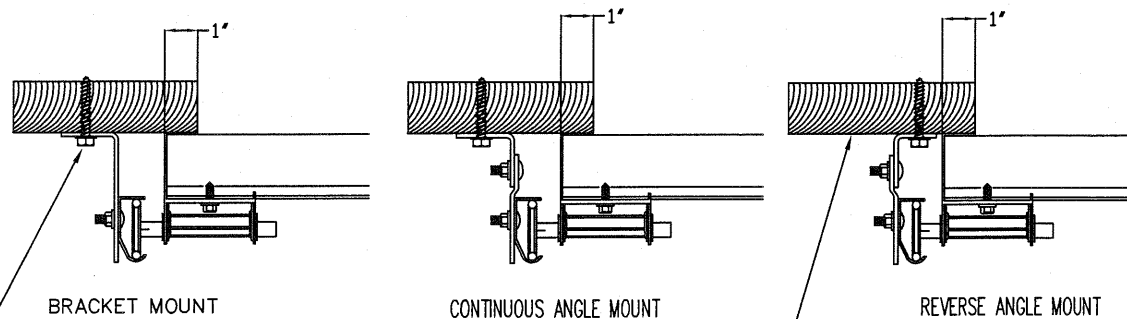

5/16" x 1 5/8" LAG SCREW (1)
PER JAMB BRACKET (1-1/2"
EMBEDMENT MINIMUM) (TYP.)

2x6 WOOD JAMB SYP
(NO.2) OR BETTER (TYP.)

REV	DESCRIPTION OF REVISIONS	DATE	BY
A	ADDED GLAZING OPTIONS	6/18/14	RS

MAX SIZES
WIDTH 16'-2"
HEIGHT 24'

DESIGN LOADS
+27.0 PSF
-30.6 PSF

TEST LOADS
+40.5 PSF
-45.9 PSF

Thomas L. Shelmerdine, PE (TX PE #85829)
Structural Solutions, PA (TX Firm #F-004063)



5921-G W. Friendly Ave., Greensboro, NC 27410

Amarr
ENTRE/MATIC

165 CARRIAGE COURT WINSTON-SALEM, N.C. 27105 WWW.AMARR.COM

MODEL 2400 (24 GA)
MODEL 2000 (20 GA)

SIZE	DRAWN BY	RLR	DATE	8/7/12	DRAWING NUMBER
B	CHECKED BY		DATE		IBC-2416-140-24

SHEET 2 OF 4

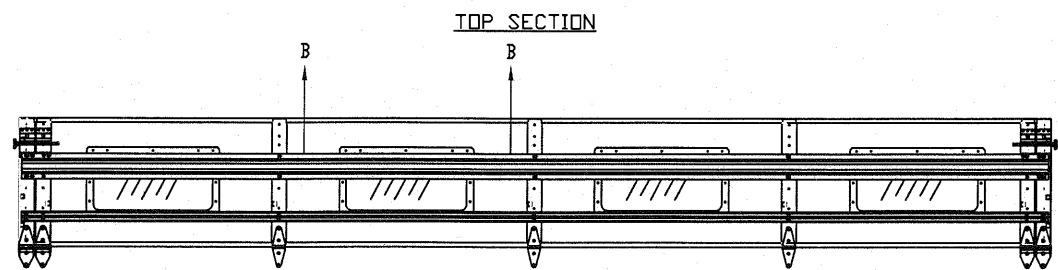

TOP SECTION

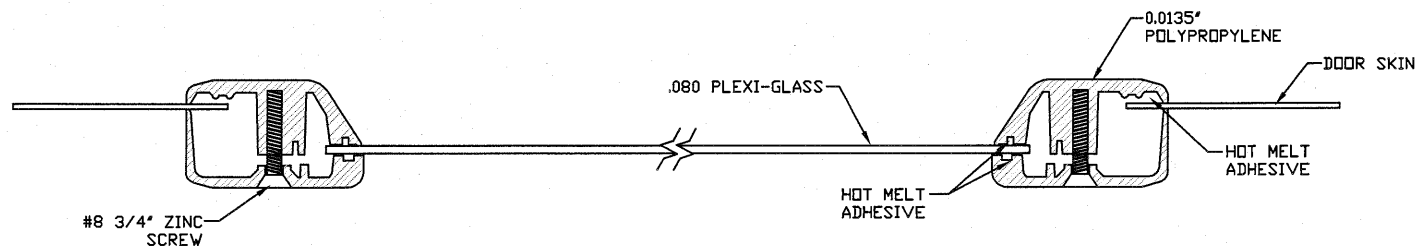

SECTION B-B 24' X 12' WINDOW DETAIL W/ .080 PLEXI-GLASS
N.T.S.

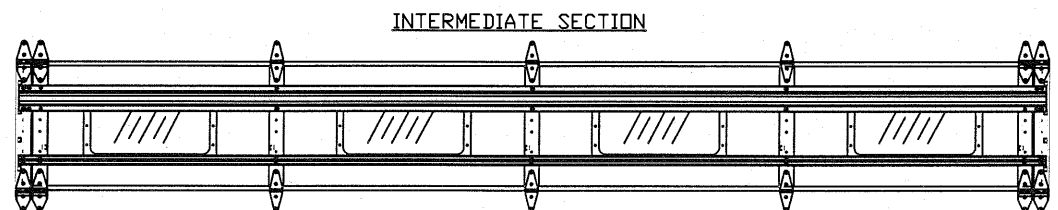

INTERMEDIATE SECTION

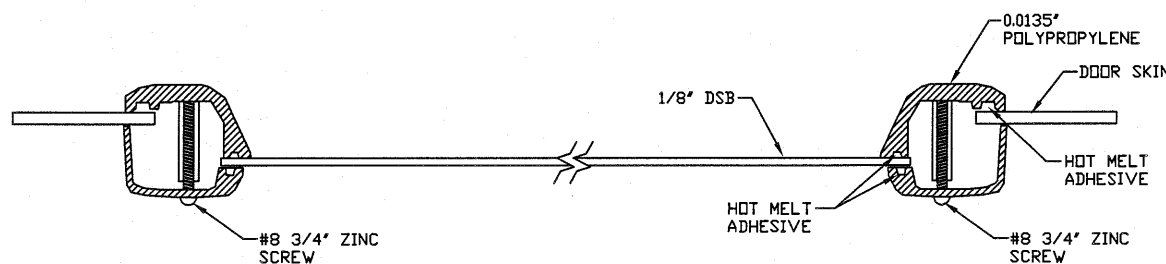

SECTION C-C 24' X 6' WINDOW DETAIL W/ 1/8\"/>

OPTIONAL GLAZED SECTION W/ 24' X 12' WINDOWS AND R-TRUSS LAYOUT
N.T.S.

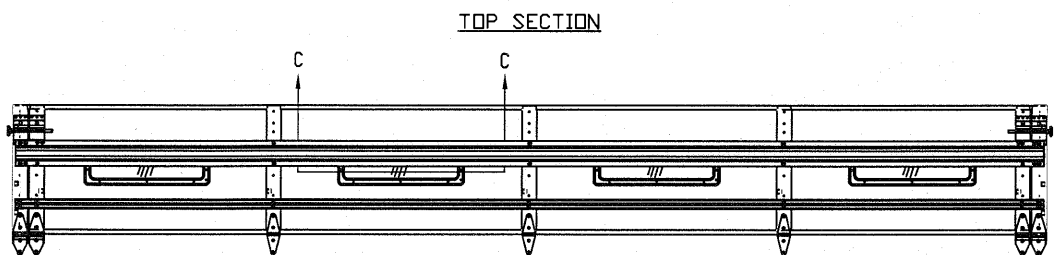

TOP SECTION

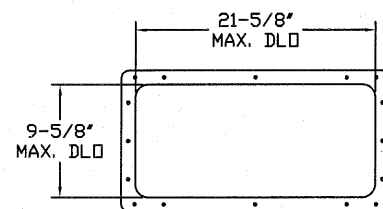

24' X 12' DAY LIGHT OPENING AND FASTENER DETAIL
N.T.S.

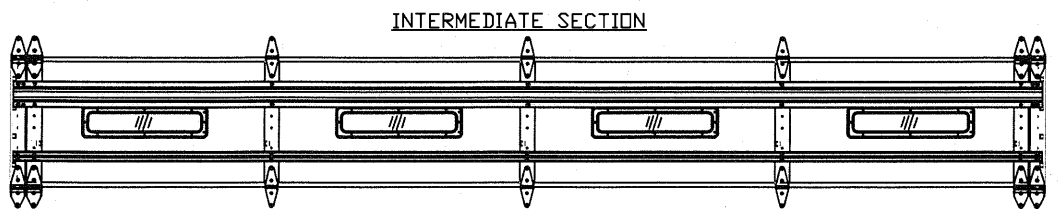

INTERMEDIATE SECTION

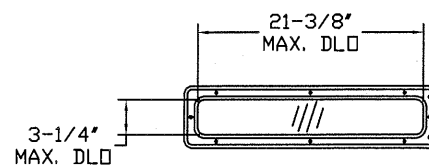

24' X 6' DAY LIGHT OPENING AND FASTENER DETAIL
N.T.S.

OPTIONAL GLAZED SECTION W/ 24' X 6' WINDOWS AND R-TRUSS LAYOUT
N.T.S.

REV	DESCRIPTION OF REVISIONS	DATE	BY
A	ADDED GLAZING OPTIONS	6/18/14	RS

MAX SIZES
WIDTH 16'-2"
HEIGHT 24'

DESIGN LOADS
+27.0 PSF
-30.6 PSF
TEST LOADS
+40.5 PSF
-45.9 PSF

Thomas L. Shelmerdine, PE (TX PE #85829)
Structural Solutions, PA (TX Firm #F-004063)



TX

5921-G.W. Friendly Ave., Greensboro, NC 27410

Amarr

ENTREMATIC

165 CARRIAGE COURT WINSTON-SALEM, NC. 27105 WWW.AMARR.COM

MODEL 2400 (24 GA)
MODEL 2000 (20 GA)

SIZE	DRAWN BY	RLR	DATE	8/7/12	DRAWING NUMBER
B	CHECKED BY		DATE		IEC-2416-140-24

SHEET 3 OF 4

TABLE 1

Section Width (ft)	Center Stile Locations (Measured from Left)			Max Design Loads Allowed	
	1st (in)	2nd (in)	3rd (in)	Positive (PSF)	Negative (PSF)
9' 4"	36"	76"	-	34.2	38.8
9' 6"	37"	77"	-	33.8	38.3
9' 8"	38"	78"	-	33.4	37.8
9' 10"	39"	79"	-	32.9	37.3
10' 0"	40"	80"	-	32.5	36.9
10' 2"	41"	81"	-	32.1	36.4
10' 4"	42"	82"	-	31.7	36.0
10' 6"	43"	83"	-	31.3	35.5
10' 8"	44"	84"	-	31.0	35.1
10' 10"	45"	85"	-	30.6	34.7
11' 0"	46"	86"	-	30.3	34.3
11' 2"	47"	87"	-	29.9	33.9
11' 4"	48"	88"	-	29.6	33.5
11' 6"	49"	89"	-	29.2	33.1
11' 8"	50"	90"	-	28.9	32.8
11' 10"	51"	91"	-	28.6	32.4
12' 0"	48"	96"	-	27.1	30.7
13' 0"	36"	78"	120"	31.0	35.1
13' 2"	37"	79"	121"	31.0	35.1
13' 4"	38"	80"	122"	31.0	35.1
13' 6"	39"	81"	123"	31.0	35.1
13' 8"	40"	82"	124"	31.0	35.1
13' 10"	41"	83"	125"	31.0	35.1
14' 0"	42"	84"	126"	31.0	35.1
14' 2"	43"	85"	127"	30.6	34.7
14' 4"	44"	86"	128"	30.3	34.3
14' 6"	45"	87"	129"	29.9	33.9
14' 8"	46"	88"	130"	29.6	33.5
14' 10"	47"	89"	131"	29.2	33.1
15' 0"	48"	90"	132"	28.9	32.8
15' 2"	49"	91"	133"	28.6	32.4
15' 4"	50"	92"	134"	28.3	32.1
15' 6"	51"	93"	135"	28.0	31.7
15' 8"	52"	94"	136"	27.7	31.4
15' 10"	53"	95"	137"	27.4	31.0
16' 0"	48"	96"	144"	27.1	30.7
16' 2"	49"	97"	145"	27.0	30.6

*FOR WIDTHS 12'-2" TO 12'-10" CONTACT ENGINEERING FOR STILE PLACEMENT

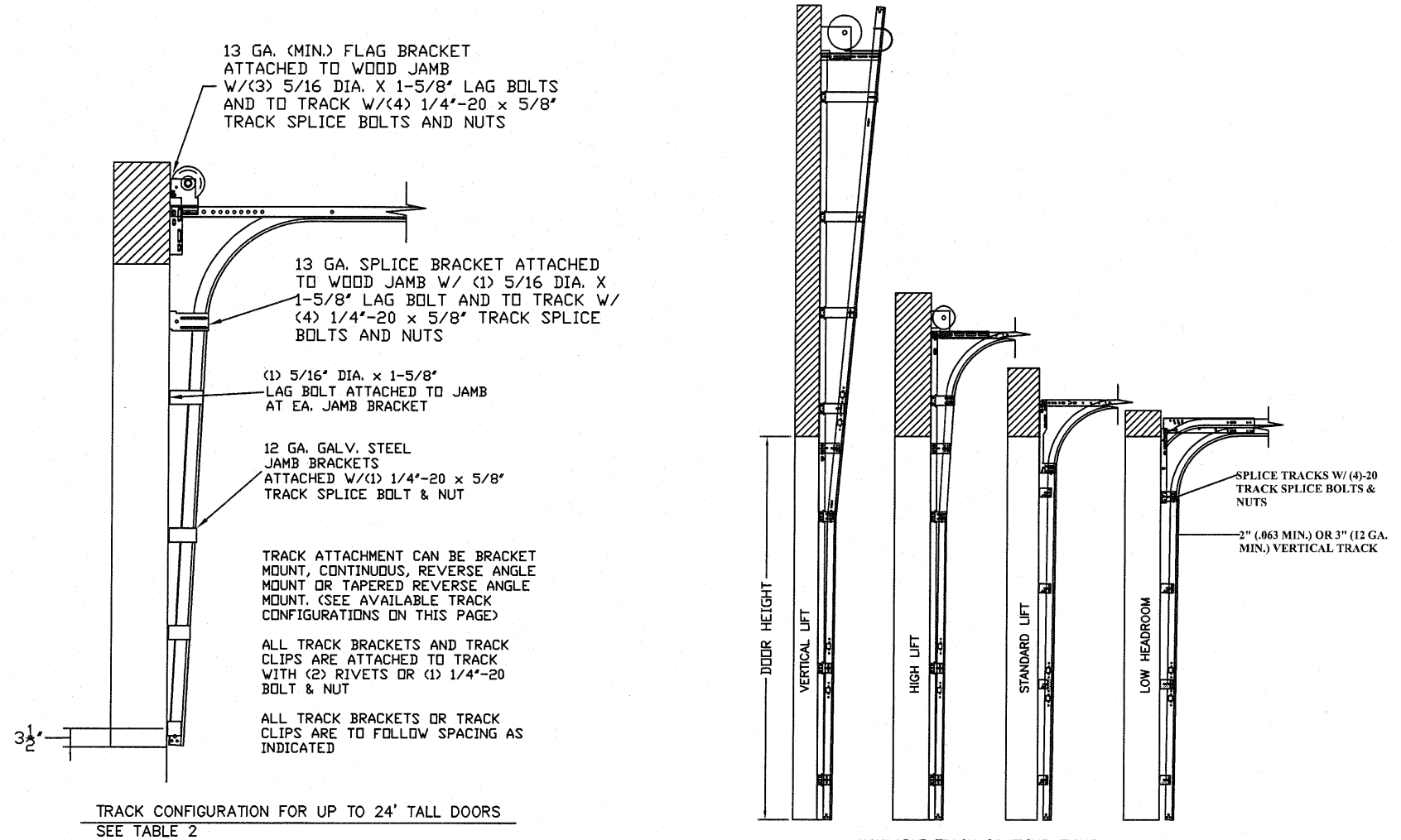

TRACK CONFIGURATION FOR UP TO 24' TALL DOORS SEE TABLE 2

AVAILABLE TRACK CONFIGURATIONS N.T.S.

TABLE 2

DOOR HEIGHT	TRACK ATTACHMENT												TYPICAL SPLICE
	A	B	C	D	E	F	G	H	I	J	K	L	
7' 0"	3.5"	22"	44"										76"
7' 6"	3.5"	22"	44"	68"									82"
8' 0"	3.5"	22"	44"	75"									88"
8' 6"	3.5"	22"	44"	75"									94"
9' 0"	3.5"	22"	44"	75"									100"
9' 6"	3.5"	22"	44"	68"	92"								106"
10' 0"	3.5"	22"	44"	68"	92"								112"
11' 0"	3.5"	22"	44"	68"	92"	116"							124"
12' 0"	3.5"	22"	44"	68"	92"	116"							136"
13' 0"	3.5"	22"	44"	68"	92"	116"							148"
14' 0"	3.5"	22"	44"	68"	92"	116"	140"						160"
15' 0"	3.5"	22"	44"	68"	92"	116"	140"						172"
16' 0"	3.5"	22"	44"	68"	92"	116"	140"	154"					184"
17' 0"	3.5"	22"	44"	68"	92"	116"	140"	154"	178"				196"
18' 0"	3.5"	22"	44"	68"	92"	116"	140"	154"	178"				208"
19' 0"	3.5"	22"	44"	68"	92"	116"	140"	154"	178"	202"			220"
20' 0"	3.5"	22"	44"	68"	92"	116"	140"	154"	178"	202"			232"
21' 0"	3.5"	22"	44"	68"	92"	116"	140"	154"	178"	202"	226"		244"
22' 0"	3.5"	22"	44"	68"	92"	116"	140"	154"	178"	202"	226"		256"
23' 0"	3.5"	22"	44"	68"	92"	116"	140"	154"	178"	202"	226"		268"
24' 0"	3.5"	22"	44"	68"	92"	116"	140"	154"	178"	202"	226"	250"	280"

REV	DESCRIPTION OF REVISIONS	DATE	BY
A	ADDED GLAZING OPTIONS	6/18/14	RS

MAX SIZES
WIDTH 16'-2"
HEIGHT 24'

DESIGN LOADS
+27.0 PSF
-30.6 PSF

TEST LOADS
+40.5 PSF
-45.9 PSF

Thomas L. Shelmerdine, PE (TX PE #85829)
Structural Solutions, PA (TX Firm #F-004063)

TX

5921-G.W. Friendly Ave., Greensboro, NC 27410

ENTREMATIC

165 CARRIAGE COURT WINSTON-SALEM, N.C. 27105 WWW.AMARR.COM

MODEL 2400 (24 GA)
MODEL 2000 (20 GA)

SIZE	DRAWN BY	RLR	DATE	8/7/12	DRAWING NUMBER
B	CHECKED BY		DATE		IBC-2416-140-24

SHEET 4 OF 4