

NOTE: FOR STRUT SCHEDULE SEE TABLE 4 ON PAGE 3

THE METHOD OF TESTING WAS IN SUBSTANTIAL CONFORMANCE WITH THE PROCEDURE DESCRIBED IN ASTM E330 AND ANSI/DASMA 108. THE PRESSURES SHOWN ON THE DRAWINGS WERE CALCULATED USING ASCE 7-16 WITH THE FOLLOWING PARAMETERS (5 FEET OF DOOR WIDTH IN THE END ZONE, ROOF AT ANY SLOPE):

WIND SPEED (MPH)	155	140	133	127	122
EXPOSURE LEVEL	B	C	C	D	D
MEAN ROOF HEIGHT	30'	15'	25'	15'	25'

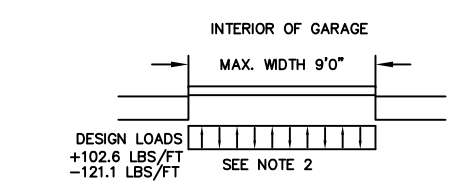

- SPECIFICATIONS AND NOTES**
- ALL THE LOAD FROM THE DOOR IS TRANSFERRED TO THE VERTICAL TRACK, FROM THE TRACK THE LOAD IS TRANSFERRED TO THE VERTICAL JAMBS. THE HORIZONTAL JAMB OR HEADER RECEIVES NO PORTION OF THE LOAD TRANSFERRED FROM THE DOOR.
 - EACH VERTICAL JAMBS RECEIVES MAXIMUM DESIGN LOADS OF: +102.6 LBS/FT & -121.1 LBS/FT
 - DOORS AND HARDWARE WILL BE DESIGNED, MANUFACTURED AND INSTALLED WITH STANDARDS AS SET FORTH BY DASMA.
 - DOOR SECTIONS SHALL BE 25 GA. MIN. (.019") ROLLED FORMED LIGHT COMMERCIAL QUALITY.
 - SUPPORTING STRUCTURAL ELEMENTS SHALL BE DESIGNED BY A REGISTERED PROFESSIONAL ENGINEER FOR WIND LOADS INDICATED ON THIS DRAWING IN ADDITION TO OTHER LOADINGS.
 - REFER TO TABLES ON PAGE 3 FOR ADDITIONAL DOOR WIDTHS AND THEIR DESIGN PRESSURES
 - DOOR IS MANUFACTURED AND TESTED IN ACCORDANCE WITH THE 2018 IRC/IBC

REV	DESCRIPTION OF REVISIONS	DATE	BY

MAX SIZE 9' x 14'

DESIGN LOADS
+22.8 PSF
-26.9 PSF

TEST LOADS
+34.2 PSF
-40.4 PSF

STATE OF TEXAS
See Digital Signature
THOMAS L. SHELMERDINE
85829
LICENSED PROFESSIONAL ENGINEER

This document has been digitally signed & sealed by Thomas L. Shelmerdine, PE on the date shown. Printed copies of this document are not considered signed & sealed, and the signature must be verified on any electronic copies.

Thomas L. Shelmerdine, PE (TX PE #85829)
Structural Solutions, PA (TX Firm #F-004063)
5921-G W. Friendly Ave., Greensboro, NC 27410 TX

Amarr

MODEL #625 AMARR LINCOLN 1000, 2000
MODEL #675 AMARR HILLCREST 1000, 2000

SIZE	DRAWN BY	DRC	DATE	DRAWING NUMBER
B	CHECKED BY	DLJ	DATE 12/31/19	IRC-6209-120-15

AMARR COMPANY
165 CARRIAGE COURT WINSTON-SALEM, N.C. 27105 SHEET 1 OF 3

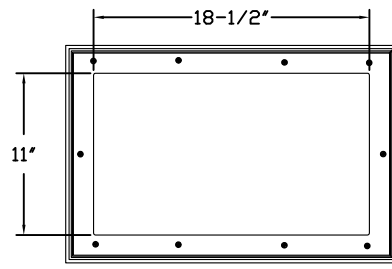

SHORT PANEL GLAZING FASTENER DETAIL
N.T.S.

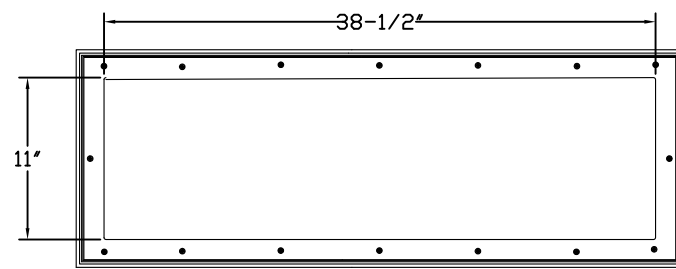

LONG PANEL GLAZING FASTENER DETAIL
N.T.S.

GLAZING OPTION CROSS SECTION

GLAZING NOT AVAILABLE IN WIND-BORNE DEBRIS REGION
GLAZING MEETS ASTM E1300-04

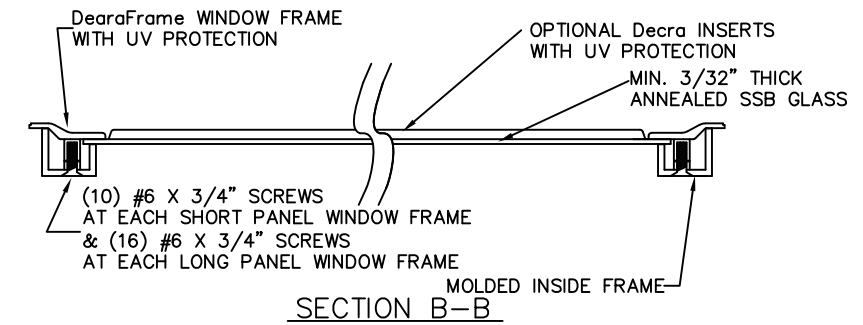

SECTION B-B

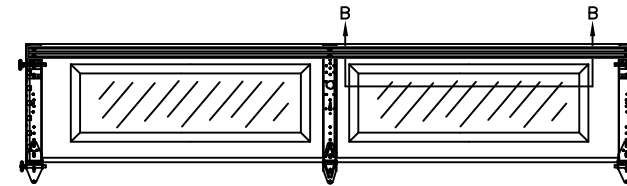

OPTIONAL LONG PANEL TOP GLAZED SECTION LAYOUT

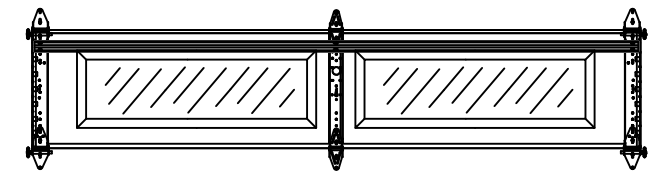

OPTIONAL LONG PANEL INTERMEDIATE GLAZED SECTION LAYOUT

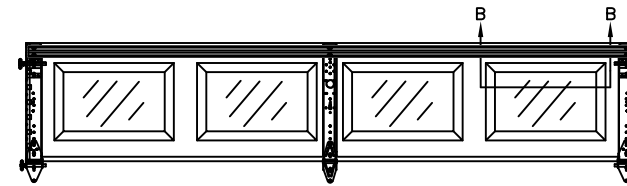

OPTIONAL SHORT PANEL TOP GLAZED SECTION LAYOUT

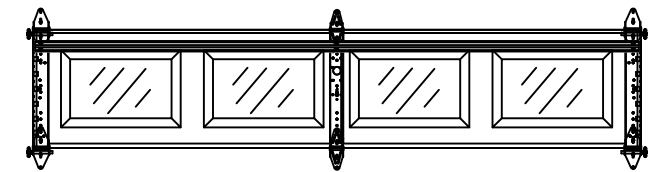

OPTIONAL SHORT PANEL INTERMEDIATE GLAZED SECTION LAYOUT

WOOD JAMB ATTACHMENT TO STRUCTURE (OPTIONAL)

2 X 6 VERTICAL JAMB ATTACHMENT TO WOOD FRAME STRUCTURE

5/16" X 3" LAG SCREWS STARTING 6" FROM ENDS
THEN 24" O.C. (1 1/2" EMBEDMENT)

2 X 6 VERTICAL JAMB ATTACHMENT TO 2,000 PSI CONCRETE

HILTI KWIK BOLT 3/8" X 4" STARTING 6" FROM ENDS
THEN 24" O.C. (2 1/2" EMBEDMENT)

HILTI SLEEVE ANCHOR 3/8" X 2-3/4" STARTING 6" FROM ENDS
THEN 24" O.C. (1 1/4" EMBEDMENT)

ITW/RAMSET REDHEAD (TRU-BOLT) 3/8" X 4" STARTING 6" FROM ENDS
THEN 24" O.C. (2 1/2" EMBEDMENT)

2 X 6 VERTICAL JAMB ATTACHMENT TO HOLLOW C-90 BLOCK

SIMPSON 1/4" X 3" TITEN SCREWS STARTING 6" FROM ENDS,
USE PAIRS OF FASTENERS (3" APART)
AT 24" O.C. (1 1/2" EMBEDMENT)

HILTI 1/4" X 2-3/4" KWIK-CON II+ SCREWS STARTING 6" FROM ENDS,
USE PAIRS OF FASTENERS (3" APART) AT 24" O.C. (1 1/4" EMBEDMENT)

2 X 6 VERTICAL JAMB ATTACHMENT TO GROUTED C-90 BLOCK (2000 PSI GROUT)

HILTI SLEEVE ANCHOR 3/8" X 2-3/4" STARTING 6" FROM ENDS
THEN 24" O.C. (1 1/4" EMBEDMENT)

(OR, USE FASTENERS FOR HOLLOW C-90 BLOCK)

*LAGS AND BOLTS CAN BE COUNTERSUNK TO PROVIDE A FLUSH MOUNTING SURFACE.

*PREPARATION OF WOOD JAMBS BY OTHERS

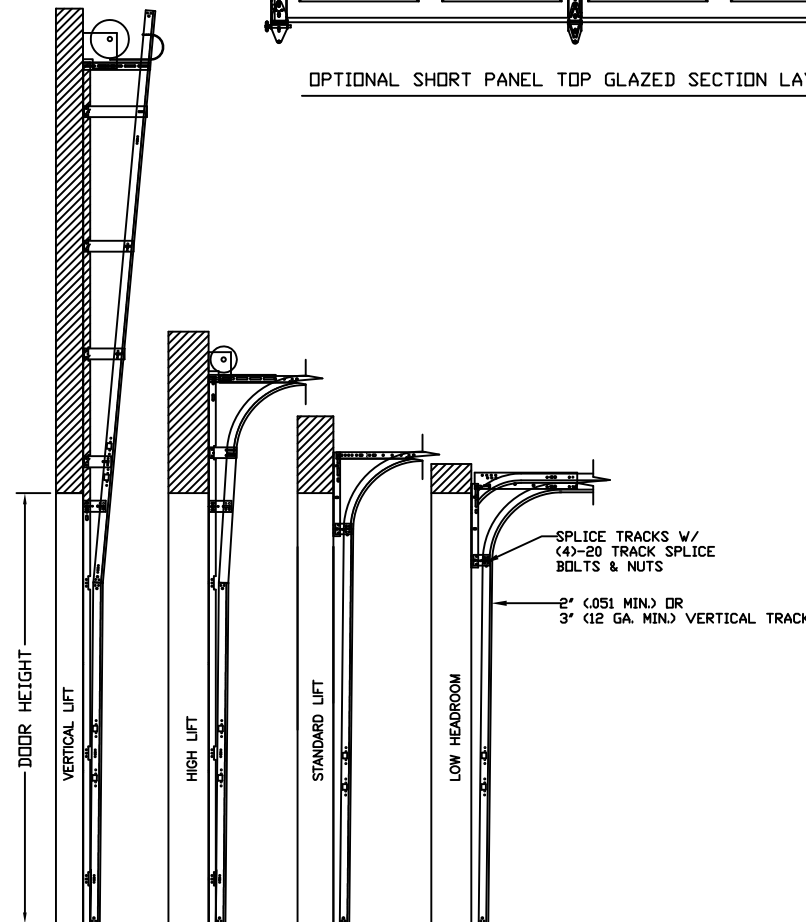
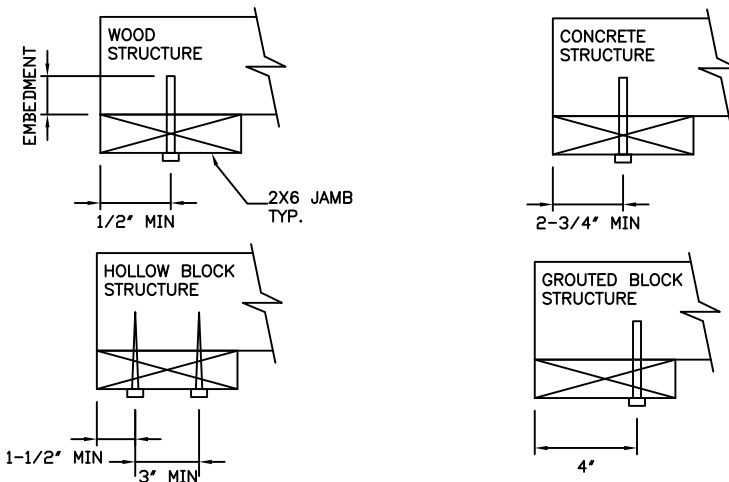

AVAILABLE TRACK CONFIGURATIONS
N.T.S.

REV	DESCRIPTION OF REVISIONS	DATE	BY
	MAX SIZE 9' x 14' DESIGN LOADS +22.8 PSF -26.9 PSF TEST LOADS +34.2 PSF -40.4 PSF		
	<p>This document has been digitally signed & sealed by Thomas L. Shelmerdine, PE on the date shown. Printed copies of this document are not considered signed & sealed, and the signature must be verified on any electronic copies.</p>		
	Thomas L. Shelmerdine, PE (TX PE #85829) Structural Solutions, PA (TX Firm #F-004063) 5921-G W. Friendly Ave., Greensboro, NC 27410		



MODEL #625 AMARR LINCOLN 1000, 2000
MODEL #675 AMARR HILLCREST 1000, 2000

SIZE	DRAWN BY	DRC	DATE	DRAWING NUMBER
B	CHECKED BY	DLJ	DATE 12/31/19	IRC-6209-120-15
AMARR COMPANY 165 CARRIAGE COURT WINSTON-SALEM, N.C. 27105				SHEET 2 OF 3

TABLE 1

DOOR HEIGHT	SECTION HEIGHTS							
	Btm	#2	#3	#4	#5	#6	#7	#8
14' 0"	21"	21"	21"	21"	21"	21"	21"	21"
13' 6"	21"	21"	21"	21"	21"	18"	18"	21"
13' 0"	21"	21"	21"	18"	18"	18"	18"	21"
12' 6"	21"	18"	18"	18"	18"	18"	18"	21"
12' 0"	21"	21"	21"	21"	21"	18"	21"	
11' 6"	21"	21"	21"	18"	18"	18"	21"	
11' 0"	21"	18"	18"	18"	18"	18"	21"	
10' 6"	21"	21"	21"	21"	21"	21"		
10' 0"	21"	21"	21"	18"	18"	21"		
9' 6"	21"	18"	18"	18"	18"	21"		
9' 0"	18"	18"	18"	18"	18"	18"		
8' 6"	21"	21"	21"	18"	21"			
8' 0"	21"	18"	18"	18"	21"			
7' 6"	18"	18"	18"	18"	18"			
7' 0"	21"	21"	21"	21"				
6' 6"	21"	18"	18"	21"				

TABLE 3

Section Width (ft)	Panel Type	Center Stile Location (Measured from Left Edge)	Max Design Loads Allowed	
			Positive (PSF)	Negative (PSF)
8' 0"	Short, Hillcrest	48.000	25.6	30.2
8' 0"	Long	48.000	25.6	30.2
8' 2"	Short, Hillcrest	49.000	25.1	29.6
8' 2"	Long	49.000	25.1	29.6
8' 4"	Short, Hillcrest	50.000	24.6	29.0
8' 4"	Long	50.000	24.6	29.0
8' 6"	Short, Hillcrest	51.000	24.1	28.4
8' 6"	Long	51.000	24.1	28.4
8' 8"	Short, Hillcrest	52.000	23.6	27.9
8' 8"	Long	52.000	23.6	27.9
8' 10"	Short, Hillcrest	53.000	23.2	27.4
8' 10"	Long	53.000	23.2	27.4
9' 0"	Short, Hillcrest	54.000	22.8	26.9
9' 0"	Long	54.000	22.8	26.9

TABLE 2

HEIGHT	TRACK ATTACHMENT							SPLICE
	A	B	C	D	E	F	G	
6' 0"	10"	38"	58"					64"
6' 6"	10"	38"	58"					70"
7' 0"	10"	38"	58"					76"
7' 6"	10"	38"	58"					82"
8' 0"	10"	38"	58"	82"				88"
8' 6"	10"	38"	58"	82"				94"
9' 0"	10"	38"	58"	82"				100"
9' 6"	10"	38"	58"	82"				106"
10' 0"	10"	38"	58"	82"	106"			112"
10' 6"	10"	38"	58"	82"	106"			118"
11' 0"	10"	38"	58"	82"	106"			124"
11' 6"	10"	38"	58"	82"	106"			130"
12' 0"	10"	38"	58"	82"	106"	130"		136"
12' 6"	10"	38"	58"	82"	106"	130"		142"
13' 0"	10"	38"	58"	82"	106"	130"		148"
13' 6"	10"	38"	58"	82"	106"	130"		154"
14' 0"	10"	38"	58"	82"	106"	130"	154"	160"

TABLE 4

SECTION	STRUT SIZE
TOP	2"
7TH	3"
6TH	3"
5TH	3"
4TH	3"
3RD	3"
2ND	3"
BOTTOM	3"
	2"

ALL TRACK ATTACHMENT SPACING +/- 2" ALLOWED WITH SYP OR SPF NO. 2 OR BETTER ONLY

REV	DESCRIPTION OF REVISIONS	DATE	BY

MAX SIZE
9' x 14'

DESIGN LOADS
+22.8 PSF
-26.9 PSF

TEST LOADS
+34.2 PSF
-40.4 PSF

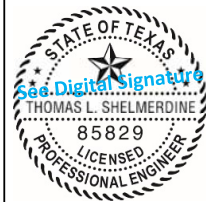

This document has been digitally signed & sealed by Thomas L. Shelmerdine, PE on the date shown. Printed copies of this document are not considered signed & sealed, and the signature must be verified on any electronic copies.

Thomas L. Shelmerdine, PE (TX PE #85829)
Structural Solutions, PA (TX Firm #F-004063)
5921-G W. Friendly Ave., Greensboro, NC 27410

TX



MODEL #625 AMARR LINCOLN 1000, 2000
MODEL #675 AMARR HILLCREST 1000, 2000

SIZE	DRAWN BY	DRC	DATE	12/19/19	DRAWING NUMBER
B	CHECKED BY	DLJ	DATE	12/31/19	IRC-6209-120-15
AMARR COMPANY 165 CARRIAGE COURT WINSTON-SALEM, N.C. 27105					SHEET 3 OF 3