

TOP FIXTURE REINFORCEMENT ILLUSTRATION

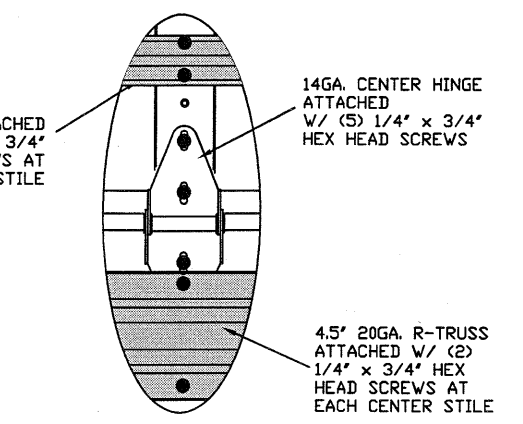

TYPICAL CENTER HINGE (2) N.T.S.

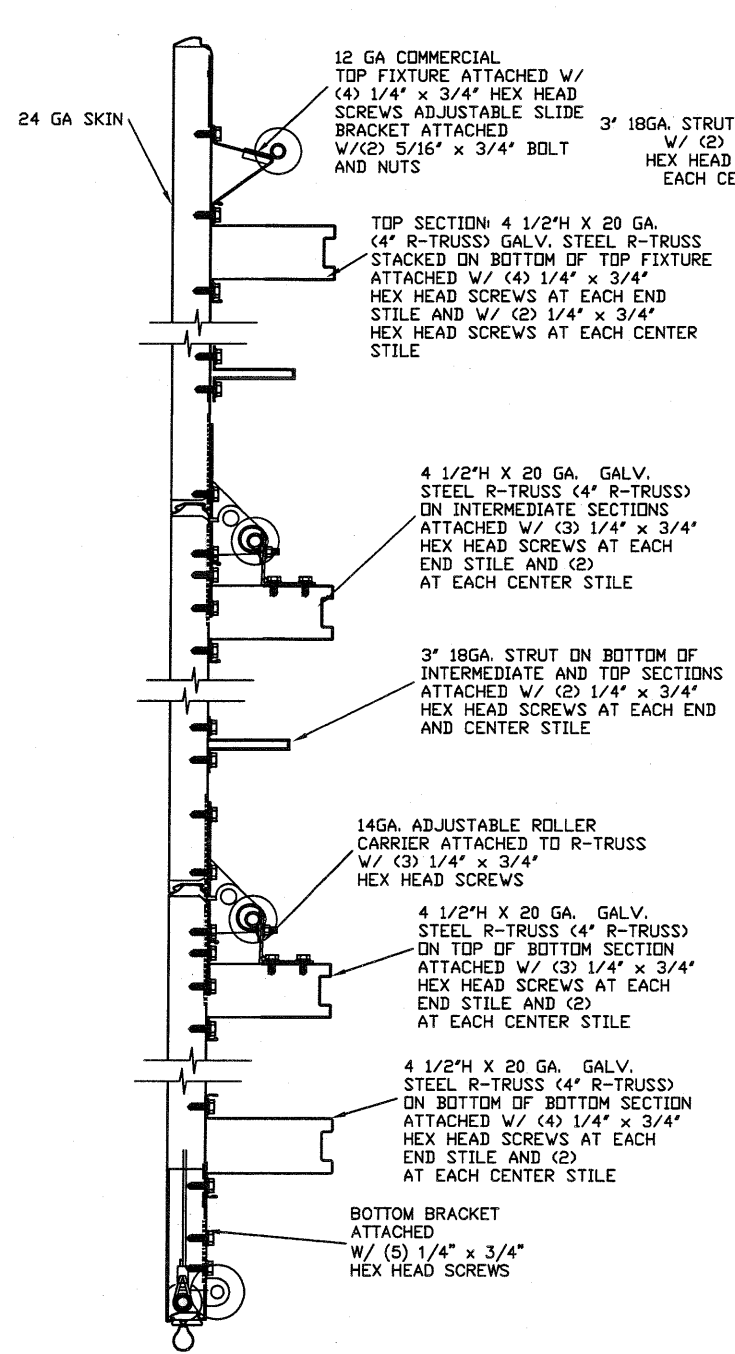
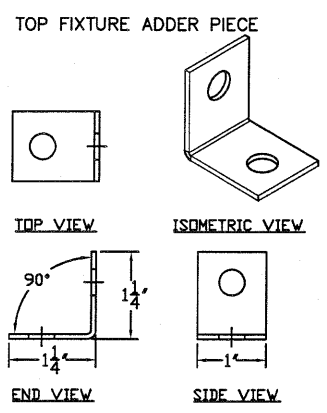
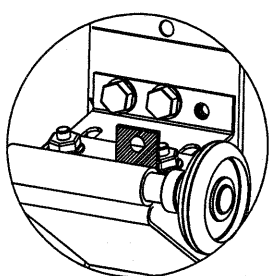
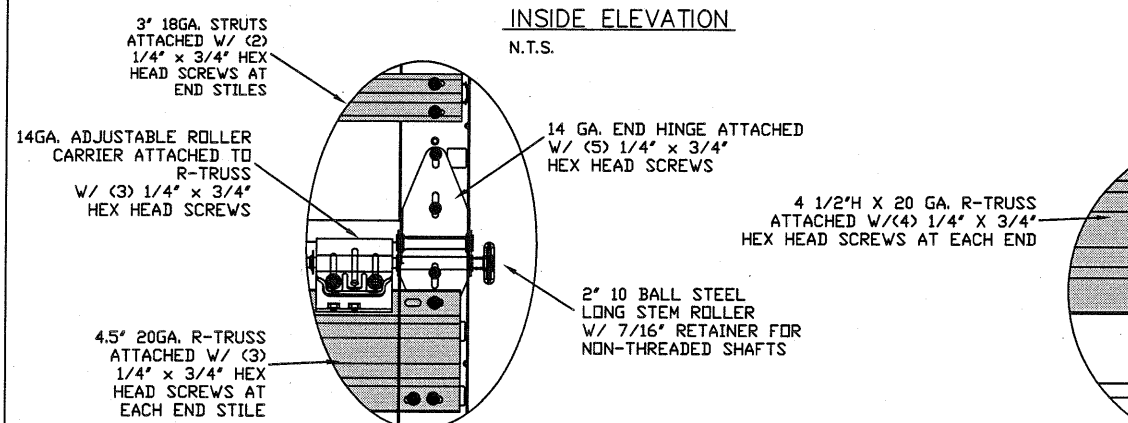

TYPICAL END HINGE (3) N.T.S.

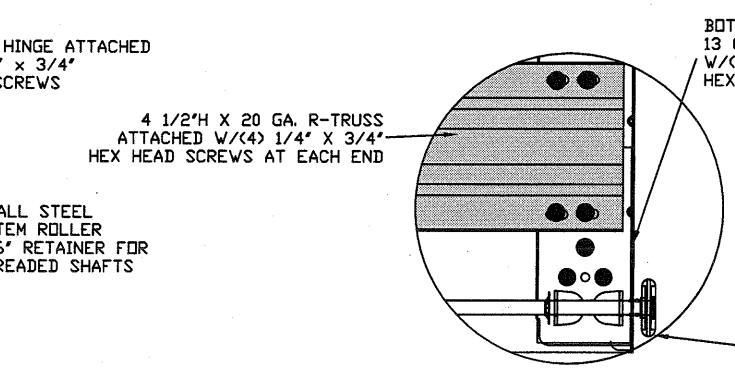

TYPICAL BOTTOM BRACKET (4) N.T.S.

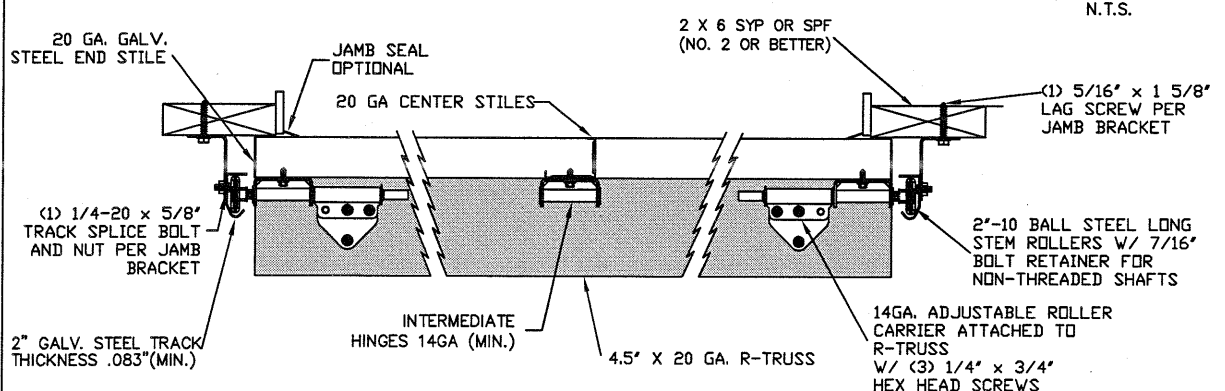

TRACK MOUNTING DETAIL N.T.S.

THE METHOD OF TESTING WAS IN SUBSTANTIAL CONFORMANCE WITH THE PROCEDURE DESCRIBED IN DASMA 108. THE PRESSURES SHOWN ON THE DRAWINGS WERE CALCULATED USING ASCE 7-16 WITH THE FOLLOWING PARAMETERS (2 FEET OF DOOR WIDTH IN THE END ZONE, ROOF AT ANY SLOPE):

WIND SPEED (MPH)	168	152	145	138	133
EXPOSURE LEVEL	B	C	C	D	D
MEAN ROOF HEIGHT	30'	15'	25'	15'	25'

REV	DESCRIPTION OF REVISIONS	DATE	BY

MAX SIZE
16' x 14'

DESIGN LOADS
+25.3 PSF
-28.8 PSF

TEST LOADS
(1.5 x DESIGN LOADS)
+38.0 PSF
-42.4 PSF

Thomas L. Shelmerdine, PE (TX PE #85829)
Structural Solutions, PA (TX Firm #F-004063)

TX

5921-G W. Friendly Ave., Greensboro, NC 27410

Amarr

MODEL #500
AMARR CLASSICA 1000, 2000

SIZE	DRAWN BY DLJ	DATE 06/26/2020	DRAWING NUMBER
B	CHECKED BY RLR	DATE 06/30/2020	IRC-5316-130-24

AMARR COMPANY
165 CARRIAGE COURT WINSTON-SALEM, N.C. 27105

SHEET 1 OF 3

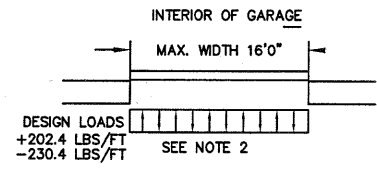

SPECIFICATIONS AND NOTES

1. ALL THE LOAD FROM THE DOOR IS TRANSFERRED TO THE VERTICAL TRACK, FROM THE TRACK THE LOAD IS TRANSFERRED TO THE VERTICAL JAMBS. THE HORIZONTAL JAMB OR HEADER RECEIVES NO PORTION OF THE LOAD TRANSFERRED FROM THE DOOR.
2. EACH VERTICAL JAMBS RECEIVES MAXIMUM DESIGN LOADS OF: +202.4 LBS/FT & -230.4 LBS/FT
3. DOORS AND HARDWARE WILL BE DESIGNED, MANUFACTURED AND INSTALLED WITH STANDARDS AS SET FORTH BY DASMA.
4. DOOR SECTIONS SHALL BE 24 GA. MIN. (.022") ROLLED FORMED LIGHT COMMERCIAL QUALITY
5. SUPPORTING STRUCTURAL ELEMENTS SHALL BE DESIGNED BY A REGISTERED PROFESSIONAL ENGINEER FOR WIND LOADS INDICATED ON THIS DRAWING IN ADDITION TO OTHER LOADINGS.
6. REFER TO TABLE 1 ON PAGE 3 FOR STRUT SCHEDULE
7. DOOR IS MANUFACTURED AND TESTED IN ACCORDANCE WITH THE 2018 IRC/IBC

WOOD JAMB ATTACHMENT TO STRUCTURE

2 X 6 VERTICAL JAMB ATTACHMENT TO WOOD FRAME STRUCTURE
 5/16" X 3" LAG SCREWS STARTING 6" FROM ENDS THEN 24" O.C. (1 1/2" EMBEDMENT)

2 X 6 VERTICAL JAMB ATTACHMENT TO 2,000 PSI CONCRETE
 HILTI KWIK BOLT 3/8" X 4" STARTING 6" FROM ENDS THEN 24" O.C. (2 1/2" EMBEDMENT)
 HILTI SLEEVE ANCHOR 3/8" X 2-3/4" STARTING 6" FROM ENDS THEN 22" O.C. (1 1/4" EMBEDMENT)
 ITW/RAMSET REDHEAD (TRU-BOLT) 3/8" X 4" STARTING 6" FROM ENDS THEN 24" O.C. (2 1/2" EMBEDMENT)

2 X 6 VERTICAL JAMB ATTACHMENT TO HOLLOW C-90 BLOCK
 SIMPSON 1/4" X 3" TITEN SCREWS STARTING 6" FROM ENDS, USE PAIRS OF FASTENERS (3' APART) AT 16" O.C. (1 1/2" EMBEDMENT)
 HILTI 1/4" X 2-3/4" KWIK-CON II+ SCREWS STARTING 6" FROM ENDS, USE PAIRS OF FASTENERS (3' APART) AT 16" O.C. (1 1/4" EMBEDMENT)

2 X 6 VERTICAL JAMB ATTACHMENT TO GROUTED C-90 BLOCK (2000 PSI GROUT)
 HILTI SLEEVE ANCHOR 3/8" X 2-3/4" STARTING 6" FROM ENDS THEN 24" O.C. (1 1/4" EMBEDMENT) (OR, USE FASTENERS FOR HOLLOW C-90 BLOCK)

*LAGS AND BOLTS CAN BE COUNTERSUNK TO PROVIDE A FLUSH MOUNTING SURFACE.
 *PREPARATION OF WOOD JAMBS BY OTHERS

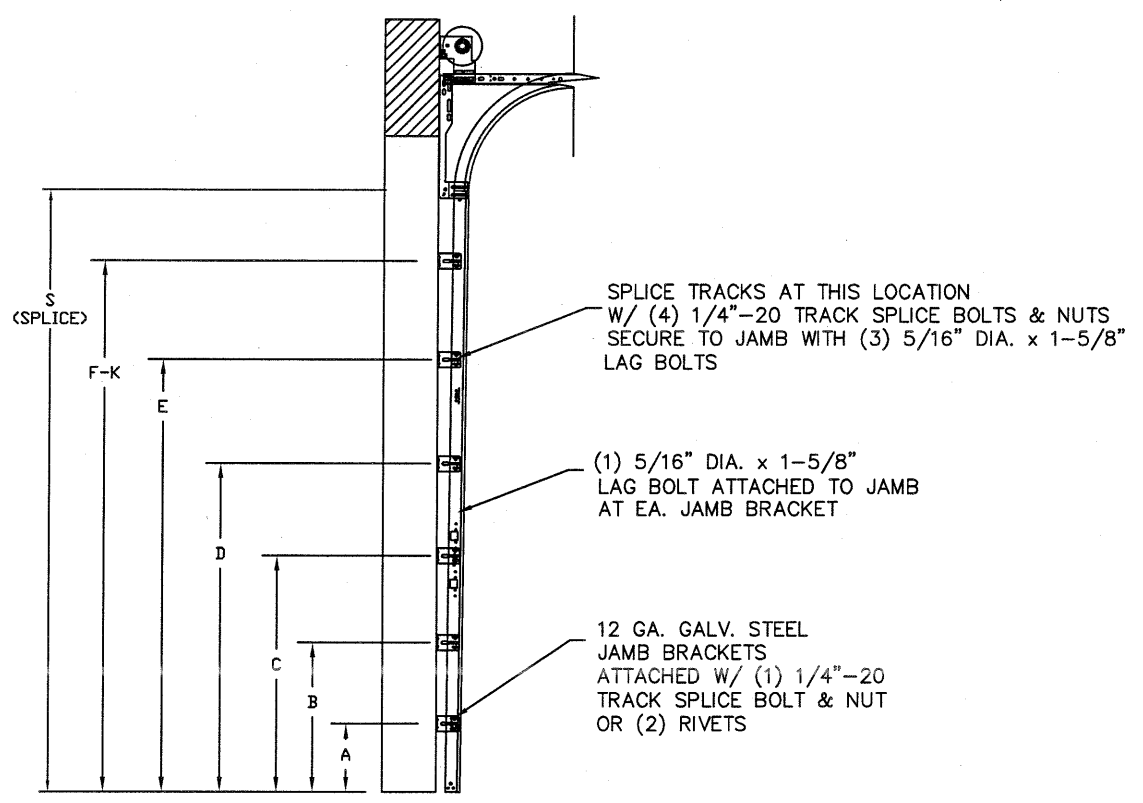

TRACK CONFIGURATION FOR 8' TALL DOORS
 N.T.S SEE TABLE 2 PAGE 3

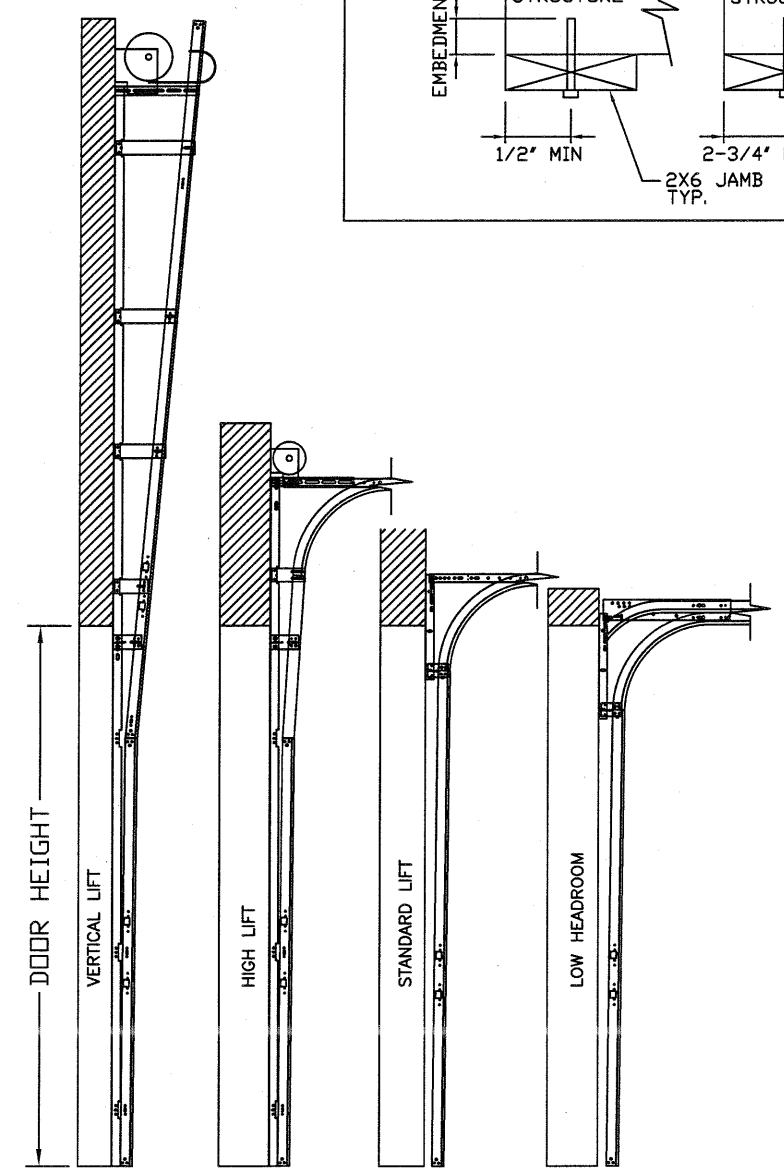

AVAILABLE TRACK CONFIGURATIONS
 N.T.S.

REV	DESCRIPTION OF REVISIONS	DATE	BY

MAX SIZE
 16' x 14'

DESIGN LOADS
 +25.3 PSF
 -28.8 PSF

TEST LOADS
 (1.5 x DESIGN LOADS)
 +38.0 PSF
 -42.4 PSF

Thomas L. Shelmerdine, PE (TX PE #85829)
 Structural Solutions, PA (TX Firm #F-004063)

STATE OF TEXAS
 THOMAS L. SHELMERDINE
 85829
 LICENSED PROFESSIONAL ENGINEER
 TX

5921-G W. Friendly Ave., Greensboro, NC 27410

Amarr

MODEL #500
 AMARR CLASSICA 1000, 2000

SIZE	DRAWN BY	DLJ	DATE	06/26/2020	DRAWING NUMBER
B	CHECKED BY	RLR	DATE	06/30/2020	IRC-5316-130-24

AMARR COMPANY
 165 CARRIAGE COURT WINSTON-SALEM, N.C. 27105

SHEET 2 OF 3

TABLE 1

SECTION	STRUT SIZE
TOP	4.5"
	3"
5TH	4.5"
	3"
4TH	4.5"
	3"
3RD	4.5"
	3"
2ND	4.5"
	3"
BOTTOM	4.5"
	4.5"

TABLE 3

Section	Non Glazed Center Stile Locations (Measured from Left Edge)					Max Design Loads Allowed	
	Width (ft)	1st (in)	2st (in)	3rd (in)	4th (in)	5th (in)	Positive (PSF)
12' 0	24.625	48.3125	72	95.688	119.38	25.5	28.5
15' 6	47.42	70.208	93.00	115.79	138.58	26.0	29.1
15' 8	48.02	71.008	94.00	116.99	139.98	25.7	28.8
15' 10	48.62	71.808	95.00	118.19	141.38	25.4	28.5
16' 0	48.42	72.208	96.00	119.79	143.58	25.3	28.3

SHADED BOXES INDICATE HINGE LOCATIONS
CONTACT ENGINEERING FOR SIZES NOT LISTED

TABLE 2

DOOR HEIGHT	TRACK ATTACHMENT											
	A	B	C	D	E	F	G	H	I	J	K	L
7' 0	10"	22"	34"	46"	58"							
7' 6	10"	22"	34"	46"	58"	70"						
8' 0	10"	22"	34"	46"	58"	70"						
8' 6	10"	22"	34"	46"	58"	70"	82"					
9' 0	10"	22"	34"	46"	58"	70"	82"					
9' 6	10"	22"	34"	46"	58"	70"	82"	94"				
10' 0	10"	22"	34"	46"	58"	70"	82"	94"				
11' 0	10"	22"	34"	46"	58"	70"	82"	94"	106"			
12' 0	10"	22"	34"	46"	58"	70"	82"	94"	106"	118"		
13' 0	10"	22"	34"	46"	58"	70"	82"	94"	106"	118"	130"	
14' 0	10"	22"	34"	46"	58"	70"	82"	94"	106"	118"	130"	142"

ALL TRACK AND ATTACHMENT SPACING +/-2" ALLOWED WITH SYP OR SPF NO. 2 OR BETTER ONLY

REV	DESCRIPTION OF REVISIONS	DATE	BY

MAX SIZE
16' x 14'

DESIGN LOADS
+25.3 PSF
-28.8 PSF

TEST LOADS
(1.5 x DESIGN LOADS)
+38.0 PSF
-42.4 PSF

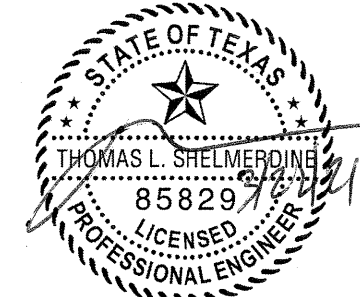

THOMAS L. SHELME RDINE
85829
LICENSED PROFESSIONAL ENGINEER

Thomas L. Shelmerdine, PE (TX PE #85829)
Structural Solutions, PA (TX Firm #F-004063)

5921-G.W. Friendly Ave., Greensboro, NC 27410

TX



MODEL #500
AMARR CLASSICA 1000, 2000

SIZE	DRAWN BY	DLJ	DATE	06/26/2020	DRAWING NUMBER
B	CHECKED BY	RLR	DATE	06/30/2020	IRC-5316-130-24

AMARR COMPANY
165 CARRIAGE COURT WINSTON-SALEM, N.C. 27105

SHEET 3 OF 3