

Door Width 16' - 2" Shown  
See chart below for other door widths

SEE SHEET 3 OF 4 FOR GLAZING DETAIL AND IMPACT LITE OPTIONS.

NOTE: Track configuration above the door opening does not affect the wind load rating of the door.

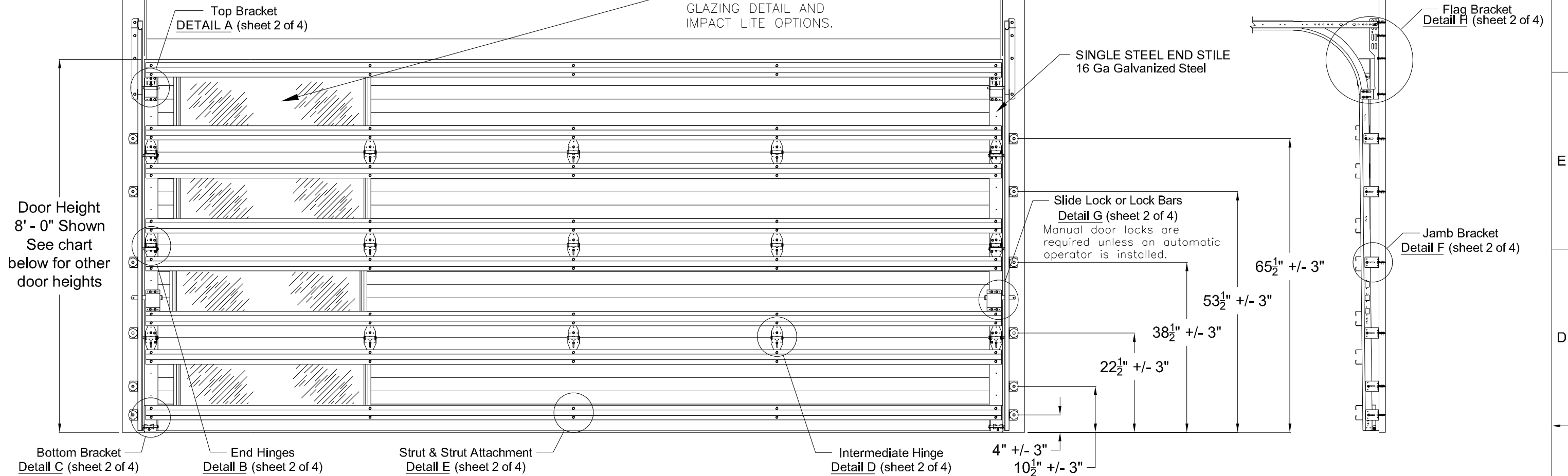

This product has been evaluated per ANSI/DASMA 108 for static air pressure.

This product has been evaluated per ANSI/DASMA 115 for large missile impact and cyclic wind pressure.

Model Number	
HT_10 & 2_10 SERIES	
HT_12 & 2_12 SERIES	
HT_32 & 2_32 SERIES	
HT_33 & 2_33 SERIES	

Door Widths Up To	Design Pressures		End Backers	Minimum Center		Impact Resistant
	+ psf	- psf		Stiles	Hinges	
12'-2"	38.0	-42.0	Single	2	2	YES
14'-2"	38.0	-42.0	Single	4	4	YES
16'-2"	38.0	-42.0	Single	3	3	YES

This product is available in narrower sizes with the same PSF and constructed as shown.

This product is designed and sold by PSF. The AHJ or Engineer of Record is responsible for determining the PSF required for any given site.

Jamb bracket quantities shown are for use with grade 2 or better southern pine jambs. Supporting structural elements are to be designed by a registered professional engineer for specific wind loads.

Door Height	Total No. of Sections	Total # of Struts (When lite section is the top section, if not see the notice at the right)	Jamb Brkts/Side
6'-0"	3	6	5
6'-0"	4	8	5
6'-3"	4	8	5
6'-6"	4	8	6
6'-9"	4	8	6
7'-0"	4	8	6
7'-3"	4	8	6
7'-6"	4	8	6
7'-6"	5	10	6
7'-9"	4	8	6
7'-9"	5	10	6
8'-0"	4	8	6
8'-0"	5	10	6

Maximum section height is 24 in.  
Maximum door height is 20 ft.

All doors, even those above the tested height, are available with jamb brackets or commercial full angle. The maximum spacing of the jamb brackets/track clips should be maintained.

**NOTICE:**

These drawings are a supplement to the installation instructions for a standard door and only covers those procedures that vary from standard door installation. If these specific procedures are not followed, the door may not perform as designed.

**NOTICE:**

The only lite configurations available per section are shown on sheet 3 of 4. These configurations can be placed at different locations in the section. The lite sections of this door may be replaced with a solid section. In all cases the strut and stile configuration should remain the same.

**IMPACT RESISTANT**

COMPLIES WITH IBC/IRC 2018

Professional Engineer seal provided only for verification of wind load construction details.

John E. Scates, P.E.  
2560 King Arthur Blvd. Ste 124-54  
Lewisville, Texas 75056  
Texas P.E. 56308/F2203



DESCRIPTION:			
16' 2" HT 600, 700 & 2000 SERIES W/IMPACT RESISTANT LITES WIND LOAD SECTIONAL DOOR DESIGN PRESSURE +38.0/-42.0 PSF			
DRAWING NO.:	WLTl-0600-0194-08-38-42L1	REV.	A
DRAWN BY:	MVS	DATE DRAWN:	10/25/18
MODEL(S):	See Sheet 3	REV. DATE:	3/1/22
			SHEET: 1 OF 4

320 Sycamore  
Wauseon, Ohio 43567  
© Copyright 2014

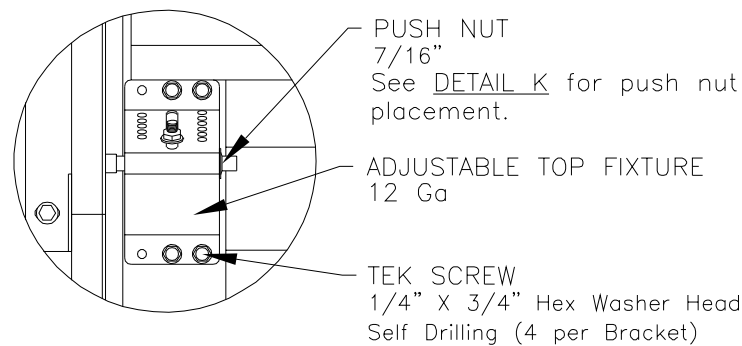

**DETAIL A**

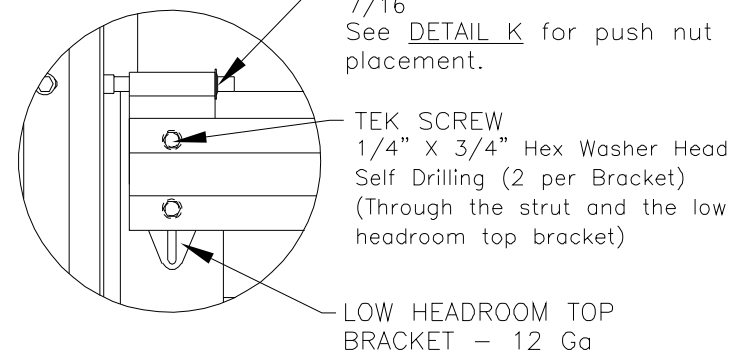

**LOW HEADROOM TOP BRACKET**

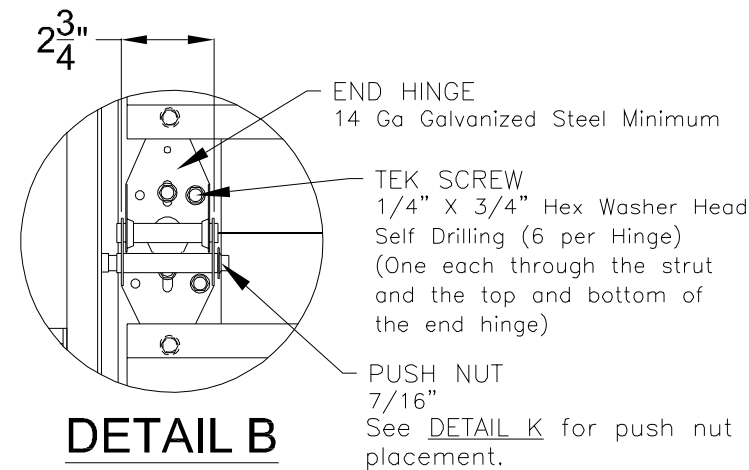

**DETAIL B**

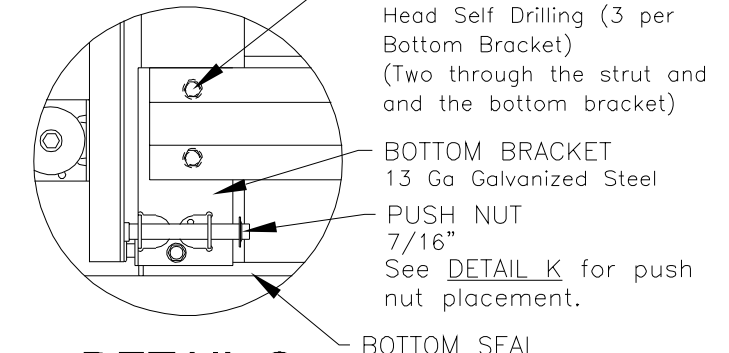

**DETAIL C**

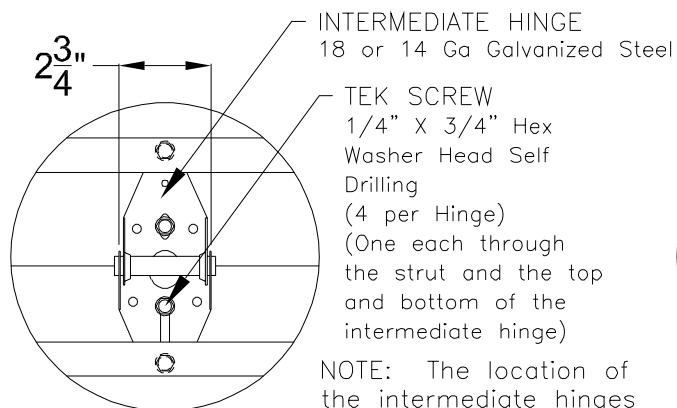

**DETAIL D**

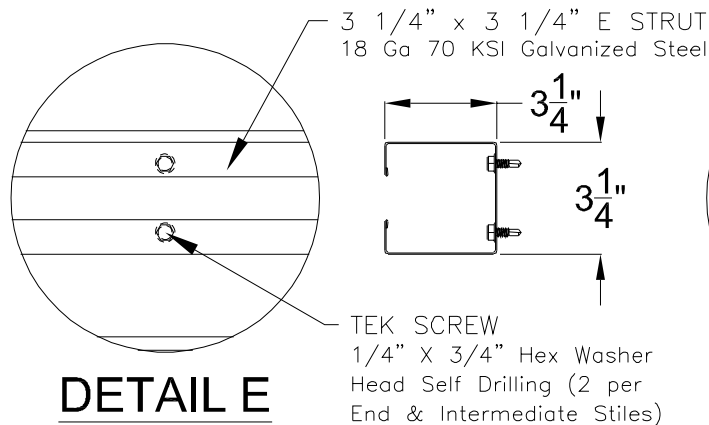

**DETAIL E**

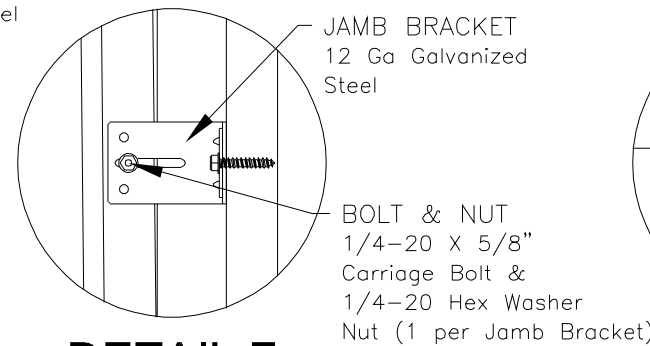

**DETAIL F**

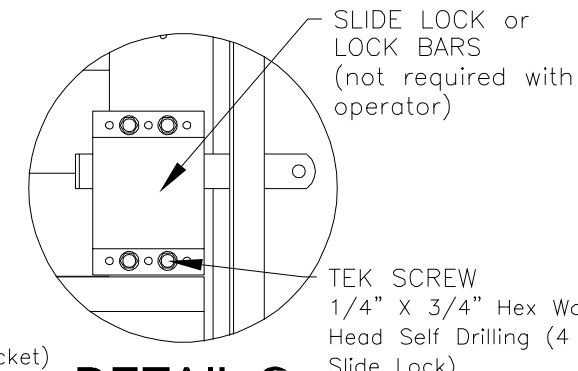

**DETAIL G**

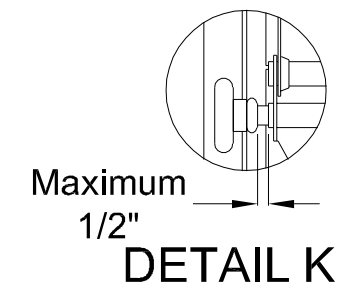

**Maximum 1/2\"**  
**DETAIL K**

NOTE: The location of the intermediate hinges is indicated by the toggle lock dimples at the top of each section.

NOTE: Details on some views omitted for clarity.

Double end stiles and end hardware may be provided on wider or heavier doors.

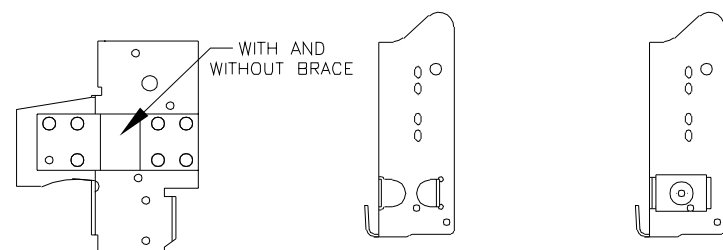

**RESIDENTIAL & LIGHT COMMERCIAL**  
For Low Headroom With 2\"

**COMMERCIAL**  
For Standard, High & Vertical Lift With 2\"

**COMMERCIAL**  
For Standard, High & Vertical Lift With 3\"

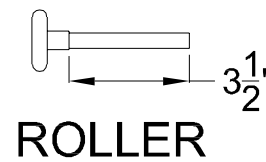

**ROLLER**

2\"

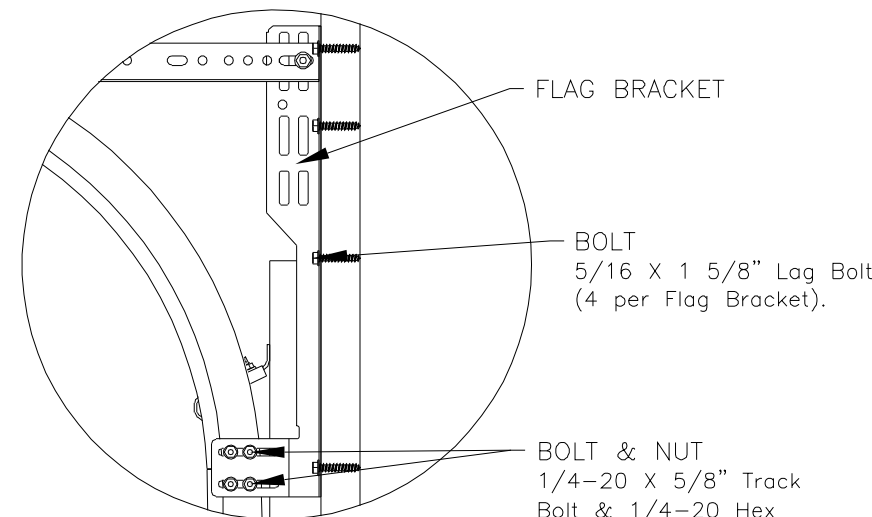

**DETAIL H**

FLAG BRACKET

BOLT  
5/16 X 1 5/8\"

BOLT & NUT  
1/4-20 X 5/8\"

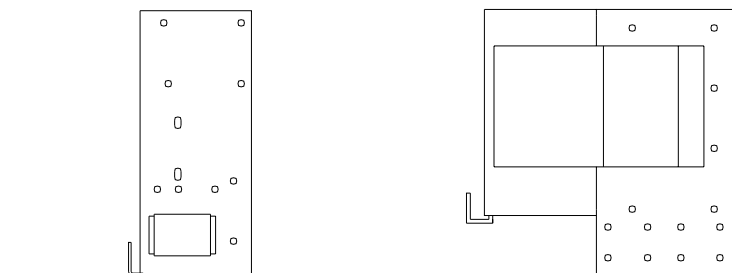

**COMMERCIAL HEAVY DUTY**  
For Standard, High & Vertical Lift With 3\"

**COMMERCIAL HEAVY DUTY**  
For Low Headroom With 3\"

**ALTERNATE BOTTOM BRACKETS**

NOTE: The bottom bracket tested (shown in DETAIL C) is the lightest bracket available.

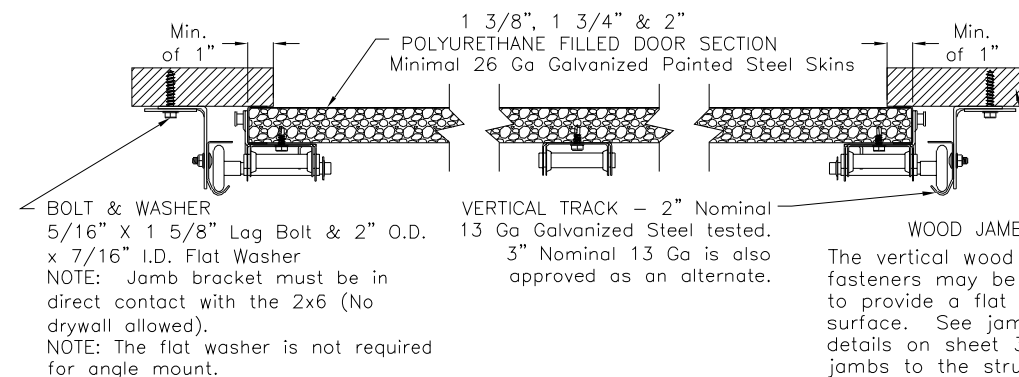

**IMPACT RESISTANT**

John E. Scates, P.E.  
2560 King Arthur Blvd. Ste 124-54  
Lewisville, Texas 75056  
Texas P.E. 56308/F2203

Professional Engineer seal provided only for verification of wind load construction details.



<b>DESCRIPTION:</b>			
16' 2" HT 600, 700 & 2000 SERIES W/IMPACT RESISTANT LITES WIND LOAD SECTIONAL DOOR DESIGN PRESSURE +38.0/-42.0 PSF			
<b>DRAWING NO.:</b> WLTI-0600-0194-08-38-42L1	<b>REV.:</b> A		
<b>DRAWN BY:</b> MVS	<b>DATE DRAWN:</b> 10/25/18	<b>REV. DATE:</b> 3/1/22	
<b>MODEL(S):</b> See Sheet 3	<b>SHEET: 2 OF 4</b>		

320 Sycamore  
Wauseon, Ohio 43567  
© Copyright 2014

The vertical wood jamb fasteners may be counter sunk to provide a flat mounting surface. See jamb attachment details on sheet 3 for attaching jambs to the structure.

VERTICAL TRACK - 2\"

BOLT & WASHER  
5/16\"

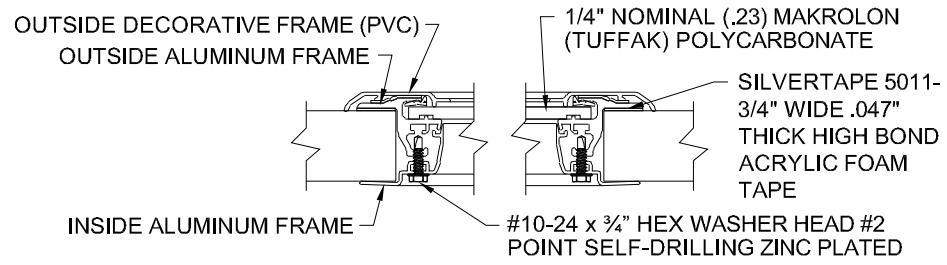
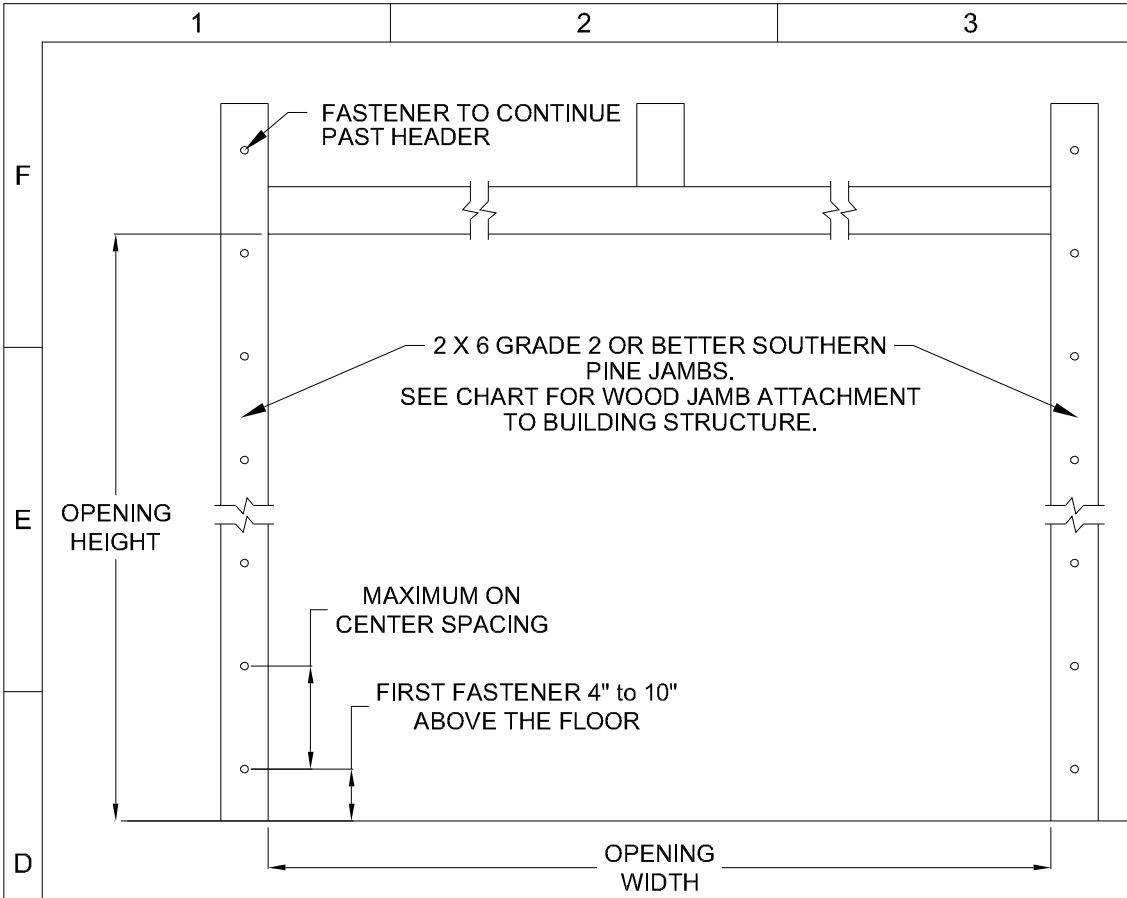

**GLAZING DETAIL**  
 NOTE: ALL GLAZING IS IMPACT RESISTANT MAKROLON (TUFFAK) GENERAL PURPOSE OR UV RESISTANT POLYCARBONATE WITH A 1/4 NOMINAL (.23) THICKNESS.

**MODEL NUMBERS AND LITE OPTIONS**

MODEL NUMBERS AVAILABLE	LITE OPTIONS AVAILABLE		
	CARRIAGE HOUSE	RANCH	STANDARD
HT_32 & 2_32 SERIES	X	X	X
HT_33 & 2_33 SERIES	X	X	X
HT_10 & 2_10SERIES	X	X	X
HT_12 & 2_12 SERIES	X	X	X
	38 1/2" x 12 5/8"	38 1/2" x 10 1/2"	17 1/4" x 10 1/4"
DAY LIGHT OPENING (DLO) - WIDE x TALL			

WOOD JAMB ATTACHMENT						
Building Structure	Fastener Type	Minimum Embedment	Minimum Edge Distance	Minimum on Center Spacing	Maximum on Center Spacing	Allowable Tension Load
Min. 2500 PSI to 4000 PSI Concrete	Tapcon + (PLUS) 1/4" w/ 1" OD washer	2"	2.50"	5.00"	21"	551
Southern Pine	3/8" Lag w/ 1 1/8" OD washer	1.50"	1.50"	1.50"	24"	620
Spruce Pine Fir	3/8" Lag w/ 1 1/8" OD washer	1.50"	1.50"	1.50"	18"	482

NOTE: 2X6 mounted to the wall must be Southern Pine Grade 2 or better.

**AVAILABLE LITE CONFIGURATIONS**

NOTE: THE LITE LOCATIONS BELOW ARE STANDARD FOR EACH LITE SIZE. THE LITES MAY BE LOCATED IN OTHER POSITIONS IN THE SECTIONS BUT THE NUMBER PER SECTION CANNOT BE MORE THAN SHOWN.

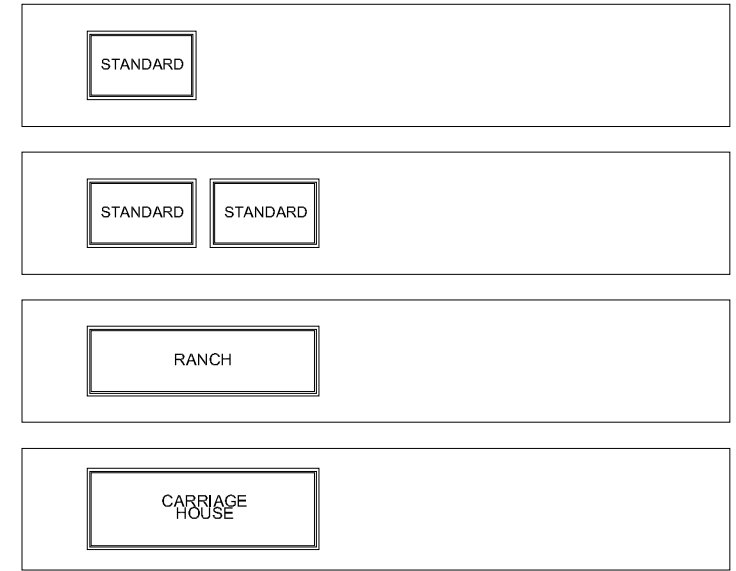

**IMPACT RESISTANT**

John E. Scates, P.E.  
 2560 King Arthur Blvd. Ste 124-54  
 Lewisville, Texas 75056  
 Texas P.E. 56308/F2203

Professional Engineer seal provided only for verification of wind load construction details.

	<b>DESCRIPTION:</b>		
	16' 2" HT 600, 700 & 2000 SERIES W/IMPACT RESISTANT LITES WIND LOAD SECTIONAL DOOR DESIGN PRESSURE +38.0/-42.0 PSF		
	<b>DRAWING NO.:</b> WLTI-0600-0194-08-38-42L1	<b>REV.:</b> A	
	<b>DRAWN BY:</b> MVS	<b>DATE DRAWN:</b> 10/25/18	<b>REV. DATE:</b> 3/1/22
<b>MODEL(S):</b> See Sheet 3		<b>SHEET: 3 OF 4</b>	

320 Sycamore  
 Wauseon, Ohio 43567  
 © Copyright 2014

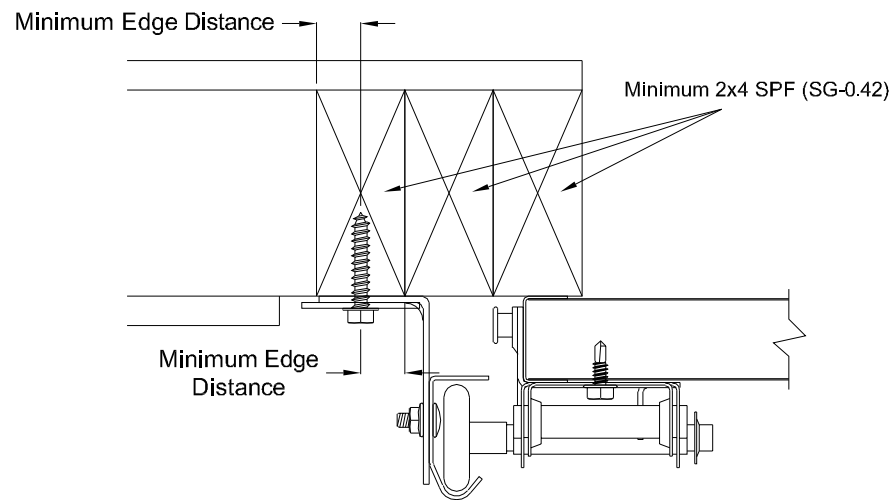

### Direct Wood Mounting Detail

Bracket Mount Shown, Reverse and Continuous Angle Mount Also Approved As Alternate.

439 lbs. per anchor allowable load

5/16" Dia. Lag Screw w/1-1/8" O.D. Flat Washer (shall conform to ANSI/ASME standard B18.2.1)

Minimum Screw Length: Spruce-Pine-Fur (SPF) - 2-1/2"  
Southern Pine - 1-5/8"

Minimum Edge Distance: 1/2"

Maximum on Center Spacing: 17"

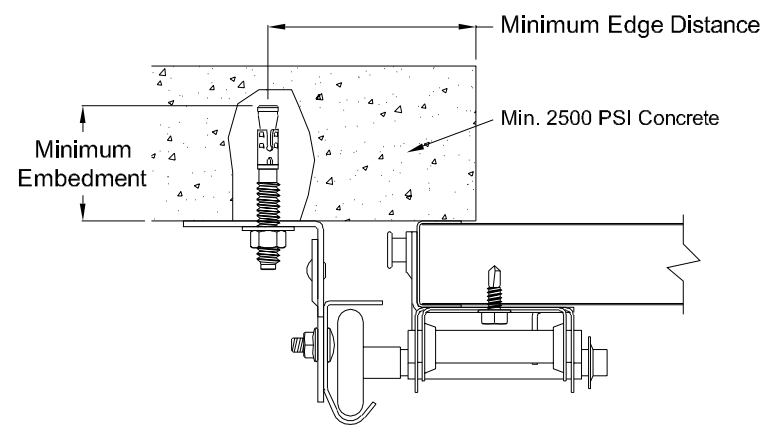

### Direct Concrete Mounting Detail

Continuous Angle Clip Mount Shown, Bracket and Reverse Continuous Angle Mount Also Approved As Alternate.

831 lbs. per anchor allowable load

3/8" Dia. Ankr-Tite CCAT w/1-1/8" O.D. Flat Washer (by Wej-It Fastening Systems)

Minimum Embedment: 2-5/8"

Minimum Edge Distance: 2-1/2"

Minimum on Center Spacing: 6"

Maximum on Center Spacing: 24"

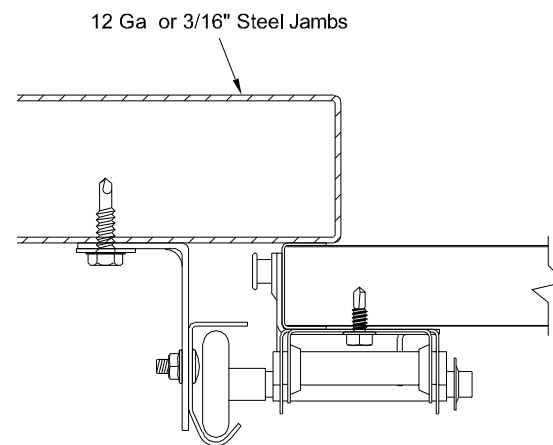

### Direct Steel Mounting Detail

Bracket Mount Shown, Reverse and Continuous Angle Mount Also Approved As Alternate.

232 lbs. per anchor allowable load - 12 Ga Ste569el

lbs. per anchor allowable load - 3/16" Ga Steel

5/16"-12 Tek Self-Drilling Screw w/9/16" O.D. Flat Washer

12 Ga Maximum on Center Spacing: 9"

3/16" Maximum on Center Spacing: 22"

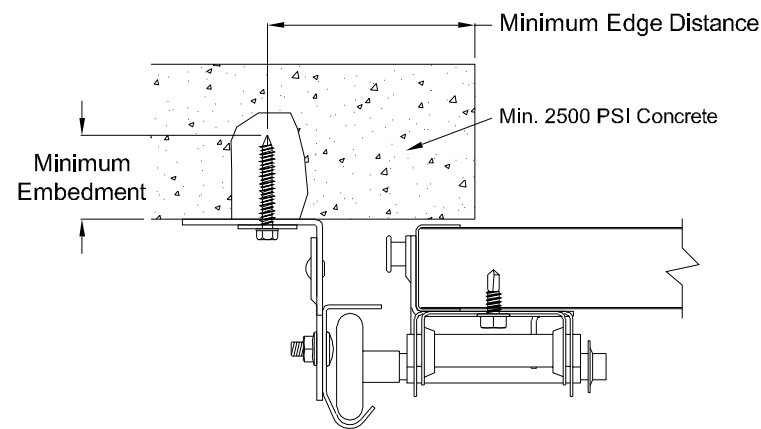

### Direct Concrete Mounting Detail

Continuous Angle Clip Mount Shown, Bracket and Reverse Continuous Angle Mount Also Approved As Alternate.

562 lbs. per anchor allowable load

1/4" Dia. Concrete Self-Tapping & Wedge Anchor w/1" O.D. Flat Washer (Includes Tapcon+ (by ITW),

Wedge-Bolt+ (by Powers Fasteners) & Red Head

TruBolt wedge anchor (by ITW))

Minimum Embedment: 2"

Minimum Edge Distance: 2-1/2"

Minimum on Center Spacing: 5"

Maximum on Center Spacing: 22"

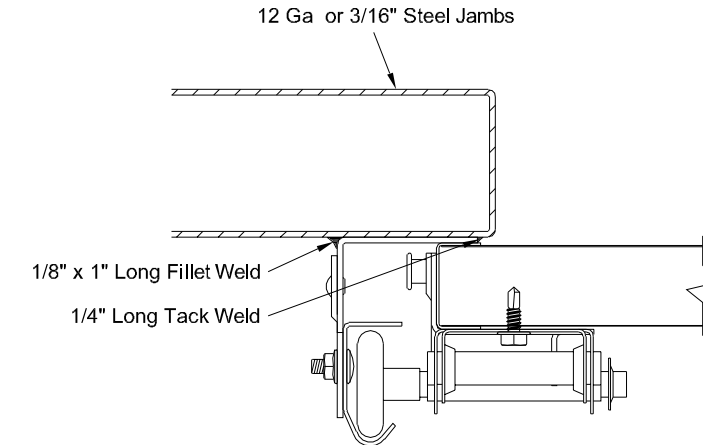

### Direct Steel Mounting Detail

Reverse Continuous Angle Clip Mount Shown, Continuous Angle Mount Also Approved As Alternate.

1272 lbs. per anchor allowable load

1/8" Nom. x 1" Long Fillet and 1/4" Long Tack Weld (E60xx Electrodes Min.)

Welds performed by a certified welder or inspected by a certified welding inspector to verify integrity of the welds.

Maximum on Center Spacing: Apply welds at each roller location not to exceed 24"

**IMPACT RESISTANT**

John E. Scates, P.E.  
2560 King Arthur Blvd. Ste 124-54  
Lewisville, Texas 75056  
Texas P.E. 56308/F2203

Professional Engineer seal provided only for verification of wind load construction details.



**DESCRIPTION:**  
16' 2" HT 600, 700 & 2000 SERIES W/IMPACT RESISTANT LITES WIND LOAD SECTIONAL DOOR DESIGN PRESSURE +38.0/-42.0 PSF

**DRAWING NO.:** WLTI-0600-0194-08-38-42L1 **REV.:** A

**DRAWN BY:** MVS **DATE DRAWN:** 10/25/18 **REV. DATE:** 3/1/22

**MODEL(S):** See Sheet 3 **SHEET: 4 OF 4**

320 Sycamore  
Wauseon, Ohio 43567  
© Copyright 2014