

NOTE: Track configuration above the door opening does not affect the wind load rating of the door.

Door Height 8'-0" Shown
See chart below for other door heights

Door Width 16'-2" Shown
See chart below for other door widths

This product has been evaluated per ANSI/DASMA 108 for static air pressure.
This product has been evaluated per ANSI/DASMA 115 for large missile impact and cyclic wind pressure.

Jamb bracket quantities shown are for use with grade 2 or better southern pine jambs. Supporting structural elements are to be designed by a registered professional engineer for specific wind loads.

| Model Number | |
|---------------------|---------------------|
| HT_60 & 2_60 SERIES | HT_10 & 2_10 SERIES |
| HT_61 & 2_61 SERIES | |
| HT_63 & 2_63 SERIES | |
| HT_64 & 2_64 SERIES | |
| HT_68 & 2_68 SERIES | |
| HT_69 & 2_69 SERIES | |
| HT_78 & 2_78 SERIES | |
| HT_79 & 2_79 SERIES | |
| HT_80 & 2_80 SERIES | |
| HT_81 & 2_81 SERIES | |
| HT_82 & 2_82 SERIES | |
| HT_90 & 2_90 SERIES | |

| Door Widths Up To | Design Pressures | | End Backers | Minimum Center | | Minimum Center | | Minimum Center | | Impact Resistant |
|-------------------|------------------|-------|-------------|----------------|--------|----------------|--------|----------------|--------|------------------|
| | + psf | - psf | | Stiles | Hinges | Stiles | Hinges | Stiles | Hinges | |
| 10'-2" | 31.3 | -34.9 | Single | 2 | 2 | 1 | 1 | 2 | 2 | YES |
| 12'-2" | 31.3 | -34.9 | Single | 2 | 2 | 2 | 2 | 2 | 2 | YES |
| 14'-2" | 31.3 | -34.9 | Single | 4 | 4 | 2 | 2 | 3 | 3 | YES |
| 16'-2" | 31.3 | -34.9 | Single | 3 | 3 | 3 | 3 | 3 | 3 | YES |

| Door Height | Total No. of Sections | Total # of Struts <small>(When lite section is the top section. If not see the notice at the right)</small> | Jamb Brkts/Side |
|-------------|-----------------------|--|-----------------|
| 6'-0" | 3 | 5 | 5 |
| 6'-0" | 4 | 6 | 5 |
| 6'-3" | 4 | 6 | 5 |
| 6'-6" | 4 | 6 | 6 |
| 6'-9" | 4 | 6 | 6 |
| 7'-0" | 4 | 6 | 6 |
| 7'-3" | 4 | 6 | 6 |
| 7'-6" | 4 | 6 | 6 |
| 7'-6" | 5 | 8 | 6 |
| 7'-9" | 4 | 6 | 6 |
| 7'-9" | 5 | 8 | 6 |
| 8'-0" | 4 | 6 | 6 |
| 8'-0" | 5 | 8 | 6 |

NOTICE: These drawings are a supplement to the installation instructions for a standard door and only covers those procedures that vary from standard door installation. If these specific procedures are not followed, the door may not perform as designed.

NOTICE: The lite section of this door may be replaced with a section with another lite style or a solid section. In either case the strut and stile configuration should remain the same.

NOTICE: Only one lite section per door is permitted. The lite section can be used anywhere except for the bottom section. If the lite section is not the top section then the struts must be located as shown in the STRUT CONFIGURATION on sheet 3 of 4.

John E. Scates, P.E.
2560 King Arthur Blvd. Ste 124-54
Lewisville, Texas 75056
Texas P.E. 56308/F2203

IMPACT RESISTANT

Maximum section height is 24 in.
Maximum door height is 20 ft.

COMPLIES WITH IBC/IRC 2018 Professional Engineer seal provided only for verification of wind load construction details.

This product is available in narrower sizes with the same PSF and constructed as shown.
This product is designed and sold by PSF. The AHJ or Engineer of Record is responsible for determining the PSF required for any given site.

All doors, even those above the tested height, are available with jamb brackets or commercial full angle. The maximum spacing of the jamb brackets/track clips should be maintained.

DESCRIPTION:
16" HT 600, 700, 2000 & 900/9000 AMERICAN TRADITION SERIES W/IMPACT RESISTANT LITES WIND LOAD SECTIONAL DOOR DESIGN PRESSURE +31.3/-34.9 PSF

DRAWING NO.: WLTl-0600-0194-08-31-35L **REV.:** A

DRAWN BY: MVS **DATE DRAWN:** 10/25/18 **REV. DATE:** 2/28/22

MODEL(S): See Sheet 3 **SHEET: 1 OF 4**

320 Sycamore
Wauseon, Ohio 43567
© Copyright 2014

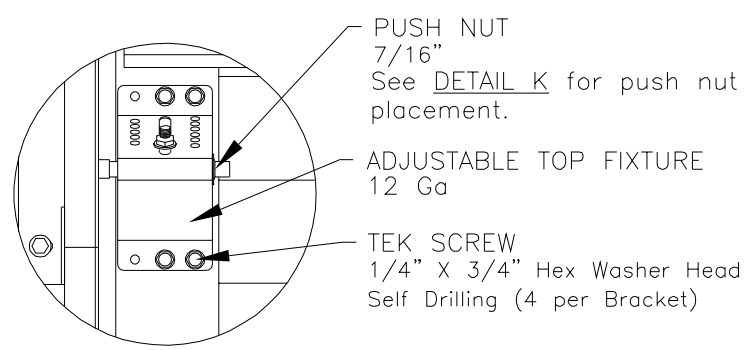

DETAIL A

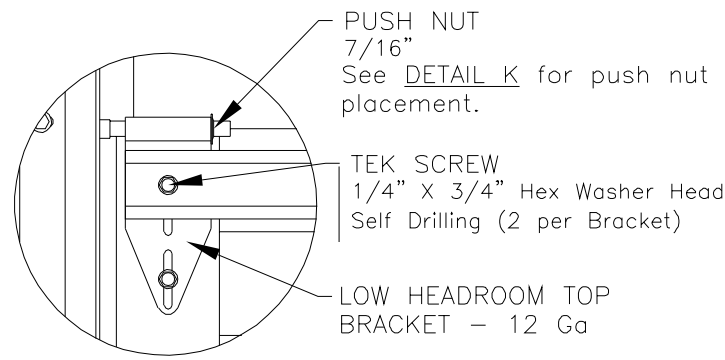

LOW HEADROOM TOP BRACKET

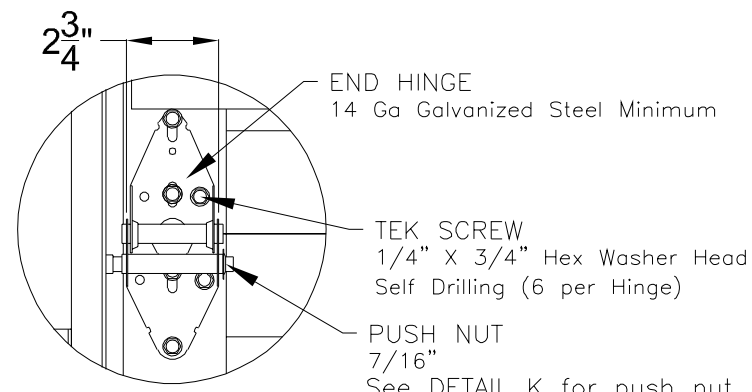

DETAIL B

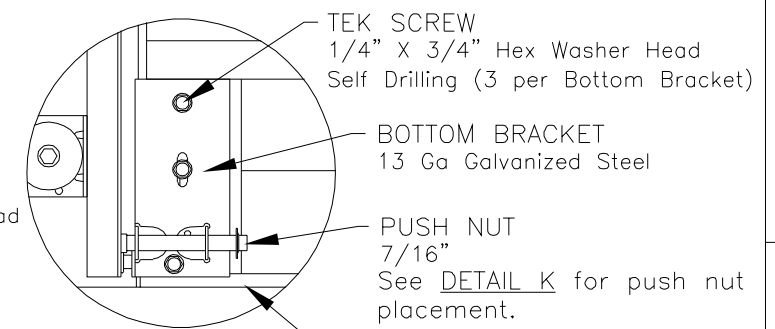

DETAIL C

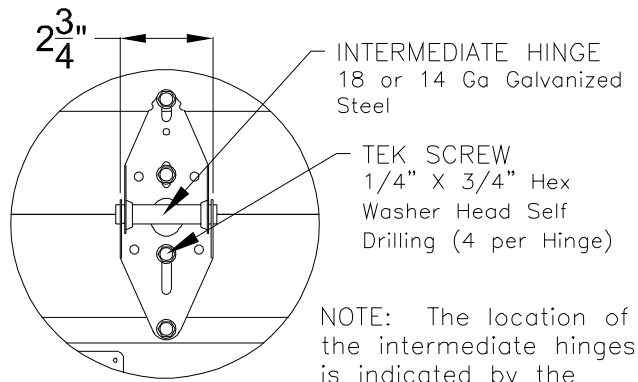

DETAIL D

NOTE: The location of the intermediate hinges is indicated by the toggle lock dimples at the top of each section.

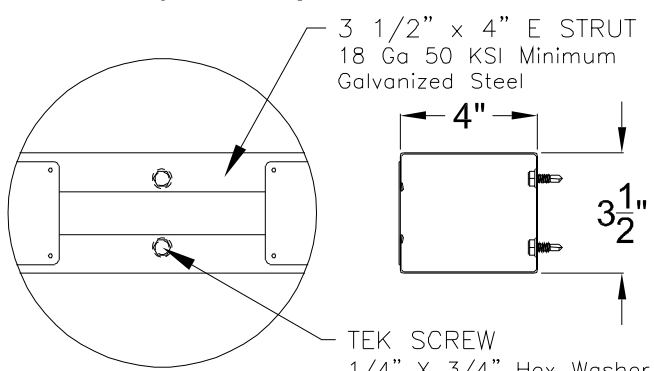

DETAIL E

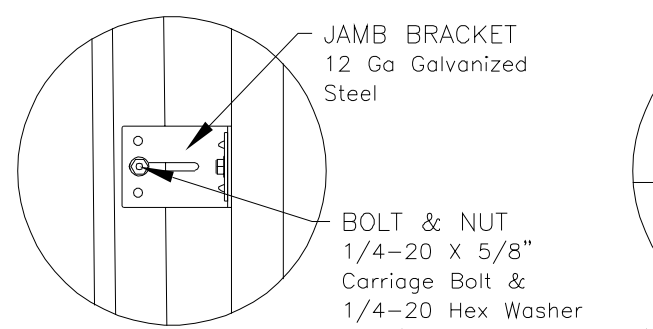

DETAIL F

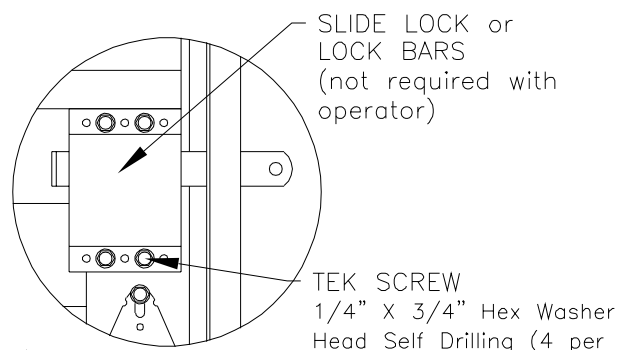

DETAIL G

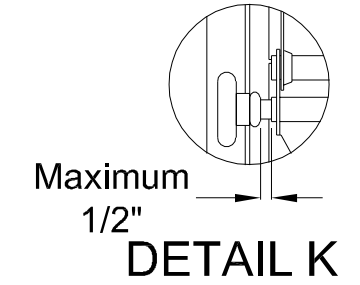

There should be a space of maximum 1/2" between the roller hub and the outside edge of the roller holder which is set by the push nut.

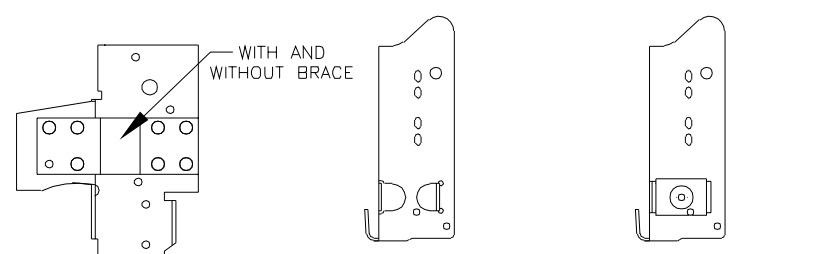

RESIDENTIAL & LIGHT COMMERCIAL
For Low Headroom With 2" Track and Single End Stiles

COMMERCIAL
For Standard, High & Vertical Lift With 2" Track and Single End Stiles

COMMERCIAL
For Standard, High & Vertical Lifts With 3" Track and Single End Stiles

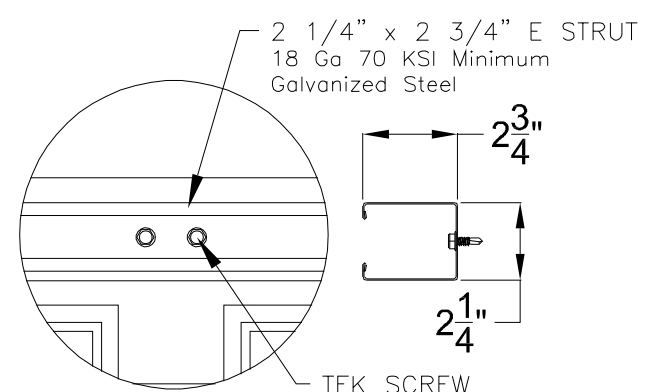

DETAIL J

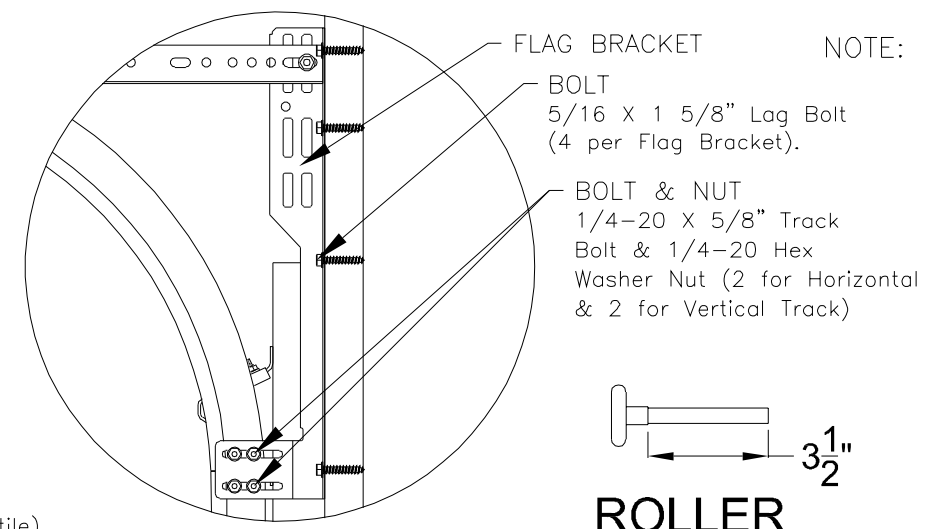

DETAIL H

ROLLER

2" Diameter Nominal Eleven Ball Nylon or Ten Ball Steel with a Minimum Workable Shaft Length Shown.

IMPACT RESISTANT

NOTE: Details on some views omitted for clarity.
Double end stiles and end hardware may be provided on wider or heavier doors.

John E. Scates, P.E.
2560 King Arthur Blvd. Ste 124-54
Lewisville, Texas 75056
Texas P.E. 56308/F2203

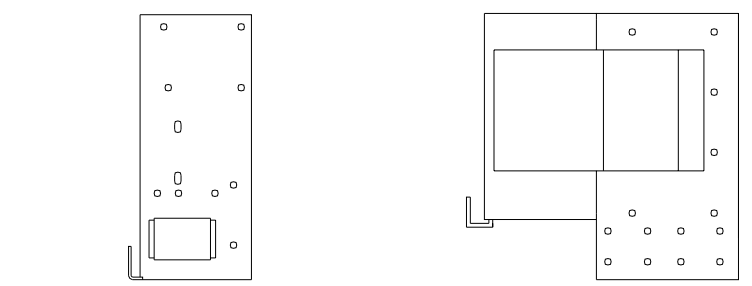

COMMERCIAL HEAVY DUTY
For Standard, High & Vertical Lift With 3" Track and Double End Stiles

COMMERCIAL HEAVY DUTY
For Low Headroom With 3" Track and Double End Stiles

ALTERNATE BOTTOM BRACKETS

NOTE: The bottom bracket tested (shown in DETAIL C) is the lightest bracket available.

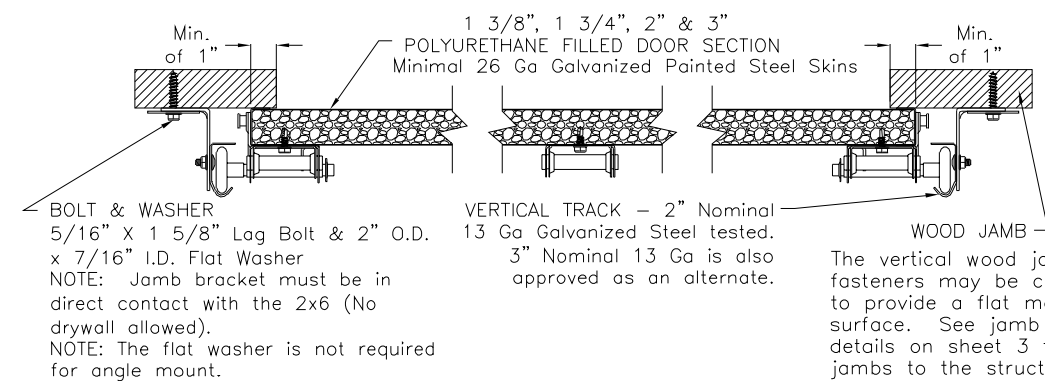

| | |
|--|-----------------------------|
| DESCRIPTION: 16 2" HT 600, 700, 2000 & 900/9000 AMERICAN TRADITION SERIES W/IMPACT RESISTANT LITES WIND LOAD SECTIONAL DOOR DESIGN PRESSURE +31.3-34.9 PSF | |
| DRAWING NO.: WLTI-0600-0194-08-31-35L | REV.: A |
| DRAWN BY: MVS | DATE DRAWN: 10/25/18 |
| MODEL(S): See Sheet 3 | REV. DATE: 2/28/22 |
| SHEET: 2 OF 4 | |

MODEL NUMBERS AND IMPACT LITE OPTIONS

| MODEL NUMBERS AVAILABLE | LITE OPTIONS AVAILABLE | | | | | AMERICAN TRADITION |
|------------------------------------|------------------------|-------------------|-------------------|--------------------------|-------------------------|--------------------|
| | CARRIAGE HOUSE | RANCH | STANDARD | LARGE COMMERCIAL 24 x 12 | SMALL COMMERCIAL 24 x 6 | |
| HT_10 & 2_10 SERIES | X | X | X | | | |
| HT_60 & 2_60 SERIES | X | | | | | |
| HT_61 & 2_61 SERIES | X | | | | | |
| HT_63 & 2_63 SERIES | X | | | | | |
| HT_64 & 2_64 SERIES | X | | | | | |
| HT_67 & 2_67 SERIES | X | | | | | |
| HT_68 & 2_68 SERIES | X | | | | | |
| HT_69 & 2_69 SERIES | X | | | | | |
| HT_70 & 2_70 SERIES | | X | | | | |
| HT_71 & 2_71 SERIES | | X | | | | |
| HT_72 & 2_72 SERIES | | X | | | | |
| HT_73 & 2_73 SERIES | | X | | | | |
| HT_74 & 2_74 SERIES | | X | | | | |
| HT_78 & 2_78 SERIES | | X | | | | |
| HT_79 & 2_79 SERIES | | X | | | | |
| HT_80 & 2_80 SERIES | | | X | | | |
| HT_81 & 2_81 SERIES | | | X | | | |
| HT_82 & 2_82 SERIES | | | X | | | |
| HT_87 & 2_87 SERIES | | | X | | | |
| HT_90 & 2_90 SERIES | | | X | | | |
| American Tradition 900/9000 SERIES | | | | | | X |
| | 38 1/2" x 12 1/2" | 38 1/2" x 10 1/2" | 17 1/2" x 10 1/2" | | | 39 3/4" x 15 1/2" |

DAY LIGHT OPENING (DLO) - WIDE x TALL

NOTE: IMPACT LITES NOT AVAILABLE IN 800 SERIES DOORS.

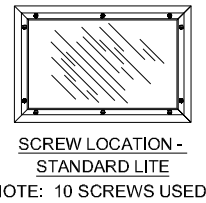
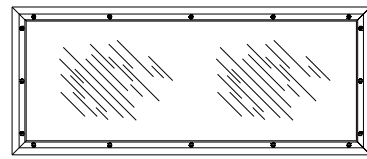
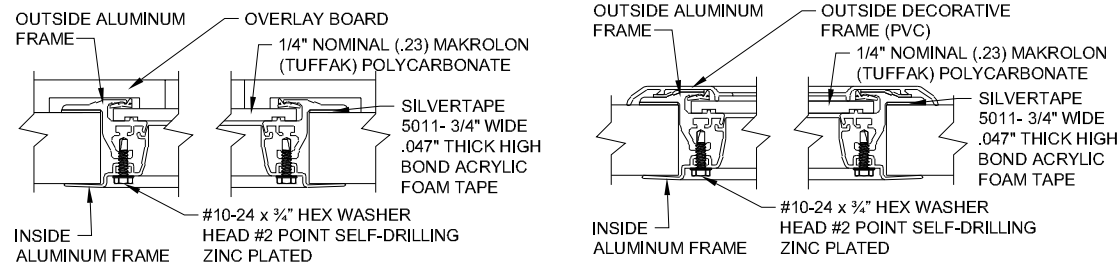

GLAZING DETAIL

NOTE: ALL GLAZING IS IMPACT RESISTANT MAKROLON (TUFFAK) GENERAL PURPOSE OR UV RESISTANT POLYCARBONATE WITH A 1/4 NOMINAL (.23) THICKNESS.

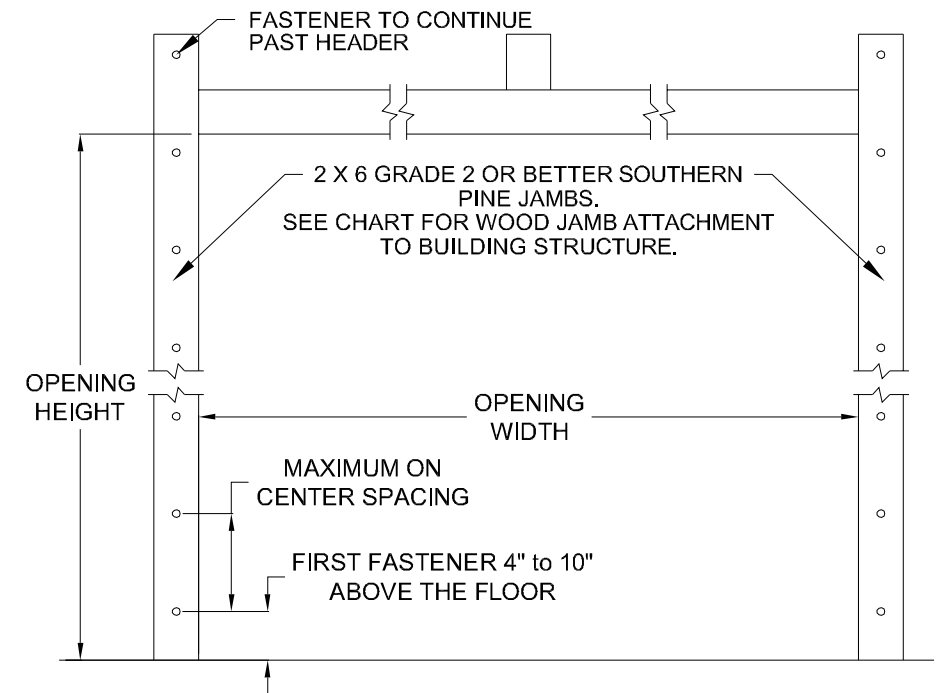

| WOOD JAMB ATTACHMENT | | | | | | |
|------------------------------------|--------------------------------------|-------------------|-----------------------|---------------------------|---------------------------|------------------------|
| Building Structure | Fastener Type | Minimum Embedment | Minimum Edge Distance | Minimum on Center Spacing | Maximum on Center Spacing | Allowable Tension Load |
| Min. 2500 PSI to 4000 PSI Concrete | Tapcon + (PLUS) 1/4" w/ 1" OD washer | 2" | 2.50" | 5.00" | 24" | 551 |
| Southern Pine | 3/8" Lag w/ 1 1/8" OD washer | 1.50" | 1.50" | 1.50" | 24" | 620 |
| Spruce Pine Fir | 3/8" Lag w/ 1 1/8" OD washer | 1.50" | 1.50" | 1.50" | 22" | 482 |

NOTE: 2X6 mounted to the wall must be Southern Pine Grade 2 or better.

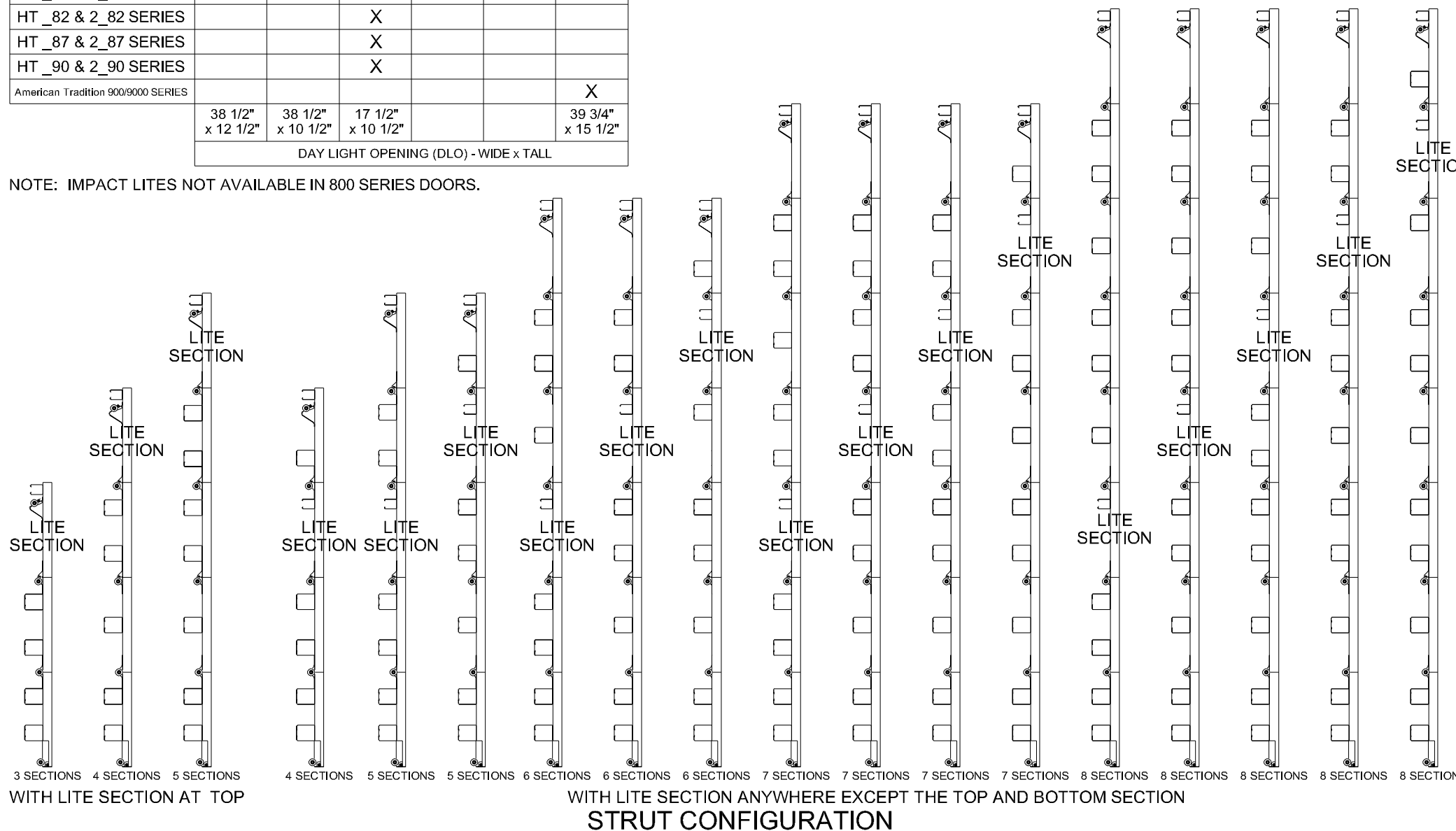

IMPACT RESISTANT

John E. Scates, P.E.
2560 King Arthur Blvd. Ste 124-54
Lewisville, Texas 75056
Texas P.E. 56308/F2203

Professional Engineer seal provided only for verification of wind load construction details.



| | | | |
|--|-----------------------------|---------------------------|--|
| DESCRIPTION: 16" HT 600, 700, 2000 & 900/9000 AMERICAN TRADITION SERIES W/IMPACT RESISTANT LITES WIND LOAD SECTIONAL DOOR DESIGN PRESSURE +31.3-34.9 PSF | | | |
| DRAWING NO.: WLTI-0600-0194-08-31-35L | REV.: A | | |
| DRAWN BY: MVS | DATE DRAWN: 10/25/18 | REV. DATE: 2/28/22 | |
| MODEL(S): See Sheet 3 | SHEET: 3 OF 4 | | |

320 Sycamore
Wauseon, Ohio 43567
© Copyright 2014

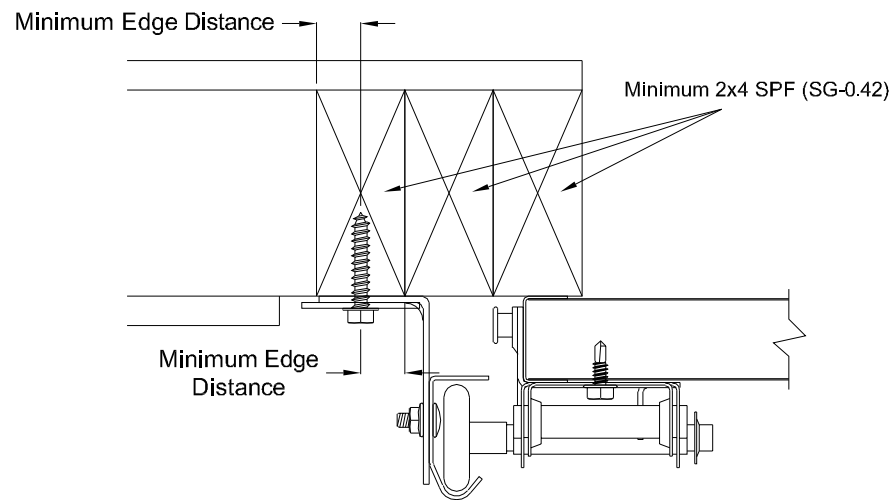

Direct Wood Mounting Detail

Bracket Mount Shown, Reverse and Continuous Angle Mount Also Approved As Alternate.

439 lbs. per anchor allowable load

5/16" Dia. Lag Screw w/1-1/8" O.D. Flat Washer (shall conform to ANSI/ASME standard B18.2.1)

Minimum Screw Length: Spruce-Pine-Fur (SPF) - 2-1/2"
Southern Pine - 1-5/8"

Minimum Edge Distance: 1/2"

Maximum on Center Spacing: 21"

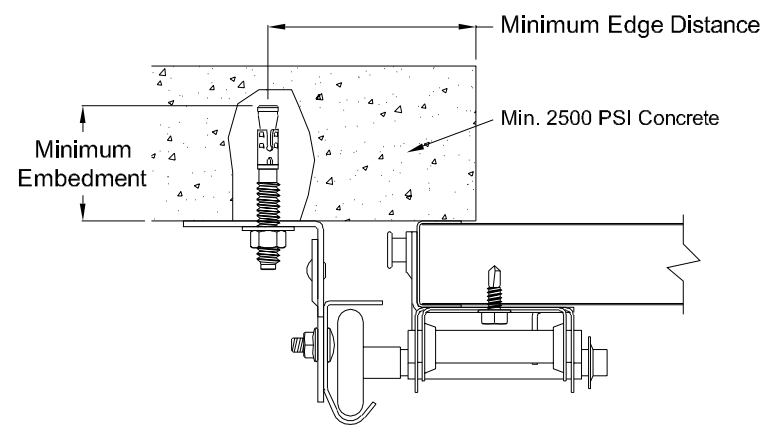

Direct Concrete Mounting Detail

Continuous Angle Clip Mount Shown, Bracket and Reverse Continuous Angle Mount Also Approved As Alternate.

831 lbs. per anchor allowable load

3/8" Dia. Ankr-Tite CCAT w/1-1/8" O.D. Flat Washer (by Wej-It Fastening Systems)

Minimum Embedment: 2-5/8"

Minimum Edge Distance: 2-1/2"

Minimum on Center Spacing: 6"

Maximum on Center Spacing: 24"

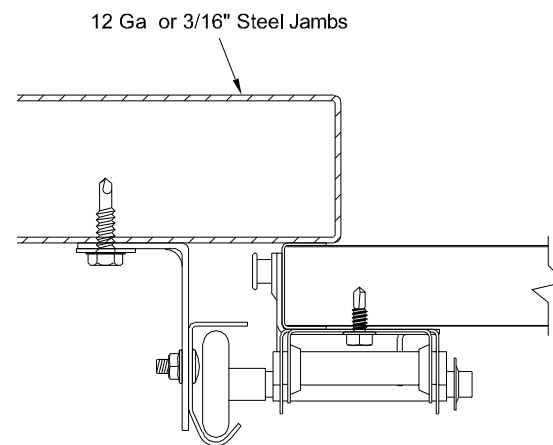

Direct Steel Mounting Detail

Bracket Mount Shown, Reverse and Continuous Angle Mount Also Approved As Alternate.

232 lbs. per anchor allowable load - 12 Ga Steel

569 lbs. per anchor allowable load - 3/16" Ga Steel
5/16"-12 Tek Self-Drilling Screw w/9/16" O.D. Flat Washer

12 Ga Maximum on Center Spacing: 11"

3/16" Maximum on Center Spacing: 24"

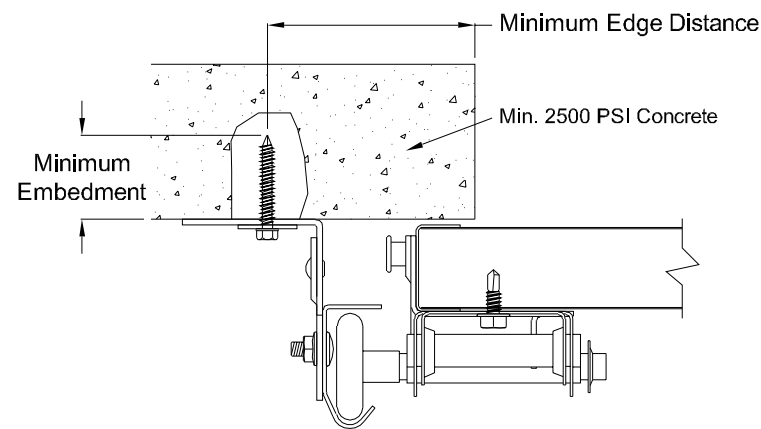

Direct Concrete Mounting Detail

Continuous Angle Clip Mount Shown, Bracket and Reverse Continuous Angle Mount Also Approved As Alternate.

562 lbs. per anchor allowable load

1/4" Dia. Concrete Self-Tapping & Wedge Anchor w/1" O.D. Flat Washer (Includes Tapcon+ (by ITW), Wedge-Bolt+ (by Powers Fasteners) & Red Head

TruBolt wedge anchor (by ITW))

Minimum Embedment: 2"

Minimum Edge Distance: 2-1/2"

Minimum on Center Spacing: 5"

Maximum on Center Spacing: 24"

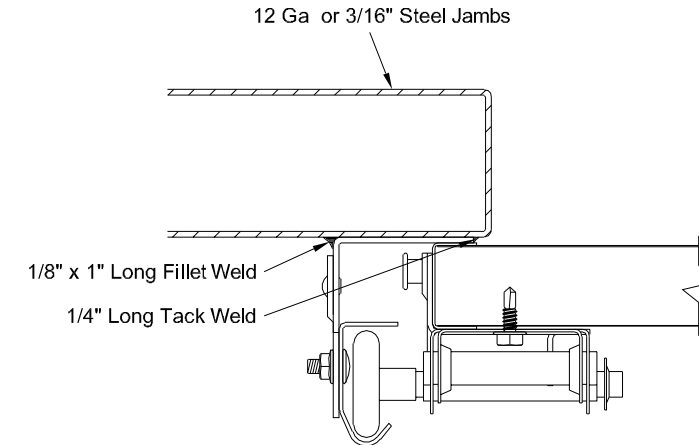

Direct Steel Mounting Detail

Reverse Continuous Angle Clip Mount Shown, Continuous Angle Mount Also Approved As Alternate.

1272 lbs. per anchor allowable load

1/8" Nom. x 1" Long Fillet and 1/4" Long Tack Weld (E60xx Electrodes Min.)

Welds performed by a certified welder or inspected by a certified welding inspector to verify integrity of the welds.

Maximum on Center Spacing: Apply welds at each roller location not to exceed 24"

IMPACT RESISTANT

John E. Scates, P.E.
2560 King Arthur Blvd. Ste 124-54
Lewisville, Texas 75056
Texas P.E. 56308/F2203

Professional Engineer seal provided only for verification of wind load construction details.



DESCRIPTION:

16' 2" HT 600, 700, 2000 & 900/9000 AMERICAN TRADITION SERIES W/IMPACT RESISTANT LITES WIND LOAD SECTIONAL DOOR DESIGN PRESSURE +31.3/-34.9 PSF

DRAWING NO.: WLTI-0600-0194-08-31-35L REV. A

DRAWN BY: MVS DATE DRAWN: 10/25/18 REV. DATE: 2/28/22

MODEL(S): See Sheet 3 SHEET: 4 OF 4

320 Sycamore
Wauseon, Ohio 43567
© Copyright 2014