

NOTE: Track configuration above the door opening does not affect the wind load rating of the door.

Door Height 8' - 0" Shown
See chart below for other door heights

Door Width 18' - 2" Shown
See chart below for other door widths

This product has been evaluated per ANSI/DASMA 108 for static air pressure.

Jamb bracket quantities shown are for use with grade 2 or better southern pine jambs.
Supporting structural elements are to be designed by a registered professional engineer for specific wind loads.

NOTICE:
These drawings are a supplement to the installation instructions for a standard door and only covers those procedures that vary from standard door installation. If these specific procedures are not followed, the door may not perform as designed.

Door Widths Up To	Design Pressures		End Stile	Model Number							
	+ psf	- psf		Minimum Center		Minimum Center		Minimum Center			
				Stiles	Hinges	Stiles	Hinges	Stiles	Hinges		
14'-2"	38.4	-42.4	Double	6	4	5	2	7	3		
16'-2"	33.7	-37.2	Double	7	3	7	3	7	3		
18'-2"	30.0	-33.1	Double	7	3	7	3	7	3		
20'-2"	24.3	-26.8	Double	9	4	9	4	11	5		
22'-2"	20.1	-22.2	Double	10	5	9	4	11	5		

Door Height	Total # of Sections	Total # of Struts	Jamb Brkts per Side
6'-0"	3	3	5
6'-0"	4	4	5
6'-3"	4	4	5
6'-6"	4	4	6
6'-9"	4	4	6
7'-0"	4	4	6
7'-3"	4	4	6
7'-6"	4	4	6
7'-6"	5	5	6
7'-9"	4	4	6
7'-9"	5	5	6
8'-0"	4	4	6
8'-0"	5	5	6

This product is designed and sold by PSF. The AHJ or Engineer of Record is responsible for determining the PSF required for any given site.

Maximum section height is 24 in.
Maximum door height is 20 ft.

All doors, even those above the tested height, are available with jamb brackets or commercial full angle. The maximum spacing of the jamb brackets/track clips should be maintained.

John E. Scates, P.E.
2560 King Arthur Blvd. Ste 124-54
Lewisville, Texas 75056
Texas P.E. 56308/F2203

COMPLIES WITH IBC/IRC 2018 Professional Engineer seal provided only for verification of wind load construction details.

 320 Sycamore Wauseon, Ohio 43567 © Copyright 2014	DESCRIPTION: 18' 2" PAN 2000 SERIES W/LITES WIND LOAD SECTIONAL DOOR DESIGN PRESSURE +30.0/-33.1 PSF	
	DRAWING NO.: WLT-2000-0218-08-30-33	REV.: A
	DRAWN BY: MVS	DATE DRAWN: 11/8/18
	MODEL(S): See Sheet 3	REV. DATE: 3/8/22
		SHEET: 1 OF 4

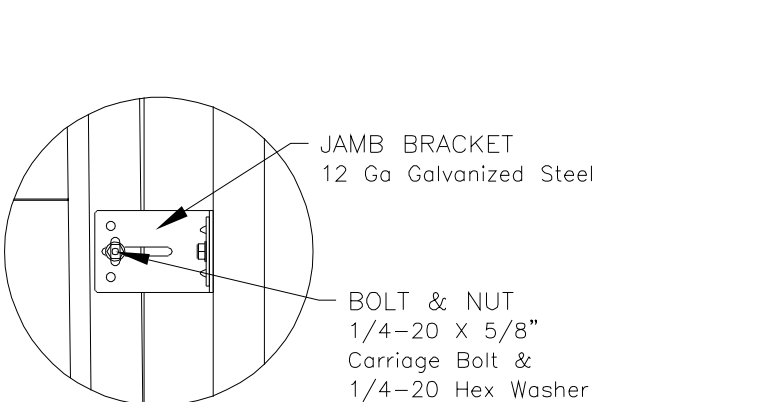
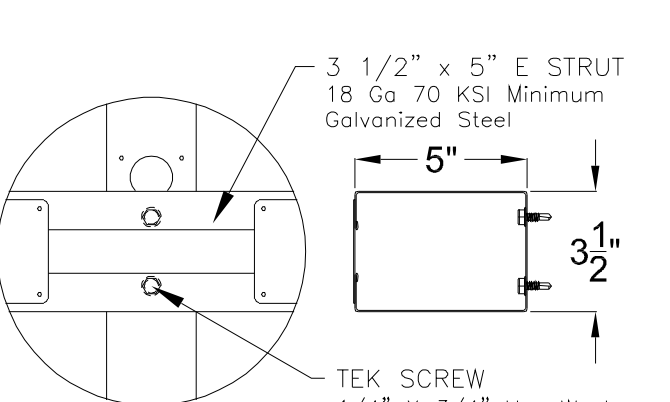
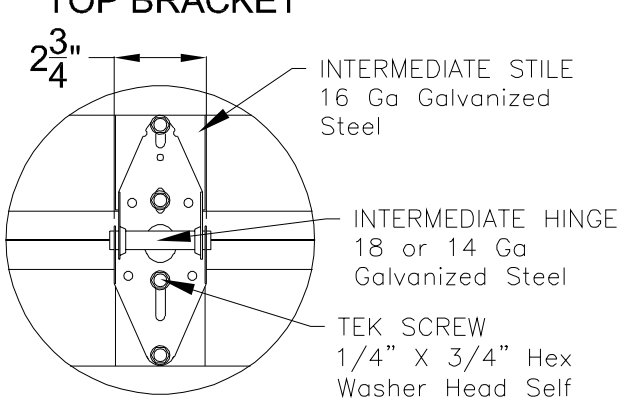
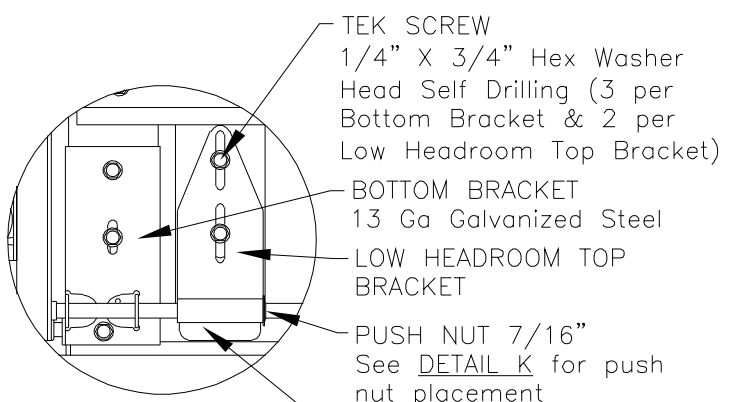
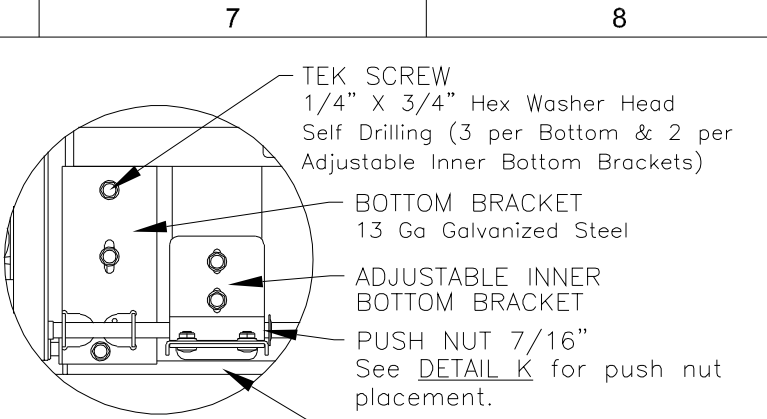
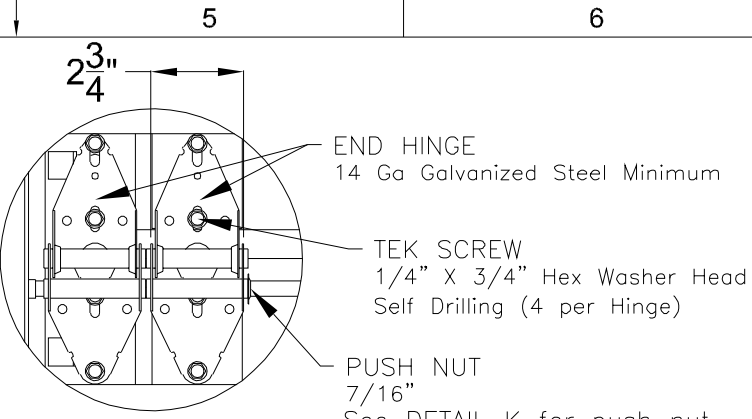
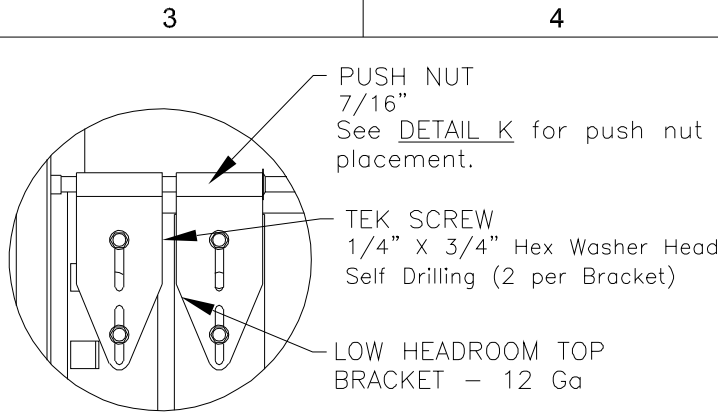
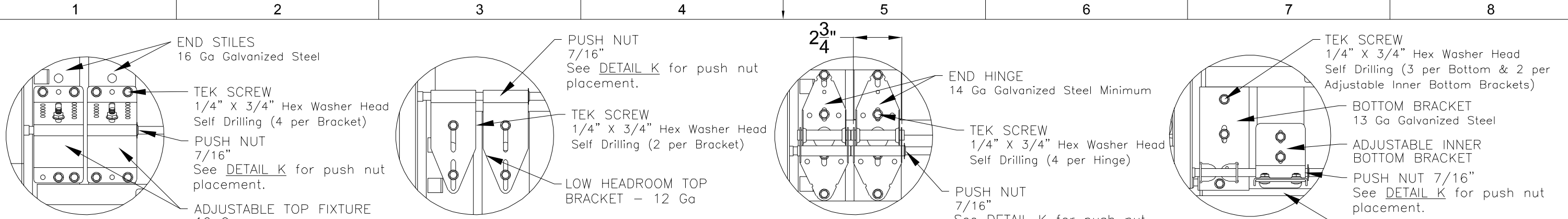

NOTE: Details on some views omitted for clarity.

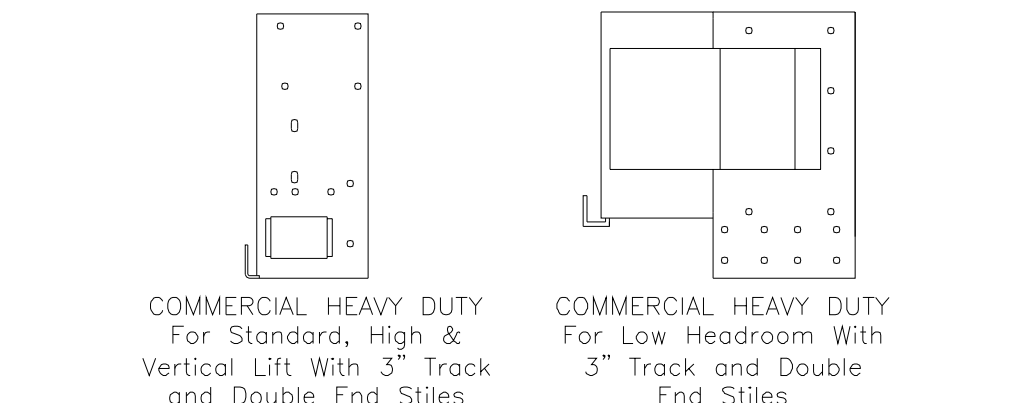

NOTE: The bottom bracket configuration tested (shown in DETAIL C) is the lightest available.

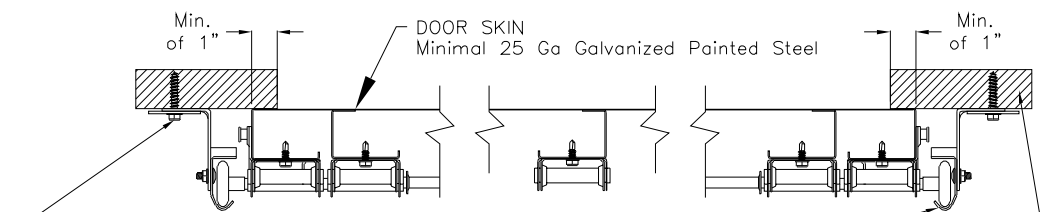
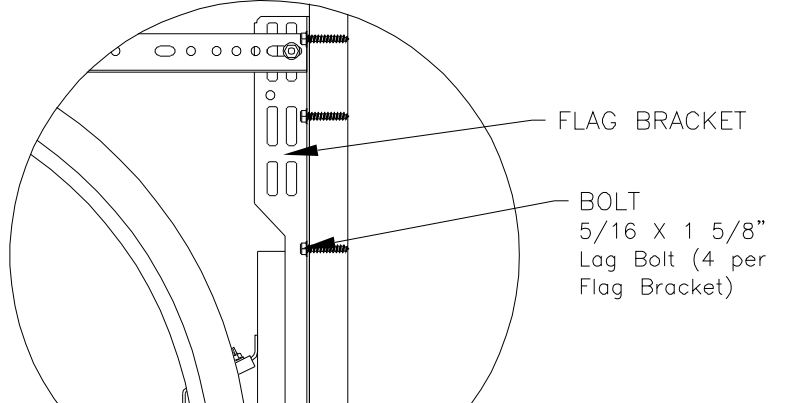
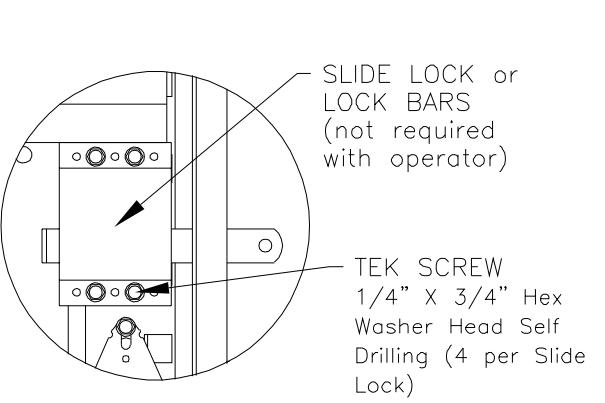

BOLT & WASHER
5/16" X 1 5/8" Lag Bolt & 2" O.D. x 7/16" I.D. Flat Washer
NOTE: Jamb bracket must be in direct contact with the 2x6 (No drywall allowed).
NOTE: The flat washer is not required for angle mount.

The vertical wood jamb fasteners may be counter sunk to provide a flat mounting surface. See jamb attachment details on sheet 3 for attaching jambs to the structure.

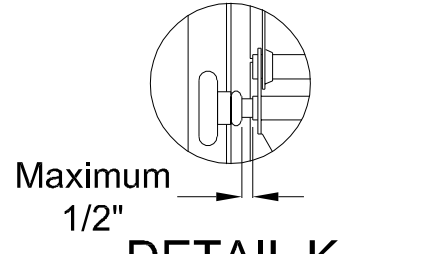

There should be a space of maximum 1/2" between the roller hub and the outside edge of the roller holder which is set by the push nut.

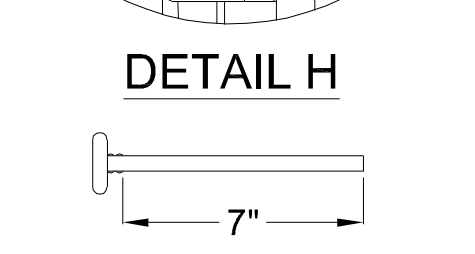

John E. Scates, P.E.
2560 King Arthur Blvd. Ste 124-54
Lewisville, Texas 75056
Texas P.E. 56308/F2203

Professional Engineer seal provided only for verification of wind load construction details.

<p>320 Sycamore Wauseon, Ohio 43567 © Copyright 2014</p>	DESCRIPTION:	
	18' 2" PAN 2000 SERIES W/LITES WIND LOAD SECTIONAL DOOR DESIGN PRESSURE +30.0/-33.1 PSF	
	DRAWING NO.: WLT-2000-0218-08-30-33	REV.: A
	DRAWN BY: MVS	DATE DRAWN: 11/8/18
MODEL(S): See Sheet 3	REV. DATE: 3/8/22	SHEET: 2 OF 4

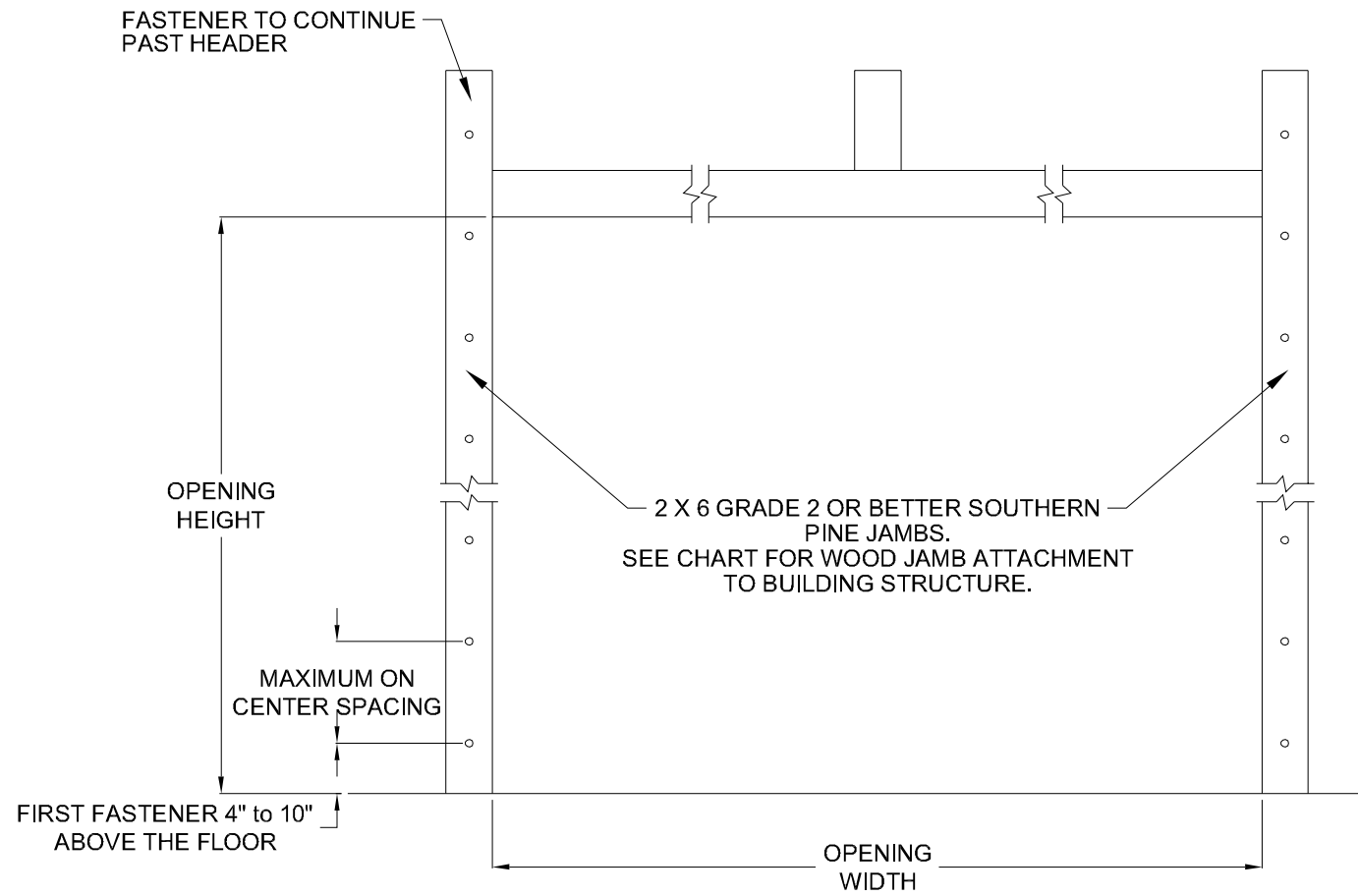

WOOD JAMB ATTACHMENT						
Building Structure	Fastener Type	Minimum Embedment	Minimum Edge Distance	Minimum on Center Spacing	Maximum on Center Spacing	Allowable Tension Load
Min. 2500 PSI to 4000 PSI Concrete	Tapcon + (PLUS) 1/4" w/ 1" OD washer	2"	2.50"	5.00"	24"	551
Southern Pine	3/8" Lag w/ 1 1/8" OD washer	1.50"	1.50"	1.50"	24"	620
Spruce Pine Fir	3/8" Lag w/ 1 1/8" OD washer	1.50"	1.50"	1.50"	21"	482

NOTE: 2X6 mounted to the wall must be Southern Pine Grade 2 or better.

MODEL NUMBERS

MODEL NUMBERS AVAILABLE
PAN C2011 SERIES
PAN C2015 SERIES
PAN C2411 SERIES
PAN C2415 SERIES
PAN C2511 SERIES
PAN C2410 & R2410 SERIES
PAN C2460 & R2460 SERIES
PAN C2461 & R2461 SERIES
PAN C2471 & R2471 SERIES
PAN C2472 & R2472 SERIES
PAN C2480 & R2480 SERIES
PAN C2481 & R2481 SERIES
PAN C2482 & R2482 SERIES
PAN R2560 SERIES
PAN R2561 SERIES
PAN R2571 SERIES
PAN R2572 SERIES
PAN R2580 SERIES
PAN R2581 SERIES
PAN R2582 SERIES

John E. Scates, P.E.
 2560 King Arthur Blvd. Ste 124-54
 Lewisville, Texas 75056
 Texas P.E. 56308/F2203

Professional Engineer seal provided only for verification of wind load construction details.



DESCRIPTION:
 18' 2" PAN 2000 SERIES W/LITES WIND LOAD SECTIONAL DOOR
 DESIGN PRESSURE +30.0/-33.1 PSF

DRAWING NO.: WLT-2000-0218-08-30-33 **REV.** A

DRAWN BY: MVS **DATE DRAWN:** 11/8/18 **REV. DATE:** 3/8/22

MODEL(S): See Sheet 3 **SHEET: 3 OF 4**

320 Sycamore
 Wauseon, Ohio 43567
 © Copyright 2014

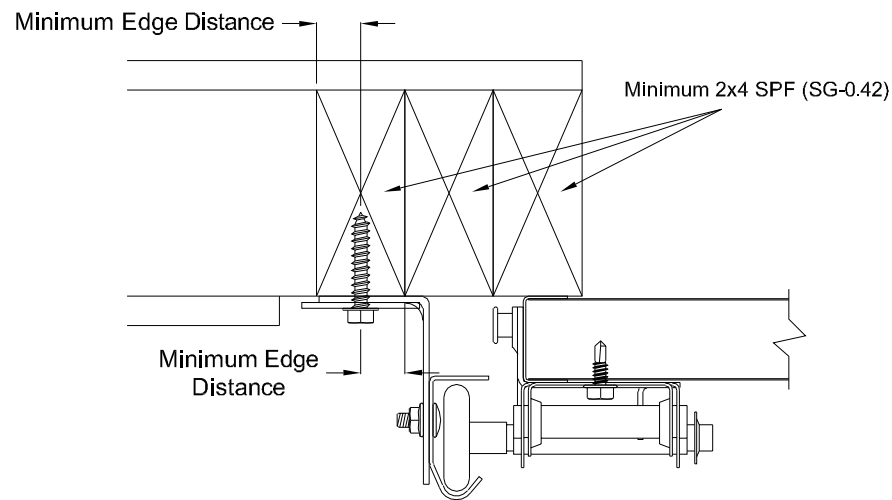

Direct Wood Mounting Detail

Bracket Mount Shown, Reverse and Continuous Angle Mount Also Approved As Alternate.

439 lbs. per anchor allowable load

5/16" Dia. Lag Screw w/1-1/8" O.D. Flat Washer (shall conform to ANSI/ASME standard B18.2.1)

Minimum Screw Length: Spruce-Pine-Fur (SPF) - 2-1/2"
Southern Pine - 1-5/8"

Minimum Edge Distance: 1/2"

Maximum on Center Spacing: 19"

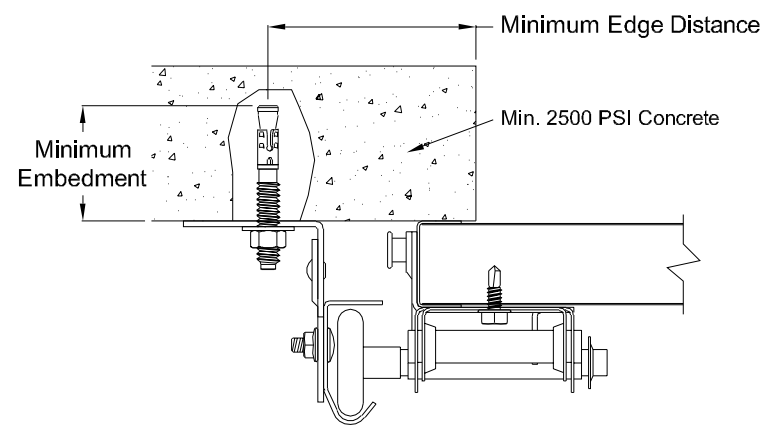

Direct Concrete Mounting Detail

Continuous Angle Clip Mount Shown, Bracket and Reverse Continuous Angle Mount Also Approved As Alternate.

831 lbs. per anchor allowable load

3/8" Dia. Ankr-Tite CCAT w/1-1/8" O.D. Flat Washer (by Wej-It Fastening Systems)

Minimum Embedment: 2-5/8"

Minimum Edge Distance: 2-1/2"

Minimum on Center Spacing: 6"

Maximum on Center Spacing: 24"

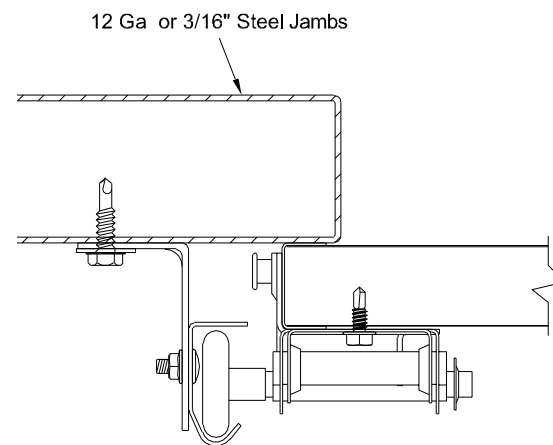

Direct Steel Mounting Detail

Bracket Mount Shown, Reverse and Continuous Angle Mount Also Approved As Alternate.

232 lbs. per anchor allowable load - 12 Ga Steel

569 lbs. per anchor allowable load - 3/16" Ga Steel
5/16"-12 Tek Self-Drilling Screw w/9/16" O.D. Flat Washer

12 Ga Maximum on Center Spacing: 10"

3/16" Maximum on Center Spacing: 24"

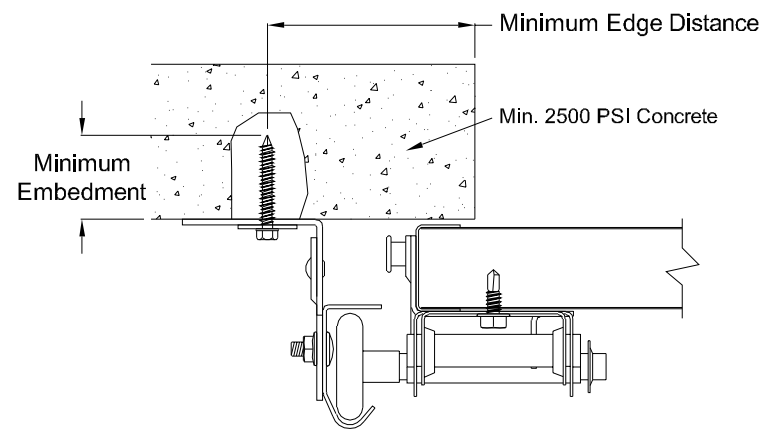

Direct Concrete Mounting Detail

Continuous Angle Clip Mount Shown, Bracket and Reverse Continuous Angle Mount Also Approved As Alternate.

562 lbs. per anchor allowable load

1/4" Dia. Concrete Self-Tapping & Wedge Anchor w/1" O.D. Flat Washer (Includes Tapcon+ (by ITW),

Wedge-Bolt+ (by Powers Fasteners) & Red Head

TruBolt wedge anchor (by ITW))

Minimum Embedment: 2"

Minimum Edge Distance: 2-1/2"

Minimum on Center Spacing: 5"

Maximum on Center Spacing: 24"

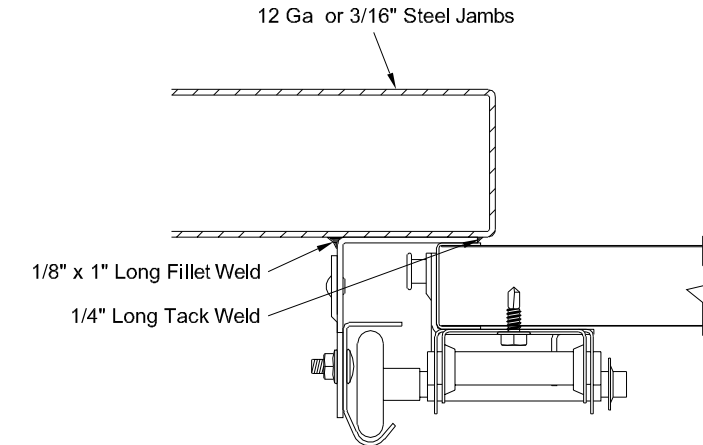

Direct Steel Mounting Detail

Reverse Continuous Angle Clip Mount Shown, Continuous Angle Mount Also Approved As Alternate.

1272 lbs. per anchor allowable load

1/8" Nom. x 1" Long Fillet and 1/4" Long Tack Weld (E60xx Electrodes Min.)

Welds performed by a certified welder or inspected by a certified welding inspector to verify integrity of the welds.

Maximum on Center Spacing: Apply welds at each roller location not to exceed 24"

John E. Scates, P.E.
2560 King Arthur Blvd. Ste 124-54
Lewisville, Texas 75056
Texas P.E. 56308/F2203

Professional Engineer seal provided only for verification of wind load construction details.



DESCRIPTION:
18' 2" PAN 2000 SERIES W/LITES WIND
LOAD SECTIONAL DOOR
DESIGN PRESSURE +30.0/-33.1 PSF

DRAWING NO.: WLT-2000-0218-08-30-33 **REV.:** A

DRAWN BY: MVS **DATE DRAWN:** 11/8/18 **REV. DATE:** 3/8/22

MODEL(S): See Sheet 3 **SHEET: 4 OF 4**

320 Sycamore
Wauseon, Ohio 43567
© Copyright 2014