

Door Width 16' - 2" Shown
See chart below for other door widths

NOTE: Track configuration above the door opening does not affect the wind load rating of the door.

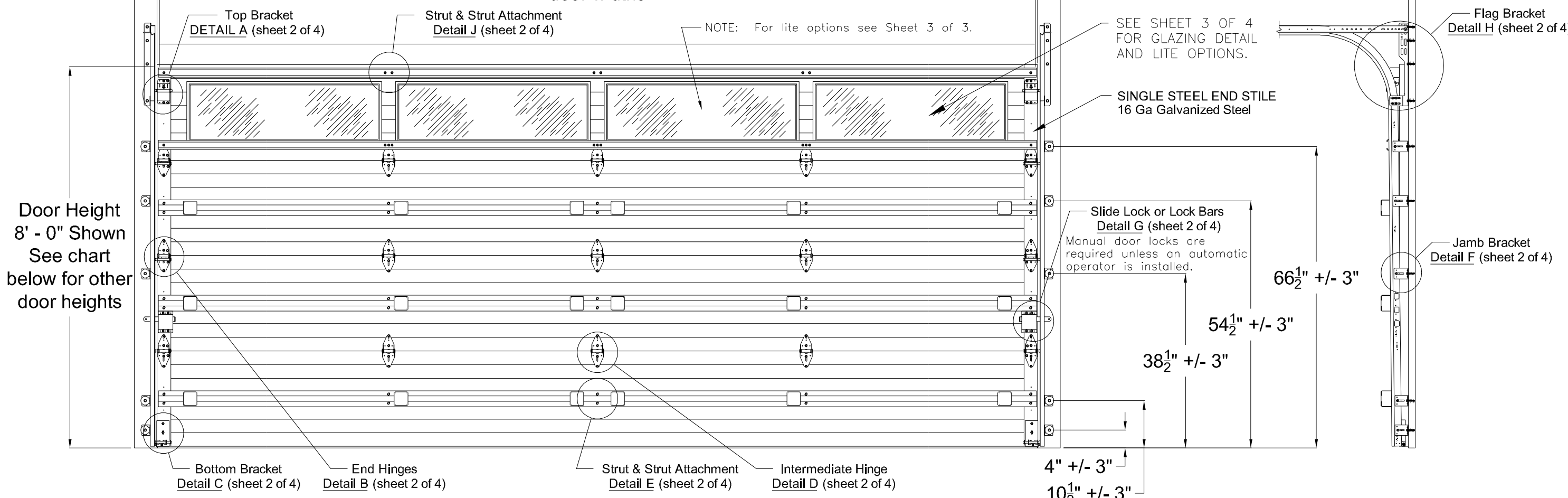

Door Height 8' - 0" Shown
See chart below for other door heights

This product has been evaluated per ANSI/DASMA 108 for static air pressure.

Model Number	
HT_60 & 2_60 SERIES	
HT_61 & 2_61 SERIES	
HT_63 & 2_63 SERIES	
HT_64 & 2_64 SERIES	
HT_68 & 2_68 SERIES	
HT_69 & 2_69 SERIES	
HT_78 & 2_78 SERIES	
HT_79 & 2_79 SERIES	
HT_80 & 2_80 SERIES	
HT_81 & 2_81 SERIES	
HT_82 & 2_82 SERIES	
HT_90 & 2_90 SERIES	
HT_67 & 2_67 SERIES	
HT_70 & 2_70 SERIES	
HT_71 & 2_71 SERIES	
HT_72 & 2_72 SERIES	
HT_73 & 2_73 SERIES	
HT_74 & 2_74 SERIES	
HT_87 & 2_87 SERIES	
American Tradition 900/9000 SERIES	
HT_10 & 2_10 SERIES	
HT_12 & 2_12 SERIES	
HT_14 & 2_14 SERIES	
HT_16 & 2_16 SERIES	
HT_32 & 2_32 SERIES	
HT_33 & 2_33 SERIES	

Door Widths Up To	Design Pressures		End Backers	Minimum Center Stiles		Minimum Center Hinges		Minimum Center Stiles		Minimum Center Hinges	
	+ psf	- psf		Stiles	Hinges	Stiles	Hinges	Stiles	Hinges		
12'-2"	31.7	-35.4	Single	2	2	2	2	2	2	2	2
14'-2"	27.2	-30.4	Single	4	4	3	3	3	3	3	3
16'-2"	23.9	-26.7	Single	3	3	3	3	3	3	3	3
18'-2"	18.9	-21.1	Single	3	3	3	3	3	3	3	3

This product is designed and sold by PSF. The AHJ or Engineer of Record is responsible for determining the PSF required for any given site.

Jamb bracket quantities shown are for use with grade 2 or better southern pine jambs. Supporting structural elements are to be designed by a registered professional engineer for specific wind loads.

Door Height	Total No. of Sections	Total # of Struts (When lite section is the top section. If not see the notice at the right)	Jamb Brkts/Side
6'-0"	3	4	4
6'-0"	4	5	4
6'-3"	4	5	4
6'-6"	4	5	5
6'-9"	4	5	5
7'-0"	4	5	5
7'-3"	4	5	5
7'-6"	4	5	5
7'-6"	5	6	5
7'-9"	4	5	5
7'-9"	5	6	5
8'-0"	4	5	5
8'-0"	5	6	5

Maximum section height is 24 in.
Maximum door height is 20 ft.

All doors, even those above the tested height, are available with jamb brackets or commercial full angle. The maximum spacing of the jamb brackets/track clips should be maintained.

NOTICE: These drawings are a supplement to the installation instructions for a standard door and only covers those procedures that vary from standard door installation. If these specific procedures are not followed, the door may not perform as designed.

NOTICE: The lite section of this door may be replaced with a section with another lite style or a solid section. In either case the strut and stile configuration should remain the same.

NOTICE: Only one lite section per door is permitted. The lite section can be used anywhere except for the bottom section. If the lite section is not the top section then the struts must be located as shown in the STRUT CONFIGURATION on sheet 3 of 4.

John E. Scates, P.E.
2560 King Arthur Blvd. Ste 124-54
Lewisville, Texas 75056
Texas P.E. 56308/F2203

COMPLIES WITH IBC/IRC 2018 Professional Engineer seal provided only for verification of wind load construction details.



DESCRIPTION:
16' 2" HT 600, 700, 2000, 800 & 900/9000 AMERICAN TRADITION SERIES W/LITES WIND LOAD SECTIONAL DOOR DESIGN PRESSURE +23.9/-26.7 PSF

DRAWING NO.: WLT-0600-0194-08-24-27L **REV.:** A
DRAWN BY: MVS **DATE DRAWN:** 10/24/18 **REV. DATE:** 3/3/22
MODEL(S): See Sheet 3 **SHEET: 1 OF 4**

320 Sycamore
Wauseon, Ohio 43567
© Copyright 2014

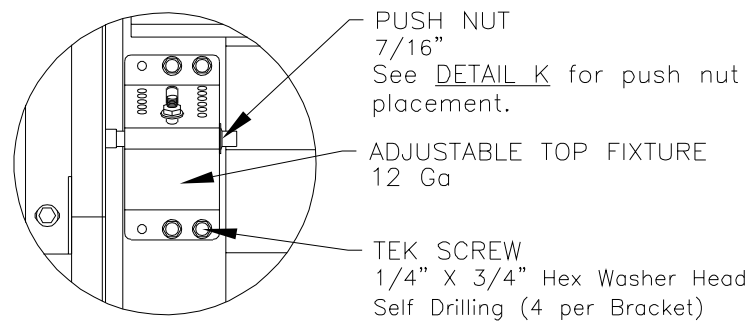

DETAIL A

PUSH NUT
7/16"
See DETAIL K for push nut placement.

ADJUSTABLE TOP FIXTURE
12 Ga

TEK SCREW
1/4" X 3/4" Hex Washer Head Self Drilling (4 per Bracket)

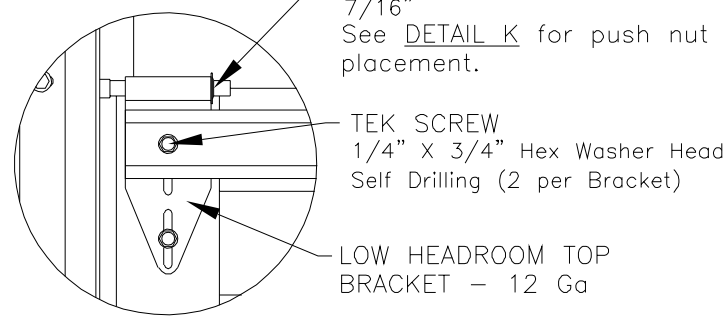

LOW HEADROOM TOP BRACKET

PUSH NUT
7/16"
See DETAIL K for push nut placement.

TEK SCREW
1/4" X 3/4" Hex Washer Head Self Drilling (2 per Bracket)

LOW HEADROOM TOP BRACKET - 12 Ga

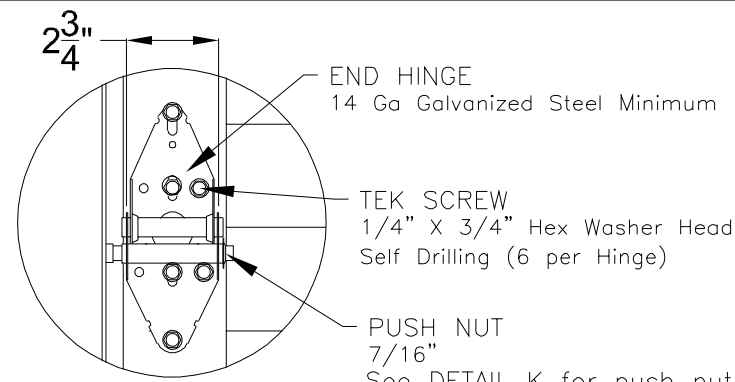

DETAIL B

END HINGE
14 Ga Galvanized Steel Minimum

TEK SCREW
1/4" X 3/4" Hex Washer Head Self Drilling (6 per Hinge)

PUSH NUT
7/16"
See DETAIL K for push nut placement.

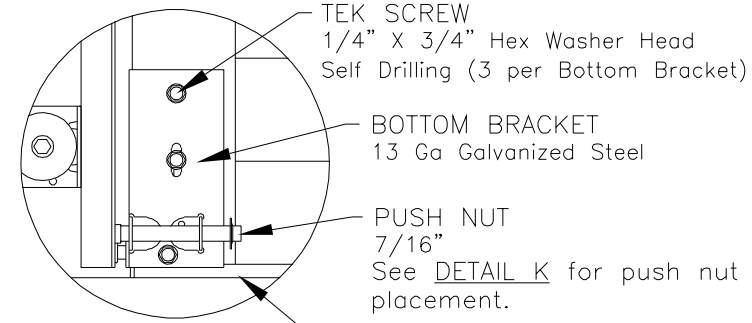

DETAIL C

TEK SCREW
1/4" X 3/4" Hex Washer Head Self Drilling (3 per Bottom Bracket)

BOTTOM BRACKET
13 Ga Galvanized Steel

PUSH NUT
7/16"
See DETAIL K for push nut placement.

BOTTOM SEAL

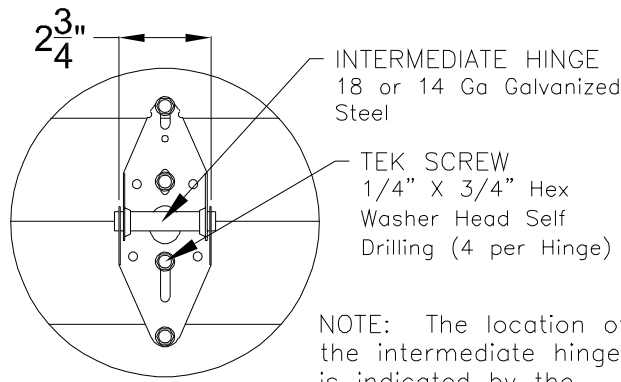

DETAIL D

INTERMEDIATE HINGE
18 or 14 Ga Galvanized Steel

TEK SCREW
1/4" X 3/4" Hex Washer Head Self Drilling (4 per Hinge)

NOTE: The location of the intermediate hinges is indicated by the toggle lock dimples at the top of each section.

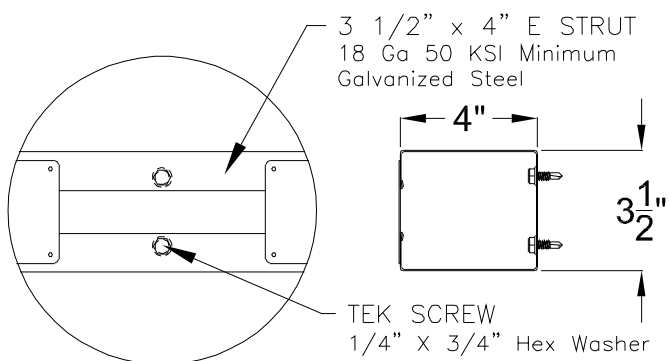

DETAIL E

3 1/2" x 4" E STRUT
18 Ga 50 KSI Minimum Galvanized Steel

TEK SCREW
1/4" X 3/4" Hex Washer Head Self Drilling (2 per End & Intermediate Stiles)

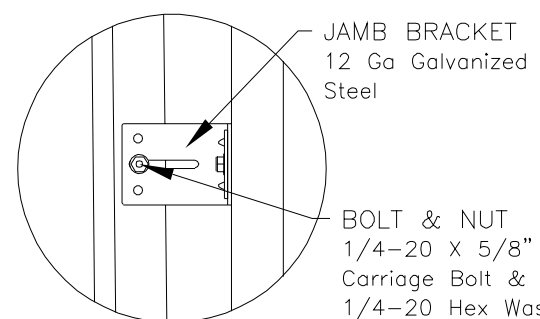

DETAIL F

JAMB BRACKET
12 Ga Galvanized Steel

BOLT & NUT
1/4-20 X 5/8" Carriage Bolt & 1/4-20 Hex Washer Nut (1 per Jamb Bracket)

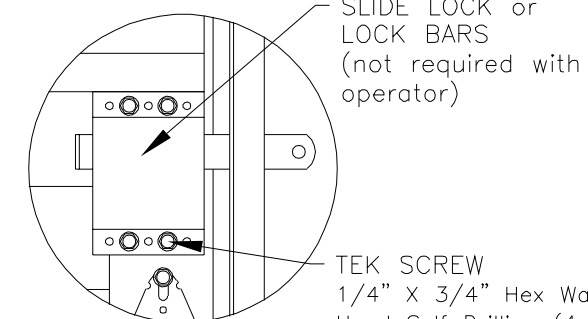

DETAIL G

SLIDE LOCK or LOCK BARS (not required with operator)

TEK SCREW
1/4" X 3/4" Hex Washer Head Self Drilling (4 per Slide Lock)

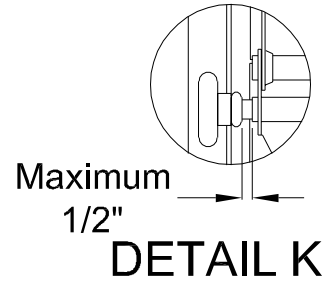

DETAIL K

There should be a space of maximum 1/2" between the roller hub and the outside edge of the roller holder which is set by the push nut.

NOTE: Details on some views omitted for clarity.
Double end stiles and end hardware may be provided on wider or heavier doors.

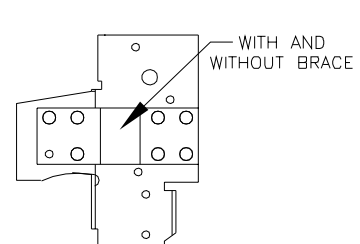

RESIDENTIAL & LIGHT COMMERCIAL
For Low Headroom With 2" Track and Single End Stiles

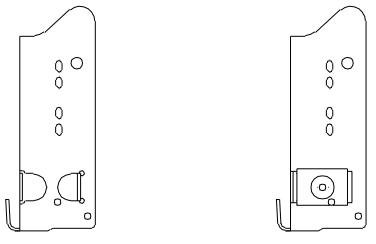

COMMERCIAL
For Standard, High & Vertical Lift With 2" Track and Single End Stiles



COMMERCIAL
For Standard, High & Vertical Lift With 3" Track and Single End Stiles

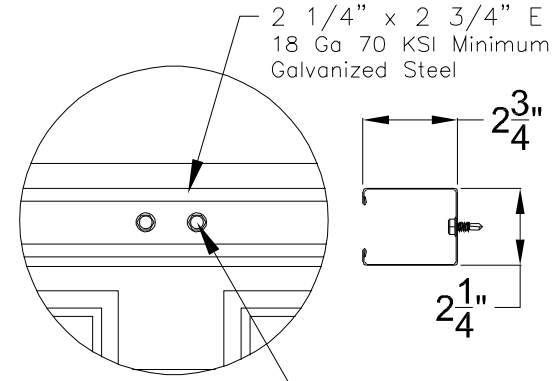

DETAIL J

2 1/4" x 2 3/4" E STRUT
18 Ga 70 KSI Minimum Galvanized Steel

TEK SCREW
1/4" x 3/4" Hex Washer Head Self Drilling (1 per End Stile & 2 per Intermediate Stile)

NOTE: 3 Screws Required at Intermediate Hinge Location

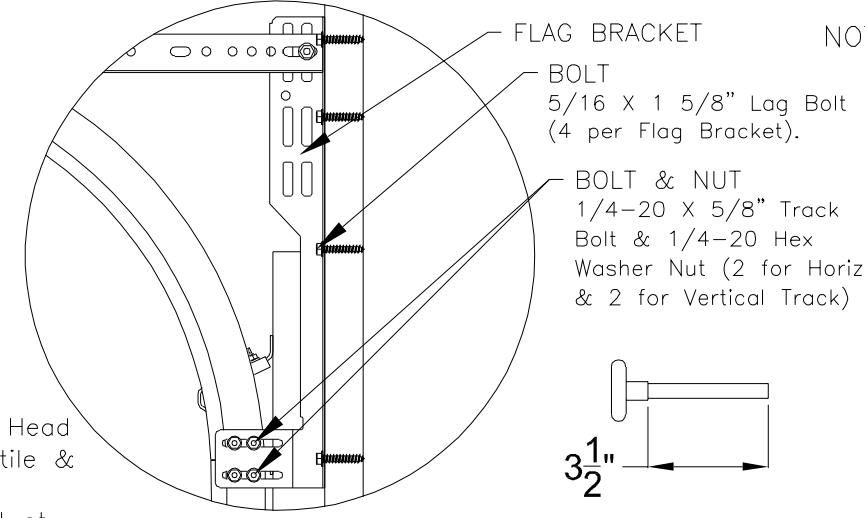

DETAIL H

FLAG BRACKET

BOLT
5/16 X 1 5/8" Lag Bolt (4 per Flag Bracket).

BOLT & NUT
1/4-20 X 5/8" Track Bolt & 1/4-20 Hex Washer Nut (2 for Horizontal & 2 for Vertical Track)

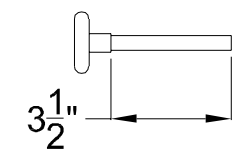

ROLLER

2" Diameter Nominal Eleven Ball Nylon or Ten Ball Steel with a Minimum Workable Shaft Length Shown.

John E. Scates, P.E.
2560 King Arthur Blvd. Ste 124-54
Lewisville, Texas 75056
Texas P.E. 56308/F2203

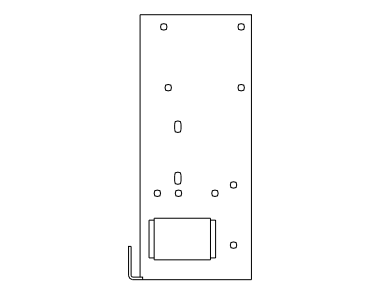

COMMERCIAL HEAVY DUTY
For Standard, High & Vertical Lift With 3" Track and Double End Stiles

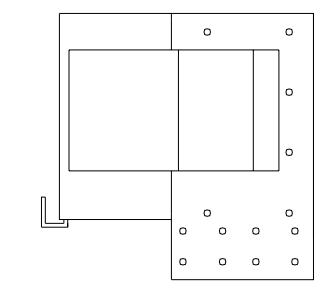

COMMERCIAL HEAVY DUTY
For Low Headroom With 3" Track and Double End Stiles

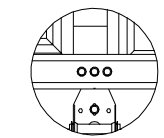

BOLT & WASHER
5/16" X 1 5/8" Log Bolt & 2" O.D. x 7/16" I.D. Flat Washer
NOTE: Jamb bracket must be in direct contact with the 2x6 (No drywall allowed).
NOTE: The flat washer is not required for angle mount.

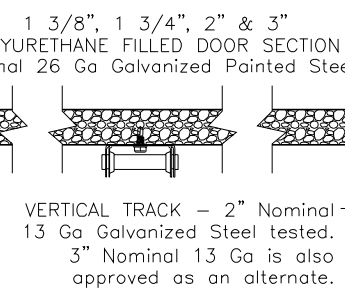

VERTICAL TRACK - 2" Nominal
13 Ga Galvanized Steel tested. 3" Nominal 13 Ga is also approved as an alternate.

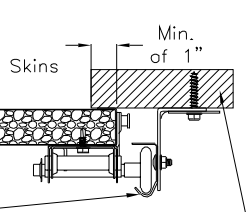

WOOD JAMB
The vertical wood jamb fasteners may be counter sunk to provide a flat mounting surface. See jamb attachment details on sheet 3 for attaching jambs to the structure.

ALTERNATE BOTTOM BRACKETS

NOTE: The bottom bracket tested (shown in DETAIL C) is the lightest bracket available.

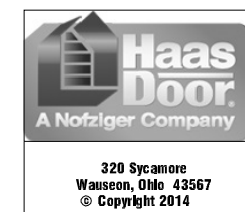

DESCRIPTION:	
16' 2" HT 600, 700, 2000, 800 & 900/9000 AMERICAN TRADITION SERIES W/LITES WIND LOAD SECTIONAL DOOR DESIGN PRESSURE +23.9/-26.7 PSF	
DRAWING NO.: WLT-0600-0194-08-24-27L	REV.: A
DRAWN BY: MVS	DATE DRAWN: 10/24/18
MODEL(S): See Sheet 3	REV. DATE: 3/3/22
SHEET: 2 OF 4	

Professional Engineer seal provided only for verification of wind load construction details.

MODEL NUMBERS AND IMPACT LITE OPTIONS

MODEL NUMBERS AVAILABLE	LITE OPTIONS AVAILABLE					AMERICAN TRADITION*
	CARRIAGE HOUSE	RANCH	STANDARD	LARGE COMMERCIAL 24 x 12	SMALL COMMERCIAL 24 x 6	
HT_14 & 2_14 SERIES				X	X	
HT_16 & 2_16 SERIES				X	X	
HT_32 & 2_32 SERIES				X	X	
HT_33 & 2_33 SERIES				X	X	
HT_10 & 2_10 SERIES	X	X	X	X	X	
HT_12 & 2_12 SERIES				X	X	
HT_60 & 2_60 SERIES	X					
HT_61 & 2_61 SERIES	X					
HT_63 & 2_63 SERIES	X					
HT_64 & 2_64 SERIES	X					
HT_67 & 2_67 SERIES	X					
HT_68 & 2_68 SERIES	X					
HT_69 & 2_69 SERIES	X					
HT_70 & 2_70 SERIES		X				
HT_71 & 2_71 SERIES		X				
HT_72 & 2_72 SERIES		X				
HT_73 & 2_73 SERIES		X				
HT_74 & 2_74 SERIES		X				
HT_78 & 2_78 SERIES		X				
HT_79 & 2_79 SERIES		X				
HT_80 & 2_80 SERIES			X			
HT_81 & 2_81 SERIES			X			
HT_82 & 2_82 SERIES			X			
HT_87 & 2_87 SERIES			X			
HT_90 & 2_90 SERIES			X			
American Tradition 900/9000 SERIES						X*
	38 1/2" x 12 1/2"	38 1/2" x 10 1/2"	17 1/2" x 10 1/2"	21 1/2" x 9 1/2"	21 1/2" x 3 1/4"	39" x 14 11/16"

DAY LIGHT OPENING (DLO) - WIDE x TALL

* The American Tradition lite option is available in tempered or insulated glass units only. See the GLAZING DETAIL for the specifications.

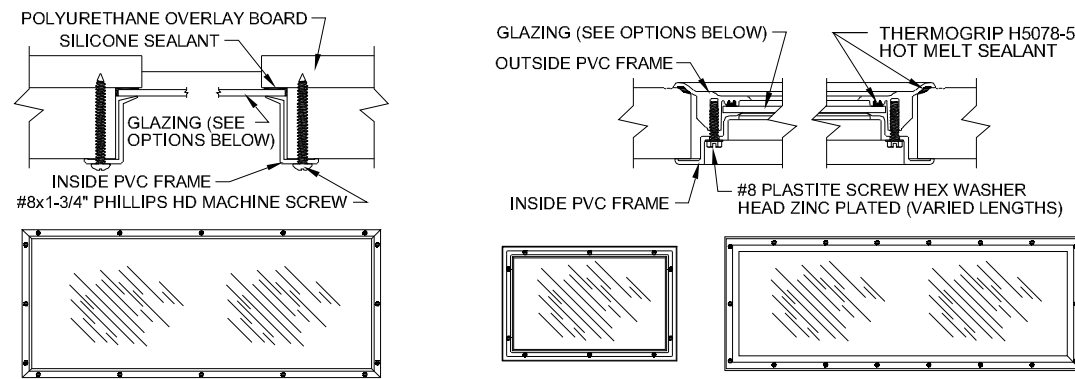

SCREW LOCATION - AM. TRADITION
NOTE: 16 SCREWS USED.

SCREW LOCATION - STANDARD LITE
NOTE: 10 SCREWS USED.

SCREW LOCATION - CARRIAGE HOUSE & RANCH LITES
NOTE: 18 SCREWS USED.

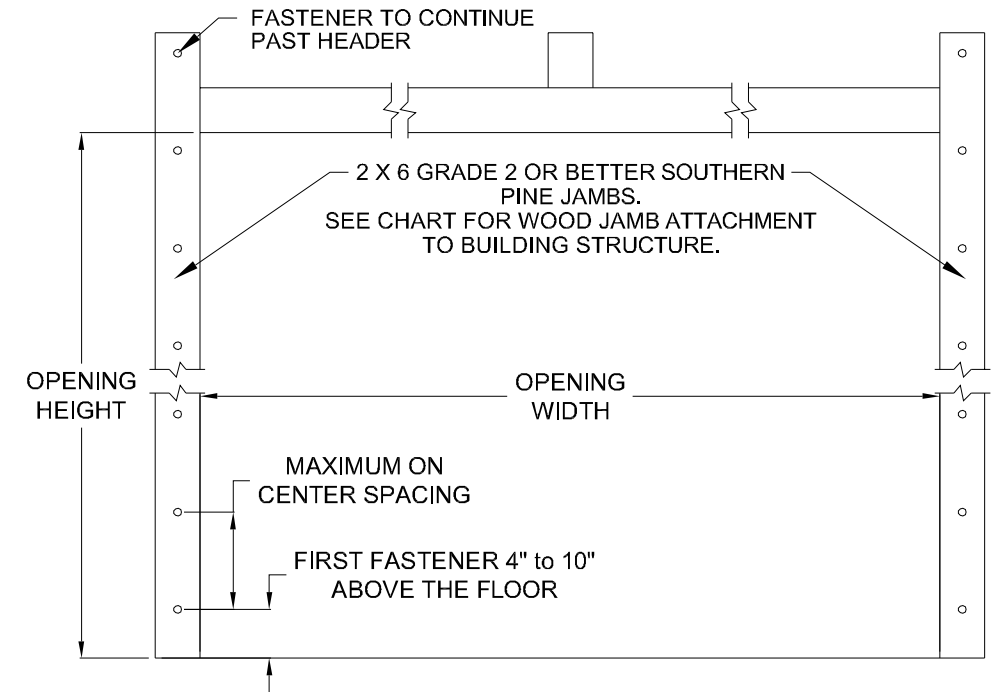
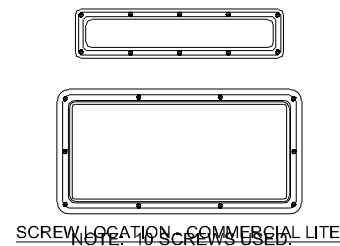

WOOD JAMB ATTACHMENT						
Building Structure	Fastener Type	Minimum Embedment	Minimum Edge Distance	Minimum on Center Spacing	Maximum on Center Spacing	Allowable Tension Load
Min. 2500 PSI to 4000 PSI Concrete	Tapcon + (PLUS) 1/4" w/ 1" OD washer	2"	2.50"	5.00"	24"	551
Southern Pine	3/8" Lag w/ 1 1/8" OD washer	1.50"	1.50"	1.50"	24"	620
Spruce Pine Fir	3/8" Lag w/ 1 1/8" OD washer	1.50"	1.50"	1.50"	24"	482

NOTE: 2X6 mounted to the wall must be Southern Pine Grade 2 or better.

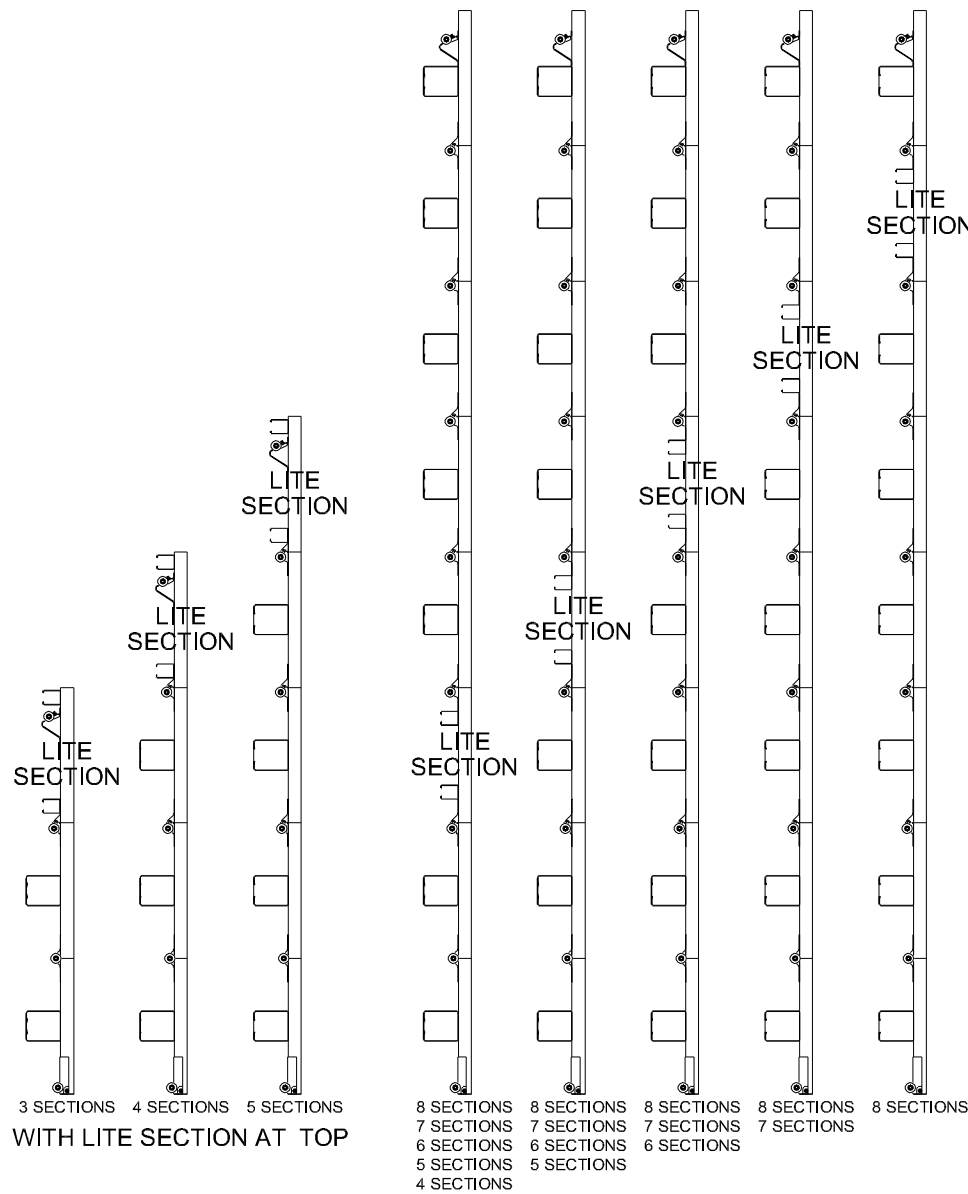

STRUT CONFIGURATION

GLAZING DETAIL

NOTE: GLAZING IS AVAILABLE IN 1/8" ANNEALED GLASS, 1/8" THICK TEMPERED GLASS, 1/2" INSULATED GLASS UNITS CONSISTING OF TWO PIECES OF 1/8" THICK TEMPERED GLASS AND A 1/4" SPACER, 1/8" ACRYLIC (SABIC INNOVATIVE PLASTICS) AND 1/8" POLYCARBONATE (LEXAN OR MAKROLON/TUFFAK). THE DAY LIGHT OPENING (DLO) OF EACH LITE OPTION IS LISTED IN THE MODEL NUMBERS AND LITE OPTIONS CHART ON SHEET 3 OF 4.

John E. Scates, P.E.
2560 King Arthur Blvd. Ste 124-54
Lewisville, Texas 75056
Texas P.E. 56308/F2203

Professional Engineer seal provided only for verification of wind load construction details.



DESCRIPTION:
16' 2" HT 600, 700, 2000, 800 & 900/9000 AMERICAN TRADITION SERIES W/LITES WIND LOAD SECTIONAL DOOR DESIGN PRESSURE +23.9/-26.7 PSF

DRAWING NO.: WLT-0600-0194-08-24-27L **REV.:** A

DRAWN BY: MVS **DATE DRAWN:** 10/24/18 **REV. DATE:** 3/3/22

MODEL(S): See Sheet 3 **SHEET: 3 OF 4**

320 Sycamore
Wauseon, Ohio 43567
© Copyright 2014

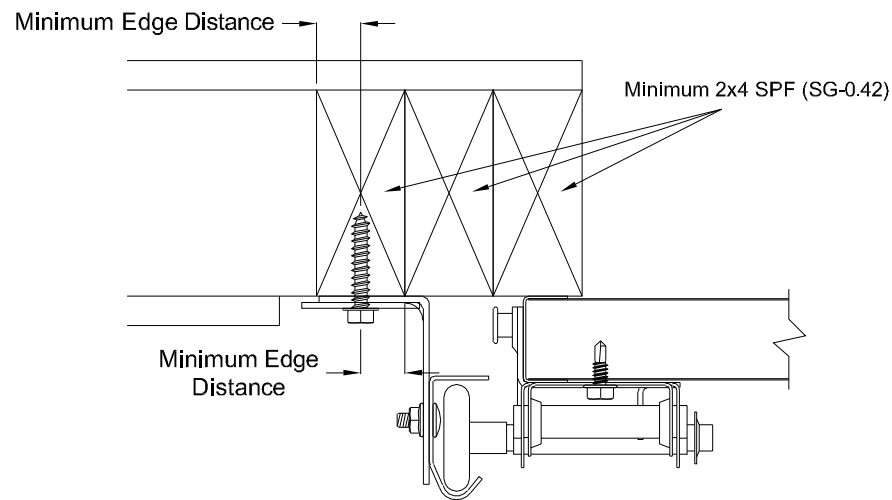

Direct Wood Mounting Detail

Bracket Mount Shown, Reverse and Continuous Angle Mount Also Approved As Alternate.

439 lbs. per anchor allowable load

5/16" Dia. Lag Screw w/1-1/8" O.D. Flat Washer (shall conform to ANSI/ASME standard B18.2.1)

Minimum Screw Length: Spruce-Pine-Fur (SPF) - 2-1/2"
Southern Pine - 1-5/8"

Minimum Edge Distance: 1/2"

Maximum on Center Spacing: 24"

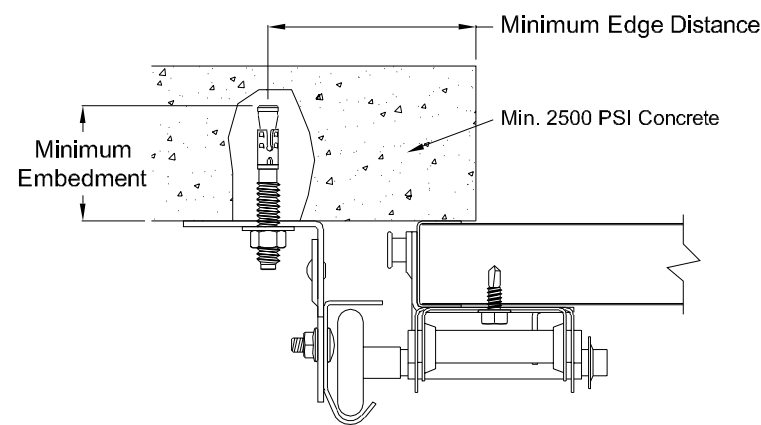

Direct Concrete Mounting Detail

Continuous Angle Clip Mount Shown, Bracket and Reverse Continuous Angle Mount Also Approved As Alternate.

831 lbs. per anchor allowable load

3/8" Dia. Ankr-Tite CCAT w/1-1/8" O.D. Flat Washer (by Wej-It Fastening Systems)

Minimum Embedment: 2-5/8"

Minimum Edge Distance: 2-1/2"

Minimum on Center Spacing: 6"

Maximum on Center Spacing: 24"

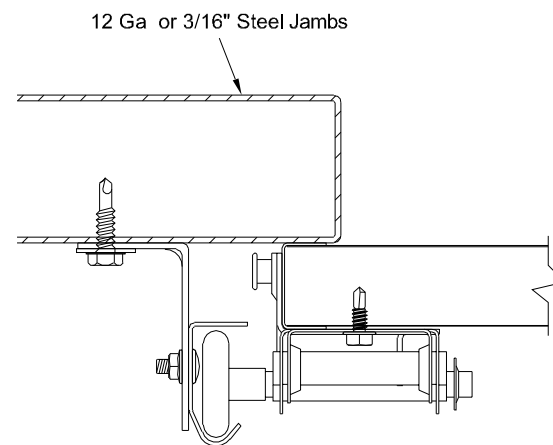

Direct Steel Mounting Detail

Bracket Mount Shown, Reverse and Continuous Angle Mount Also Approved As Alternate.

232 lbs. per anchor allowable load - 12 Ga Ste569el

lbs. per anchor allowable load - 3/16" Ga Steel

5/16"-12 Tek Self-Drilling Screw w/9/16" O.D. Flat Washer

12 Ga Maximum on Center Spacing: 14"

3/16" Maximum on Center Spacing: 24"

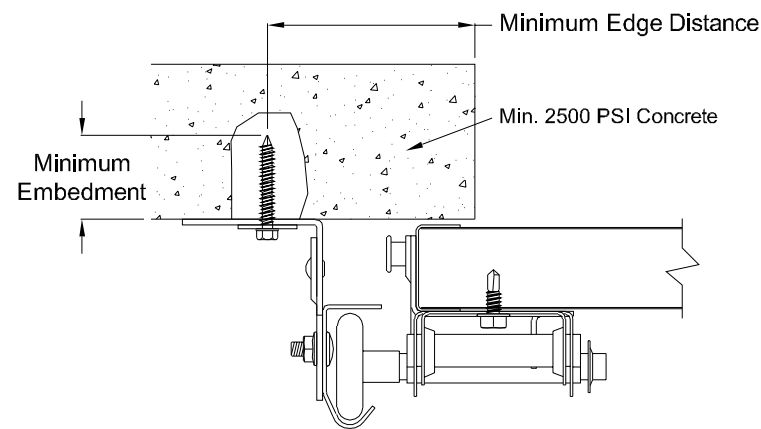

Direct Concrete Mounting Detail

Continuous Angle Clip Mount Shown, Bracket and Reverse Continuous Angle Mount Also Approved As Alternate.

562 lbs. per anchor allowable load

1/4" Dia. Concrete Self-Tapping & Wedge Anchor w/1" O.D. Flat Washer (Includes Tapcon+ (by ITW), Wedge-Bolt+ (by Powers Fasteners) & Red Head

TruBolt wedge anchor (by ITW))

Minimum Embedment: 2"

Minimum Edge Distance: 2-1/2"

Minimum on Center Spacing: 5"

Maximum on Center Spacing: 24"

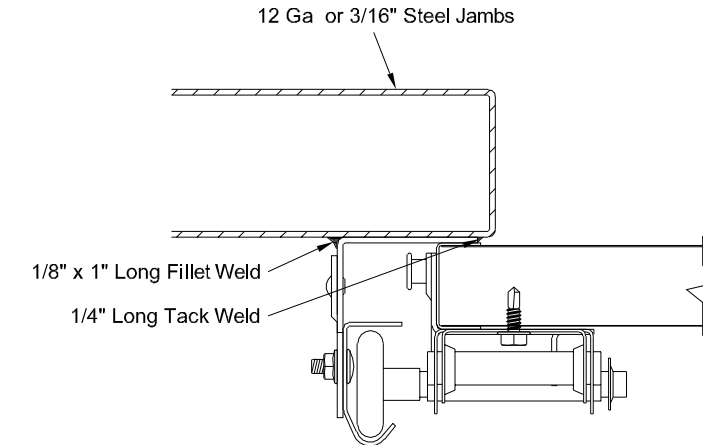

Direct Steel Mounting Detail

Reverse Continuous Angle Clip Mount Shown, Continuous Angle Mount Also Approved As Alternate.

1272 lbs. per anchor allowable load

1/8" Nom. x 1" Long Fillet and 1/4" Long Tack Weld (E60xx Electrodes Min.)

Welds performed by a certified welder or inspected by a certified welding inspector to verify integrity of the welds.

Maximum on Center Spacing: Apply welds at each roller location not to exceed 24"

John E. Scates, P.E.
2560 King Arthur Blvd. Ste 124-54
Lewisville, Texas 75056
Texas P.E. 56308/F2203

Professional Engineer seal provided only for verification of wind load construction details.



DESCRIPTION:
16' 2" HT 600, 700, 2000, 800 & 900/9000 AMERICAN TRADITION SERIES W/LITES WIND LOAD SECTIONAL DOOR DESIGN PRESSURE +23.9/-26.7 PSF

DRAWING NO.: WLT-0600-0194-08-24-27L **REV.:** A

DRAWN BY: MVS **DATE DRAWN:** 10/24/18 **REV. DATE:** 3/3/22

MODEL(S): See Sheet 3 **SHEET: 4 OF 4**

320 Sycamore
Wauseon, Ohio 43567
© Copyright 2014