

NOTE: Track configuration above the door opening does not affect the wind load rating of the door.

This product has been evaluated per ANSI/DASMA 108 for static air pressure.

Jamb bracket quantities shown are for use with grade 2 or better southern pine jambs. Supporting structural elements are to be designed by a registered professional engineer for specific wind loads.

**NOTICE:** These drawings are a supplement to the installation instructions for a standard door and only covers those procedures that vary from standard door installation. If these specific procedures are not followed, the door may not perform as designed.

**NOTICE:** The lite section of this door may be replaced with a section with another lite style or a solid section. In either case the strut and stile configuration should remain the same.

**NOTICE:** Only one lite section per door is permitted. The lite section can be used anywhere except for the bottom section. If the lite section is not the top section then the struts must be located as shown in the STRUT CONFIGURATION on sheet 3 of 4.

John E. Scates, P.E.  
2560 King Arthur Blvd. Ste 124-54  
Lewisville, Texas 75056  
Texas P.E. 56308/F2203

COMPLIES WITH IBC/IRC 2018 Professional Engineer seal provided only for verification of wind load construction details.

		Model Number					
		HT_60 & 2_60 SERIES		HT_61 & 2_61 SERIES		HT_63 & 2_63 SERIES	
		HT_64 & 2_64 SERIES		HT_67 & 2_67 SERIES		HT_68 & 2_68 SERIES	
		HT_69 & 2_69 SERIES		HT_70 & 2_70 SERIES		HT_71 & 2_71 SERIES	
		HT_72 & 2_72 SERIES		HT_73 & 2_73 SERIES		HT_74 & 2_74 SERIES	
		HT_75 & 2_75 SERIES		HT_76 & 2_76 SERIES		HT_77 & 2_77 SERIES	
		HT_78 & 2_78 SERIES		HT_79 & 2_79 SERIES		HT_80 & 2_80 SERIES	
		HT_81 & 2_81 SERIES		HT_82 & 2_82 SERIES		HT_83 & 2_83 SERIES	
		HT_84 & 2_84 SERIES		HT_85 & 2_85 SERIES		HT_86 & 2_86 SERIES	
		HT_87 & 2_87 SERIES		HT_88 & 2_88 SERIES		HT_89 & 2_89 SERIES	
		HT_90 & 2_90 SERIES		HT_91 & 2_91 SERIES		HT_92 & 2_92 SERIES	
		HT_93 & 2_93 SERIES		HT_94 & 2_94 SERIES		HT_95 & 2_95 SERIES	
		HT_96 & 2_96 SERIES		HT_97 & 2_97 SERIES		HT_98 & 2_98 SERIES	
		HT_99 & 2_99 SERIES		HT_100 & 2_100 SERIES		HT_101 & 2_101 SERIES	
		HT_102 & 2_102 SERIES		HT_103 & 2_103 SERIES		HT_104 & 2_104 SERIES	
		HT_105 & 2_105 SERIES		HT_106 & 2_106 SERIES		HT_107 & 2_107 SERIES	
		HT_108 & 2_108 SERIES		HT_109 & 2_109 SERIES		HT_110 & 2_110 SERIES	
		HT_111 & 2_111 SERIES		HT_112 & 2_112 SERIES		HT_113 & 2_113 SERIES	
		HT_114 & 2_114 SERIES		HT_115 & 2_115 SERIES		HT_116 & 2_116 SERIES	
		HT_117 & 2_117 SERIES		HT_118 & 2_118 SERIES		HT_119 & 2_119 SERIES	
		HT_120 & 2_120 SERIES		HT_121 & 2_121 SERIES		HT_122 & 2_122 SERIES	
		HT_123 & 2_123 SERIES		HT_124 & 2_124 SERIES		HT_125 & 2_125 SERIES	
		HT_126 & 2_126 SERIES		HT_127 & 2_127 SERIES		HT_128 & 2_128 SERIES	
		HT_129 & 2_129 SERIES		HT_130 & 2_130 SERIES		HT_131 & 2_131 SERIES	
		HT_132 & 2_132 SERIES		HT_133 & 2_133 SERIES		HT_134 & 2_134 SERIES	
		HT_135 & 2_135 SERIES		HT_136 & 2_136 SERIES		HT_137 & 2_137 SERIES	
		HT_138 & 2_138 SERIES		HT_139 & 2_139 SERIES		HT_140 & 2_140 SERIES	
		HT_141 & 2_141 SERIES		HT_142 & 2_142 SERIES		HT_143 & 2_143 SERIES	
		HT_144 & 2_144 SERIES		HT_145 & 2_145 SERIES		HT_146 & 2_146 SERIES	
		HT_147 & 2_147 SERIES		HT_148 & 2_148 SERIES		HT_149 & 2_149 SERIES	
		HT_150 & 2_150 SERIES		HT_151 & 2_151 SERIES		HT_152 & 2_152 SERIES	
		HT_153 & 2_153 SERIES		HT_154 & 2_154 SERIES		HT_155 & 2_155 SERIES	
		HT_156 & 2_156 SERIES		HT_157 & 2_157 SERIES		HT_158 & 2_158 SERIES	
		HT_159 & 2_159 SERIES		HT_160 & 2_160 SERIES		HT_161 & 2_161 SERIES	
		HT_162 & 2_162 SERIES		HT_163 & 2_163 SERIES		HT_164 & 2_164 SERIES	
		HT_165 & 2_165 SERIES		HT_166 & 2_166 SERIES		HT_167 & 2_167 SERIES	
		HT_168 & 2_168 SERIES		HT_169 & 2_169 SERIES		HT_170 & 2_170 SERIES	
		HT_171 & 2_171 SERIES		HT_172 & 2_172 SERIES		HT_173 & 2_173 SERIES	
		HT_174 & 2_174 SERIES		HT_175 & 2_175 SERIES		HT_176 & 2_176 SERIES	
		HT_177 & 2_177 SERIES		HT_178 & 2_178 SERIES		HT_179 & 2_179 SERIES	
		HT_180 & 2_180 SERIES		HT_181 & 2_181 SERIES		HT_182 & 2_182 SERIES	
		HT_183 & 2_183 SERIES		HT_184 & 2_184 SERIES		HT_185 & 2_185 SERIES	
		HT_186 & 2_186 SERIES		HT_187 & 2_187 SERIES		HT_188 & 2_188 SERIES	
		HT_189 & 2_189 SERIES		HT_190 & 2_190 SERIES		HT_191 & 2_191 SERIES	
		HT_192 & 2_192 SERIES		HT_193 & 2_193 SERIES		HT_194 & 2_194 SERIES	
		HT_195 & 2_195 SERIES		HT_196 & 2_196 SERIES		HT_197 & 2_197 SERIES	
		HT_198 & 2_198 SERIES		HT_199 & 2_199 SERIES		HT_200 & 2_200 SERIES	
		HT_201 & 2_201 SERIES		HT_202 & 2_202 SERIES		HT_203 & 2_203 SERIES	
		HT_204 & 2_204 SERIES		HT_205 & 2_205 SERIES		HT_206 & 2_206 SERIES	
		HT_207 & 2_207 SERIES		HT_208 & 2_208 SERIES		HT_209 & 2_209 SERIES	
		HT_210 & 2_210 SERIES		HT_211 & 2_211 SERIES		HT_212 & 2_212 SERIES	
		HT_213 & 2_213 SERIES		HT_214 & 2_214 SERIES		HT_215 & 2_215 SERIES	
		HT_216 & 2_216 SERIES		HT_217 & 2_217 SERIES		HT_218 & 2_218 SERIES	
		HT_219 & 2_219 SERIES		HT_220 & 2_220 SERIES		HT_221 & 2_221 SERIES	
		HT_222 & 2_222 SERIES		HT_223 & 2_223 SERIES		HT_224 & 2_224 SERIES	
		HT_225 & 2_225 SERIES		HT_226 & 2_226 SERIES		HT_227 & 2_227 SERIES	
		HT_228 & 2_228 SERIES		HT_229 & 2_229 SERIES		HT_230 & 2_230 SERIES	
		HT_231 & 2_231 SERIES		HT_232 & 2_232 SERIES		HT_233 & 2_233 SERIES	
		HT_234 & 2_234 SERIES		HT_235 & 2_235 SERIES		HT_236 & 2_236 SERIES	
		HT_237 & 2_237 SERIES		HT_238 & 2_238 SERIES		HT_239 & 2_239 SERIES	
		HT_240 & 2_240 SERIES		HT_241 & 2_241 SERIES		HT_242 & 2_242 SERIES	
		HT_243 & 2_243 SERIES		HT_244 & 2_244 SERIES		HT_245 & 2_245 SERIES	
		HT_246 & 2_246 SERIES		HT_247 & 2_247 SERIES		HT_248 & 2_248 SERIES	
		HT_249 & 2_249 SERIES		HT_250 & 2_250 SERIES		HT_251 & 2_251 SERIES	
		HT_252 & 2_252 SERIES		HT_253 & 2_253 SERIES		HT_254 & 2_254 SERIES	
		HT_255 & 2_255 SERIES		HT_256 & 2_256 SERIES		HT_257 & 2_257 SERIES	
		HT_258 & 2_258 SERIES		HT_259 & 2_259 SERIES		HT_260 & 2_260 SERIES	
		HT_261 & 2_261 SERIES		HT_262 & 2_262 SERIES		HT_263 & 2_263 SERIES	
		HT_264 & 2_264 SERIES		HT_265 & 2_265 SERIES		HT_266 & 2_266 SERIES	
		HT_267 & 2_267 SERIES		HT_268 & 2_268 SERIES		HT_269 & 2_269 SERIES	
		HT_270 & 2_270 SERIES		HT_271 & 2_271 SERIES		HT_272 & 2_272 SERIES	
		HT_273 & 2_273 SERIES		HT_274 & 2_274 SERIES		HT_275 & 2_275 SERIES	
		HT_276 & 2_276 SERIES		HT_277 & 2_277 SERIES		HT_278 & 2_278 SERIES	
		HT_279 & 2_279 SERIES		HT_280 & 2_280 SERIES		HT_281 & 2_281 SERIES	
		HT_282 & 2_282 SERIES		HT_283 & 2_283 SERIES		HT_284 & 2_284 SERIES	
		HT_285 & 2_285 SERIES		HT_286 & 2_286 SERIES		HT_287 & 2_287 SERIES	
		HT_288 & 2_288 SERIES		HT_289 & 2_289 SERIES		HT_290 & 2_290 SERIES	
		HT_291 & 2_291 SERIES		HT_292 & 2_292 SERIES		HT_293 & 2_293 SERIES	
		HT_294 & 2_294 SERIES		HT_295 & 2_295 SERIES		HT_296 & 2_296 SERIES	
		HT_297 & 2_297 SERIES		HT_298 & 2_298 SERIES		HT_299 & 2_299 SERIES	
		HT_300 & 2_300 SERIES		HT_301 & 2_301 SERIES		HT_302 & 2_302 SERIES	
		HT_303 & 2_303 SERIES		HT_304 & 2_304 SERIES		HT_305 & 2_305 SERIES	
		HT_306 & 2_306 SERIES		HT_307 & 2_307 SERIES		HT_308 & 2_308 SERIES	
		HT_309 & 2_309 SERIES		HT_310 & 2_310 SERIES		HT_311 & 2_311 SERIES	
		HT_312 & 2_312 SERIES		HT_313 & 2_313 SERIES		HT_314 & 2_314 SERIES	
		HT_315 & 2_315 SERIES		HT_316 & 2_316 SERIES		HT_317 & 2_317 SERIES	
		HT_318 & 2_318 SERIES		HT_319 & 2_319 SERIES		HT_320 & 2_320 SERIES	
		HT_321 & 2_321 SERIES		HT_322 & 2_322 SERIES		HT_323 & 2_323 SERIES	
		HT_324 & 2_324 SERIES		HT_325 & 2_325 SERIES		HT_326 & 2_326 SERIES	
		HT_327 & 2_327 SERIES		HT_328 & 2_328 SERIES		HT_329 & 2_329 SERIES	
		HT_330 & 2_330 SERIES		HT_331 & 2_331 SERIES		HT_332 & 2_332 SERIES	
		HT_333 & 2_333 SERIES		HT_334 & 2_334 SERIES		HT_335 & 2_335 SERIES	
		HT_336 & 2_336 SERIES		HT_337 & 2_337 SERIES		HT_338 & 2_338 SERIES	
		HT_339 & 2_339 SERIES		HT_340 & 2_340 SERIES		HT_341 & 2_341 SERIES	
		HT_342 & 2_342 SERIES		HT_343 & 2_343 SERIES		HT_344 & 2_344 SERIES	
		HT_345 & 2_345 SERIES		HT_346 & 2_346 SERIES		HT_347 & 2_347 SERIES	
		HT_348 & 2_348 SERIES		HT_349 & 2_349 SERIES		HT_350 & 2_350 SERIES	
		HT_351 & 2_351 SERIES		HT_352 & 2_352 SERIES		HT_353 & 2_353 SERIES	
		HT_354 & 2_354 SERIES		HT_355 & 2_355 SERIES		HT_356 & 2_356 SERIES	
		HT_357 & 2_357 SERIES		HT_358 & 2_358 SERIES		HT_359 & 2_359 SERIES	
		HT_360 & 2_360 SERIES		HT_361 & 2_361 SERIES		HT_362 & 2_362 SERIES	
		HT_363 & 2_363 SERIES		HT_364 & 2_364 SERIES		HT_365 & 2_365 SERIES	
		HT_366 & 2_366 SERIES		HT_367 & 2_367 SERIES		HT_368 & 2_368 SERIES	
		HT_369 & 2_369 SERIES		HT_370 & 2_370 SERIES		HT_371 & 2_371 SERIES	
		HT_372 & 2_372 SERIES		HT_373 & 2_373 SERIES		HT_374 & 2_374 SERIES	
		HT_375 & 2_375 SERIES		HT_376 & 2_376 SERIES		HT_377 & 2_377 SERIES	
		HT_378 & 2_378 SERIES		HT_379 & 2_379 SERIES		HT_380 & 2_380 SERIES	
		HT_381 & 2_381 SERIES		HT_382 & 2_382 SERIES		HT_383 & 2_383 SERIES	
		HT_384 & 2_384 SERIES		HT_385 & 2_385 SERIES		HT_386 & 2_386 SERIES	
		HT_387 & 2_387 SERIES		HT_388 & 2_388 SERIES		HT_389 & 2_389 SERIES	
		HT_390 & 2_390 SERIES		HT_391 & 2_391 SERIES		HT_392 & 2_392 SERIES	
		HT_393 & 2_393 SERIES		HT_394 & 2_394 SERIES		HT_395 & 2_395 SERIES	
		HT_396 & 2_396 SERIES		HT_397 & 2_397 SERIES		HT_398 & 2_398 SERIES	
		HT_399 & 2_399 SERIES		HT_400 & 2_400 SERIES		HT_401 & 2_401 SERIES	
		HT_402 & 2_402 SERIES		HT_403 & 2_403 SERIES		HT_404 & 2_404 SERIES	
		HT_405 & 2_405 SERIES		HT_406 & 2_406 SERIES		HT_407 & 2_407 SERIES	
		HT_408 & 2_408 SERIES		HT_409 & 2_409 SERIES		HT_410 & 2_410 SERIES	
		HT_411 & 2_411 SERIES		HT_412 & 2_412 SERIES		HT_413 & 2_413 SERIES	
		HT_414 & 2_414 SERIES		HT_415 & 2_415 SERIES		HT_416 & 2_416 SERIES	
		HT_417 & 2_417 SERIES		HT_418 & 2_418 SERIES		HT_419 & 2_419 SERIES	
		HT_420 & 2_420 SERIES		HT_421 & 2_421 SERIES		HT_422 & 2_422 SERIES	
		HT_423 & 2_423 SERIES		HT_424 & 2_424 SERIES		HT_425 & 2_425 SERIES	
		HT_426 & 2_426 SERIES		HT_427 & 2_427 SERIES		HT_428 & 2_428 SERIES	
		HT_429 & 2_429 SERIES		HT_430 & 2_430 SERIES		HT_431 & 2_431 SERIES	
		HT_432 & 2_432 SERIES		HT_433 & 2_433 SERIES		HT_434 & 2_434 SERIES	
		HT_435 & 2_435 SERIES		HT_436 & 2_436 SERIES		HT_437 & 2_437 SERIES	
		HT_438 & 2_438 SERIES		HT_439 & 2_439 SERIES		HT_440 & 2_440 SERIES	
		HT_441 & 2_441 SERIES		HT_442 & 2_442 SERIES		HT_443 & 2_443 SERIES	
		HT_444 & 2_444 SERIES		HT_445 & 2_445 SERIES		HT_446 & 2_446 SERIES	
		HT_447 & 2_447 SERIES		HT_448 & 2_448 SERIES		HT_449 & 2_449 SERIES	
		HT_450 & 2_450 SERIES		HT_451 & 2_451 SERIES		HT_452 & 2_452 SERIES	
		HT_453 & 2_453 SERIES		HT_454 & 2_454 SERIES		HT_455 & 2_455 SERIES	
		HT_456 & 2_456 SERIES		HT_457 & 2_457 SERIES		HT_458 & 2_458 SERIES	
		HT_459 & 2_459 SERIES		HT_460 & 2_460 SERIES		HT_461 & 2_461 SERIES	
		HT_462 & 2_462 SERIES		HT_463 & 2_463 SERIES		HT_464 & 2_464 SERIES	
		HT_465 & 2_465 SERIES		HT_466 & 2_466 SERIES		HT_	

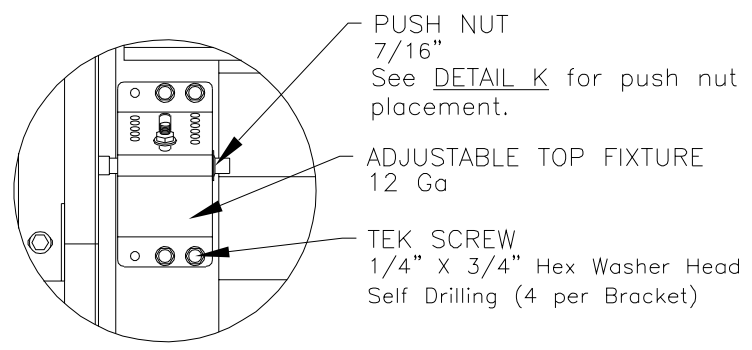

**DETAIL A**

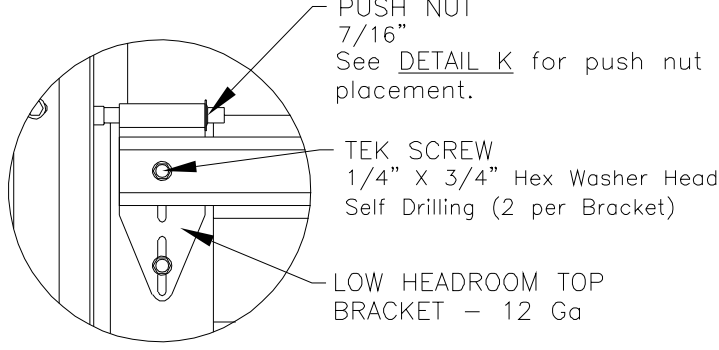

**LOW HEADROOM TOP BRACKET**

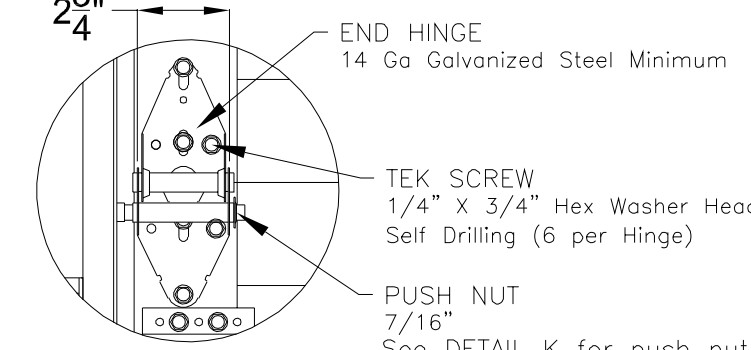

**DETAIL B**

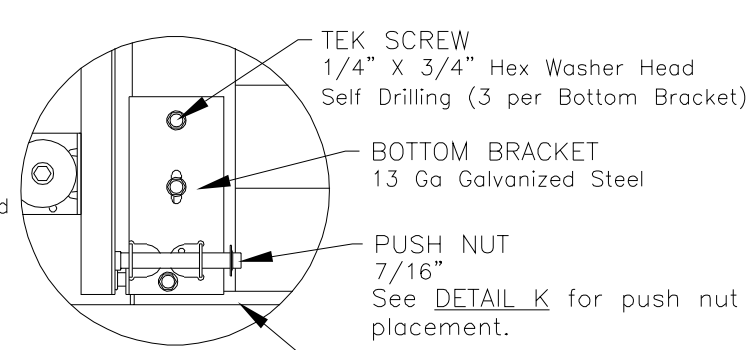

**DETAIL C**

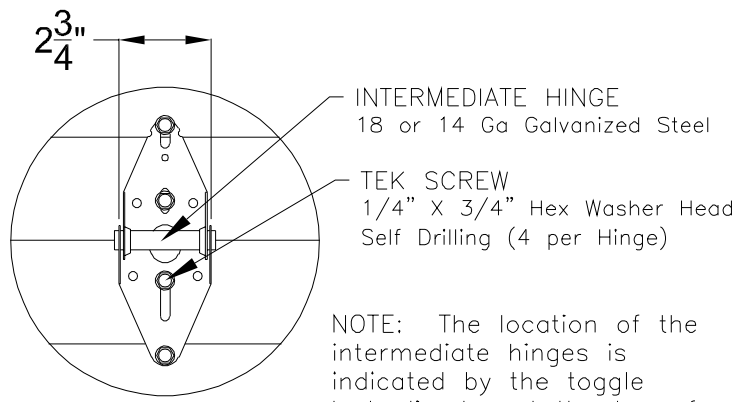

**DETAIL D**

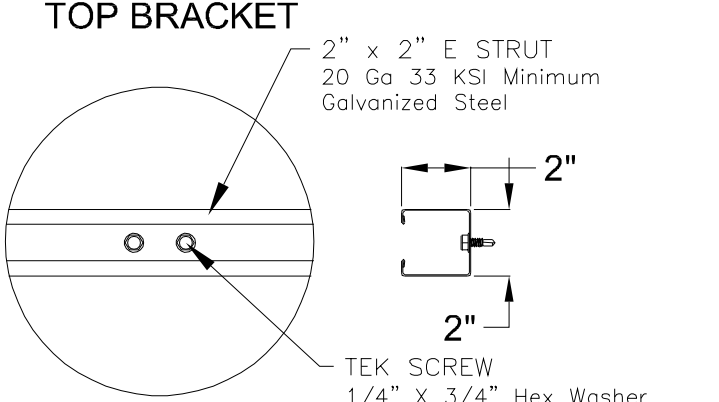

**DETAIL E**

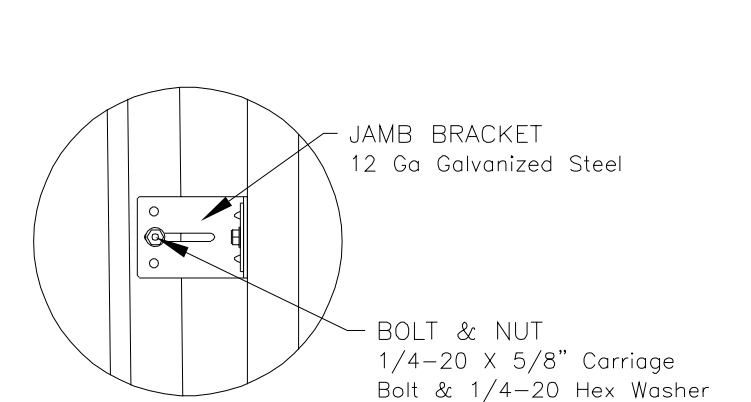

**DETAIL F**

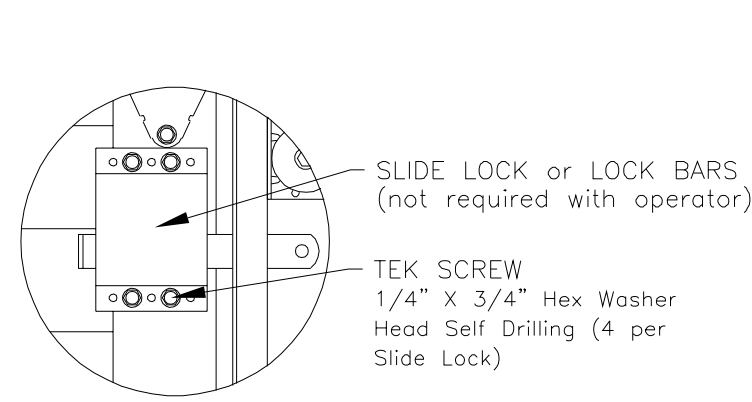

**DETAIL G**

NOTE: The location of the intermediate hinges is indicated by the toggle lock dimples at the top of each section.

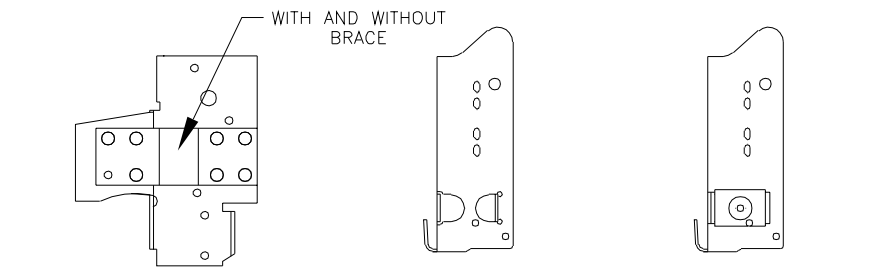

RESIDENTIAL & LIGHT COMMERCIAL For Low Headroom With 2" Track and Single End Stiles  
 COMMERCIAL For Standard, High & Vertical Lift With 2" Track and Single End Stiles  
 COMMERCIAL For Standard, High & Vertical Lift With 3" Track and Single End Stiles

**ALTERNATE BOTTOM BRACKETS**

NOTE: The bottom bracket tested (shown in DETAIL C) is the lightest bracket available.

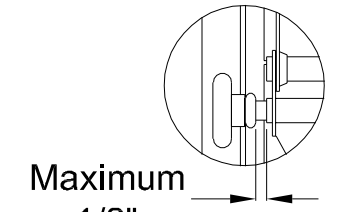

**DETAIL K**

There should be a space of maximum 1/2" between the roller hub and the outside edge of the roller holder which is set by the push nut.

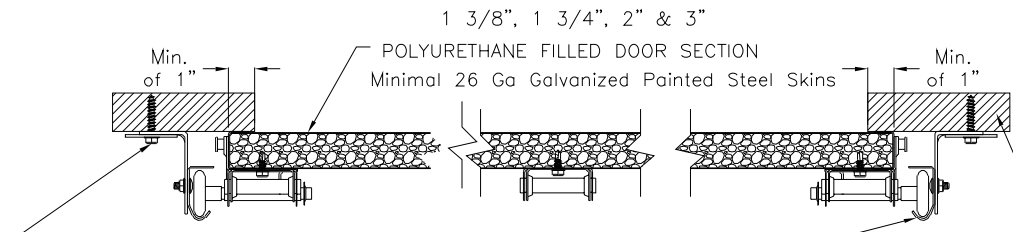

BOLT & WASHER 5/16" X 1 5/8" Lag Bolt & 2" O.D. x 7/16" I.D. Flat Washer  
 NOTE: Jamb bracket must be in direct contact with the 2x6 (No drywall allowed).  
 NOTE: The flat washer is not required for angle mount.  
 VERTICAL TRACK - 2" Nominal 13 Ga Galvanized Steel tested. 3" Nominal 13 Ga is also approved as an alternate.  
 WOOD JAMB  
 The vertical wood jamb fasteners may be counter sunk to provide a flat mounting surface. See jamb attachment details on sheet 3 for attaching jambs to the structure.

**ROLLER**

2" Diameter Nominal Eleven Ball Nylon or Ten Ball Steel with a Minimum Workable Shaft Length Shown.

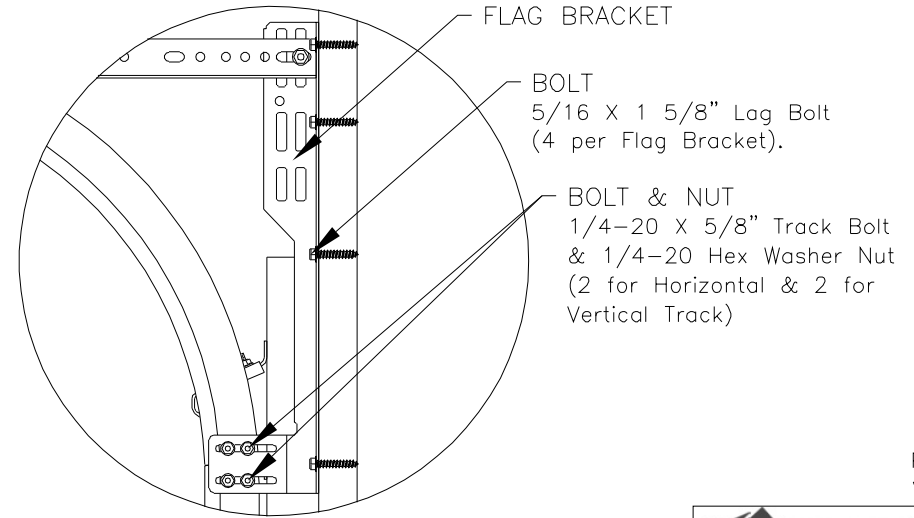

**DETAIL H**

NOTE: Details on some views omitted for clarity. Double end stiles and end hardware may be provided on wider or heavier doors.

John E. Scates, P.E.  
 2560 King Arthur Blvd. Ste 124-54  
 Lewisville, Texas 75056  
 Texas P.E. 56308/F2203

Professional Engineer seal provided only for verification of wind load construction details.

<p>320 Sycamore        Wauseon, Ohio 43567        © Copyright 2014</p>	<b>DESCRIPTION:</b> 9' 2" HT 600, 700, 2000, 800 & 900/9000 AMERICAN TRADITION SERIES W/LITES WIND LOAD SECTIONAL DOOR DESIGN PRESSURE +21.3/-24.1 PSF	
	<b>DRAWING NO.:</b> WLT-0600-0110-08-21-24L	<b>REV.:</b> A
	<b>DRAWN BY:</b> MVS	<b>DATE DRAWN:</b> 10/23/18
	<b>MODEL(S):</b> See Sheet 3	<b>REV. DATE:</b> 3/2/22
		<b>SHEET: 2 OF 4</b>

# MODEL NUMBERS AND IMPACT LITE OPTIONS

MODEL NUMBERS AVAILABLE	LITE OPTIONS AVAILABLE					
	CARRIAGE HOUSE	RANCH	STANDARD	LARGE COMMERCIAL 24 x 12	SMALL COMMERCIAL 24 x 6	AMERICAN TRADITION*
HT_14 & 2_14 SERIES				X	X	
HT_16 & 2_16 SERIES				X	X	
HT_32 & 2_32 SERIES				X	X	
HT_33 & 2_33 SERIES				X	X	
HT_10 & 2_10 SERIES	X	X	X	X	X	
HT_12 & 2_12 SERIES				X	X	
HT_60 & 2_60 SERIES	X					
HT_61 & 2_61 SERIES	X					
HT_63 & 2_63 SERIES	X					
HT_64 & 2_64 SERIES	X					
HT_67 & 2_67 SERIES	X					
HT_68 & 2_68 SERIES	X					
HT_69 & 2_69 SERIES	X					
HT_70 & 2_70 SERIES		X				
HT_71 & 2_71 SERIES		X				
HT_72 & 2_72 SERIES		X				
HT_73 & 2_73 SERIES		X				
HT_74 & 2_74 SERIES		X				
HT_78 & 2_78 SERIES		X				
HT_79 & 2_79 SERIES		X				
HT_80 & 2_80 SERIES			X			
HT_81 & 2_81 SERIES			X			
HT_82 & 2_82 SERIES			X			
HT_87 & 2_87 SERIES			X			
HT_90 & 2_90 SERIES			X			
American Tradition 900/9000 SERIES						X*
	38 1/2" x 12 1/2"	38 1/2" x 10 1/2"	17 1/2" x 10 1/2"	21 1/2" x 9 1/2"	21 1/2" x 3 1/4"	45" x 14 11/16"
	DAY LIGHT OPENING (DLO) - WIDE x TALL					

\* The American Tradition lite option is available in tempered or insulated glass units only. See the GLAZING DETAIL for the specifications.

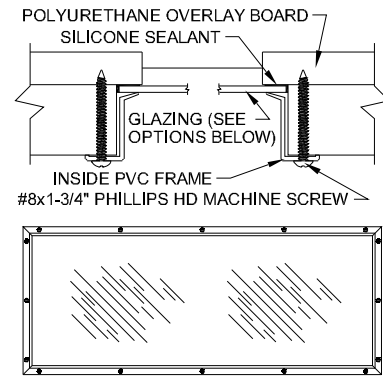

SCREW LOCATION - AM. TRADITION  
NOTE: 16 SCREWS USED.

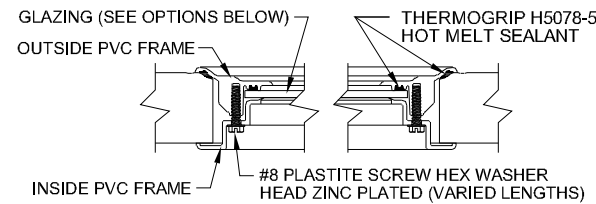

SCREW LOCATION - STANDARD LITE  
NOTE: 10 SCREWS USED.

SCREW LOCATION - CARRIAGE HOUSE & RANCH LITES  
NOTE: 18 SCREWS USED.

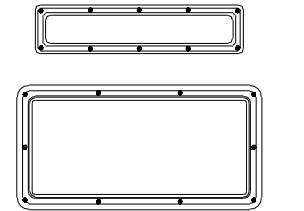

SCREW LOCATION - COMMERCIAL LITES  
NOTE: 10 SCREWS USED.

## GLAZING DETAIL

NOTE: GLAZING IS AVAILABLE IN 1/8" ANNEALED GLASS, 1/8" THICK TEMPERED GLASS, 1/2" INSULATED GLASS UNITS CONSISTING OF TWO PIECES OF 1/8" THICK TEMPERED GLASS AND A 1/4" SPACER, 1/8" ACRYLIC (SABIC INNOVATIVE PLASTICS) AND POLYCARBONATE (LEXAN OR MAKROLON/TUFFAK). THE DAY LIGHT OPENING (DLO) OF EACH LITE OPTION IS LISTED IN THE MODEL NUMBERS AND LITE OPTIONS CHART ON SHEET 3 OF 4.

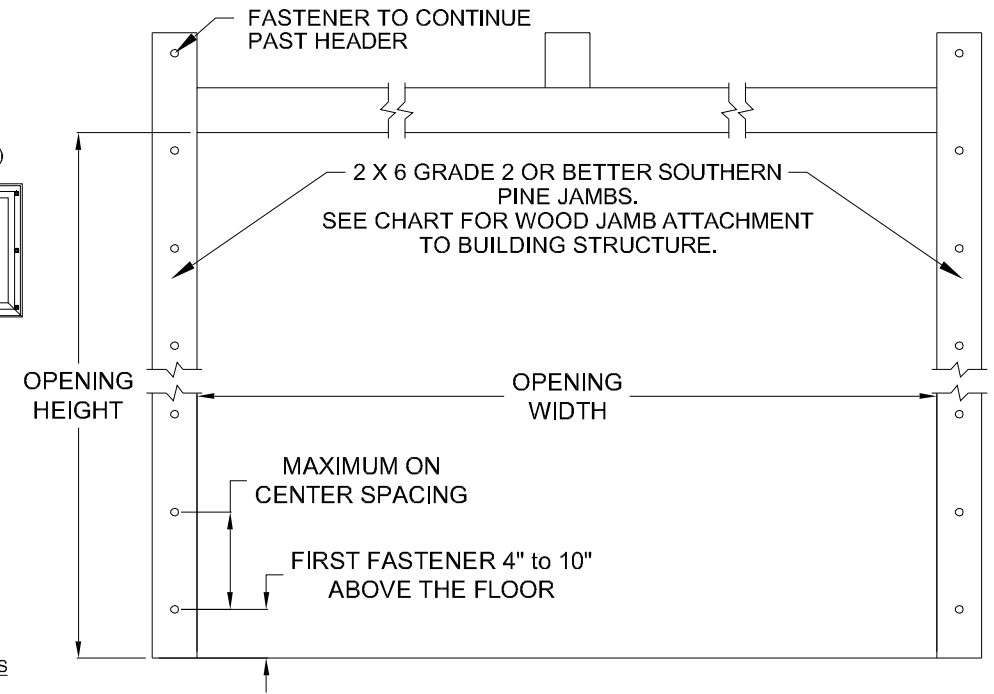

WOOD JAMB ATTACHMENT						
Building Structure	Fastener Type	Minimum Embedment	Minimum Edge Distance	Minimum on Center Spacing	Maximum on Center Spacing	Allowable Tension Load
Min. 2500 PSI to 4000 PSI Concrete	Tapcon + (PLUS) 1/4" w/ 1" OD washer	2"	2.50"	5.00"	24"	551
Southern Pine	3/8" Lag w/ 1 1/8" OD washer	1.50"	1.50"	1.50"	24"	620
Spruce Pine Fir	3/8" Lag w/ 1 1/8" OD washer	1.50"	1.50"	1.50"	24"	482

NOTE: 2X6 mounted to the wall must be Southern Pine Grade 2 or better.

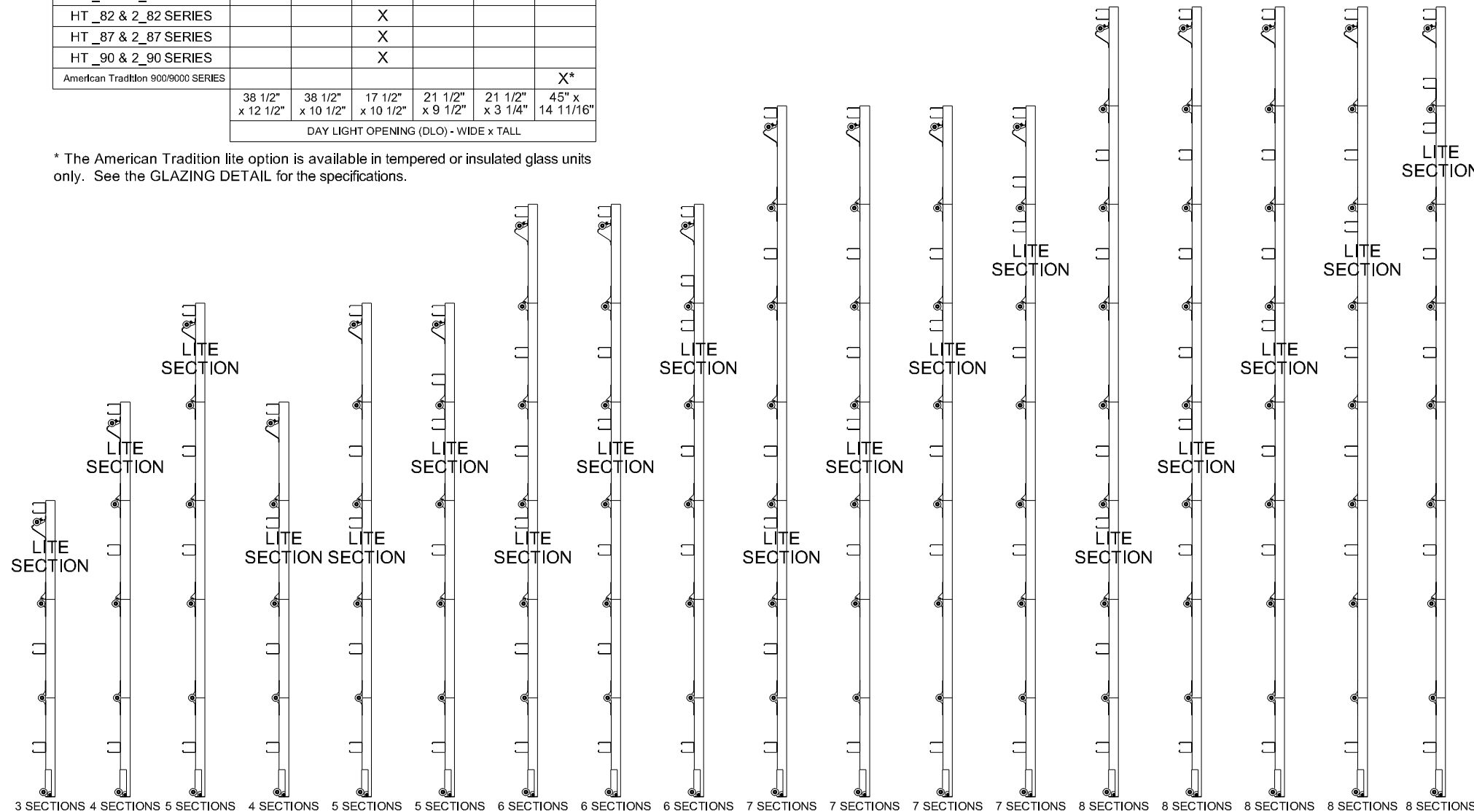

## STRUT CONFIGURATION

John E. Scates, P.E.  
2560 King Arthur Blvd. Ste 124-54  
Lewisville, Texas 75056  
Texas P.E. 56308/F2203

Professional Engineer seal provided only for verification of wind load construction details.



**DESCRIPTION:**  
9' 2" HT 600, 700, 2000, 800 & 900/9000 AMERICAN TRADITION SERIES W/LITES WIND LOAD SECTIONAL DOOR DESIGN PRESSURE +21.3/-24.1 PSF

**DRAWING NO.:** WLT-0600-0110-08-21-24L **REV.:** A

**DRAWN BY:** MVS **DATE DRAWN:** 10/23/18 **REV. DATE:** 3/2/22

**MODEL(S):** See Sheet 3 **SHEET: 3 OF 4**

320 Sycamore  
Wauseon, Ohio 43567  
© Copyright 2014

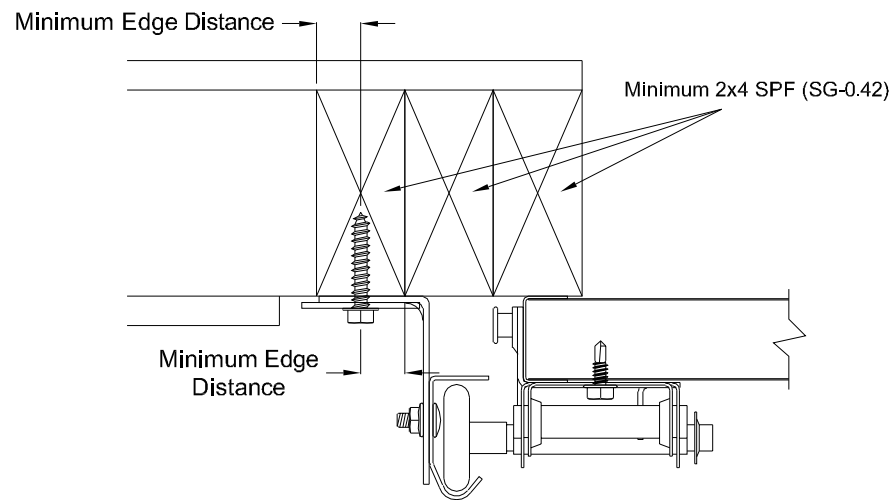

### Direct Wood Mounting Detail

Bracket Mount Shown, Reverse and Continuous Angle Mount Also Approved As Alternate.

439 lbs. per anchor allowable load  
 5/16" Dia. Lag Screw w/1-1/8" O.D. Flat Washer (shall conform to ANSI/ASME standard B18.2.1)  
 Minimum Screw Length: Spruce-Pine-Fur (SPF) - 2-1/2"  
 Southern Pine - 1-5/8"  
 Minimum Edge Distance: 1/2"  
 Maximum on Center Spacing: 24"

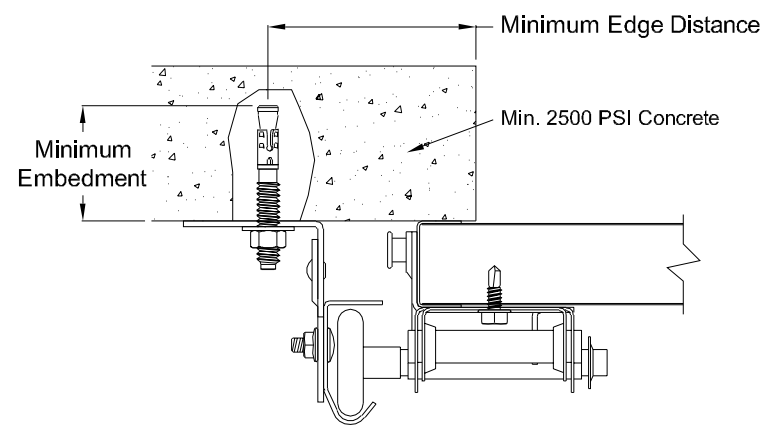

### Direct Concrete Mounting Detail

Continuous Angle Clip Mount Shown, Bracket and Reverse Continuous Angle Mount Also Approved As Alternate.

831 lbs. per anchor allowable load  
 3/8" Dia. Ankr-Tite CCAT w/1-1/8" O.D. Flat Washer (by Wej-It Fastening Systems)  
 Minimum Embedment: 2-5/8"  
 Minimum Edge Distance: 2-1/2"  
 Minimum on Center Spacing: 6"  
 Maximum on Center Spacing: 24"

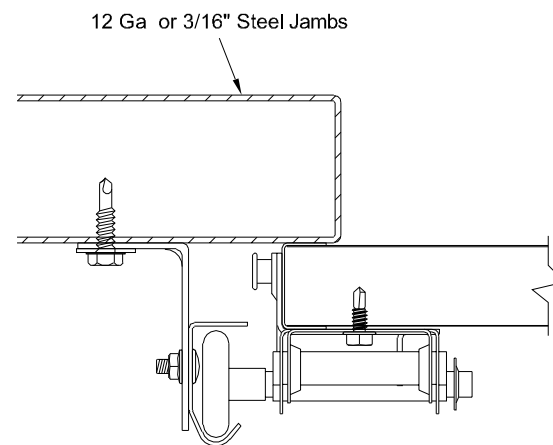

### Direct Steel Mounting Detail

Bracket Mount Shown, Reverse and Continuous Angle Mount Also Approved As Alternate.

232 lbs. per anchor allowable load - 12 Ga Ste569el  
 lbs. per anchor allowable load - 3/16" Ga Steel  
 5/16"-12 Tek Self-Drilling Screw w/9/16" O.D. Flat Washer  
 12 Ga Maximum on Center Spacing: 24"  
 3/16" Maximum on Center Spacing: 24"

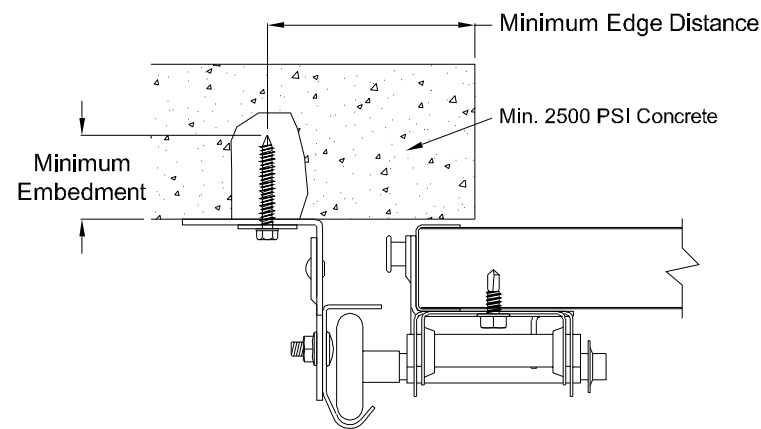

### Direct Concrete Mounting Detail

Continuous Angle Clip Mount Shown, Bracket and Reverse Continuous Angle Mount Also Approved As Alternate.

562 lbs. per anchor allowable load  
 1/4" Dia. Concrete Self-Tapping & Wedge Anchor w/1" O.D. Flat Washer (Includes Tapcon+ (by ITW), Wedge-Bolt+ (by Powers Fasteners) & Red Head TruBolt wedge anchor (by ITW))  
 Minimum Embedment: 2"  
 Minimum Edge Distance: 2-1/2"  
 Minimum on Center Spacing: 5"  
 Maximum on Center Spacing: 24"

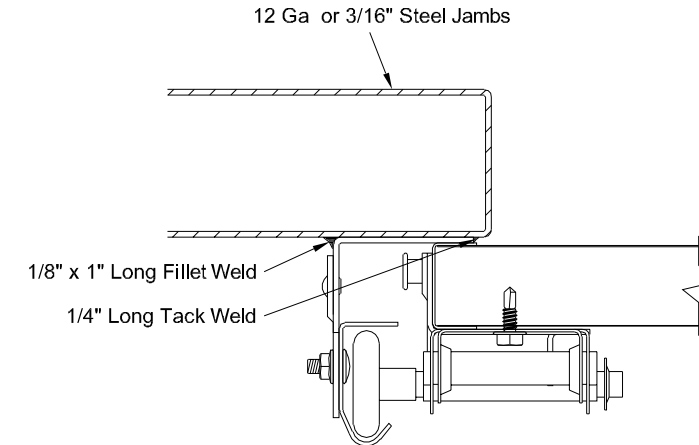

### Direct Steel Mounting Detail

Reverse Continuous Angle Clip Mount Shown, Continuous Angle Mount Also Approved As Alternate.

1272 lbs. per anchor allowable load  
 1/8" Nom. x 1" Long Fillet and 1/4" Long Tack Weld (E60xx Electrodes Min.)  
 Welds performed by a certified welder or inspected by a certified welding inspector to verify integrity of the welds.  
 Maximum on Center Spacing: Apply welds at each roller location not to exceed 24"

John E. Scates, P.E.  
 2560 King Arthur Blvd. Ste 124-54  
 Lewisville, Texas 75056  
 Texas P.E. 56308/F2203

Professional Engineer seal provided only for verification of wind load construction details.



**DESCRIPTION:**  
 9' 2" HT 600, 700, 2000, 800 & 900/9000 AMERICAN TRADITION SERIES W/LITES WIND LOAD SECTIONAL DOOR  
 DESIGN PRESSURE +21.3/-24.1 PSF

**DRAWING NO.:** WLT-0600-0110-08-21-24L **REV.:** A

**DRAWN BY:** MVS **DATE DRAWN:** 10/23/18 **REV. DATE:** 3/2/22

**MODEL(S):** See Sheet 3 **SHEET: 4 OF 4**

320 Sycamore  
 Wauseon, Ohio 43567  
 © Copyright 2014