

MODELS AVAILABLE (CLOPAY/ HOLMES/ IDEAL)
 MODELS 524, 520/ 224/ C4ST, C0ST
 INSULATED MODELS 524S, 520S, 524V/ 224S/ C4SS, C0SS, C4SV

REVISIONS					
REV. NO.	ZONE:	DATE:	ECN NO.	APPVD:	DESCRIPTION
00	-	2/2/17	-	-	INITIAL RELEASE
01	-	02/2022	-	JDW	REVISED FOR TDI.

THIS PRODUCT COMPLIES WITH THE 2018 IBC/IRC.

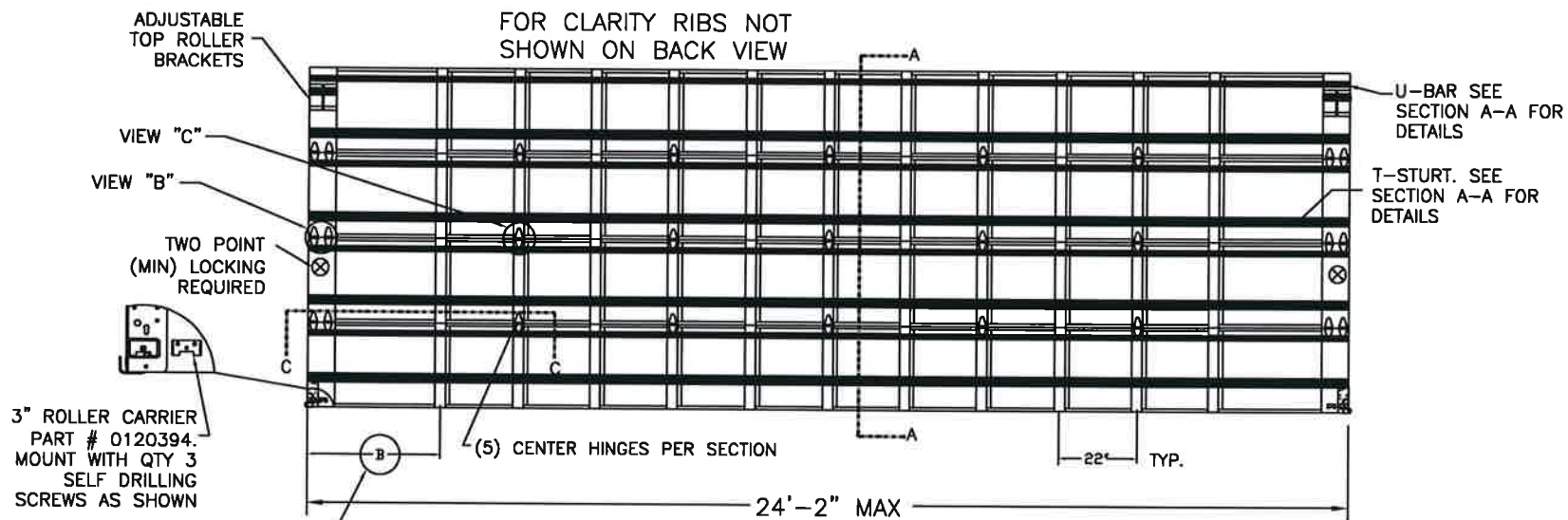

NOTE:
 CENTER STILES ARE ALWAYS 22" FROM CENTER TO CENTER. FOR ANY GIVEN DOOR WIDTH, DIMENSION 'B' IS THE LEFTOVER DIMENSION TO BOTH ENDS OF THE DOOR. THE MAXIMUM TESTED FULL VISION PANEL SIZE IS 23" X 24".

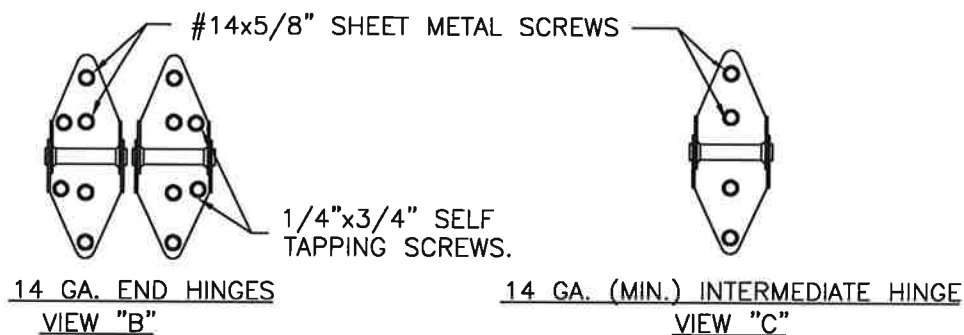

DOOR WIDTH	NUMBER OF CENTER STILES/ HINGES	NUMBER OF EXTRA STILES
20'-3" THRU 24'-2"	5	6

DOOR HEIGHT 'A'	NUMBER OF SECTIONS
UP TO 8'-0"	4
8'-3" THRU 10'-0"	5
10'-3" THRU 12'-0"	6
12'-3" THRU 14'-0"	7
14'-3" THRU 16'-0"	8
16'-3" THRU 18'-0"	9

Handwritten signature and date: 5/31/22
 MARK A. WESTERFIELD
 91513
 PROFESSIONAL ENGINEER
 END STILE
 SLIDE BOLT LOCK ENGAGES INTO VERTICAL TRACK. ONE LOCK ON EACH SIDE OF DOOR.
 INSIDE SLIDE BOLT LOCK OPTION.

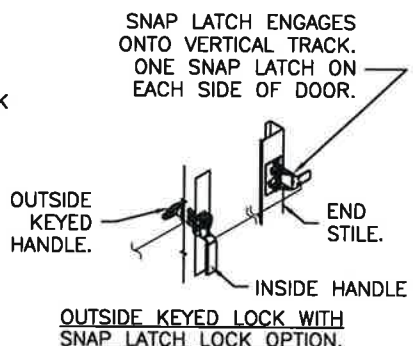

DESIGN LOADS: +25 & -25 P.S.F.
 TEST LOADS: +37.5 & -37.5 P.S.F.

Unless Stated Otherwise
 TOLERANCES are
 .0 = ±.031
 .00 = ±.015
 .000 = ±.005
 .0000 = ±.001
 Degrees = ±1/2"

Clopay CORPORATION
 8585 Duke Boulevard
 Mason, OH 45040 USA
 Tel. No. 513-770-4800
 Fax No. 513-770-4853

MANUFACTURING PRODUCT CODE:
 MPC: C-PAN-1E448

PART NO.: N/A

CLOPAY WINDLOAD RATING
 W4

DESCRIPTION: COMMERCIAL RIBBED DOOR, +25/-25 PSF DESIGN LOAD

DRAWN BY: RJH	DATE: 2/2/17	SCALE: NTS	DWG. SIZE B
CHECKED BY: -	DATE: -	SHEET 1 OF 4	
DWG. NO.: 105196	VER: TDI		

MARK WESTERFIELD, P.E.
 FLORIDA P.E. No. 48495,
 NC P.E. #23832, TEXAS P.E. #91513

MODELS AVAILABLE (CLOPAY/ HOLMES/ IDEAL)
 MODELS 524, 520/ 224/ C4ST, C0ST
 INSULATED MODELS 524S, 520S, 524V/ 224S/ C4SS, C0SS, C4SV

REVISIONS					
REV. NO.	ZONE:	DATE:	ECN NO.	APPVD:	DESCRIPTION
01	-	-	-	-	SEE REVISION HISTORY ON SHEET 1

JAMB TO SUPPORTING STRUCTURE ATTACHMENT

- NOTES:**
1. ALL THE LOAD FROM THE DOOR IS TRANSFERRED TO THE TRACK AND THEN FROM THE TRACK TO THE 2x6 VERTICAL SYP (GRADE #2 OR BETTER) JAMBS. NO LOAD FROM THE DOOR IS TRANSFERRED TO THE HORIZONTAL (TOP) JAMB.
 2. EACH VERTICAL JAMB SEES A MAXIMUM DESIGN LOAD OF +300 LB & -300 LB. PER LINEAR FOOT OF JAMB.
 3. ALL JAMB FASTENERS MAY BE (BUT ARE NOT REQUIRED TO BE) COUNTERSUNK TO PROVIDE A FLUSH MOUNTING SURFACE.
 4. A 1/3 STRESS INCREASE FOR WIND LOAD WAS NOT USED IN THE CALCULATION OF ALLOWABLE LOADS FOR ANCHORS AND FASTENERS FOR STEEL, CONCRETE AND MASONRY.

NOTE: 2x6 WOOD JAMBS ARE NOT REQUIRED WITH CONTINUOUS ANGLE MOUNT TRACK. HOWEVER, IF DESIRED ON STEEL JAMBS OR CONCRETE OR BLOCK WALLS, APPROVED FASTENERS AS DETAILED BELOW SHOULD BE INCREASED IN LENGTH BY 1-1/2" AND INSTALLED DIRECTLY THROUGH THE ANGLE AND 2x6 WOOD JAMBS INTO THE STEEL JAMBS OR CONCRETE OR BLOCK WALLS. ANCHORS CAN BE (BUT ARE NOT REQUIRED TO BE) COUNTERSUNK TO PROVIDE A FLUSH MOUNTING SURFACE. CONTINUOUS ANGLE TRACK CAN BE ANCHORED DIRECTLY TO GROUT REINFORCED BLOCK WALL OR 3,000 PSI MIN. CONCRETE COLUMN OR STEEL JAMBS.

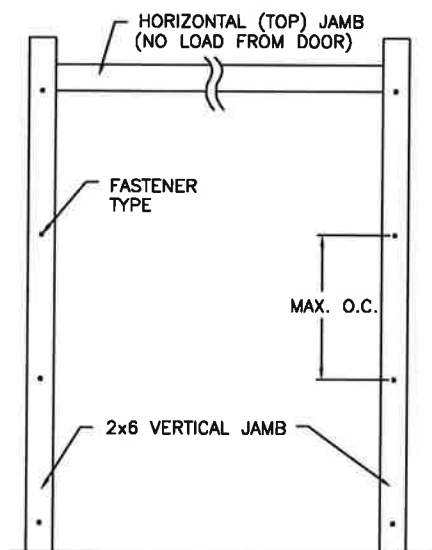

FASTENER ATTACHMENT TO SUPPORTING STRUCTURE SCHEDULES

BUILDING TYPE	FASTENER TYPE	MAXIMUM ON-CENTER DISTANCE BETWEEN FASTENERS*	STEEL WASHERS REQUIRED?
HOLLOW BLOCK WALL	1/4" x 1-1/4" MIN. EMBED ULTRACON CONCRETE ANCHOR	5-1/2"	1" O.D.
GROUT FILLED BLOCK WALL	1/4" x 1-3/4" MIN. EMBED ULTRACON CONCRETE ANCHOR	9"	1" O.D.
2000 PSI MIN. CONCRETE	1/4" x 1" MIN. EMBED ULTRACON CONCRETE ANCHOR	8"	1" O.D.
2000 PSI MIN. CONCRETE	1/4" x 1" MIN. EMBED TAPCON CONCRETE ANCHOR	7-1/2"	1" O.D.
2000 PSI MIN. CONCRETE	3/8" x 1-3/4" MIN. EMBED WEJ-IT ANKR TITE SLEEVE ANCHOR	16-3/4"	INCLUDED
4000 PSI MIN. CONCRETE	3/8" x 1-3/4" MIN. EMBED WEJ-IT ANKR TITE SLEEVE ANCHOR	24"	INCLUDED
WOOD FRAME (SYP 0.55 SG)	1/2" x 3" LAG SCREW (ASTM A307, GRADE A) 1-5/8" EMBED INTO STRUCTURE	18"	1" O.D.
14GA STEEL (0.060" MIN.)	1/4"-14 x 1" ITW BUILDDEX TEKS SELF-DRILLING FASTENER	7-1/2"	1" O.D.
12GA STEEL (0.105" MIN.)	1/4"-14 x 1" ITW BUILDDEX TEKS SELF-DRILLING FASTENER	13-1/4"	1" O.D.
1/8" STEEL	1/4"-14 x 1" ITW BUILDDEX TEKS SELF-DRILLING FASTENER	15-3/4"	1" O.D.

* FIRST (BOTTOM) ANCHOR STARTING AT NO MORE THAN HALF OF THE MAXIMUM ON-CENTER DISTANCE. HIGHEST ANCHOR INSTALLED AT LEAST AS HIGH AS THE DOOR OPENING.
 CLOPAY DOES NOT SUPPLY JAMB ATTACHMENT FASTENERS.
 MINIMUM DISTANCE BETWEEN CENTER OF ANCHOR AND EDGE OF CONCRETE BLOCK: 2-1/2", EXCLUDING STUCCO THICKNESS.

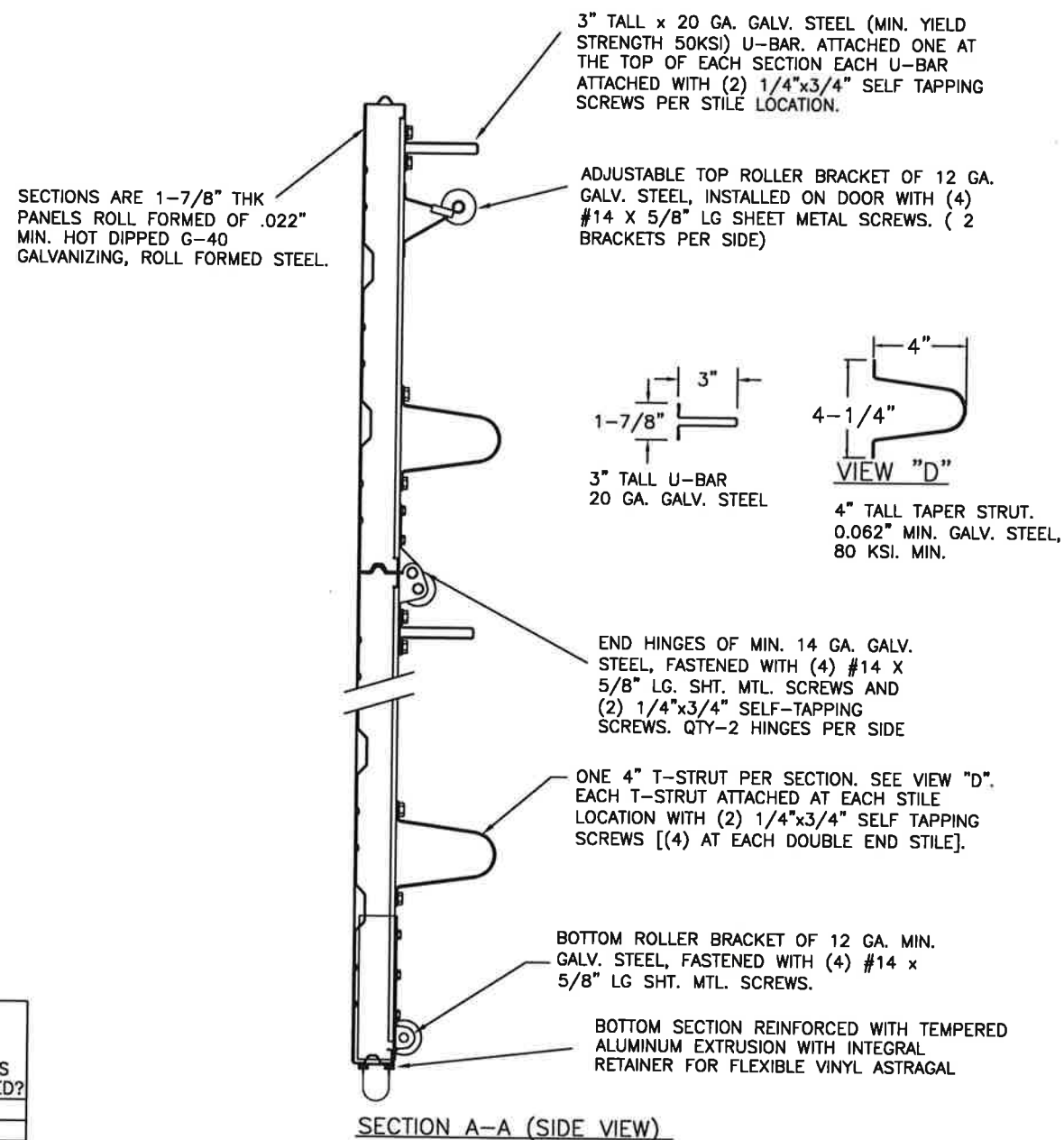

SECTION A-A (SIDE VIEW)

DESIGN LOADS: +25 & -25 P.S.F.
 TEST LOADS: +37.5 & -37.5 P.S.F.

Unless Stated Otherwise
 TOLERANCES are
 .0 = ±.031
 .00 = ±.015
 .000 = ±.005
 .0000 = ±.001
 Degrees = ±1/2"
 Unless Stated Otherwise
 DIMENSIONS ARE IN INCHES.

Glopay CORPORATION
 8585 Duke Boulevard
 Mason, OH 45040 USA
 Tel. No. 513-770-4800
 Fax No. 513-770-4853

MANUFACTURING PRODUCT CODE:
 MPC: C-PAN-1E448

PART NO.: N/A

CLOPAY WINDLOAD RATING
W4

DESCRIPTION: COMMERCIAL RIBBED DOOR, +25/-25 PSF DESIGN LOAD

DRAWN BY: RJH DATE: 2/2/17 SCALE: NTS DWG. SIZE: B

CHECKED BY: - DATE: - SHEET 2 OF 4

DWG. NO.: 105196 VER: TDI

STATE OF TEXAS
 MARK WESTERFIELD, P.E.
 5/31/22 91513
 MARK WESTERFIELD, P.E.
 FLORIDA P.E. No. 48495,
 NC P.E. #23832, TEXAS P.E. #91513

MODELS AVAILABLE (CLOPAY/ HOLMES/ IDEAL)
 MODELS 524, 520/ 224/ C4ST, C0ST
 INSULATED MODELS 524S, 520S, 524V/ 224S/ C4SS, C0SS, C4SV

REVISIONS					
REV. NO.	ZONE:	DATE:	ECN NO.	APPVD:	DESCRIPTION
01	-	-	-	-	SEE REVISION HISTORY ON SHEET 1

3" TRACK CONFIGURATION.

NOTE DOUBLE TRACK LOW HEADROOM, HI-LIFT TRACK, FOLLOW-THE-ROOF TRACK, AND VERTICAL LIFT TRACK ARE AVAILABLE OPTIONS. TRACK CONFIGURATION ABOVE THE DOOR OPENING DOES NOT AFFECT THE WIND LOAD RATING.

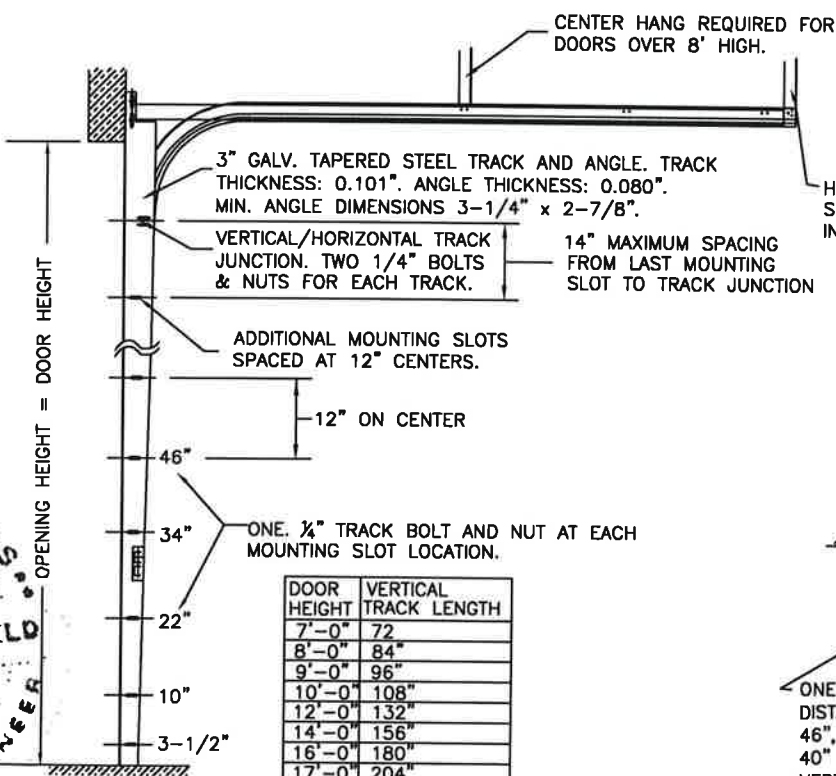

DOOR HEIGHT	VERTICAL TRACK LENGTH
7'-0"	72"
8'-0"	84"
9'-0"	96"
10'-0"	108"
12'-0"	132"
14'-0"	156"
16'-0"	180"
17'-0"	204"
18'-0"	228"

JAMB CONFIGURATION FOR DOORS WITH 3" TRACK.

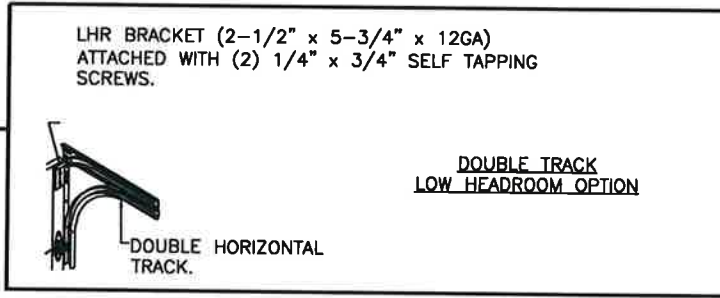
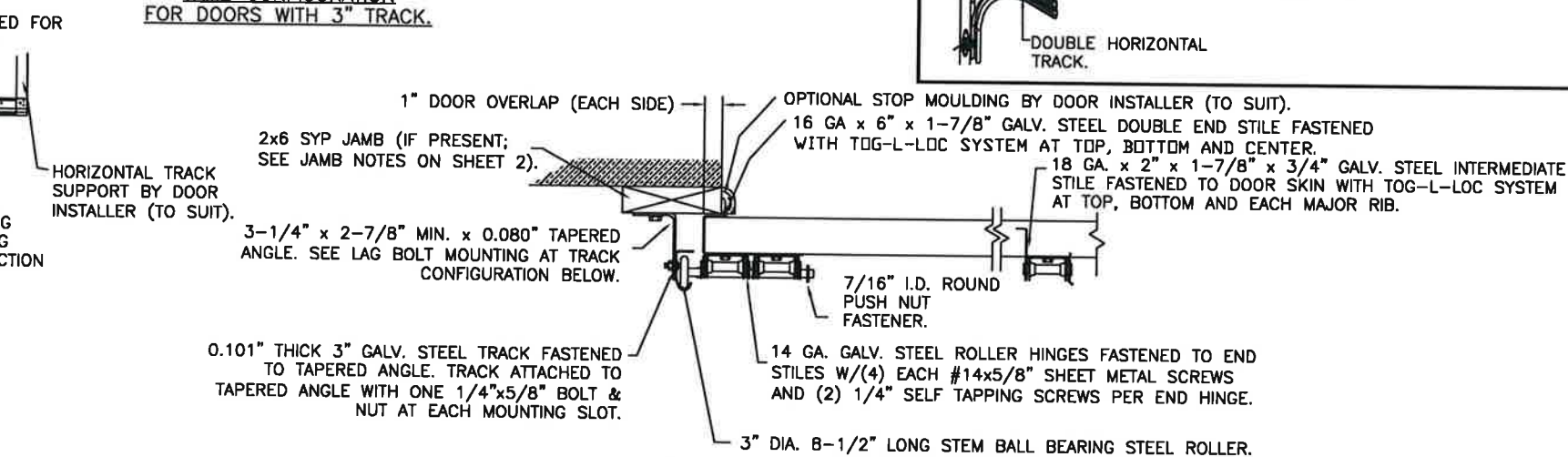

SECTION C-C PREPARATION OF JAMBS BY OTHERS.

DESIGN LOADS: +25 & -25 P.S.F.
 TEST LOADS: +37.5 & -37.5 P.S.F.

Unless Stated Otherwise
TOLERANCES are
 .0 = ±.031
 .00 = ±.015
 .000 = ±.005
 .0000 = ±.001
 Degrees = ±1/2"
 Unless Stated Otherwise
 DIMENSIONS ARE IN INCHES.

Glopay CORPORATION
 8585 Duke Boulevard
 Mason, OH 45040 USA
 Tel. No. 513-770-4800
 Fax No. 513-770-4853

MANUFACTURING PRODUCT CODE:
 MPC: C-PAN-1E448

PART NO.: N/A

CLOPAY WINDLOAD RATING
W4

DESCRIPTION: COMMERCIAL RIBBED DOOR, +25/-25 PSF DESIGN LOAD

DRAWN BY: RJH DATE: 2/2/17 SCALE: NTS DWG. SIZE **B**

CHECKED BY: - DATE: - SHEET 3 OF 4 VER: TDI
 DWG. NO.: 105196

MARK WESTERFIELD, P.E.
 FLORIDA P.E. No. 48495,
 NC P.E. #23832, TEXAS P.E. #91513

STATE OF TEXAS
 WESTERFIELD
 5/31/22
 ENGINEER

MODELS AVAILABLE (CLOPAY/ HOLMES/ IDEAL)
 MODELS 524, 520/ 224/ C4ST, C0ST
 INSULATED MODELS 524S, 520S, 524V/ 224S/ C4SS, C0SS, C4SV

REVISIONS					
REV. NO.	ZONE	DATE	ECN NO.	APPVD:	DESCRIPTION
01	-	-	-	-	SEE REVISION HISTORY ON SHEET 1

THE OPTIONAL GLAZING SHOWN ON THIS DRAWING MEETS THE WIND LOAD REQUIREMENTS OF THE FLORIDA BUILDING CODE OR INTERNATIONAL BUILDING CODE BUT DOES NOT MEET THE IMPACT RESISTANT REQUIREMENT FOR WINDBORNE DEBRIS REGIONS (REF. CHAPTER 16 FBC/IBC)

STANDARD ASSEMBLY CONSTRUCTION:
 OPTIONAL LITES WITH DSB OR BETTER GLAZING AVAILABLE. OPTIONAL FULL VISION SECTIONS WITH DSB OR BETTER GLAZING AVAILABLE.
 THE ENTIRE DOOR ASSEMBLY INSTALLED IN COMPLIANCE WITH THIS SECTION MEETS THE WIND LOAD REQUIREMENTS OF THE FLORIDA BUILDING CODE OR INTERNATIONAL BUILDING CODE BUT DOES NOT MEET THE IMPACT RESISTANT REQUIREMENT FOR WINDBORNE DEBRIS REGIONS (REF. CHAPTER 16 FBC/IBC).

NON-IMPACT-RESISTANT
FULL VISION SECTION OPTION

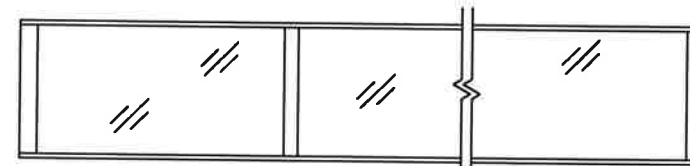

OPTIONAL ALUMINUM FULL VISION WINDOW LITE SECTIONS AVAILABLE, SINGLE PANE OR INSULATED. ALL PANES ANNEALED GLASS OR STRONGER. SINGLE PANES 1/8" OR THICKER. INSULATED WINDOWS 1/2" THICK, CONSISTING OF (2) PANES 1/8" THICK. FULL VISION SECTIONS TO HAVE SAME REINFORCEMENT AS OTHER SECTIONS. OPTIONAL ACRYLIC IS PLASKOLITE OPTIX, AN APPROVED CC2 PLASTIC IN COMPLIANCE WITH IBC/FBC 2606. MAXIMUM DLO: 33" X 21-1/4".

STANDARD ASSEMBLY DETAILS

Mark Westerfield
 5/31/22

 MARK WESTERFIELD, P.E.
 FLORIDA P.E. No. 48495,
 NC P.E. #23832, TEXAS P.E. #91513

DESIGN LOADS: +25 & -25 P.S.F.
 TEST LOADS: +37.5 & -37.5 P.S.F.

Unless Stated Otherwise
 TOLERANCES are
 .0 = ±.031
 .00 = ±.015
 .000 = ±.005
 .0000 = ±.001
 Degrees = ±1/2"

Unless Stated Otherwise
 DIMENSIONS ARE IN INCHES.

Clopay CORPORATION
 8585 Duke Boulevard
 Mason, OH 45040 USA
 Tel. No. 513-770-4800
 Fax No. 513-770-4853

DESCRIPTION: COMMERCIAL RIBBED DOOR, +25/-25 PSF DESIGN LOAD

DRAWN BY: RJH

DATE: 2/2/17

SCALE: NTS

DWG. SIZE B

CHECKED BY: -

DATE: -

SHEET 4 OF 4

DWG. NO.: 105196

VER: TDI

MANUFACTURING PRODUCT CODE:
 MPC: C-PAN-1E448

PART NO.: N/A

CLOPAY WINDLOAD RATING
 W4