

CLOPAY / IDEAL / HOLMES			
3717	/ C7X17 /	--	/ 27GA 1.75" THICK MINOR RIB
3718	/ C7X18 /	--	/ 27GA 1.75" THICK FLUSH
3720	/ C7X20 /	240U	/ 27GA 2" THICK MINOR RIB
3722	/ COX22 /	--	/ 20GA 2" THICK FLUSH
3724	/ C7X24 /	244U	/ 24GA 2" THICK MINOR RIB
3730	/ -- /	--	/ 27GA 3" THICK MINOR RIB

SHEET:  
1 OF 4

REVISIONS					
REV. NO.	ZONE	DATE	ECN NO.	APPVD:	DESCRIPTION
02	-	08/2016	-	SH	REMOVED WIND SPEED TABLE.
03	-	02/2021	-	JDW	ADDED 3" DOOR MODEL 3730..
04	-	02/2022	-	JDW	REVISED FOR TDI.

OPTIONAL GLAZING MAY BE STANDARD OR IMPACT RESISTANT GLAZING. MAXIMUM GLAZING SIZE (DLO) IS 21-5/8" x 9-5/8". GLAZING MAY BE INSTALLED IN TOP SECTION (NOT SHOWN) OR INTERMEDIATE SECTION (SHOWN). SEE SHEET 2 FOR ADDITIONAL DETAILS.

(1) 20 GA. GALV. STEEL BACKER PLATE AT EACH INTERMEDIATE HINGE LOCATION. BACKER PLATE ATTACHED WITH DOUBLE SIDED ACRYLIC ADHESIVE TO BACK OF DOOR.

16 GA. DOUBLE END STILE

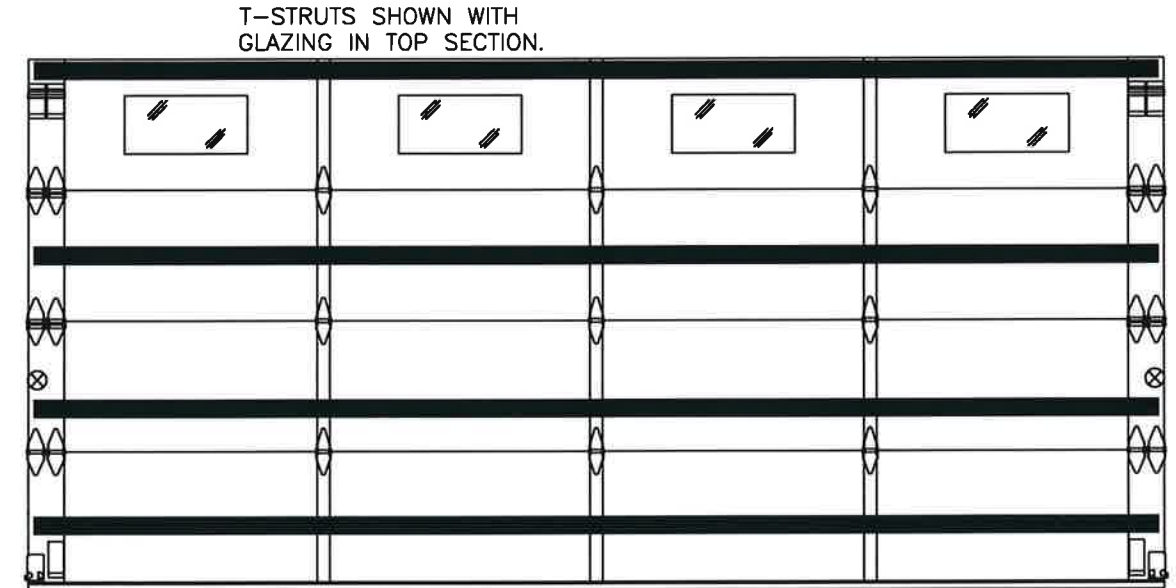
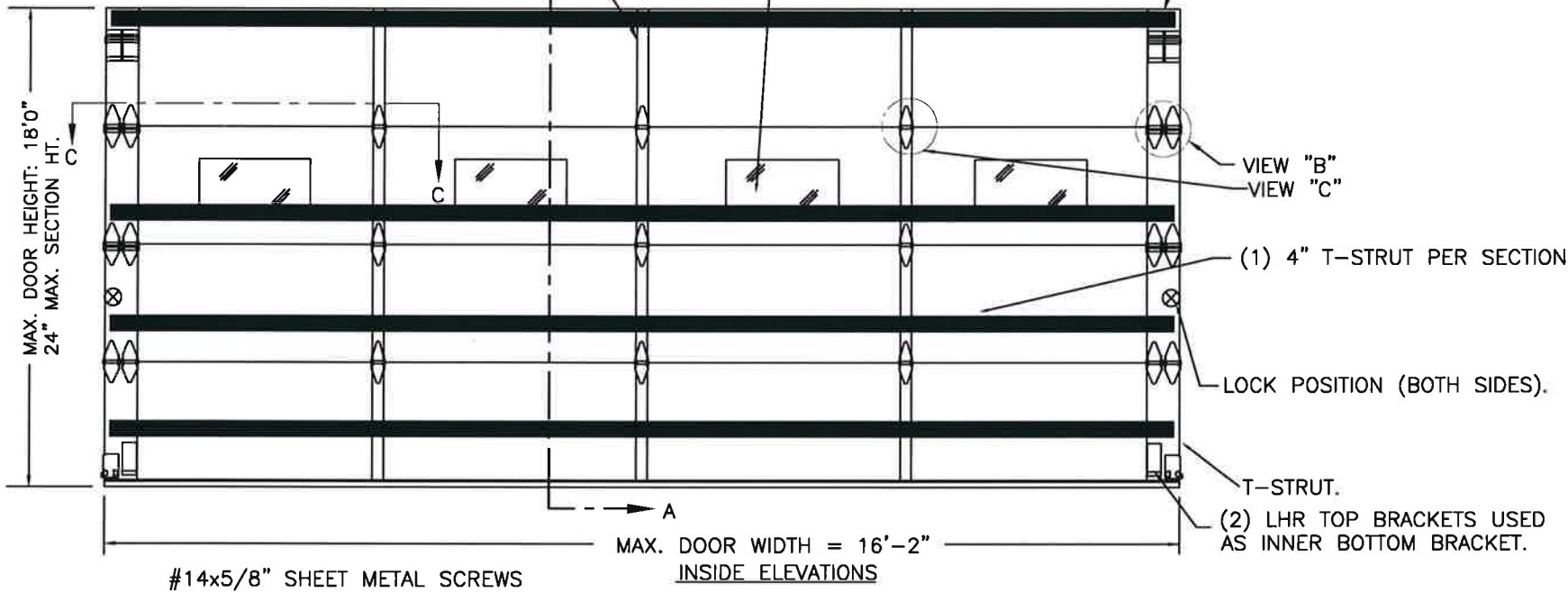

THIS PRODUCT COMPLIES WITH THE 2018 IBC/IRC.

DOOR HEIGHT 'A'	NUMBER OF SECTIONS
UP TO 8'-0"	4
8'-3" THRU 10'-0"	5
10'-3" THRU 12'-0"	6
12'-3" THRU 14'-0"	7
14'-3" THRU 16'-0"	8
16'-3" THRU 18'-0"	9

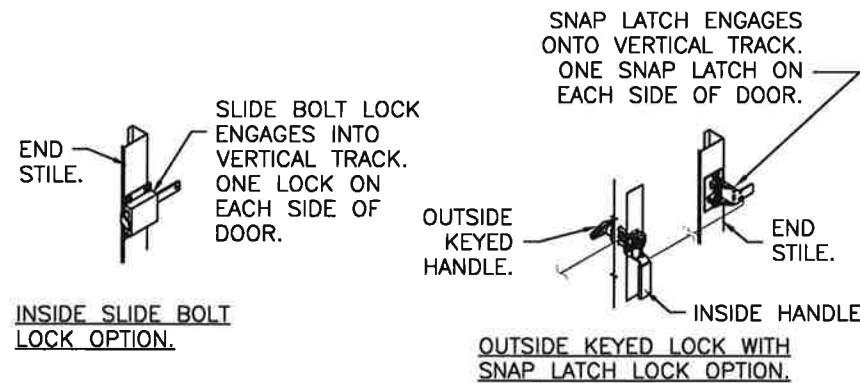
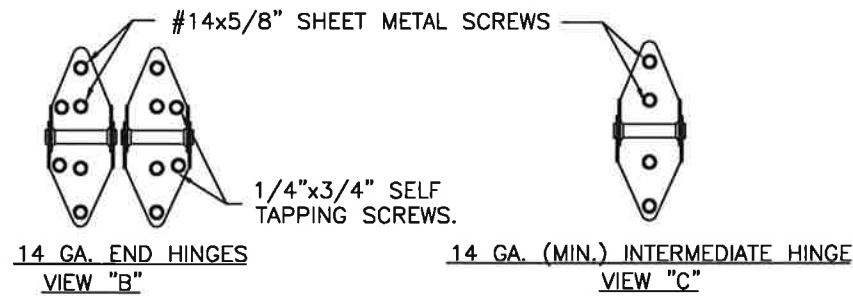

DESIGN LOADS: 37.0 P.S.F. - 42.0 P.S.F.  
TEST LOADS: 55.5 P.S.F. & 63.0 P.S.F.

5/31/22

Unless Stated Otherwise TOLERANCES are  
.0 = ±.0313  
.00 = ±.015  
.000 = ±.005  
.0000 = ±.001  
Degrees = ±.142

Unless Stated Otherwise DIMENSIONS ARE IN INCHES.

**Clopay** CORPORATION  
8585 Duke Boulevard  
Mason, OH 45040 USA  
Tel. No. 513-770-4800  
Fax No. 513-770-4853

MANUFACTURING PRODUCT CODE  
C-DSIU-1D477

PART NO.: N/A

WINDLOAD RATING  
W6 DP37T

DESCRIPTION: 1-3/4" INTELLICORE DOORS UP TO 16'2"W (SEE TABLE)	DRAWN BY: SH	DATE: 1/10/13	SCALE: NTS	DWG. SIZE B
CHECKED BY: SH	DATE: 1/10/13	SHEET 1 OF 4	VER: TDI	
DWG. NO.: 104801 - A/B				

DESIGN ENGINEER:  
MARK WESTERFIELD, P.E.  
FLORIDA P.E. #48495, NC P.E. #23832, TEXAS P.E. #91513

CLOPAY / IDEAL / HOLMES				
3717 / C7X17 / --	/ 27GA	1.75"	THICK	MINOR RIB
3718 / C7X18 / --	/ 27GA	1.75"	THICK	FLUSH
3720 / C7X20 / 240U	/ 27GA	2"	THICK	MINOR RIB
3722 / COX22 / --	/ 20GA	2"	THICK	FLUSH
3724 / C7X24 / 244U	/ 24GA	2"	THICK	MINOR RIB
3730 / -- / --	/ 27GA	3"	THICK	MINOR RIB

SHEET:  
2 OF 4

REVISIONS					
REV. NO.	ZONE	DATE	ECN NO.	APPVD:	DESCRIPTION
04	-	-	-	-	SEE REVISION HISTORY ON SHEET ONE.

**IMPACT-RESISTANT CONSTRUCTION:**  
 SOLID DOORS (NO GLAZING) OR DOORS WITH OPTIONAL IMPACT-RESISTANT GLAZING ARE IMPACT-RESISTANT. OPTIONAL IMPACT RESISTANT ASSEMBLY CONSISTS OF ALUMINUM FRONT FRAME AND SABIC IP LEXAN 9034 (VERSIONS ALSO APPROVED: MR10, 9030, 90318, 90316, 90317, 90311, 90314, 90355) OR BAYER MAKROLON GP (VERSIONS ALSO APPROVED: SL, 90, 15), APPROVED CC1 PLASTICS IN ACCORDANCE WITH IBC/FBC 2606 AND APPROVED C PLASTICS IN ACCORDANCE WITH FBC 2612. THE ENTIRE DOOR ASSEMBLY INSTALLED IN COMPLIANCE WITH THIS SECTION MEETS THE WIND LOAD REQUIREMENTS OF THE FLORIDA BUILDING CODE AND INTERNATIONAL BUILDING CODE AND IS LARGE- AND SMALL-MISSILE IMPACT RESISTANT.

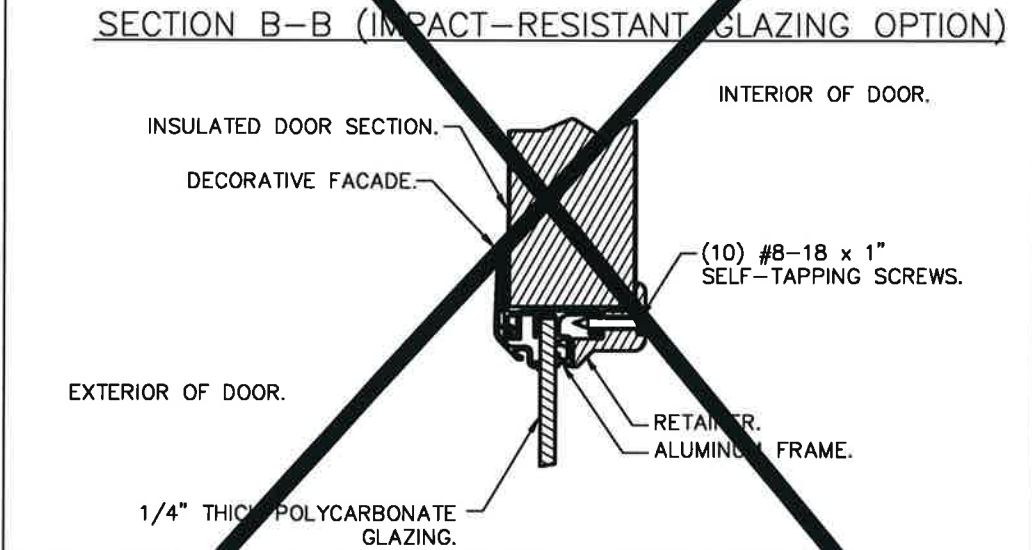

**IMPACT-RESISTANT ASSEMBLY DETAILS  
DRAWING 104801-A**

**STANDARD ASSEMBLY CONSTRUCTION:**  
 OPTIONAL LITES WITH SINGLE PANE OR INSULATED GLAZING AVAILABLE. ALL PANES 1/8" MIN. ANNEALED GLASS OR STRONGER. INSULATED GLAZING CONSISTS OF (2) PANES 1/8" THICK.  
 THE ENTIRE DOOR ASSEMBLY INSTALLED IN COMPLIANCE WITH THIS SECTION MEETS THE WIND LOAD REQUIREMENTS OF THE FLORIDA BUILDING CODE OR INTERNATIONAL BUILDING CODE BUT DOES NOT MEET THE IMPACT RESISTANT REQUIREMENT FOR WINDBORNE DEBRIS REGIONS (REF. CHAPTER 16 FBC/IBC).

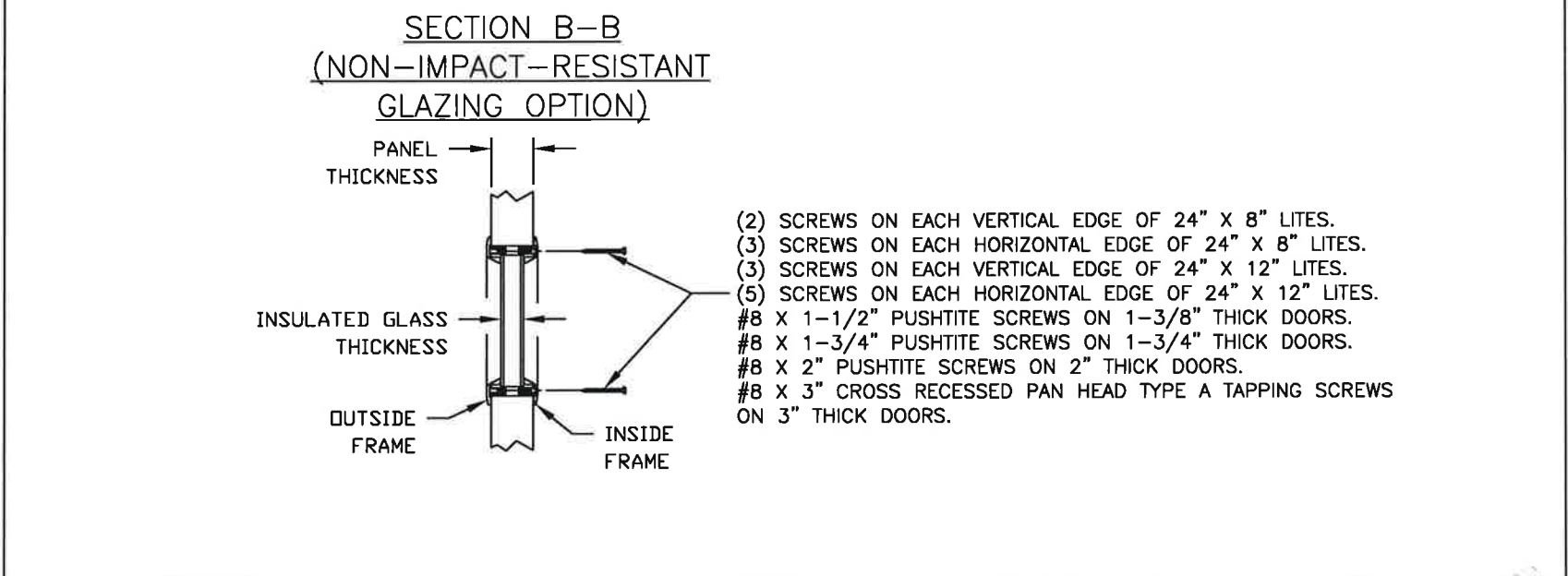

**STANDARD ASSEMBLY DETAILS  
DRAWING 104801-B**

DESIGN ENGINEER:  
 MARK WESTERFIELD, P.E.  
 FLORIDA P.E. #48495, NC P.E. #23832, TEXAS P.E. #91513

DESIGN LOADS: +37.0 P.S.F. & -42.0 P.S.F.  
 TEST LOADS: +55.5 P.S.F. & -63.0 P.S.F.

Unless Stated Otherwise  
 TOLERANCES are  
 .0 = ±.031  
 .00 = ±.015  
 .000 = ±.005  
 .0000 = ±.001  
 Degrees = ±1/2"  
 Unless Stated Otherwise  
 DIMENSIONS ARE IN INCHES.

**Glopay CORPORATION**  
 8585 Duke Boulevard  
 Mason, OH 45040 USA  
 Tel. No. 513-770-4800  
 Fax No. 513-770-4853

*Mark Westerfield*  
 5/31/22

MANUFACTURING PRODUCT CODE C-DSIU-1D477	
PART NO.: N/A	
WINDLOAD RATING W6 DP37T	
DESCRIPTION: 1-3/4" INTELLICORE DOORS UP TO 16'2"W (SEE TABLE)	
DRAWN BY: SH	DATE: 1/10/13
CHECKED BY: SH	DATE: 1/10/13
DWG. NO.: 104801 - A/B	VER: TDI





CLOPAY / IDEAL / HOLMES			
3717 / C7X17 / --	/ 27GA 1.75" THICK MINOR RIB		
3718 / C7X18 / --	/ 27GA 1.75" THICK FLUSH		
3720 / C7X20 / 240U	/ 27GA 2" THICK MINOR RIB		
3722 / COX22 / --	/ 20GA 2" THICK FLUSH		
3724 / C7X24 / 244U	/ 24GA 2" THICK MINOR RIB		

SHEET:  
3 OF 4

REVISIONS					DESCRIPTION
REV. NO.	ZONE	DATE	ECN NO.	APPVD:	
03	-	-	-	-	SEE REVISION HISTORY ON SHEET ONE.

### JAMB TO SUPPORTING STRUCTURE ATTACHMENT

**NOTES:**

1. ALL THE LOAD FROM THE DOOR IS TRANSFERRED TO THE TRACK AND THEN FROM THE TRACK TO THE 2x6 VERTICAL SYP (GRADE #2 OR BETTER) JAMBS. NO LOAD FROM THE DOOR IS TRANSFERRED TO THE HORIZONTAL (TOP) JAMB.
2. EACH VERTICAL JAMB SEES A MAXIMUM DESIGN LOAD OF +296 LB & -336 LB. PER LINEAR FOOT OF JAMB.
3. ALL JAMB FASTENERS MAY BE (BUT ARE NOT REQUIRED TO BE) COUNTERSUNK TO PROVIDE A FLUSH MOUNTING SURFACE.
4. A 1/3 STRESS INCREASE FOR WIND LOAD WAS NOT USED IN THE CALCULATION OF ALLOWABLE LOADS FOR ANCHORS AND FASTENERS FOR STEEL, CONCRETE AND MASONRY.

**NOTE:** 2x6 WOOD JAMBS ARE NOT REQUIRED WITH CONTINUOUS ANGLE MOUNT TRACK. HOWEVER, IF DESIRED ON STEEL JAMBS OR CONCRETE OR BLOCK WALLS, APPROVED FASTENERS AS DETAILED BELOW SHOULD BE INCREASED IN LENGTH BY 1-1/2" AND INSTALLED DIRECTLY THROUGH THE ANGLE AND 2x6 WOOD JAMBS INTO THE STEEL JAMBS OR CONCRETE OR BLOCK WALLS. ANCHORS CAN BE (BUT ARE NOT REQUIRED TO BE) COUNTERSUNK TO PROVIDE A FLUSH MOUNTING SURFACE. CONTINUOUS ANGLE TRACK CAN BE ANCHORED DIRECTLY TO GROUT REINFORCED BLOCK WALL OR 3,000 PSI MIN. CONCRETE COLUMN OR STEEL JAMBS.

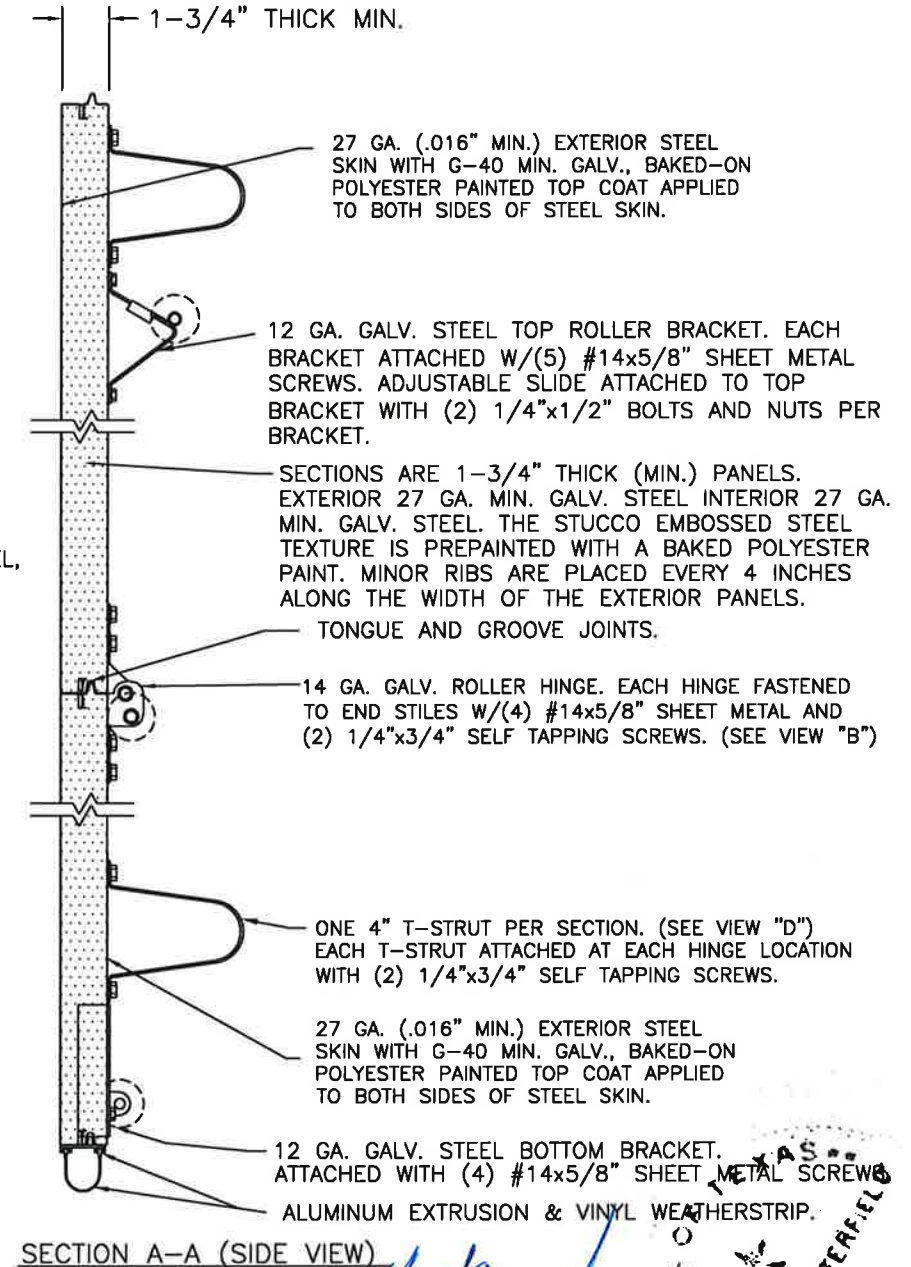
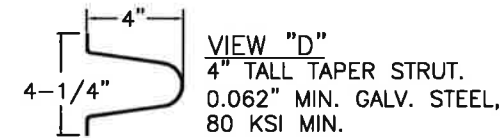
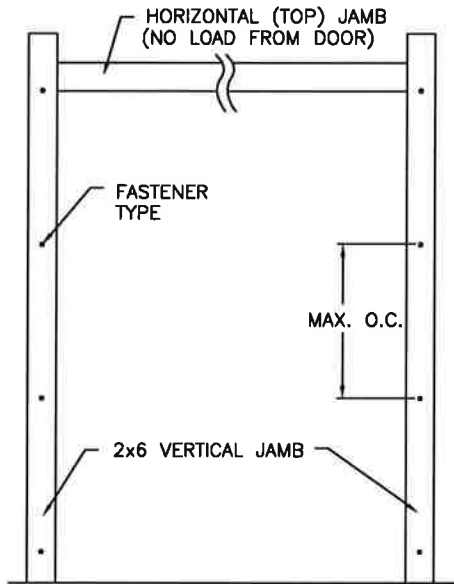

### FASTENER ATTACHMENT TO SUPPORTING STRUCTURE SCHEDULES

BUILDING TYPE	FASTENER TYPE	MAXIMUM ON-CENTER DISTANCE BETWEEN FASTENERS*	STEEL WASHERS REQUIRED?
HOLLOW BLOCK WALL	1/4" x 1-1/4" MIN. EMBED ULTRACON CONCRETE ANCHOR	5-1/2"	1" O.D.
GROUT FILLED BLOCK WALL	1/4" x 1-3/4" MIN. EMBED ULTRACON CONCRETE ANCHOR	9-1/4"	1" O.D.
2000 PSI MIN. CONCRETE	1/4" x 1" MIN. EMBED ULTRACON CONCRETE ANCHOR	8"	1" O.D.
2000 PSI MIN. CONCRETE	1/4" x 1" MIN. EMBED TAPCON CONCRETE ANCHOR	6-3/4"	1" O.D.
2000 PSI MIN. CONCRETE	3/8" x 1-3/4" MIN. EMBED WEJ-IT ANKR TITE SLEEVE ANCHOR	17"	INCLUDED
4000 PSI MIN. CONCRETE	3/8" x 1-3/4" MIN. EMBED WEJ-IT ANKR TITE SLEEVE ANCHOR	24"	INCLUDED
WOOD FRAME (SYP 0.55 SG)	1/2" x 3" LAG SCREW (ASTM A307, GRADE A) 1-5/8" EMBED INTO STRUCTURE	18-1/4"	1" O.D.
14GA STEEL (0.060" MIN.)	1/4"-14 x 1" ITW BUILDEX TEKS SELF-DRILLING FASTENER	7-3/4"	1" O.D.
12GA STEEL (0.105" MIN.)	1/4"-14 x 1" ITW BUILDEX TEKS SELF-DRILLING FASTENER	13-1/2"	1" O.D.
1/8" STEEL	1/4"-14 x 1" ITW BUILDEX TEKS SELF-DRILLING FASTENER	16"	1" O.D.

\* FIRST (BOTTOM) ANCHOR STARTING AT NO MORE THAN HALF OF THE MAXIMUM ON-CENTER DISTANCE. HIGHEST ANCHOR INSTALLED AT LEAST AS HIGH AS THE DOOR OPENING.  
CLOPAY DOES NOT SUPPLY JAMB ATTACHMENT FASTENERS.  
MINIMUM DISTANCE BETWEEN CENTER OF ANCHOR AND EDGE OF CONCRETE BLOCK: 2-1/2", EXCLUDING STUCCO THICKNESS.

DESIGN LOADS: +37.0 P.S.F. & -42.0 P.S.F.  
TEST LOADS: +55.5 P.S.F. & -63.0 P.S.F.

Unless Stated Otherwise  
TOLERANCES are  
.0 = ±.031  
.00 = ±.015  
.000 = ±.005  
.0000 = ±.001  
Degrees = ±1/2°

Unless Stated Otherwise  
DIMENSIONS ARE IN INCHES.

**Glopay** CORPORATION  
8585 Duke Boulevard  
Mason, OH 45040 USA  
Tel. No. 513-770-4800  
Fax No. 513-770-4853

DESCRIPTION: 1-3/4" INTELICORE DOORS UP TO 16'2"W (SEE TABLE)		WINDLOAD RATING
DRAWN BY: SH	DATE: 1/10/13	SCALE: NTS
CHECKED BY: SH	DATE: 1/10/13	DWG. SIZE B
DWG. NO.: 104801 - A/B	VER: TDI	

MANUFACTURING PRODUCT CODE  
C-DSIU-1D477

PART NO.: N/A

DESIGN ENGINEER:  
MARK WESTERFIELD, P.E.  
FLORIDA P.E. #48495, NC P.E. #23832, TEXAS P.E. #91513

*Mark Westerfield*  
5/31/22  
WESTERFIELD  
ENGINEERING

CLOPAY / IDEAL / HOLMES			
3717 / C7X17 / --	/ 27GA 1.75" THICK MINOR RIB		
3718 / C7X18 / --	/ 27GA 1.75" THICK FLUSH		
3720 / C7X20 / 240U	/ 27GA 2" THICK MINOR RIB		
3722 / COX22 / --	/ 20GA 2" THICK FLUSH		
3724 / C7X24 / 244U	/ 24GA 2" THICK MINOR RIB		

SHEET:  
4 OF 4

REVISIONS					DESCRIPTION
REV. NO.	ZONE	DATE	ECN NO.	APPVD.	
03	-	-	-	-	SEE REVISION HISTORY ON SHEET ONE.

**2" TRACK CONFIGURATION**  
DOORS UP TO 800 LBS.

NOTE DOUBLE TRACK HEADROOM, HI-LIFT TRACK, FOLLOW-THE-ROOF TRACK, AND VERTICAL LIFT TRACK ARE AVAILABLE OPTIONS. TRACK CONFIGURATION ABOVE THE DOOR OPENING DOES NOT AFFECT THE WIND LOAD RATING.

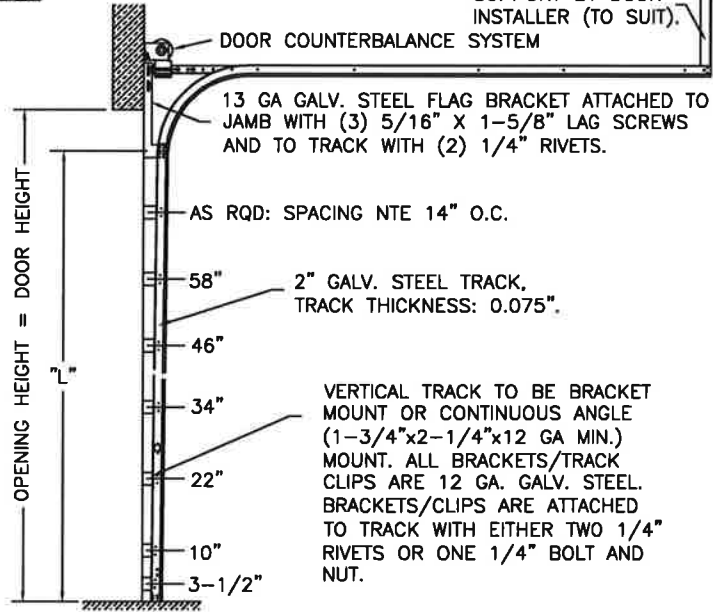

DOOR HEIGHT "L"	"L"
6'-6"	70"
7'-0"	76"
7'-6"	82"
8'-0"	88"
8'-6"	94"
9'-0"	100"
9'-6"	106"
10'-0"	112"
10'-6"	118"
11'-0"	124"
11'-6"	130"
12'-0"	136"
12'-6"	142"
13'-0"	148"
13'-6"	154"
14'-0"	160"
14'-6"	166"
15'-0"	172"
15'-6"	178"
16'-0"	184"
16'-6"	190"
17'-0"	196"
17'-6"	202"
18'-0"	208"

**JAMB CONFIGURATION**  
DOORS UP TO 800 LBS.

**BRACKET MOUNT JAMB CONFIGURATION**

2x6 SYP WOOD JAMB, REQUIRED FOR BRACKET MOUNT.

1" DOOR OVERLAP (EACH SIDE)

2-1/2" X 12 GA GALV. STEEL TRACK BRACKETS FASTENED TO WOOD JAMBS WITH 5/8" X 1-5/8" LAG SCREWS NOT TO EXCEED 14" ON-CENTER.

2" GALV. STEEL TRACK FASTENED TO 12 GA GALV STEEL TRACK BRACKETS WITH EITHER (2) 1/4" DIA. RIVETS OR (1) 1/4" X 5/8" BOLT & NUT PER TRACK BRACKET.

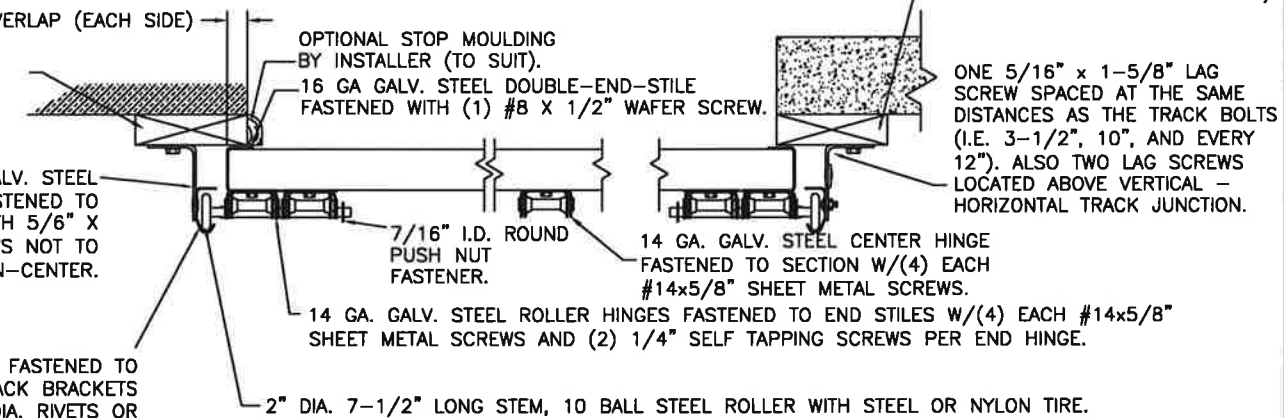

**ANGLE MOUNT JAMB CONFIGURATION**

**3" TRACK CONFIGURATION**  
DOORS 800 LBS AND OVER.

NOTE DOUBLE TRACK HEADROOM, HI-LIFT TRACK, FOLLOW-THE-ROOF TRACK, AND VERTICAL LIFT TRACK ARE AVAILABLE OPTIONS. TRACK CONFIGURATION ABOVE THE DOOR OPENING DOES NOT AFFECT THE WIND LOAD RATING.

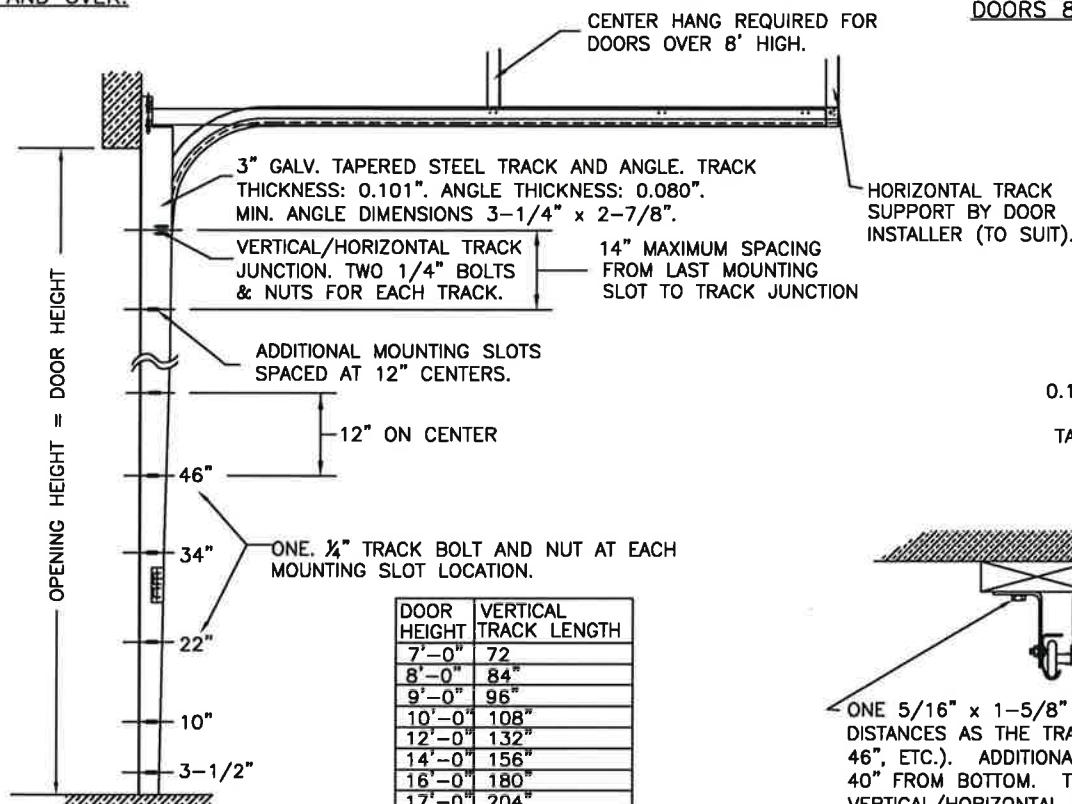

DOOR HEIGHT	VERTICAL TRACK LENGTH
7'-0"	72"
8'-0"	84"
9'-0"	96"
10'-0"	108"
12'-0"	132"
14'-0"	156"
16'-0"	180"
17'-0"	204"
18'-0"	228"

**JAMB CONFIGURATION**  
DOORS 800 LBS AND OVER.

2x6 SYP JAMB (IF PRESENT; SEE JAMB NOTES ON SHEET 3).

OPTIONAL STOP MOULDING BY DOOR INSTALLER (TO SUIT).

16 GA GALV. STEEL DOUBLE-END-STILE FASTENED WITH (1) #8 X 1/2" WAFER SCREW.

3-1/4" X 2-7/8" MIN. X 0.080" TAPERED ANGLE. SEE LAG BOLT MOUNTING AT TRACK CONFIGURATION BELOW.

7/16" I.D. ROUND PUSH NUT FASTENER.

14 GA. GALV. STEEL CENTER HINGE FASTENED TO SECTION W/(4) EACH #14x5/8" SHEET METAL SCREWS.

14 GA. GALV. STEEL ROLLER HINGES FASTENED TO END STILES W/(4) EACH #14x5/8" SHEET METAL SCREWS AND (2) 1/4" SELF TAPPING SCREWS PER END HINGE.

3" DIA. 8-1/2" LONG STEM BALL BEARING STEEL ROLLER.

1" DOOR OVERLAP (EACH SIDE)

0.101" THICK 3" GALV. STEEL TRACK FASTENED TO TAPERED ANGLE. TRACK ATTACHED TO TAPERED ANGLE WITH ONE 1/4"x5/8" BOLT & NUT AT EACH MOUNTING SLOT.

ONE 5/16" X 1-5/8" LAG SCREW SPACED AT THE SAME DISTANCES AS THE TRACK BOLTS (I.E. 3-1/2", 10", 22", 34", 46", ETC.). ADDITIONAL LAG SCREWS LOCATED AT 16", 28", & 40" FROM BOTTOM. TWO LAG SCREWS ALSO LOCATED ABOVE VERTICAL/HORIZONTAL TRACK JUNCTION.

**SECTION C-C**  
PREPARATION OF JAMBS BY OTHERS.

LHR BRACKET (2-1/2" X 5-3/4" X 12GA) ATTACHED WITH (2) 1/4" X 3/4" SELF TAPPING SCREWS. NOTE THAT LHR BRACKETS ARE ALSO USED WITH "DOUBLE END STILE" AS SHOWN IN ZONE B-3 SHEET 1.

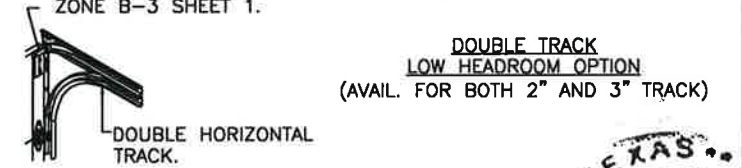

**SECTION C-C**  
PREPARATION OF JAMBS BY OTHERS.

DESIGN LOADS: +37.0 P.S.F. & -42.0 P.S.F.  
TEST LOADS: +55.5 P.S.F. & -63.0 P.S.F.

Unless Stated Otherwise TOLERANCES are

.0 = ±.031  
.00 = ±.015  
.000 = ±.005  
.0000 = ±.001  
Degrees = ±1/2"

Unless Stated Otherwise DIMENSIONS ARE IN INCHES.

**Glopay CORPORATION**  
8585 Duke Boulevard  
Mason, OH 45040 USA  
Tel. No. 513-770-4800  
Fax No. 513-770-4853

DESCRIPTION: 1-3/4" INTELLICORE DOORS UP TO 16'2"W (SEE TABLE)

DRAWN BY: SH	DATE: 1/10/13	SCALE: NTS	DWG. SIZE B
CHECKED BY: SH	DATE: 1/10/13	SHEET 4 OF 4	
DWG. NO.: 104801 - A/B	VER: TDI		

DESIGN ENGINEER:  
MARK WESTERFIELD, P.E.  
FLORIDA P.E. #48495, NC P.E. #23832, TEXAS P.E. #91513

