

NOTE: DOUBLE TRACK LOW HEADROOM, HI-LIFT TRACK, FOLLOW-THE-ROOF TRACK, AND VERTICAL LIFT TRACK ARE AVAILABLE OPTIONS. 3" TRACK ALSO AVAILABLE.

MAX 16'-2" WIDE X 18'-0" HIGH

MODELS AVAILABLE (CLOPAY/ HOLMES/ IDEAL)
 MODELS 524, 520/ 224/ C4ST, C0ST
 INSULATED MODELS 524S, 520S, 524V/ 224S/ C4SS, C0SS, C4SV

HORIZONTAL TRACK END HANGER BRACKET (SUPPLIED BY DOOR INSTALLER) CLOSES ROLLER CHANNEL. INTERMEDIATE HANGER REQUIRED FOR DOORS IF HORIZONTAL TRACK DEFLECTION EXCEEDS 1/240TH OF THE DOOR HEIGHT

THIS PRODUCT COMPLIES WITH THE 2018 IBC/IRC.

CAST ALUMINUM CABLE DRUM



GALV STEEL TRACK SECTIONS - HORIZONTAL - 14 GA MIN.

GALVANIZED STEEL TRACK SECTIONS VERTICAL - .060 MIN

VERTICAL TRACK TO BE CONTINUOUS ANGLE OR REVERSE ANGLE TRACK. TRACK CLIPS ARE 12 GA. GALV. STEEL. CLIPS ARE ATTACHED TO TRACK WITH EITHER TWO 1/4" RIVETS OR ONE 1/4" BOLT.

DOOR WIDTH	NUMBER OF CENTER STILES	NUMBER OF C-CHANNEL STRAPS
12'-3" THRU 13'-2"	2	4
13'-3" THRU 16'-2"	3	5

DOOR HEIGHT 'A'	NUMBER OF SECTIONS
UP TO 8'-0"	4
8'-3" THRU 10'-0"	5
10'-3" THRU 12'-0"	6
12'-3" THRU 14'-0"	7
14'-3" THRU 16'-0"	8
16'-3" THRU 18'-0"	9

MAX. SECTION HEIGHT: 24"

STANDARD-LIFT TRACK DETAILS

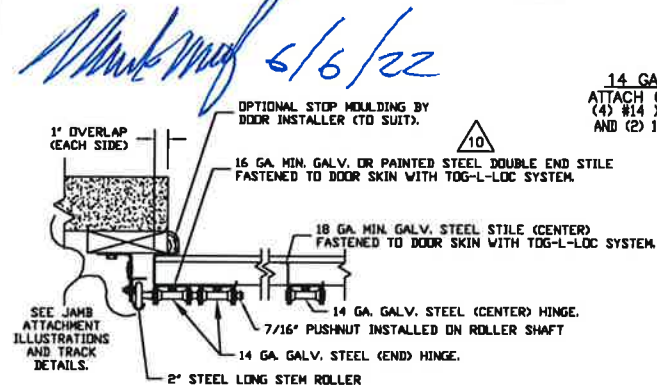

SECTION 2-2

WOOD JAMB ON CONCRETE

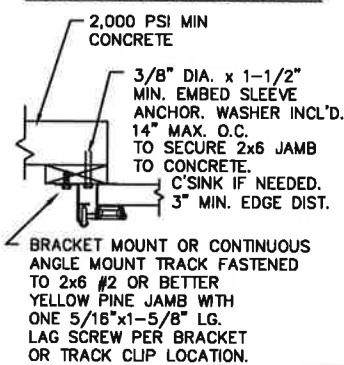

CONCRETE JAMBS

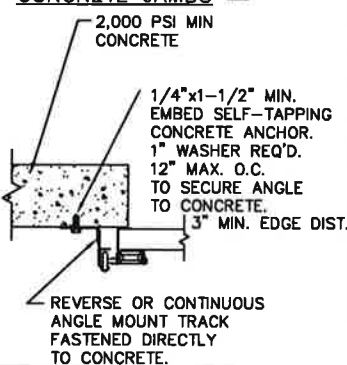

WELDED STEEL JAMBS

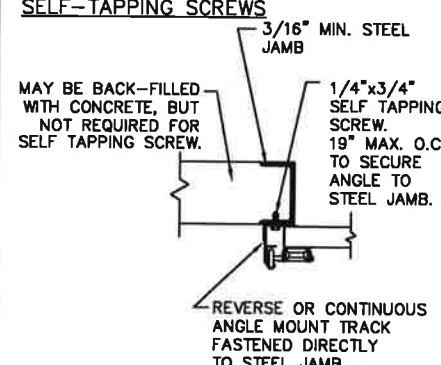

WOOD JAMBS

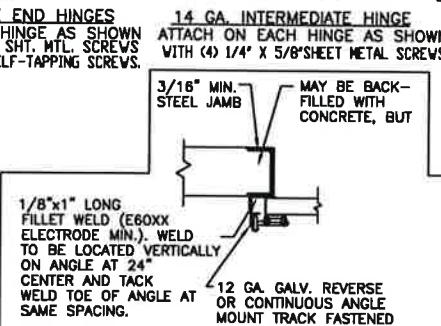
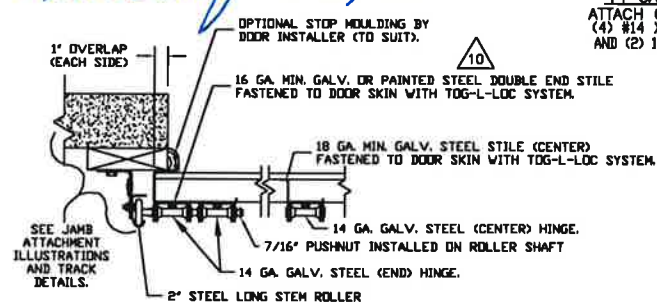
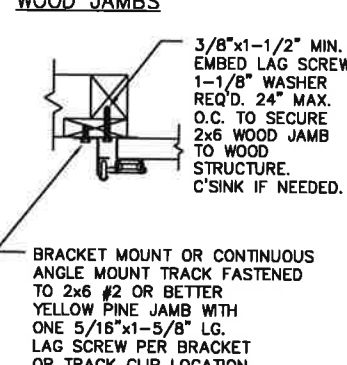

OPTIONAL ALUMINUM FULL VISION WINDOW LITE SECTIONS AVAILABLE. SINGLE PANE OR INSULATED. ALL PANES ANNEALED GLASS OR STRONGER. SINGLE PANES 1/4" OR THICKER. INSULATED WINDOWS 1/2" THICK, CONSISTING OF (2) PANES 1/4" THICK. FULL VISION SECTIONS TO HAVE 2" X 2" X 1/8" L-ANGLE HORIZONTAL REINFORCEMENT, ATTACHED TO THE REINFORCING RIB WITH 4" X 6" OFFSET PLATES AT EVERY HINGE LOCATION AND THE CENTER OF EACH PANEL WITH (2) 1/4"-20 X 5/8" HEX HEAD BOLTS AND NUTS. MAXIMUM BACK CHANNEL - ONE C-CHANNEL PER SECTION. SEE SECTION 1-1 FOR MOUNTING DETAILS.

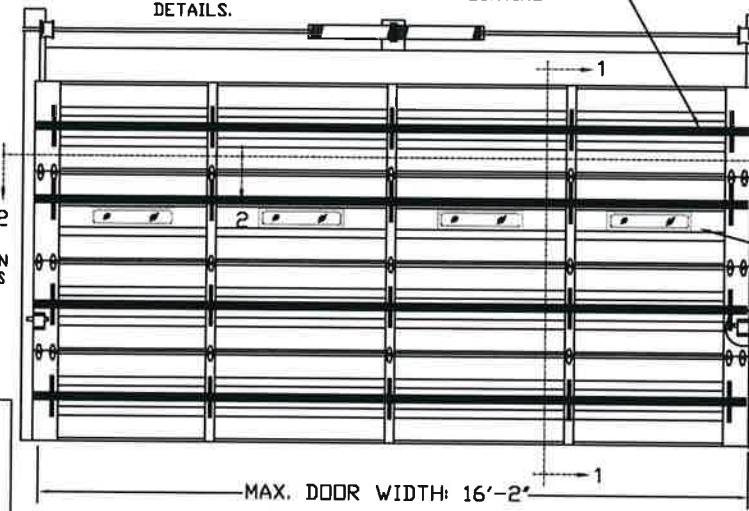

ANCHOR NOTE: FIRST (BOTTOM) ANCHOR STARTING AT NO MORE THAN HALF OF THE MAXIMUM ON-CENTER DISTANCE. HIGHEST ANCHOR INSTALLED AT LEAST AS HIGH AS THE DOOR OPENING.

THE OPTIONAL GLAZING SHOWN ON THIS DRAWING MEETS THE WIND LOAD REQUIREMENTS OF THE FLORIDA BUILDING CODE OR INTERNATIONAL BUILDING CODE BUT DOES NOT MEET THE IMPACT RESISTANT REQUIREMENT FOR WINDBORNE DEBRIS REGIONS (REF. CHAPTER 16 FBC/IBC)

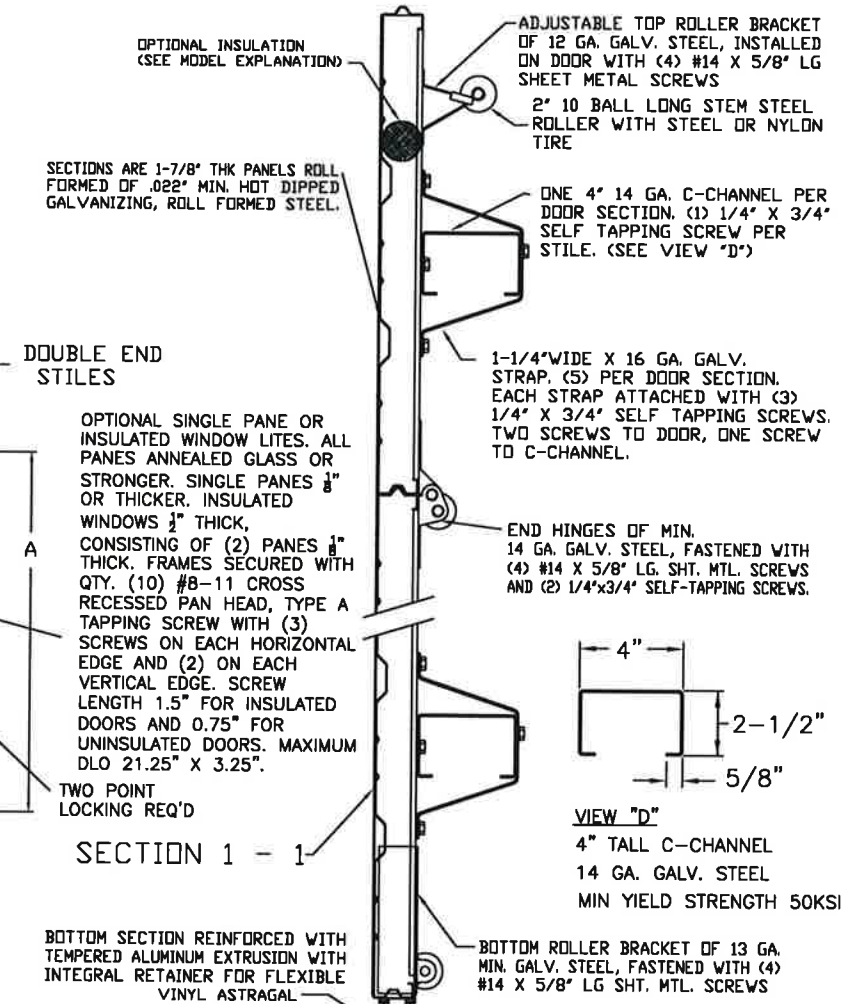

DOUBLE END STILES

OPTIONAL SINGLE PANE OR INSULATED WINDOW LITES. ALL PANES ANNEALED GLASS OR STRONGER. SINGLE PANES 1/4" OR THICKER. INSULATED WINDOWS 1/2" THICK, CONSISTING OF (2) PANES 1/4" THICK. FRAMES SECURED WITH QTY. (10) #8-11 CROSS RECESSED PAN HEAD, TYPE A TAPPING SCREW WITH (3) SCREWS ON EACH HORIZONTAL EDGE AND (2) ON EACH VERTICAL EDGE. SCREW LENGTH 1.5" FOR INSULATED DOORS AND 0.75" FOR UNINSULATED DOORS. MAXIMUM DLO 21.25" X 3.25".

TWO POINT LOCKING REQ'D

SECTION 1 - 1

BOTTOM SECTION REINFORCED WITH TEMPERED ALUMINUM EXTRUSION WITH INTEGRAL RETAINER FOR FLEXIBLE VINYL ASTRAGAL

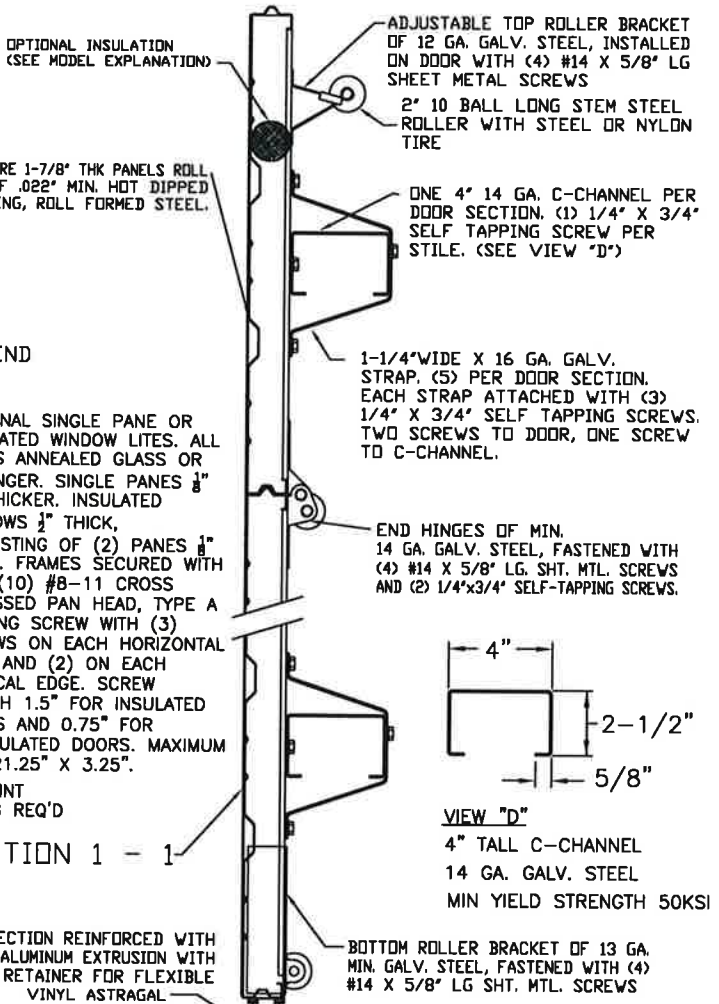

OPTIONAL INSULATION (SEE MODEL EXPLANATION)

SECTIONS ARE 1-7/8" THK PANELS ROLL FORMED OF .022" MIN. HOT DIPPED GALVANIZING, ROLL FORMED STEEL.

DOUBLE END STILES

OPTIONAL SINGLE PANE OR INSULATED WINDOW LITES. ALL PANES ANNEALED GLASS OR STRONGER. SINGLE PANES 1/4" OR THICKER. INSULATED WINDOWS 1/2" THICK, CONSISTING OF (2) PANES 1/4" THICK. FRAMES SECURED WITH QTY. (10) #8-11 CROSS RECESSED PAN HEAD, TYPE A TAPPING SCREW WITH (3) SCREWS ON EACH HORIZONTAL EDGE AND (2) ON EACH VERTICAL EDGE. SCREW LENGTH 1.5" FOR INSULATED DOORS AND 0.75" FOR UNINSULATED DOORS. MAXIMUM DLO 21.25" X 3.25".

TWO POINT LOCKING REQ'D

SECTION 1 - 1

BOTTOM SECTION REINFORCED WITH TEMPERED ALUMINUM EXTRUSION WITH INTEGRAL RETAINER FOR FLEXIBLE VINYL ASTRAGAL

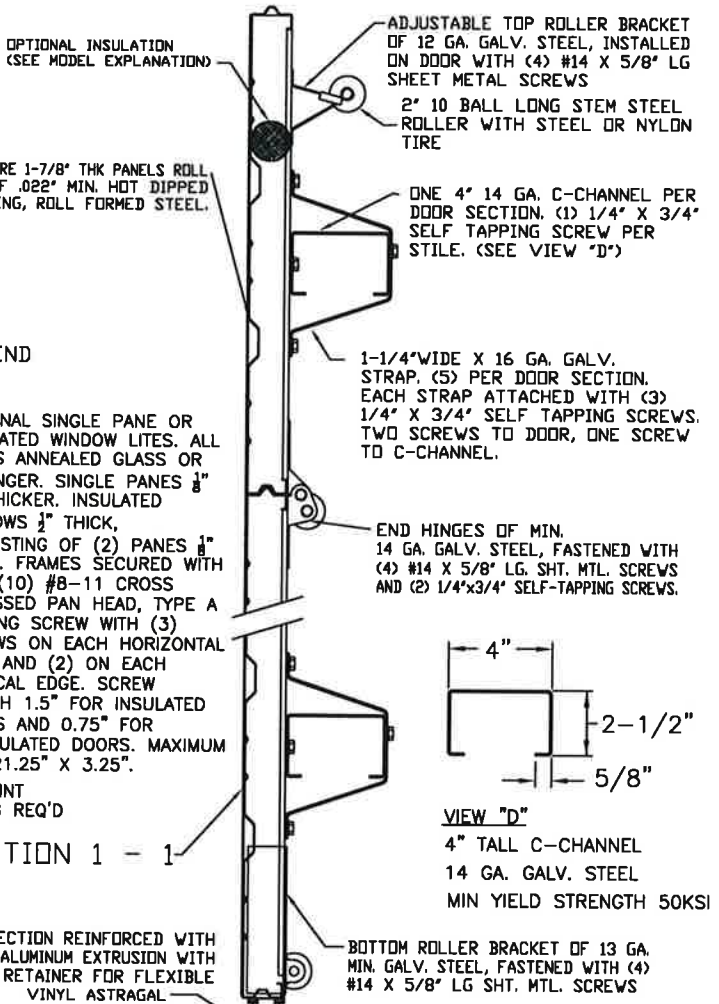

OPTIONAL INSULATION (SEE MODEL EXPLANATION)

SECTIONS ARE 1-7/8" THK PANELS ROLL FORMED OF .022" MIN. HOT DIPPED GALVANIZING, ROLL FORMED STEEL.

DOUBLE END STILES

OPTIONAL SINGLE PANE OR INSULATED WINDOW LITES. ALL PANES ANNEALED GLASS OR STRONGER. SINGLE PANES 1/4" OR THICKER. INSULATED WINDOWS 1/2" THICK, CONSISTING OF (2) PANES 1/4" THICK. FRAMES SECURED WITH QTY. (10) #8-11 CROSS RECESSED PAN HEAD, TYPE A TAPPING SCREW WITH (3) SCREWS ON EACH HORIZONTAL EDGE AND (2) ON EACH VERTICAL EDGE. SCREW LENGTH 1.5" FOR INSULATED DOORS AND 0.75" FOR UNINSULATED DOORS. MAXIMUM DLO 21.25" X 3.25".

TWO POINT LOCKING REQ'D

SECTION 1 - 1

BOTTOM SECTION REINFORCED WITH TEMPERED ALUMINUM EXTRUSION WITH INTEGRAL RETAINER FOR FLEXIBLE VINYL ASTRAGAL

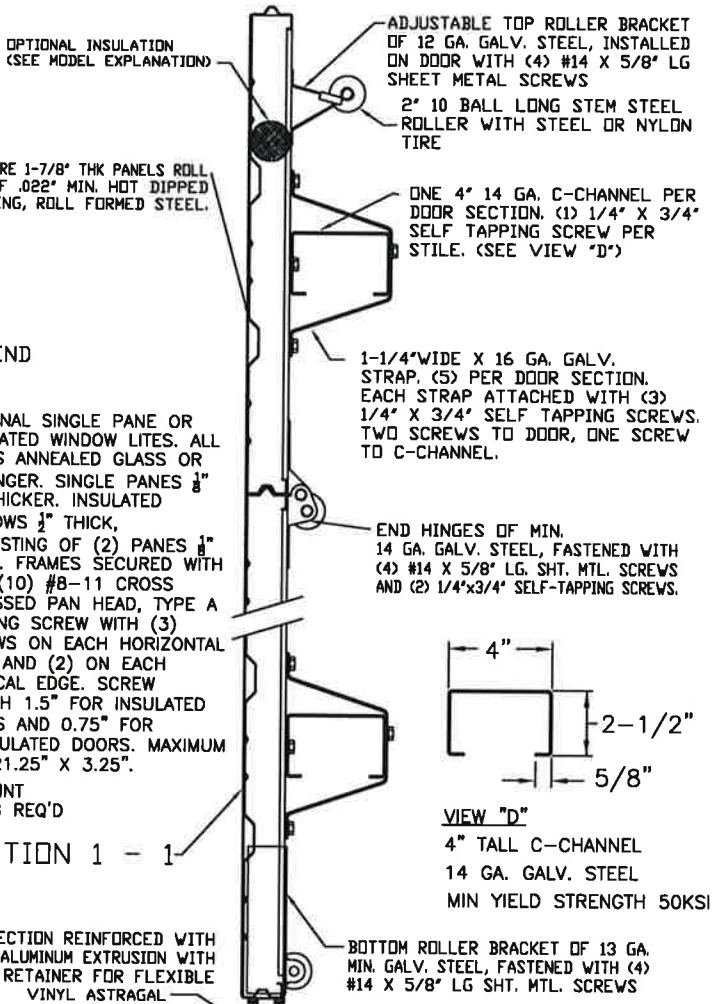

OPTIONAL INSULATION (SEE MODEL EXPLANATION)

SECTIONS ARE 1-7/8" THK PANELS ROLL FORMED OF .022" MIN. HOT DIPPED GALVANIZING, ROLL FORMED STEEL.

DOUBLE END STILES

OPTIONAL SINGLE PANE OR INSULATED WINDOW LITES. ALL PANES ANNEALED GLASS OR STRONGER. SINGLE PANES 1/4" OR THICKER. INSULATED WINDOWS 1/2" THICK, CONSISTING OF (2) PANES 1/4" THICK. FRAMES SECURED WITH QTY. (10) #8-11 CROSS RECESSED PAN HEAD, TYPE A TAPPING SCREW WITH (3) SCREWS ON EACH HORIZONTAL EDGE AND (2) ON EACH VERTICAL EDGE. SCREW LENGTH 1.5" FOR INSULATED DOORS AND 0.75" FOR UNINSULATED DOORS. MAXIMUM DLO 21.25" X 3.25".

TWO POINT LOCKING REQ'D

SECTION 1 - 1

BOTTOM SECTION REINFORCED WITH TEMPERED ALUMINUM EXTRUSION WITH INTEGRAL RETAINER FOR FLEXIBLE VINYL ASTRAGAL

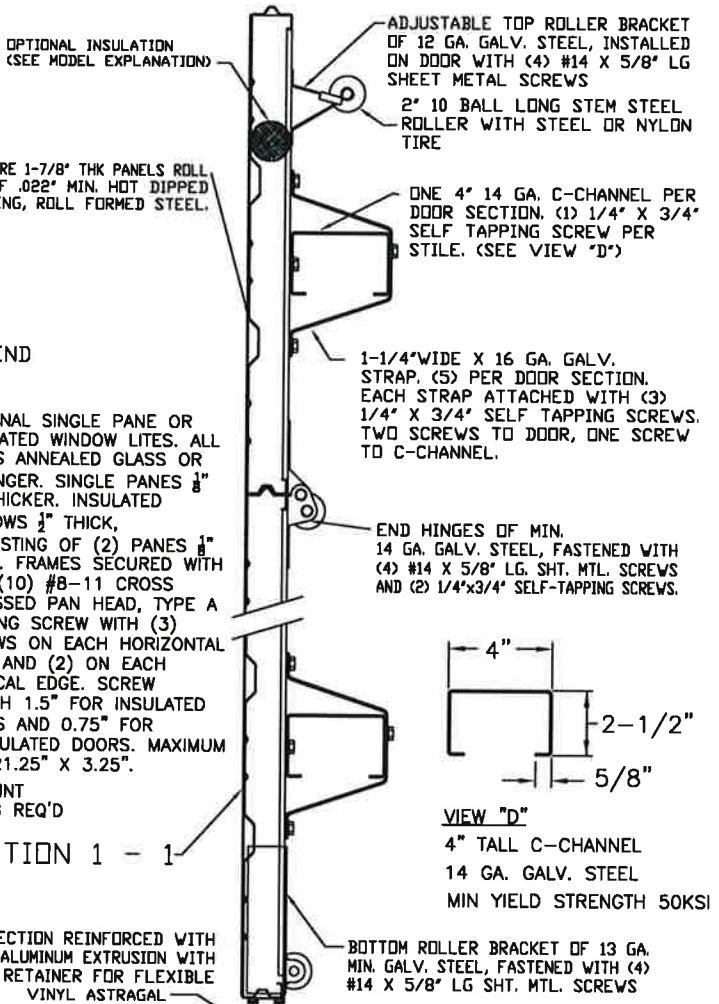

OPTIONAL INSULATION (SEE MODEL EXPLANATION)

SECTIONS ARE 1-7/8" THK PANELS ROLL FORMED OF .022" MIN. HOT DIPPED GALVANIZING, ROLL FORMED STEEL.

DOUBLE END STILES

OPTIONAL SINGLE PANE OR INSULATED WINDOW LITES. ALL PANES ANNEALED GLASS OR STRONGER. SINGLE PANES 1/4" OR THICKER. INSULATED WINDOWS 1/2" THICK, CONSISTING OF (2) PANES 1/4" THICK. FRAMES SECURED WITH QTY. (10) #8-11 CROSS RECESSED PAN HEAD, TYPE A TAPPING SCREW WITH (3) SCREWS ON EACH HORIZONTAL EDGE AND (2) ON EACH VERTICAL EDGE. SCREW LENGTH 1.5" FOR INSULATED DOORS AND 0.75" FOR UNINSULATED DOORS. MAXIMUM DLO 21.25" X 3.25".

TWO POINT LOCKING REQ'D

SECTION 1 - 1

BOTTOM SECTION REINFORCED WITH TEMPERED ALUMINUM EXTRUSION WITH INTEGRAL RETAINER FOR FLEXIBLE VINYL ASTRAGAL

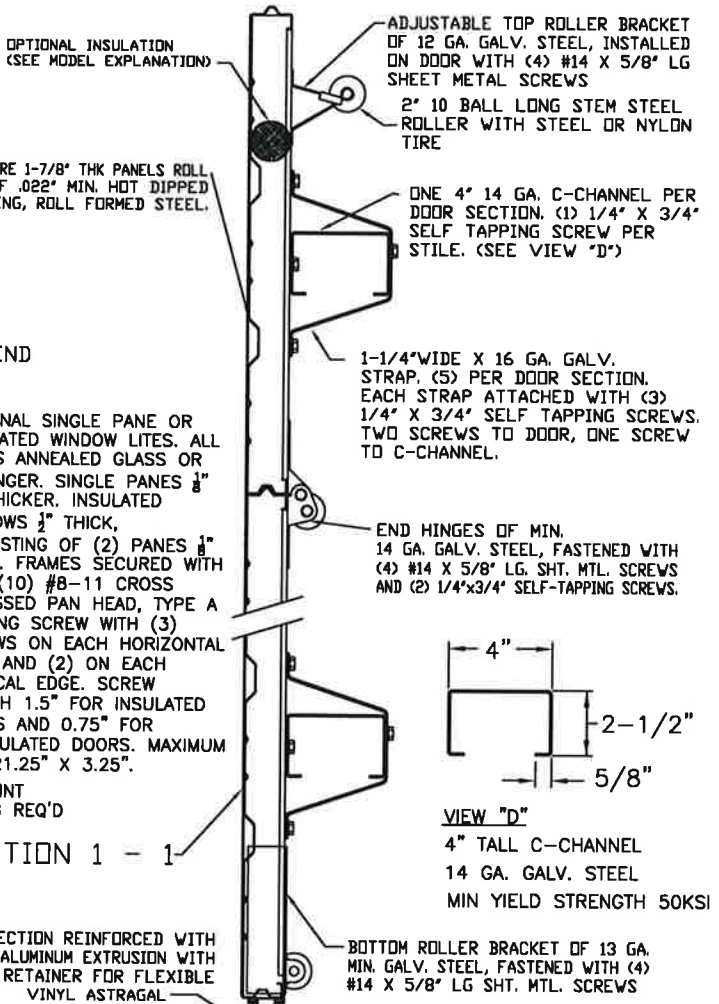

OPTIONAL INSULATION (SEE MODEL EXPLANATION)

SECTIONS ARE 1-7/8" THK PANELS ROLL FORMED OF .022" MIN. HOT DIPPED GALVANIZING, ROLL FORMED STEEL.

DOUBLE END STILES

OPTIONAL SINGLE PANE OR INSULATED WINDOW LITES. ALL PANES ANNEALED GLASS OR STRONGER. SINGLE PANES 1/4" OR THICKER. INSULATED WINDOWS 1/2" THICK, CONSISTING OF (2) PANES 1/4" THICK. FRAMES SECURED WITH QTY. (10) #8-11 CROSS RECESSED PAN HEAD, TYPE A TAPPING SCREW WITH (3) SCREWS ON EACH HORIZONTAL EDGE AND (2) ON EACH VERTICAL EDGE. SCREW LENGTH 1.5" FOR INSULATED DOORS AND 0.75" FOR UNINSULATED DOORS. MAXIMUM DLO 21.25" X 3.25".

TWO POINT LOCKING REQ'D

SECTION 1 - 1

BOTTOM SECTION REINFORCED WITH TEMPERED ALUMINUM EXTRUSION WITH INTEGRAL RETAINER FOR FLEXIBLE VINYL ASTRAGAL

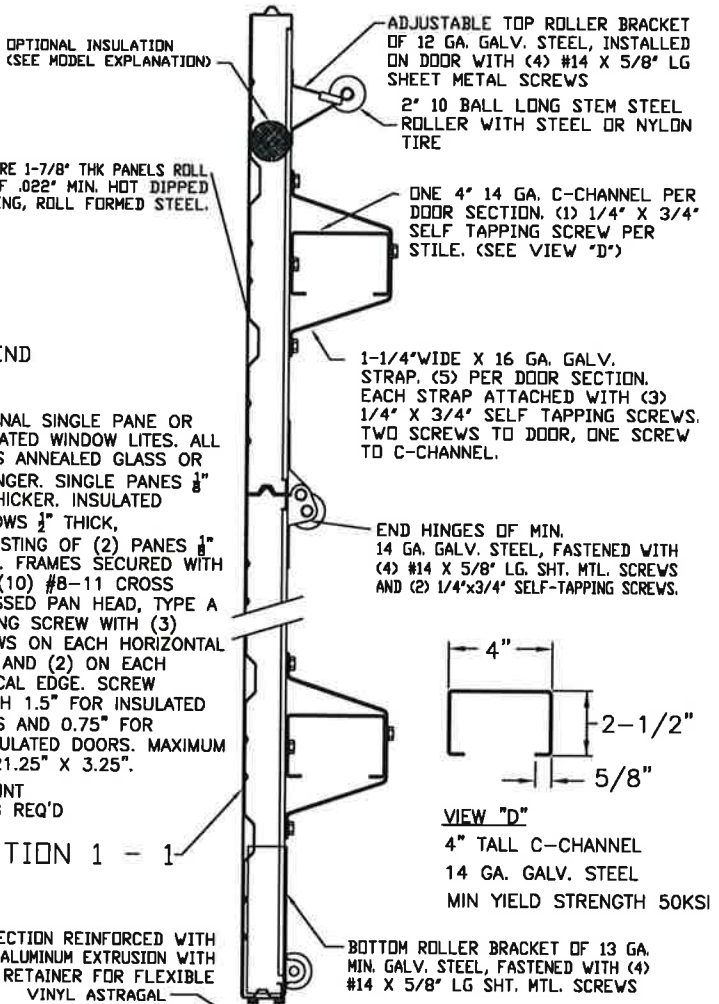

OPTIONAL INSULATION (SEE MODEL EXPLANATION)

SECTIONS ARE 1-7/8" THK PANELS ROLL FORMED OF .022" MIN. HOT DIPPED GALVANIZING, ROLL FORMED STEEL.

DOUBLE END STILES

OPTIONAL SINGLE PANE OR INSULATED WINDOW LITES. ALL PANES ANNEALED GLASS OR STRONGER. SINGLE PANES 1/4" OR THICKER. INSULATED WINDOWS 1/2" THICK, CONSISTING OF (2) PANES 1/4" THICK. FRAMES SECURED WITH QTY. (10) #8-11 CROSS RECESSED PAN HEAD, TYPE A TAPPING SCREW WITH (3) SCREWS ON EACH HORIZONTAL EDGE AND (2) ON EACH VERTICAL EDGE. SCREW LENGTH 1.5" FOR INSULATED DOORS AND 0.75" FOR UNINSULATED DOORS. MAXIMUM DLO 21.25" X 3.25".

TWO POINT LOCKING REQ'D

SECTION 1 - 1

BOTTOM SECTION REINFORCED WITH TEMPERED ALUMINUM EXTRUSION WITH INTEGRAL RETAINER FOR FLEXIBLE VINYL ASTRAGAL

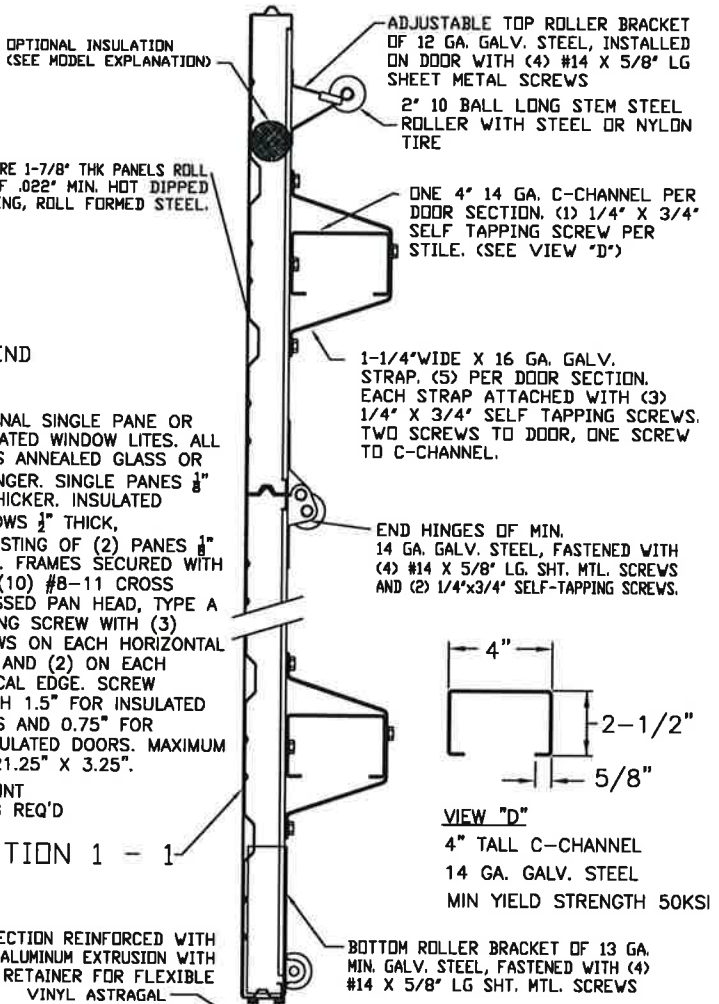

OPTIONAL INSULATION (SEE MODEL EXPLANATION)

SECTIONS ARE 1-7/8" THK PANELS ROLL FORMED OF .022" MIN. HOT DIPPED GALVANIZING, ROLL FORMED STEEL.

DOUBLE END STILES

OPTIONAL SINGLE PANE OR INSULATED WINDOW LITES. ALL PANES ANNEALED GLASS OR STRONGER. SINGLE PANES 1/4" OR THICKER. INSULATED WINDOWS 1/2" THICK, CONSISTING OF (2) PANES 1/4" THICK. FRAMES SECURED WITH QTY. (10) #8-11 CROSS RECESSED PAN HEAD, TYPE A TAPPING SCREW WITH (3) SCREWS ON EACH HORIZONTAL EDGE AND (2) ON EACH VERTICAL EDGE. SCREW LENGTH 1.5" FOR INSULATED DOORS AND 0.75" FOR UNINSULATED DOORS. MAXIMUM DLO 21.25" X 3.25".

TWO POINT LOCKING REQ'D

SECTION 1 - 1

BOTTOM SECTION REINFORCED WITH TEMPERED ALUMINUM EXTRUSION WITH INTEGRAL RETAINER FOR FLEXIBLE VINYL ASTRAGAL

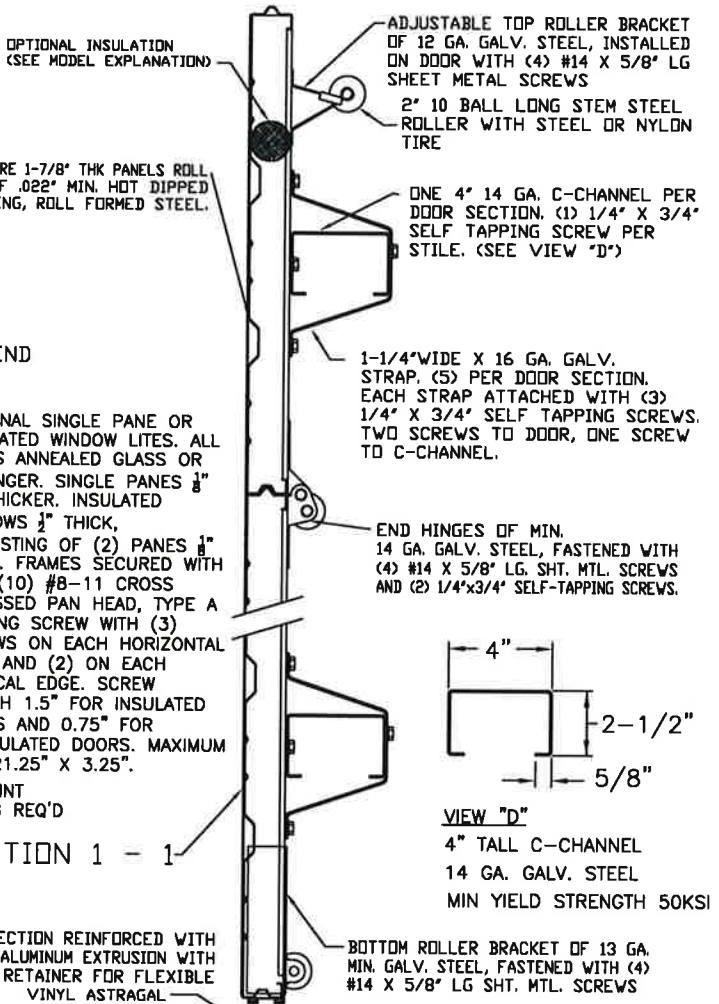

OPTIONAL INSULATION (SEE MODEL EXPLANATION)

SECTIONS ARE 1-7/8" THK PANELS ROLL FORMED OF .022" MIN. HOT DIPPED GALVANIZING, ROLL FORMED STEEL.

DOUBLE END STILES

OPTIONAL SINGLE PANE OR INSULATED WINDOW LITES. ALL PANES ANNEALED GLASS OR STRONGER. SINGLE PANES 1/4" OR THICKER. INSULATED WINDOWS 1/2" THICK, CONSISTING OF (2) PANES 1/4" THICK. FRAMES SECURED WITH QTY. (10) #8-11 CROSS RECESSED PAN HEAD, TYPE A TAPPING SCREW WITH (3) SCREWS ON EACH HORIZONTAL EDGE AND (2) ON EACH VERTICAL EDGE. SCREW LENGTH 1.5" FOR INSULATED DOORS AND 0.75" FOR UNINSULATED DOORS. MAXIMUM DLO 21.25" X 3.25".

TWO POINT LOCKING REQ'D

SECTION 1 - 1

BOTTOM SECTION REINFORCED WITH TEMPERED ALUMINUM EXTRUSION WITH INTEGRAL RETAINER FOR FLEXIBLE VINYL ASTRAGAL

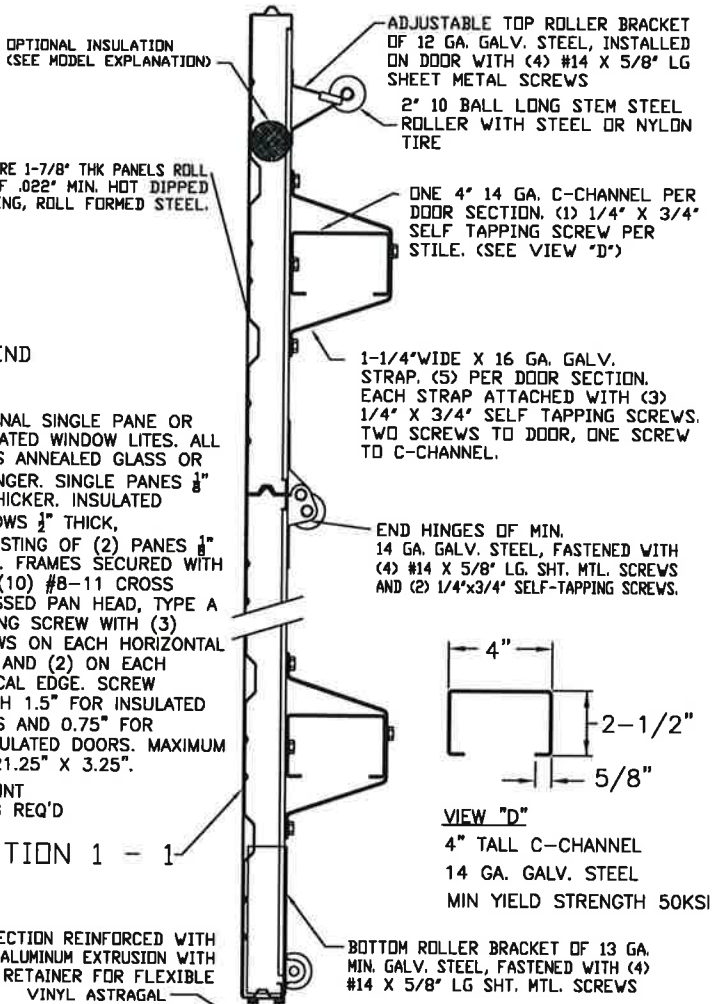

OPTIONAL INSULATION (SEE MODEL EXPLANATION)

SECTIONS ARE 1-7/8" THK PANELS ROLL FORMED OF .022" MIN. HOT DIPPED GALVANIZING, ROLL FORMED STEEL.

DOUBLE END STILES

OPTIONAL SINGLE PANE OR INSULATED WINDOW LITES. ALL PANES ANNEALED GLASS OR STRONGER. SINGLE PANES 1/4" OR THICKER. INSULATED WINDOWS 1/2" THICK, CONSISTING OF (2) PANES 1/4" THICK. FRAMES SECURED WITH QTY. (10) #8-11 CROSS RECESSED PAN HEAD, TYPE A TAPPING SCREW WITH (3) SCREWS ON EACH HORIZONTAL EDGE AND (2) ON EACH VERTICAL EDGE. SCREW LENGTH 1.5" FOR INSULATED DOORS AND 0.75" FOR UNINSULATED DOORS. MAXIMUM DLO 21.25" X 3.25".

TWO POINT LOCKING REQ'D

SECTION 1 - 1

BOTTOM SECTION REINFORCED WITH TEMPERED ALUMINUM EXTRUSION WITH INTEGRAL RETAINER FOR FLEXIBLE VINYL ASTRAGAL

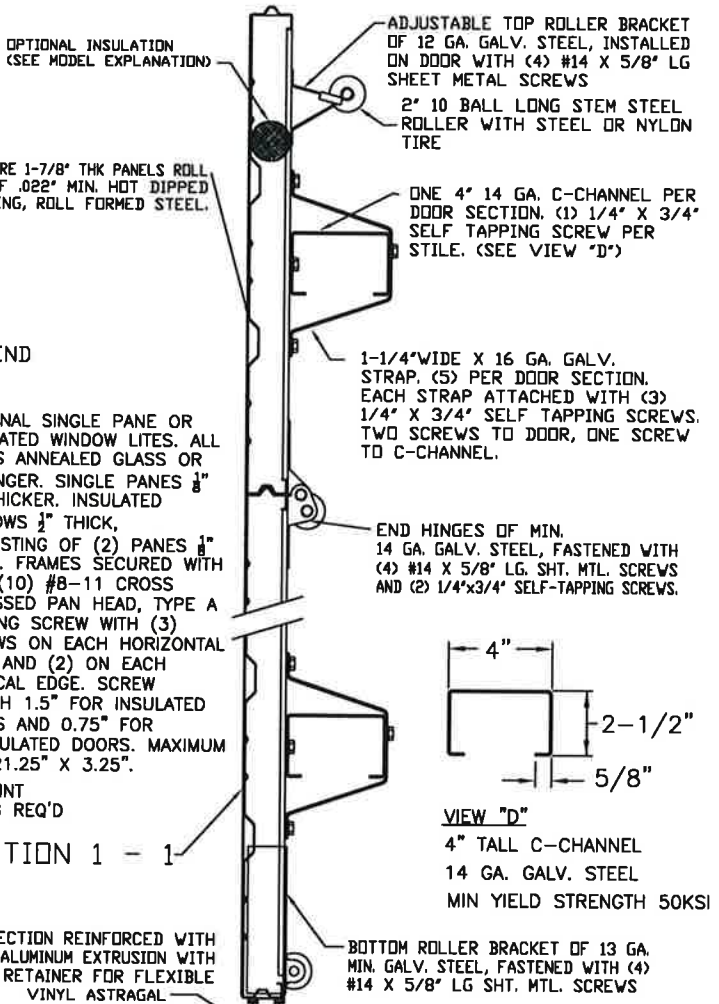

OPTIONAL INSULATION (SEE MODEL EXPLANATION)

SECTIONS ARE 1-7/8" THK PANELS ROLL FORMED OF .022" MIN. HOT DIPPED GALVANIZING, ROLL FORMED STEEL.

DOUBLE END STILES

OPTIONAL SINGLE PANE OR INSULATED WINDOW LITES. ALL PANES ANNEALED GLASS OR STRONGER. SINGLE PANES 1/4" OR THICKER. INSULATED WINDOWS 1/2" THICK, CONSISTING OF (2) PANES 1/4" THICK. FRAMES SECURED WITH QTY. (10) #8-11 CROSS RECESSED PAN HEAD, TYPE A TAPPING SCREW WITH (3) SCREWS ON EACH HORIZONTAL EDGE AND (2) ON EACH VERTICAL EDGE. SCREW LENGTH 1.5" FOR INSULATED DOORS AND 0.75" FOR UNINSULATED DOORS. MAXIMUM DLO 21.25" X 3.25".

TWO POINT LOCKING REQ'D

SECTION 1 - 1

BOTTOM SECTION REINFORCED WITH TEMPERED ALUMINUM EXTRUSION WITH INTEGRAL RETAINER FOR FLEXIBLE VINYL ASTRAGAL

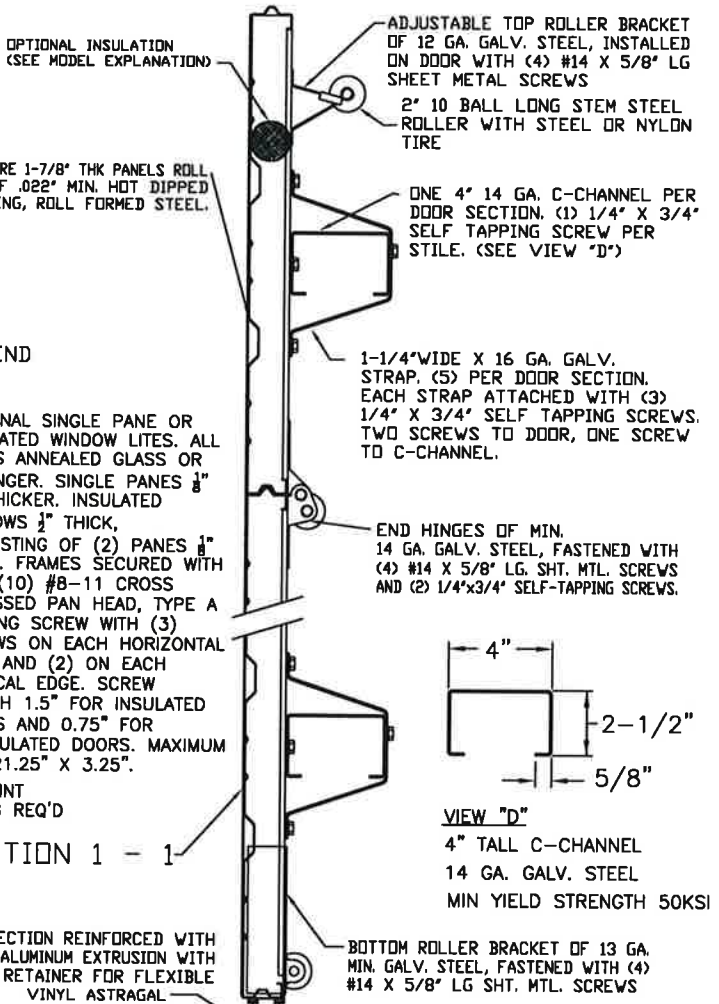

OPTIONAL INSULATION (SEE MODEL EXPLANATION)

SECTIONS ARE 1-7/8" THK PANELS ROLL FORMED OF .022" MIN. HOT DIPPED GALVANIZING, ROLL FORMED STEEL.

DOUBLE END STILES

OPTIONAL SINGLE PANE OR INSULATED WINDOW LITES. ALL PANES ANNEALED GLASS OR STRONGER. SINGLE PANES 1/4" OR THICKER. INSULATED WINDOWS 1/2" THICK, CONSISTING OF (2) PANES 1/4" THICK. FRAMES SECURED WITH QTY. (10) #8-11 CROSS RECESSED PAN HEAD, TYPE A TAPPING SCREW WITH (3) SCREWS ON EACH HORIZONTAL EDGE AND (2) ON EACH VERTICAL EDGE. SCREW LENGTH 1.5" FOR INSULATED DOORS AND 0.75" FOR UNINSULATED DOORS. MAXIMUM DLO 21.25" X 3.25".

TWO POINT LOCKING REQ'D

SECTION 1 - 1

BOTTOM SECTION REINFORCED WITH TEMPERED ALUMINUM EXTRUSION WITH INTEGRAL RETAINER FOR FLEXIBLE VINYL ASTRAGAL

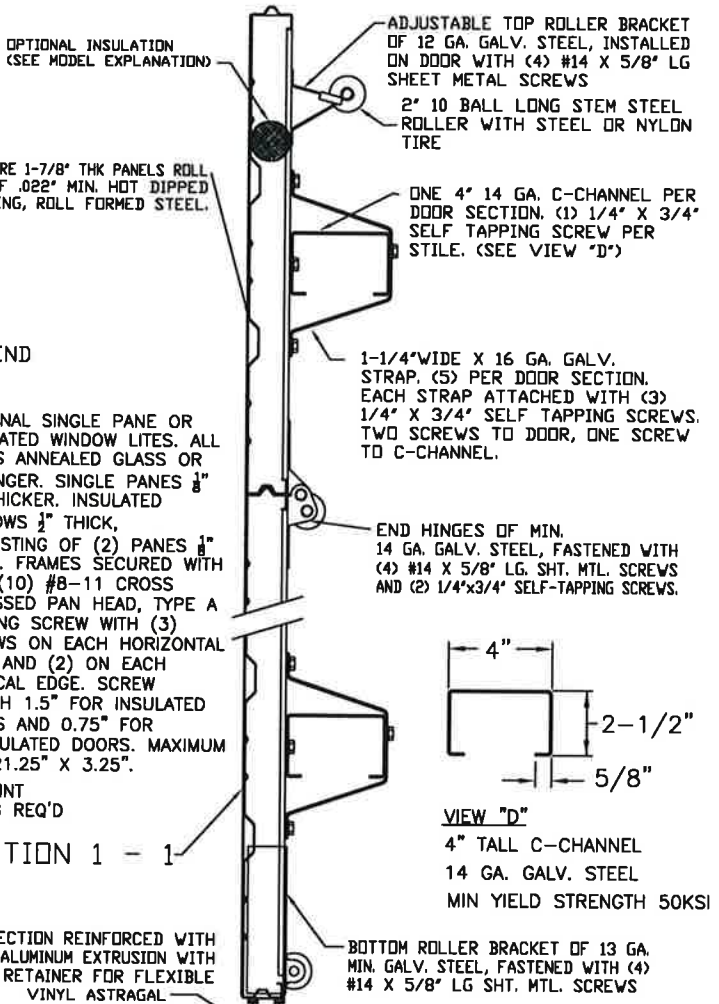

OPTIONAL INSULATION (SEE MODEL EXPLANATION)

SECTIONS ARE 1-7/8" THK PANELS ROLL FORMED OF .022" MIN. HOT DIPPED GALVANIZING, ROLL FORMED STEEL.

DOUBLE END STILES

OPTIONAL SINGLE PANE OR INSULATED WINDOW LITES. ALL PANES ANNEALED GLASS OR STRONGER. SINGLE PANES 1/4" OR THICKER. INSULATED WINDOWS 1/2" THICK, CONSISTING OF (2) PANES 1/4" THICK. FRAMES SECURED WITH QTY. (10) #8-11 CROSS RECESSED PAN HEAD, TYPE A TAPPING SCREW WITH (3) SCREWS ON EACH HORIZONTAL EDGE AND (2) ON EACH VERTICAL EDGE. SCREW LENGTH 1.5" FOR INSULATED DOORS AND 0.75" FOR UNINSULATED DOORS. MAXIMUM DLO 21.25" X 3.25".

TWO POINT LOCKING REQ'D

SECTION 1 - 1

BOTTOM SECTION REINFORCED WITH TEMPERED ALUMINUM EXTRUSION WITH INTEGRAL RETAINER FOR FLEXIBLE VINYL ASTRAGAL

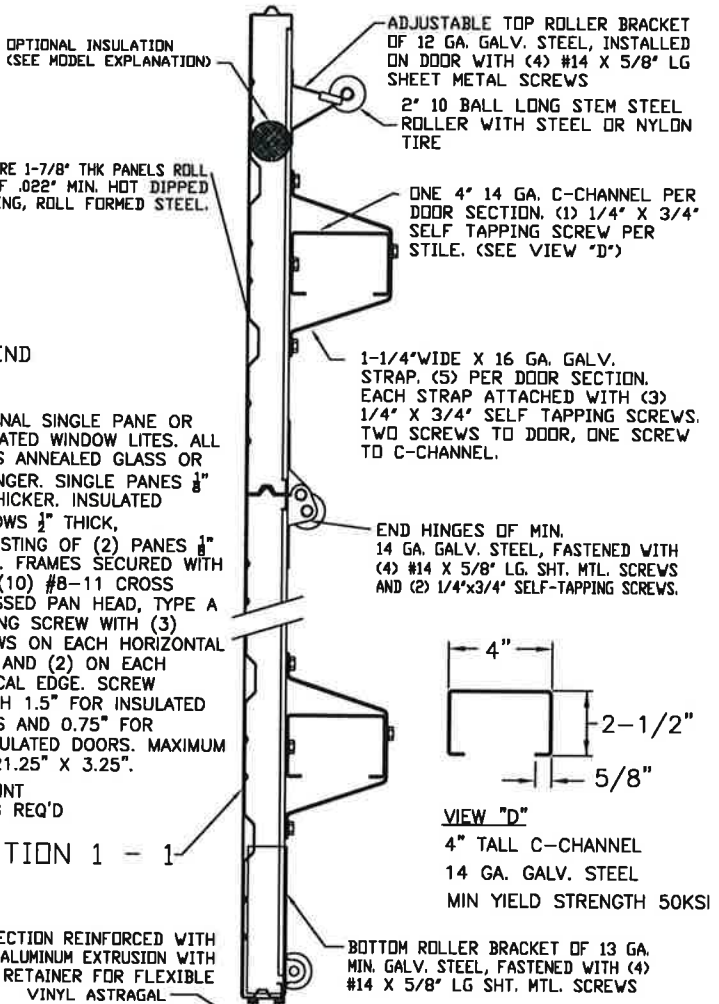

OPTIONAL INSULATION (SEE MODEL EXPLANATION)

SECTIONS ARE 1-7/8" THK PANELS ROLL FORMED OF .022" MIN. HOT DIPPED GALVANIZING, ROLL FORMED STEEL.

DOUBLE END STILES

OPTIONAL SINGLE PANE OR INSULATED WINDOW LITES. ALL PANES ANNEALED GLASS OR STRONGER. SINGLE PANES 1/4" OR THICKER. INSULATED WINDOWS 1/2" THICK, CONSISTING OF (2) PANES 1/4" THICK. FRAMES SECURED WITH QTY. (10) #8-11 CROSS RECESSED PAN HEAD, TYPE A TAPPING SCREW WITH (3) SCREWS ON EACH HORIZONTAL EDGE AND (2) ON EACH VERTICAL EDGE. SCREW LENGTH 1.5" FOR INSULATED DOORS AND 0.75" FOR UNINSULATED DOORS. MAXIMUM DLO 21.25" X 3.25".

TWO POINT LOCKING REQ'D

SECTION 1 - 1

BOTTOM SECTION REINFORCED WITH TEMPERED ALUMINUM EXTRUSION WITH INTEGRAL RETAINER FOR FLEXIBLE VINYL ASTRAGAL

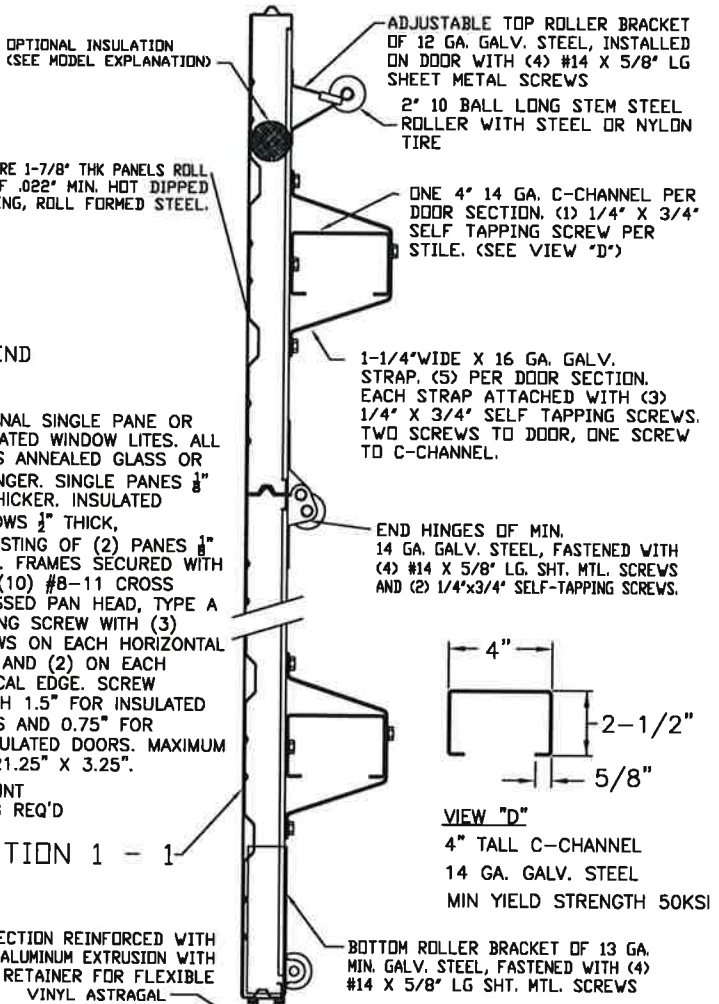

OPTIONAL INSULATION (SEE MODEL EXPLANATION)

SECTIONS ARE 1-7/8" THK PANELS ROLL FORMED OF .022" MIN. HOT DIPPED GALVANIZING, ROLL FORMED STEEL.

DOUBLE END STILES

OPTIONAL SINGLE PANE OR INSULATED WINDOW LITES. ALL PANES ANNEALED GLASS OR STRONGER. SINGLE PANES 1/4" OR THICKER. INSULATED WINDOWS 1/2" THICK, CONSISTING OF (2) PANES 1/4" THICK. FRAMES SECURED WITH QTY. (10) #8-11 CROSS RECESSED PAN HEAD, TYPE A TAPPING SCREW WITH (3) SCREWS ON EACH HORIZONTAL EDGE AND (2) ON EACH VERTICAL EDGE. SCREW LENGTH 1.5" FOR INSULATED DOORS AND 0.75" FOR UNINSULATED DOORS. MAXIMUM DLO 21.25" X 3.25".

TWO POINT LOCKING REQ'D

SECTION 1 - 1

BOTTOM SECTION REINFORCED WITH TEMPERED ALUMINUM EXTRUSION WITH INTEGRAL RETAINER FOR FLEXIBLE VINYL ASTRAGAL

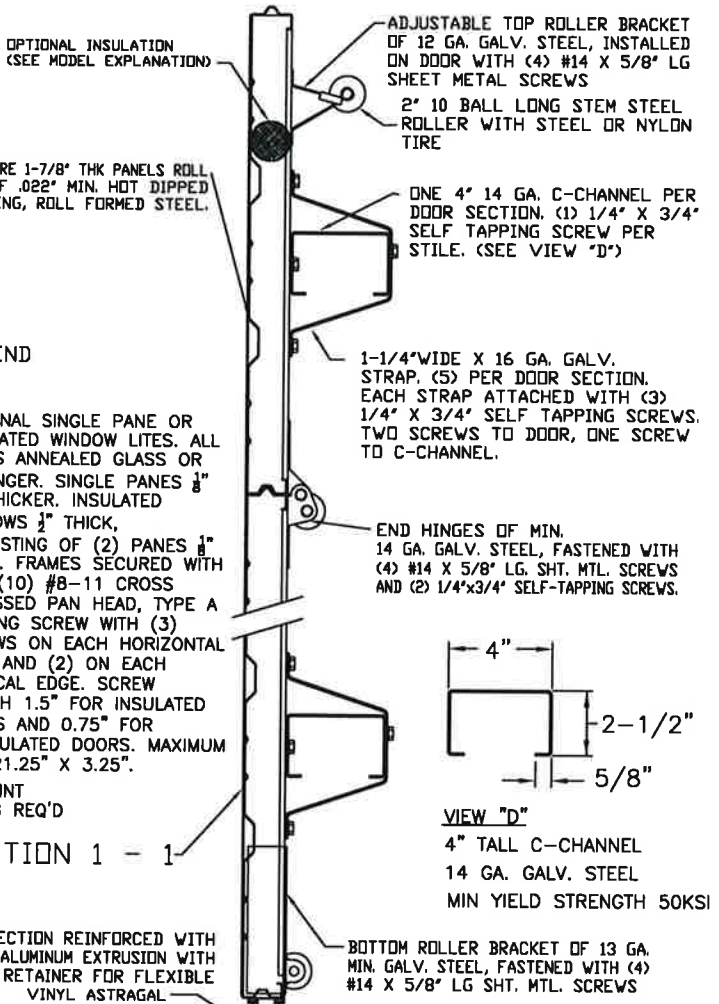

OPTIONAL INSULATION (SEE MODEL EXPLANATION)

SECTIONS ARE 1-7/8" THK PANELS ROLL FORMED OF .022" MIN. HOT DIPPED GALVANIZING, ROLL FORMED STEEL.

DOUBLE END STILES

OPTIONAL SINGLE PANE OR INSULATED WINDOW LITES. ALL PANES ANNEALED GLASS OR STRONGER. SINGLE PANES 1/4" OR THICKER. INSULATED WINDOWS 1/2" THICK, CONSISTING OF (2) PANES 1/4" THICK. FRAMES SECURED WITH QTY. (10) #8-11 CROSS RECESSED PAN HEAD, TYPE A TAPPING SCREW WITH (3) SCREWS ON EACH HORIZONTAL EDGE AND (2) ON EACH VERTICAL EDGE. SCREW LENGTH 1.5" FOR INSULATED DOORS AND 0.75" FOR UNINSULATED DOORS. MAXIMUM DLO 21.25" X 3.25".

TWO POINT LOCKING REQ'D

SECTION 1 - 1

BOTTOM SECTION REINFORCED WITH TEMPERED ALUMINUM EXTRUSION WITH INTEGRAL RETAINER FOR FLEXIBLE VINYL ASTRAGAL

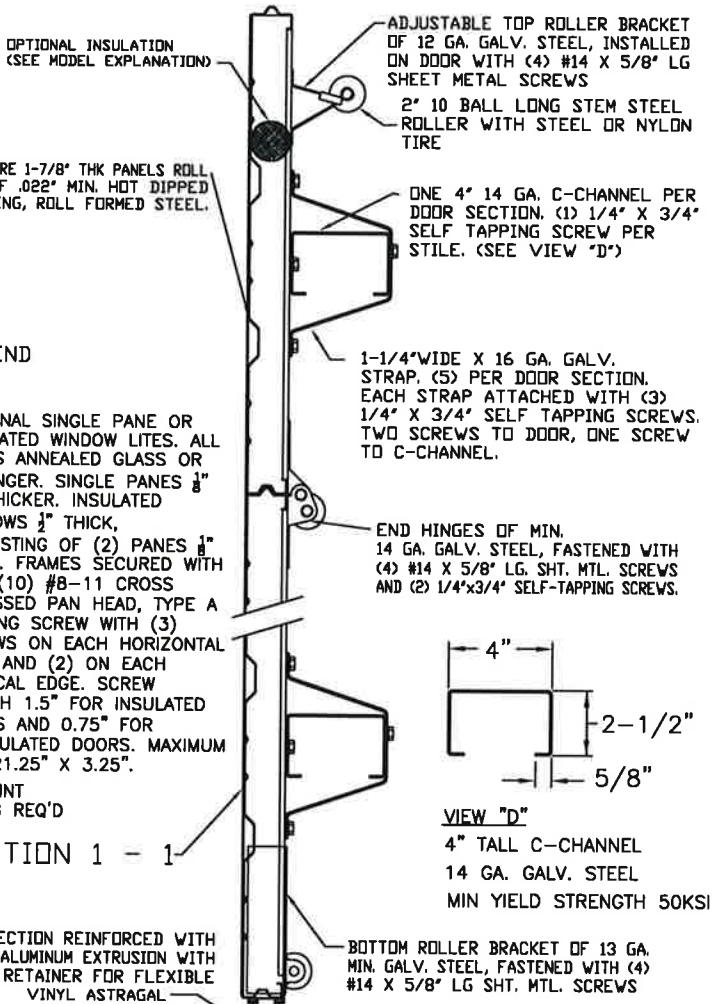

OPTIONAL INSULATION (SEE MODEL EXPLANATION)

SECTIONS ARE 1-7/8" THK PANELS ROLL FORMED OF .022" MIN. HOT DIPPED GALVANIZING, ROLL FORMED STEEL.

DOUBLE END STILES

OPTIONAL SINGLE PANE OR INSULATED WINDOW LITES. ALL PANES ANNEALED GLASS OR STRONGER. SINGLE PANES 1/4" OR THICKER. INSULATED WINDOWS 1/2" THICK, CONSISTING OF (2) PANES 1/4" THICK. FRAMES SECURED