

CLOPAY MODEL 3200 (24 GA MIN EXT SKIN)  
 CLOPAY MODEL 3220 (20 GA MIN EXT SKIN)  
 HOLMES MODEL 240/240G (24 GA MIN EXT SKIN)

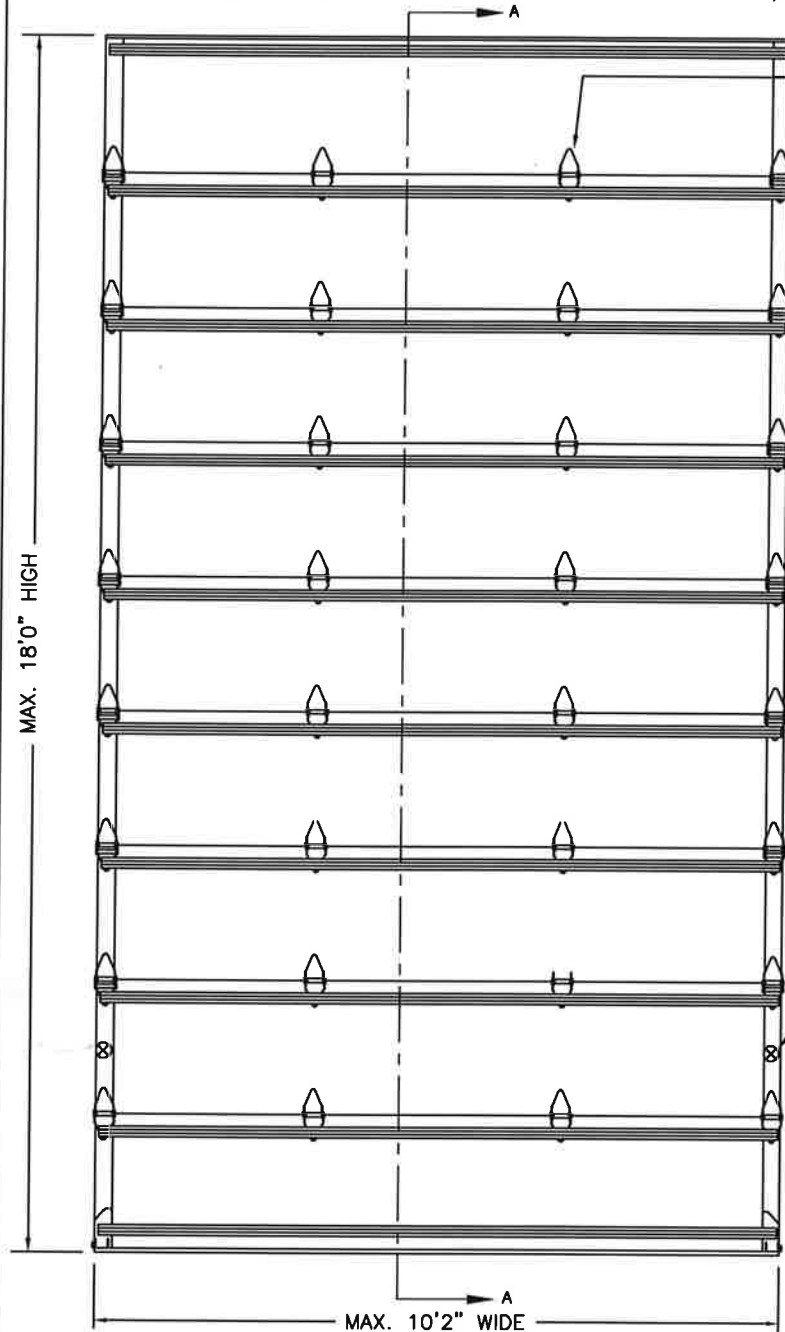

INSIDE ELEVATION

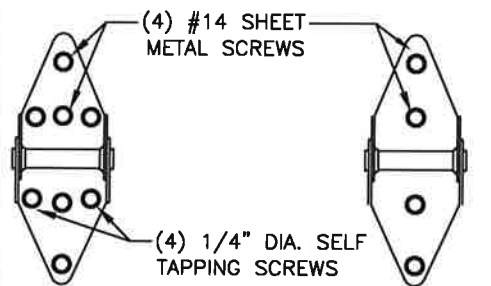

14 GA. END HINGE 14 GA. INTERMEDIATE HINGE

(1) INTER. HINGE ON DOORS UP TO 9'2"W (2) INTER. HINGES ON DOORS UP TO 10'2"W

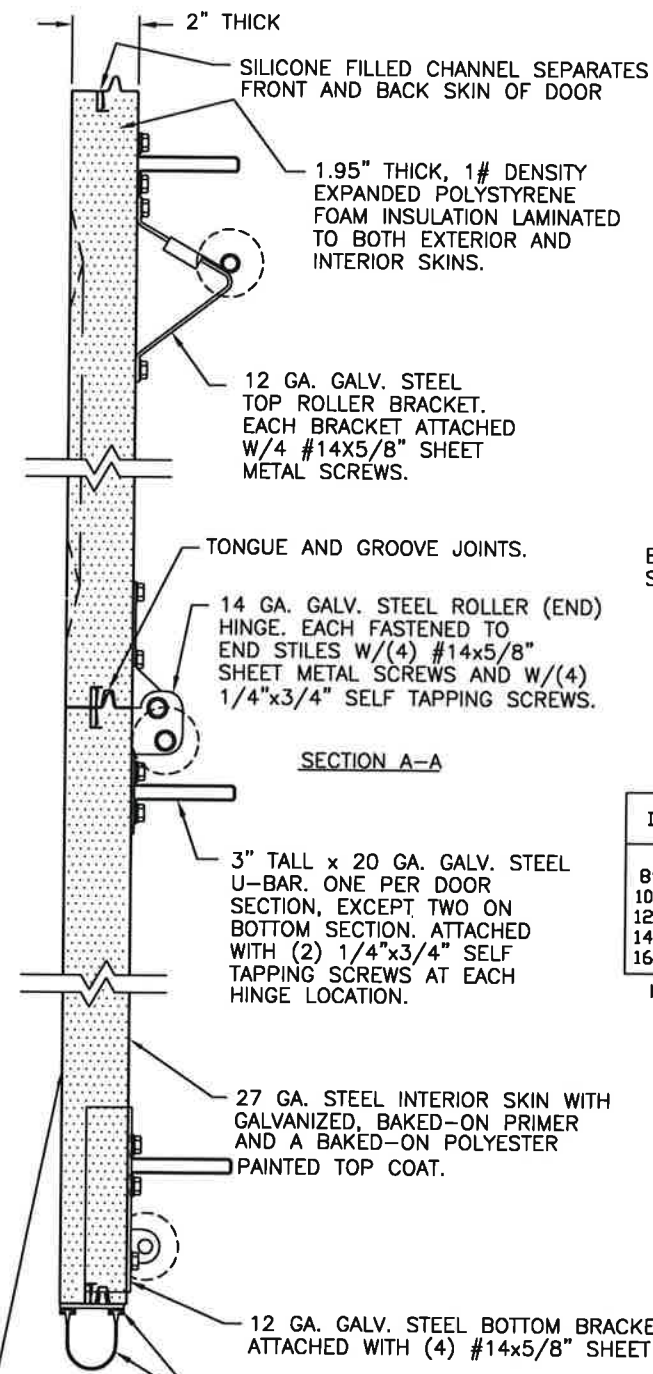

SECTION A-A

THE SUPPORTING STRUCTURAL ELEMENTS ARE TO BE DESIGNED BY THE BUILDING ARCHITECT OR ENGINEER OF RECORD FOR THE LOADS SHOWN ON THIS DRAWING.

STATE OF OHIO  
 MARK W. WESTERFIELD  
 3/8/22  
 91513

THIS PRODUCT COMPLIES WITH THE 2018 IBC/IRC.

REV	DATE	DESCRIPTION
10	06/2013	REMOVE GLAZING OPTION
11	08/2016	REMOVE WIND SPEED TABLE.
12	02/2022	REVISED FOR TDI

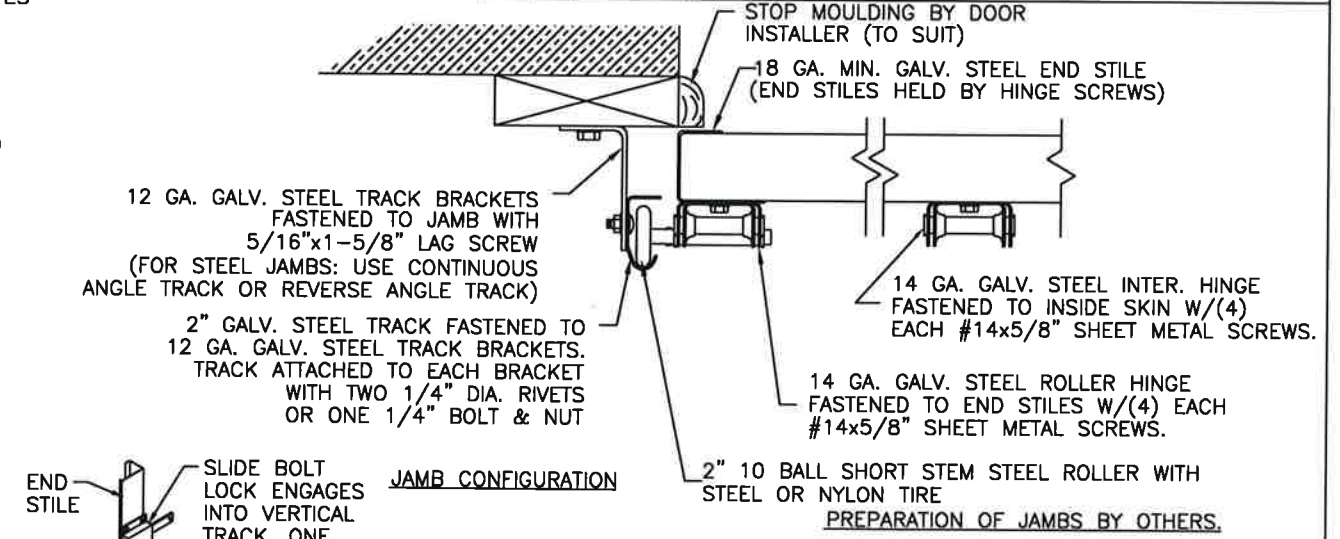

JAMB CONFIGURATION

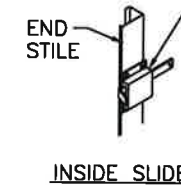

INSIDE SLIDE BOLT

DOOR HEIGHT 'A'	NUMBER OF SECTIONS
UP TO 8'-0"	4
8'-3" THRU 10'-0"	5
10'-3" THRU 12'-0"	6
12'-3" THRU 14'-0"	7
14'-3" THRU 16'-0"	8
16'-3" THRU 18'-0"	9

MAX. SECTION HEIGHT: 24"

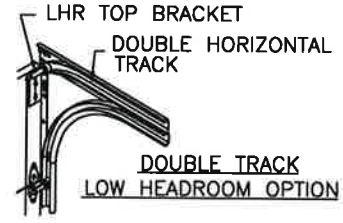

DOUBLE TRACK LOW HEADROOM OPTION

DESIGN ENGINEER: MARK WESTERFIELD, P.E.  
 FLORIDA P.E. #48495, NC P.E. #23832, TEXAS P.E. #91513  
 DESIGN LOADS: +37.0 PSF & -40.0 PSF  
 TEST LOADS: +55.5 PSF & -60.0 PSF

THE OPTIONAL GLAZING SHOWN ON THIS DRAWING MEETS THE WIND LOAD REQUIREMENTS OF THE FLORIDA BUILDING CODE OR INTERNATIONAL BUILDING CODE BUT DOES NOT MEET THE IMPACT RESISTANT REQUIREMENT FOR WINDBORNE DEBRIS REGIONS (REF. CHAPTER 16 FBC/IBC)

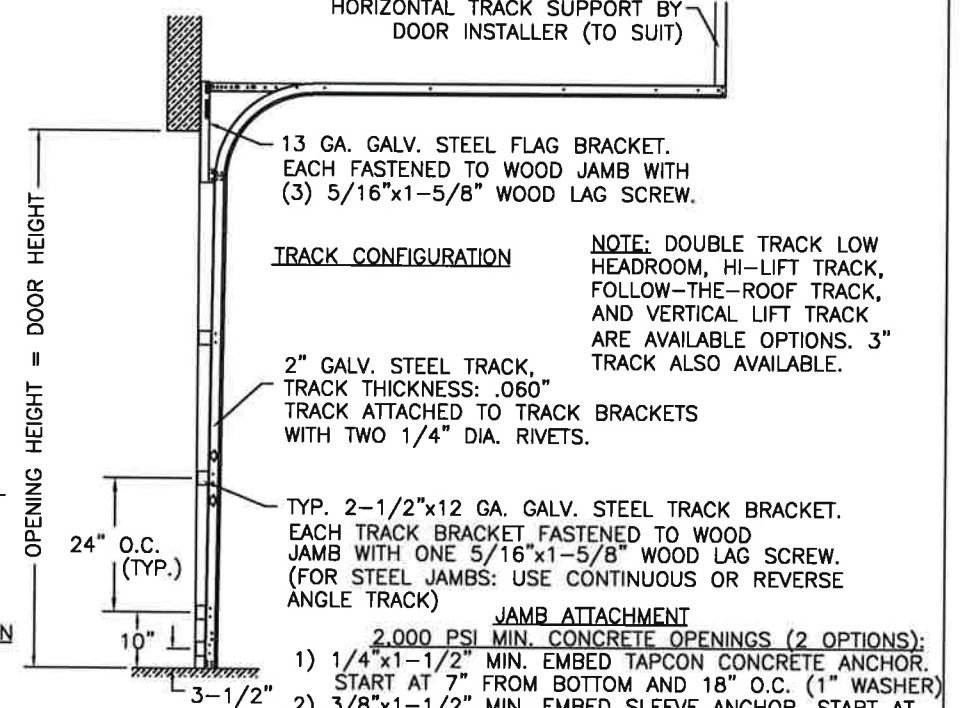

TRACK CONFIGURATION

NOTE: DOUBLE TRACK LOW HEADROOM, HI-LIFT TRACK, FOLLOW-THE-ROOF TRACK, AND VERTICAL LIFT TRACK ARE AVAILABLE OPTIONS. 3" TRACK ALSO AVAILABLE.

JAMB ATTACHMENT

- 2,000 PSI MIN. CONCRETE OPENINGS (2 OPTIONS):
- 1/4"x1-1/2" MIN. EMBED TAPCON CONCRETE ANCHOR. START AT 7" FROM BOTTOM AND 18" O.C. (1" WASHER)
  - 3/8"x1-1/2" MIN. EMBED SLEEVE ANCHOR. START AT 7" FROM BOTTOM AND 21" O.C. (WASHER INCLUDED)

STEEL OPENINGS (2 OPTIONS):

- 1/8"x1" LONG FILLET WELD (E60XX ELECTRODE MIN.). WELD TO BE LOCATED VERTICALLY ON ANGLE AT 24" CENTER AND TACK WELD TOE OF ANGLE AT SAME SPACING.
- 5/16"x1" SELF TAPPING SCREW. START AT 7" FROM BOTTOM AND 24" O.C.

WOOD FRAME OPENINGS (1 OPTION):

- 3/8" X 1-1/2" MIN. EMBED LAG SCREW W/ 1-1/8" DIA. WASHER. MIN. 24" O.C.



CLOPAY CORPORATION  
 8585 DUKE BLVD.  
 MASON, OH 45040  
 (513) 770 - 4800

Clopay Corporation All Rights Reserved.

MANUFACTURING PRODUCT CODE: MPC: C-DSIE-1F448	WINDLOAD RATING W6	MAX DOOR SIZE: 10'2"W x 18'0"H
DATE: 4/18/96	DESCRIPTION: COMM 2" EPS: +37/-40 PSF DESIGN	
DRAWN BY: MWW	DRAWING NUMBER: B 101617	
CHECKED BY:		