



## Supplemental Instructions Overlay Carriage House Doors

 <b>CAUTION</b>	<p><b>Higher wind pressures and larger doors require additional reinforcement.</b></p> <p><b>Premature failure of door system may result from improper application.</b></p> <p><b>See chart in lower left corner of drawing sheet one for the approved wind pressures and door sizes.</b></p>
--	---

 <b>WARNING</b>	<p><b>These supplemental instructions do not contain basic door installation steps and related safety information.</b></p> <p><b>Failure to follow basic installation steps and related safety information may result in injury or death.</b></p> <p><b>Door installers must follow a primary instruction manual for basic door installation steps and related safety information.</b></p>
--	--

The correct selection of door and framing materials in adherence with local building code directives is the responsibility of the building owner/designer. Use of a reinforced garage door does not constitute automatic compliance with any building code. Local building code officials determine compliance criteria.

A locking system must be installed if the door is not electrically operated.

See drawing for stop molding requirements, when door is not more than 1" wider than opening. When using stop molding, secure molding with minimum 8d nails or 2-1/2" long screws.

Professional Engineer's seal provided only for verification of wind load construction details. Printed copies of this document are not considered signed and sealed and the signature must be verified on any electronic copies.

John E. Scates, P.E.  
2560 King Arthur, Ste 124-54  
Lewisville, Texas 75056  
TXPE 56308, F-2203  
Florida P.E. # 51737

# For Use With Drawing Number Z9-18-04307

## Strut Placement

Section Number	Door Height						
	6'-0" to 8'-0"	8'-3" to 10'-0"	10'-3" to 12'-0"	12'-3" to 14'-0"	14'-3" to 16'-0"	16'-3" to 18'-0"	18'-3" to 20'-0"
10	N/A	N/A	N/A	N/A	N/A	N/A	1 at Detail A
9	N/A	N/A	N/A	N/A	N/A	1 at Detail A	1 at Detail A 1 at Detail B
8	N/A	N/A	N/A	N/A	1 at Detail A	1 at Detail A 1 at Detail B	1 at Detail A 1 at Detail B
7	N/A	N/A	N/A	1 at Detail A	1 at Detail A 1 at Detail B	1 at Detail A 1 at Detail B	1 at Detail A 1 at Detail B
6	N/A	N/A	1 at Detail A	1 at Detail A 1 at Detail B	1 at Detail A 1 at Detail B	1 at Detail A 1 at Detail B	1 at Detail A 1 at Detail B
5	N/A	1 at Detail A	1 at Detail A 1 at Detail B	1 at Detail A 1 at Detail B	1 at Detail A 1 at Detail B	1 at Detail A 1 at Detail B	1 at Detail A 1 at Detail B
4	1 at Detail A	1 at Detail A 1 at Detail B	1 at Detail A 1 at Detail B	1 at Detail A 1 at Detail B	1 at Detail A 1 at Detail B	1 at Detail A 1 at Detail B	1 at Detail A 1 at Detail B
3	1 at Detail A 1 at Detail B	1 at Detail A 1 at Detail B	1 at Detail A 1 at Detail B	1 at Detail A 1 at Detail B	1 at Detail A 1 at Detail B	1 at Detail A 1 at Detail B	1 at Detail A 1 at Detail B
2	1 at Detail A 1 at Detail B	1 at Detail A 1 at Detail B	1 at Detail A 1 at Detail B	1 at Detail A 1 at Detail B	1 at Detail A 1 at Detail B	1 at Detail A 1 at Detail B	1 at Detail A 1 at Detail B
1	1 at Detail A	1 at Detail A	1 at Detail A	1 at Detail A	1 at Detail A	1 at Detail A	1 at Detail A

### Push Nut Detail (use on all rollers)

use 3/8" I. D. on bottom fixture roller stem  
use 7/16" I. D. on end hinge and top fixture roller stems

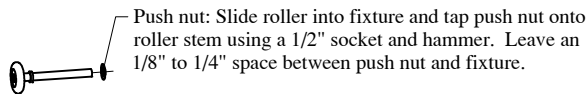

### Additional Push Nut Detail

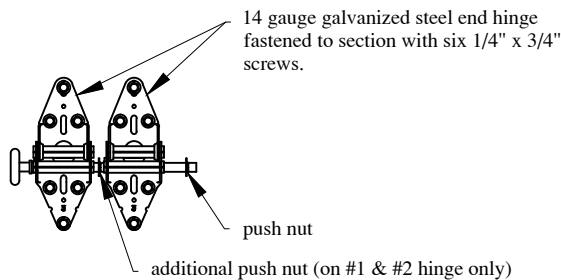

### Track Bracket Spacing

Track bracket spacing shown for doors up to four sections high. Additional door sections may be added for maximum door height depicted on line drawing. Track brackets must be added (per track) for each section and spaced at a distance not greater than the corresponding section height (see line drawing for required quantities).

	Do Not Exceed
G	16"
F	14"
E	15"
D	9"
C	14-1/2"
B	9-1/2"
A	10"

+/- 3" tolerance

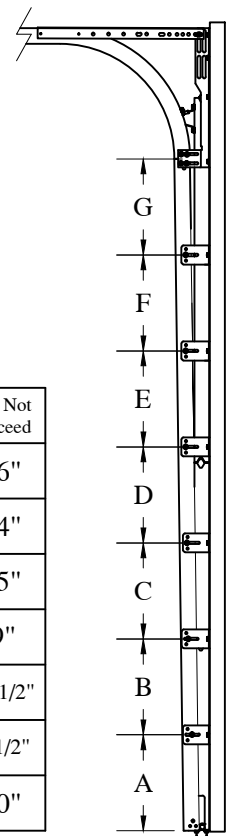

For Use With Drawing Number  
Z9-18-04307

**Strut Placement**

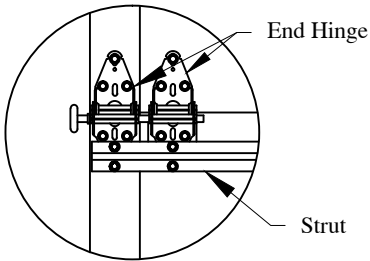

Strut on bottom half of hinge

**Detail B**

Strap attached to cee strut and section with three 1/4" x 3/4" screws.

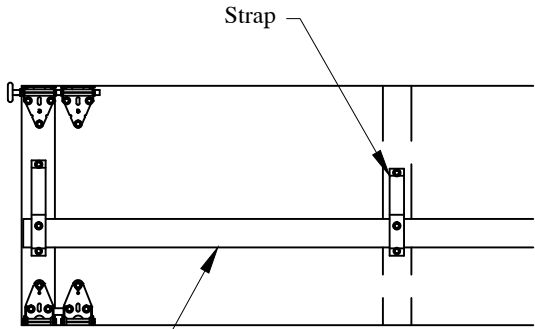

Cee strut

**Detail A**

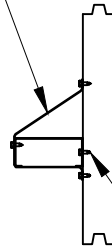

Cee strut attached to section with one 1/4" x 3/4" screw per intermediate stile or backer plate. Use two 1/4" x 1" jambteks per end stile.

Intermediate hinge

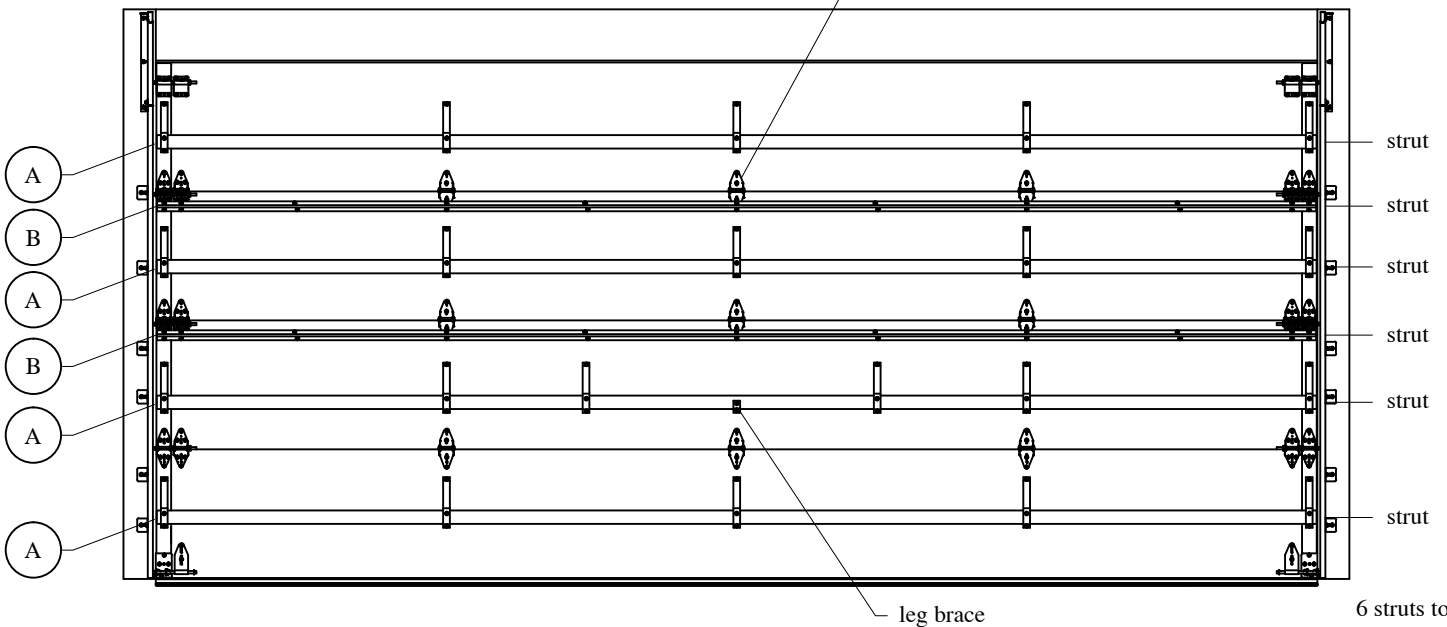

6 struts total

Glazing Options: No Glazing Options are available.

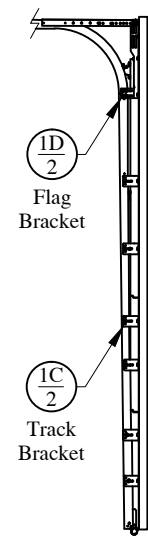
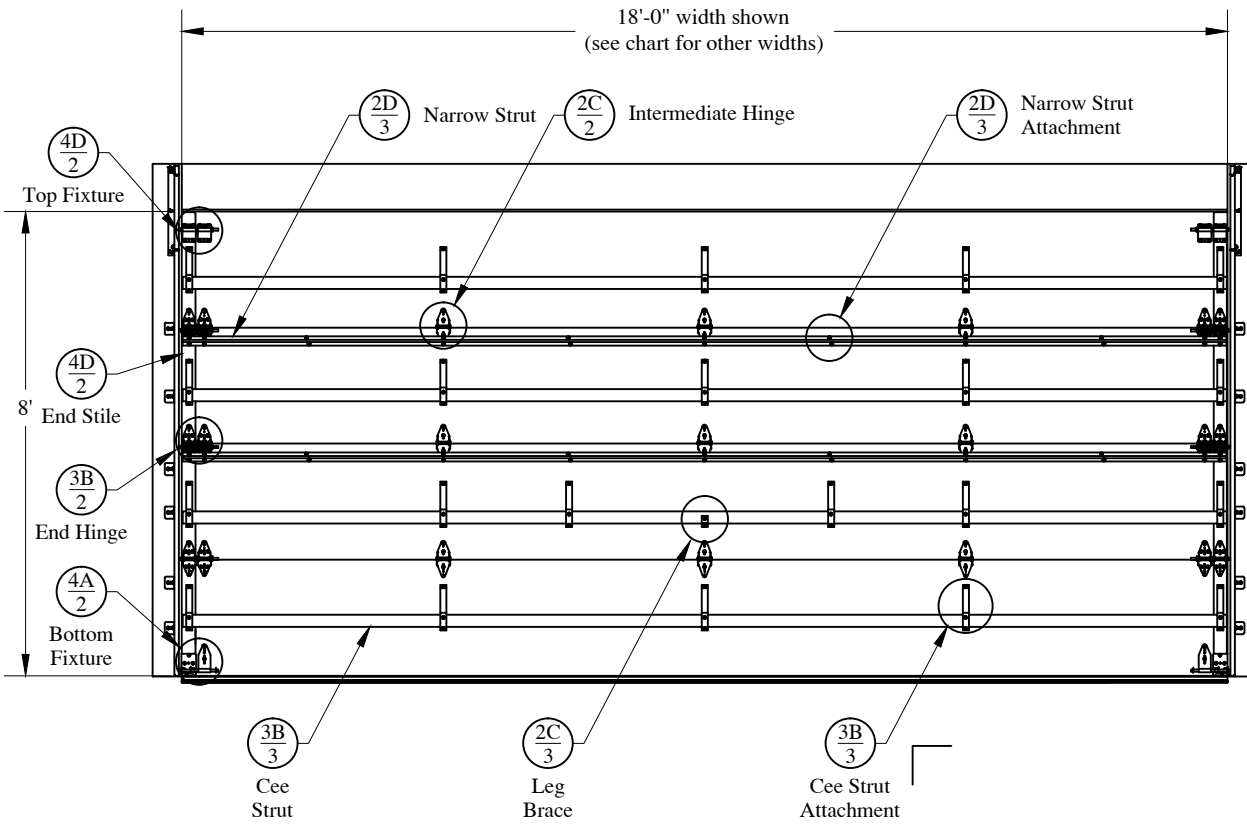

door height	section quantity	cee strut quantity	narrow strut quantity	trk brkt per side
6'-0" to 8'-0"	4	4	2	6
8'-3" to 10'-0"	5	5	3	8
10'-3" to 12'-0"	6	6	4	10
12'-3" to 14'-0"	7	7	5	12
14'-3" to 16'-0"	8	8	6	14
16'-3" to 18'-0"	9	9	7	16
18'-3" to 20'-0"	10	10	8	18

Track bracket quantities shown are for use with grade 2 or better Southern Yellow Pine. Refer to Jamb Attachment Detail supplemental instructions for usage of alternate jamb materials.

Supporting structural elements shall be designed by a registered professional engineer for wind loads shown on this drawing. If door is not electrically operated, a lock must be installed.

Complies with IBC/IRC 2018. Tested per ANSI/DASMA 108  
 Maximum door height: 20'-00"  
 Glazing and door have not been tested for windborne debris.

Width	Design Pressure (PSF)	Stile Qty.
20'-00"	+34.1 / -38.0	11
18'-00"	+42.1 / -46.9	7

Professional Engineer's seal provided only for verification of windload construction details

John E. Scates, P.E.  
 2560 King Arthur, Ste 124-54  
 Lewisville, Texas 75056  
 TXPE 56308, F-2203  
 Florida P.E. # 51737

	SCALE	nts
	DATE	03-24-2022
Models Series: Overlay Carriage House		
C.H.I. Drawing: Z9-18-04307		
page 4 of 5		

Details on some views may have been omitted for clarity.

The vertical wood jamb fasteners may be counter sunk to provide a flat mounting surface. See jamb attachment details for more information about attaching jambs to structure.

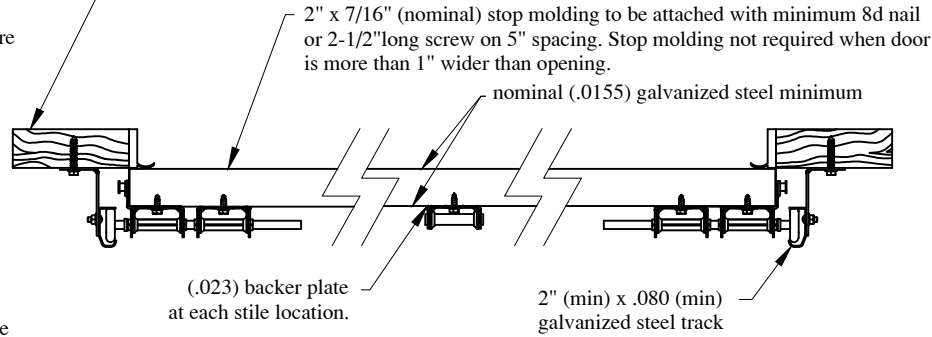
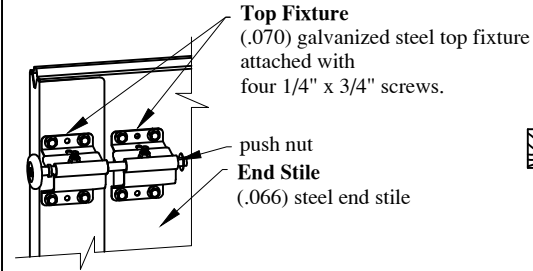

**Flag Bracket**  
(.086) galvanized steel flag bracket attached to wood jamb with three 5/16" x 1-5/8" wood lag screws, to horizontal track with two 1/4" x 5/8" track bolts and nuts and to vertical track with two 1/4" x 5/8" track bolts and nuts.

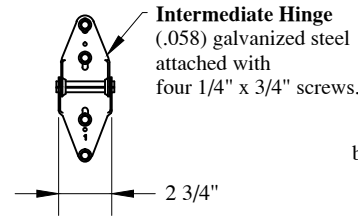
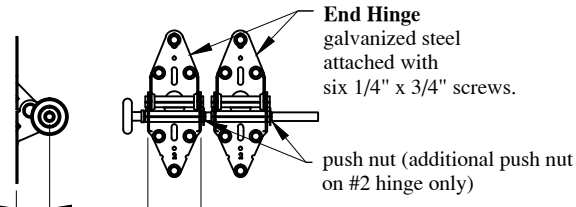
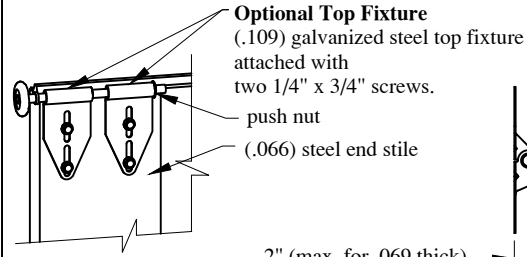
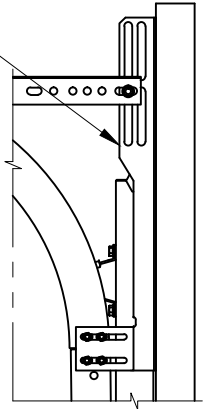

2" (max. for .069 thick)  
4" (max. for .109 thick)

nominal Ø 2" (min.)  
10 (min.) ball roller with steel tire.

9" (min.) high strength stem

**Track Bracket**  
(.102) galvanized steel track bracket attached to wood jamb with one 5/16" x 1-5/8" wood lag screw per bracket and attached to vertical track with one 1/4" x 5/8" track bolt and nut or two 1/4" x 11/32" rivets.

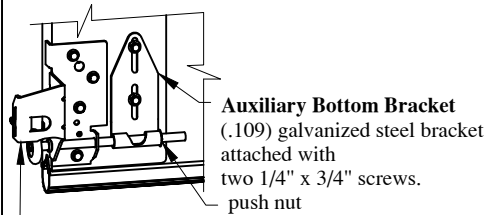
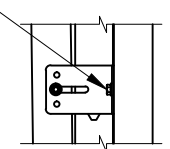

**Optional Bottom Bracket**  
(.109) galvanized steel bottom bracket attached with four red 1/4" x 3/4" screws.

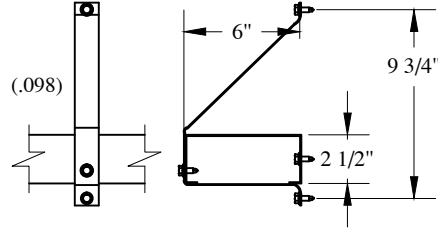

**Cee Strut and Strap Attachment**  
(.055) 50 ksi galvanized steel 6" Cee Strut attached with one 1/4" x 3/4" self tapping screw per stile or backer plate, one additional self tapping screw is used on each end stile. One (.098) strap attached to section with two 1/4" x 3/4" screws and attached to strut with one 1/4" x 3/4" screw at each hinge location.

**Leg Brace**  
One (.098) leg brace on #2 section on the center stile or backer plate and fastened with two 1/4" x 3/4" screws.

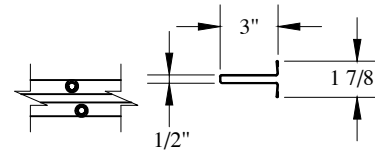
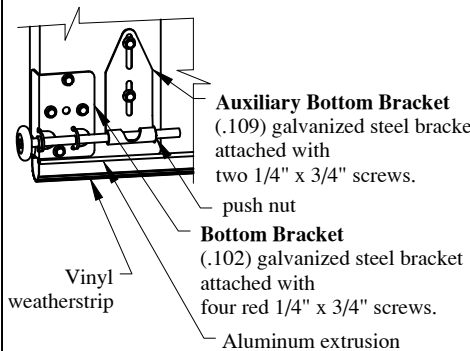
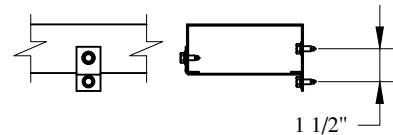

**Narrow Strut and Strap Attachment**  
(.051) 50 ksi galvanized steel 3" strut attached with two 1/4" x 3/4" screws per stile.

John E. Scates, P.E.  
2560 King Arthur, Ste 124-54  
Lewisville, Texas 75056  
TXPE 56308, F-2203  
Florida P.E. # 51737

Professional Engineer's seal provided only for verification of windload construction details

C.H.I.	SCALE	nts
	DATE	03-24-2022
Models Series: Overlay Carriage House		
C.H.I. Drawing: Z9-18-04307		
page 5 of 5		