

KAYCAN LTD

VINYL (PVC) SIDING

INSTALLATION ANCHORAGE DETAILS

GENERAL NOTES:

1. THE PRODUCT SHOWN HEREIN IS DESIGNED TO COMPLY WITH THE 2018 INTERNATIONAL BUILDING CODE AND 2018 INTERNATIONAL RESIDENTIAL CODE AT THE DESIGN PRESSURES STATED HEREIN.
2. THE PRODUCT DETAILS CONTAINED HEREIN ARE BASED UPON SIGNED AND SEALED TESTING BY MOLIMA ARCHITECTURAL PRODUCT TESTING TO ASTM D 5206-19.
 - 2.1. USING THE AVERAGE MAXIMUM SUSTAINED NEGATIVE PRESSURE FROM THE TEST REPORTS, THE DESIGN PRESSURE IS DETERMINED USING ASTM D3679-13, ANNEX A1.2 WHERE:
 - 2.1.1. $DP = (\text{AVERAGE MAXIMUM SUSTAINED NEGATIVE PRESSURE}) / (0.36 \times 1.5)$
 - 2.2. VINYL SIDING IS IN CONFORMANCE TO ASTM D3679.
3. ADEQUACY OF THE EXISTING STRUCTURAL WOOD FRAMING COMPRISING THE ATTACHMENT SUBSTRATE FOR THE SIDING SHALL BE DETERMINED TO BE CAPABLE OF WITHSTANDING AND TRANSFERRING APPLIED PRODUCT LOADS TO THAT STRUCTURE AND IS THE RESPONSIBILITY OF THE ARCHITECT OR ENGINEER OF RECORD FOR THE PROJECT.
4. SUBSTRATES RECEIVING VINYL SIDING SHALL BE CHECKED FOR STRUCTURAL INADEQUACY, CRACKS OR DEFECTS THAT SHALL BE ELIMINATED.
5. INSTALLATION OF SIDING ACCESSORIES AND ACCESSORIES SUCH AS CORNER POSTS, STARTER STRIPS, AND TRIM AROUND OPENINGS SHALL BE DONE IN ACCORDANCE WITH THE 2018 INTERNATIONAL BUILDING CODE AND 2018 INTERNATIONAL RESIDENTIAL CODE AND THE MANUFACTURER'S INSTRUCTIONS.
6. SITE CONDITIONS THAT DEVIATE FROM THE DETAILS OF THIS DRAWING REQUIRE FURTHER ENGINEERING EVALUATION BY A LICENSED PROFESSIONAL ENGINEER OR REGISTERED ARCHITECT.
7. WALLS WHERE VINYL SIDING SHALL BE INSTALLED SHALL BE DESIGNED BY A LICENSED PROFESSIONAL ENGINEER, ARCHITECT OR OTHER DESIGN PROFESSIONAL AS ALLOWED BY AND IN ACCORDANCE WITH THE 2018 INTERNATIONAL BUILDING CODE AND 2018 INTERNATIONAL RESIDENTIAL CODE.
8. WALLS WHERE VINYL SIDING SHALL BE INSTALLED MUST HAVE A WATER-RESISTIVE BARRIER MEETING THE REQUIREMENTS OF THE 2018 INTERNATIONAL BUILDING CODE, SECTION 1404.2 AND 2018 INTERNATIONAL RESIDENTIAL CODE, SECTION R703.2.

VINYL SIDING SPECIFICATIONS:

1. KAYCAN BUILDING PRODUCTS VINYL SIDING IS MANUFACTURED FROM A FORMULATED PVC POWDER COMPOUND MEETING THE SPECIFICATIONS OF ASTM D3679.
2. WALL THICKNESS:
 - 2.1 SEE PROFILE DETAILS ON SHEETS 2, 3 AND 4
3. PANEL LENGTHS:
 - 3.1. 12' - 0" LONG

INSTALLATION NOTES:

1. ANCHORS SHALL BE THE TYPE, SIZE AND EMBEDMENT SHOWN HEREIN FOR RESPECTIVE SUBSTRATE.
2. INSTALLATION ANCHORS SHALL BE AS SHOWN ON THE INSTALLATION SECTION ON SHEET 5
3. MINIMUM EMBEDMENT AND EDGE DISTANCE EXCLUDE WALL FINISHES, WATER-RESISTIVE BARRIERS OR UNDERLAYMENTS
4. FASTENING OF SIDING TO STRUCTURAL WOOD SHEATHING SHALL USE THE FOLLOWING AS MINIMUMS:
 - 4.1. SUBSTRATE SHALL BE APA RATED PS2 7/16" OSB OR APA RATED PS1 7/16" PLYWOOD.
 - 4.1. USE 0.12" DIAMETER x 1-1/2" LONG RING SHANK ROOFING NAIL WITH 7/16" DIAMETER HEAD ON MAXIMUM 16" CENTERS AT 2X FRAMING STUDS
5. ALL FASTENERS SHALL HAVE CORROSION RESISTANT COATINGS OR BE MADE OF CORROSION RESISTANT MATERIALS COMPATIBLE WITH THE SUBSTRATE MATERIALS.
6. WALL STUDS AND STRUCTURAL WOOD SHEATHING SHALL HAVE A MINIMUM SPECIFIC GRAVITY OF 0.42 AND 0.40 RESPECTIVELY.

SHEET	DESCRIPTION
1	GENERAL/INSTALLATION NOTES, SIDING SPEC. AND D.P. CHART
2	D5D ELEGANCE & D4 MARQUIS VINYL SIDING
3	D4D AVANTI & D5 CONTESSA VINYL SIDING
4	D4.5 OCEAN PARK VINYL SIDING, COMPONENTS & BILL OF MATERIALS
5	VERTICAL INSTALLATION CROSS SECTION

DESIGN PRESSURE (PSF) RATING	
SIDING MODEL	DESIGN PRESSURE (PSF) RATING (SEE GENERAL NOTE 2)
D5D ELEGANCE	-111.2
D4 MARQUIS	-126.5
D4D AVANTI	-111.2
D5 CONTESSA	-108
D4.5 OCEAN PARK	-101.9

PROJECT #420-0906									
	B	A	REV	DATE	DATE	DATE	DATE	DATE	DATE
KAYCAN LTD. 1 MEMORIAL DRIVE RICHFORD, VT 05476	DRAWN BY: RJA	DATE: 02/04/13	SCALE: N.T.S.	DRAWING NO: KAY0004	SHEET: 1 OF 5	REV: B	TITLE: GENERAL/INSTALLATION NOTES, SIDING SPEC. AND D.P. CHART		
PTC PRODUCT DESIGN GROUP, LLC Phone: 321.690.1788 PO Box 1000, Ft. Worth, TX 76101 Fax: 321.690.1789 LONGWOOD, FLORIDA 32752 Email: info@ptc-corp.com TX REGISTRATION NO. F-13740									

Robert J. Amoruso
TX P.E. No. 80817

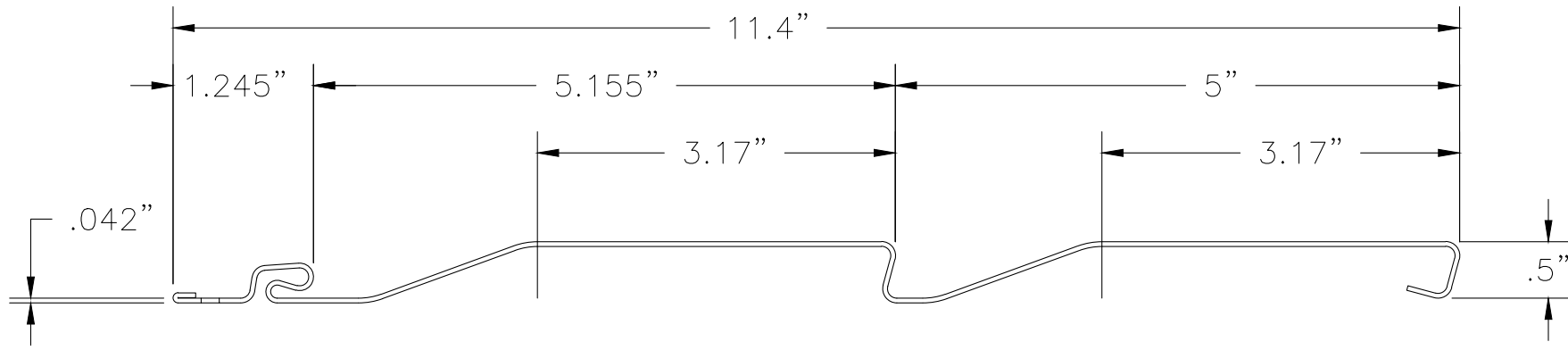

1 D5D ELEGANCE SIDING
EXTRUDED VINYL (PVC) 0.042" THICK

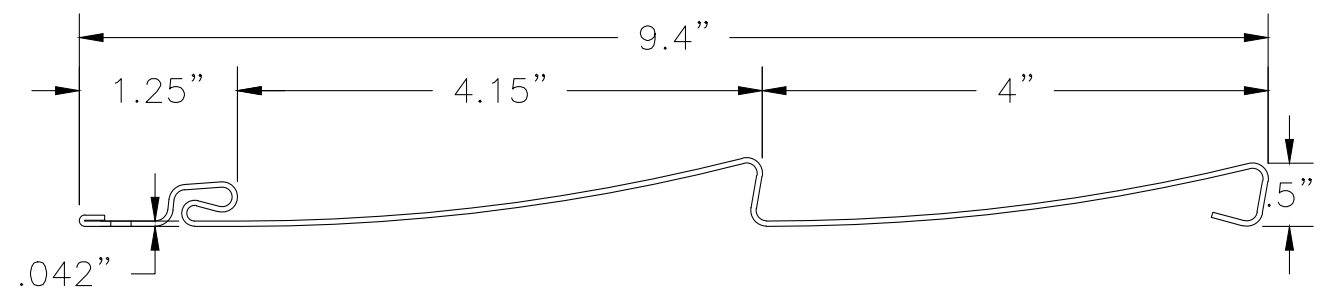
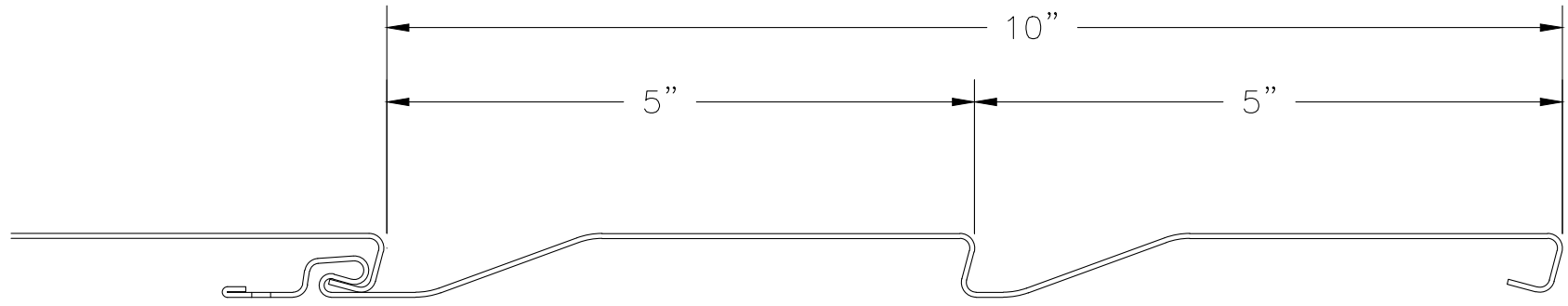

2 D4 MARQUIS SIDING
EXTRUDED VINYL (PVC) 0.042" THICK

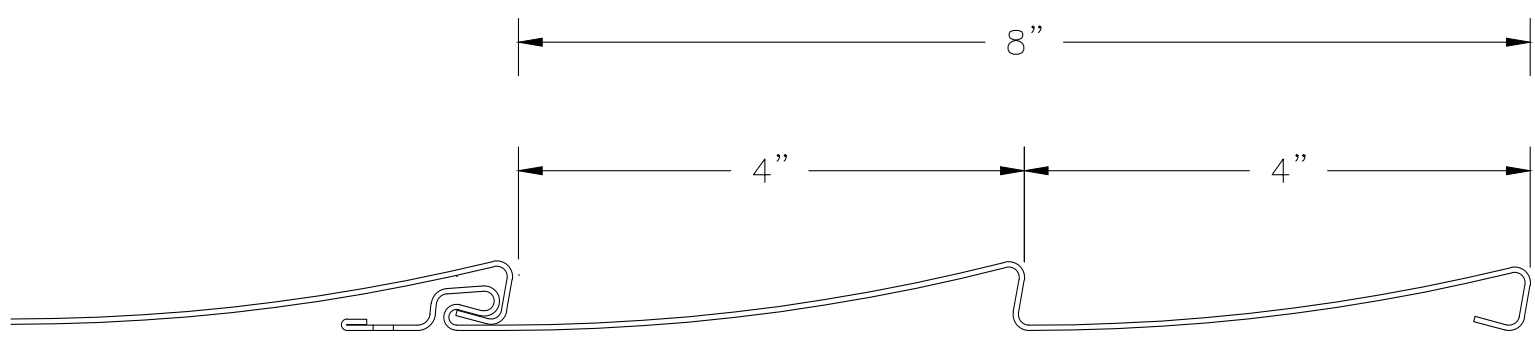

PROJECT #420-0906		RJA	RJA	BY
B	ADD NEW PROFILES	4/7/21	DATE	
A	REVISE D5 DESIGN PRESSURE & DETAILS	5/7/14	DATE	
REV	DESCRIPTION			

KAYCAN LTD. 1 MEMORIAL DRIVE RICHFORD, VT 05476		DRAWN BY: RJA	DATE: 02/04/13
VINYL (PVC) SIDING		SCALE: N.T.S.	DRAWING NO: KAY0004
D5D ELEGANCE & D4 MARQUIS VINYL SIDING		REV: B	SHEET: 2 OF 5
PREPARED BY:		PVC PRODUCT DESIGN GROUP, LLC Phone: 321.690.1788 PO BOX 52075 Longwood, FL 32752 Fax: 321.690.1789 TX REGISTRATION NO. F-13740 Email: info@pvc-corp.com	

Robert J. Amoruso
TX P.E. No. 80817

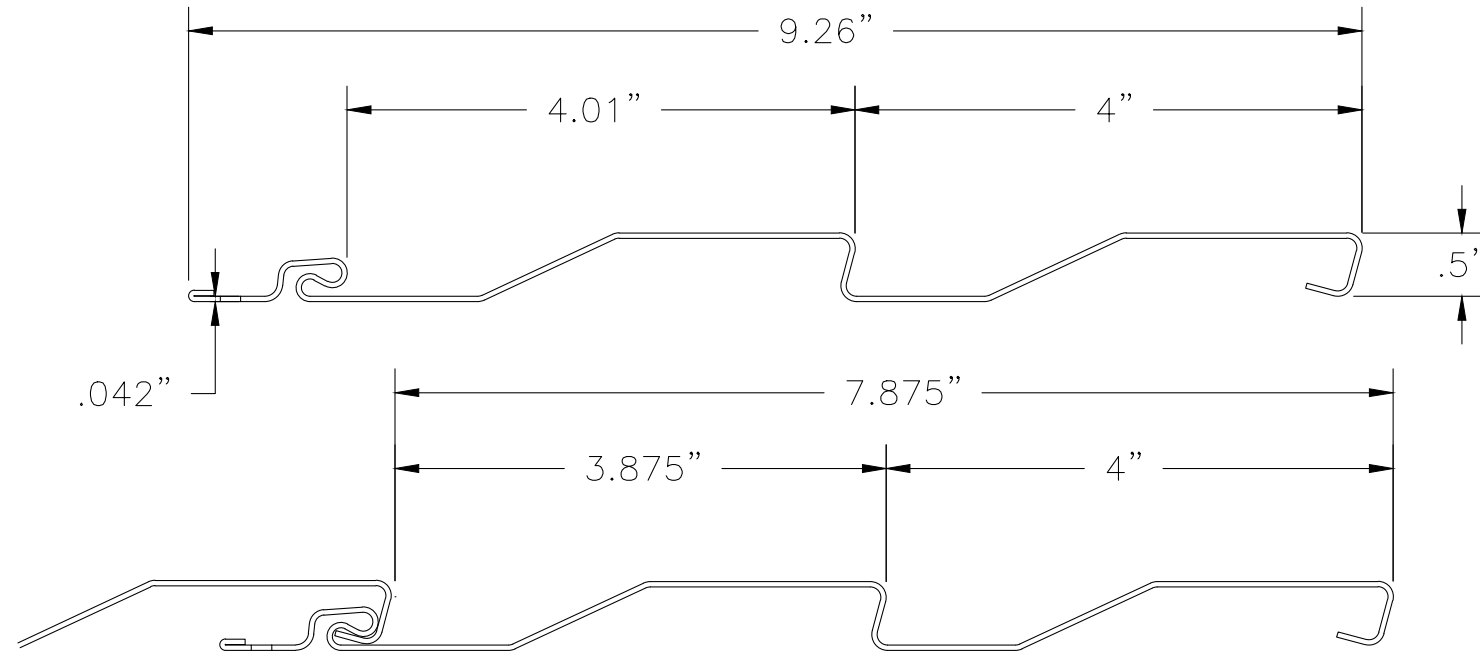

3 D4D AVANTI SIDING
EXTRUDED VINYL (PVC) 0.042" THICK

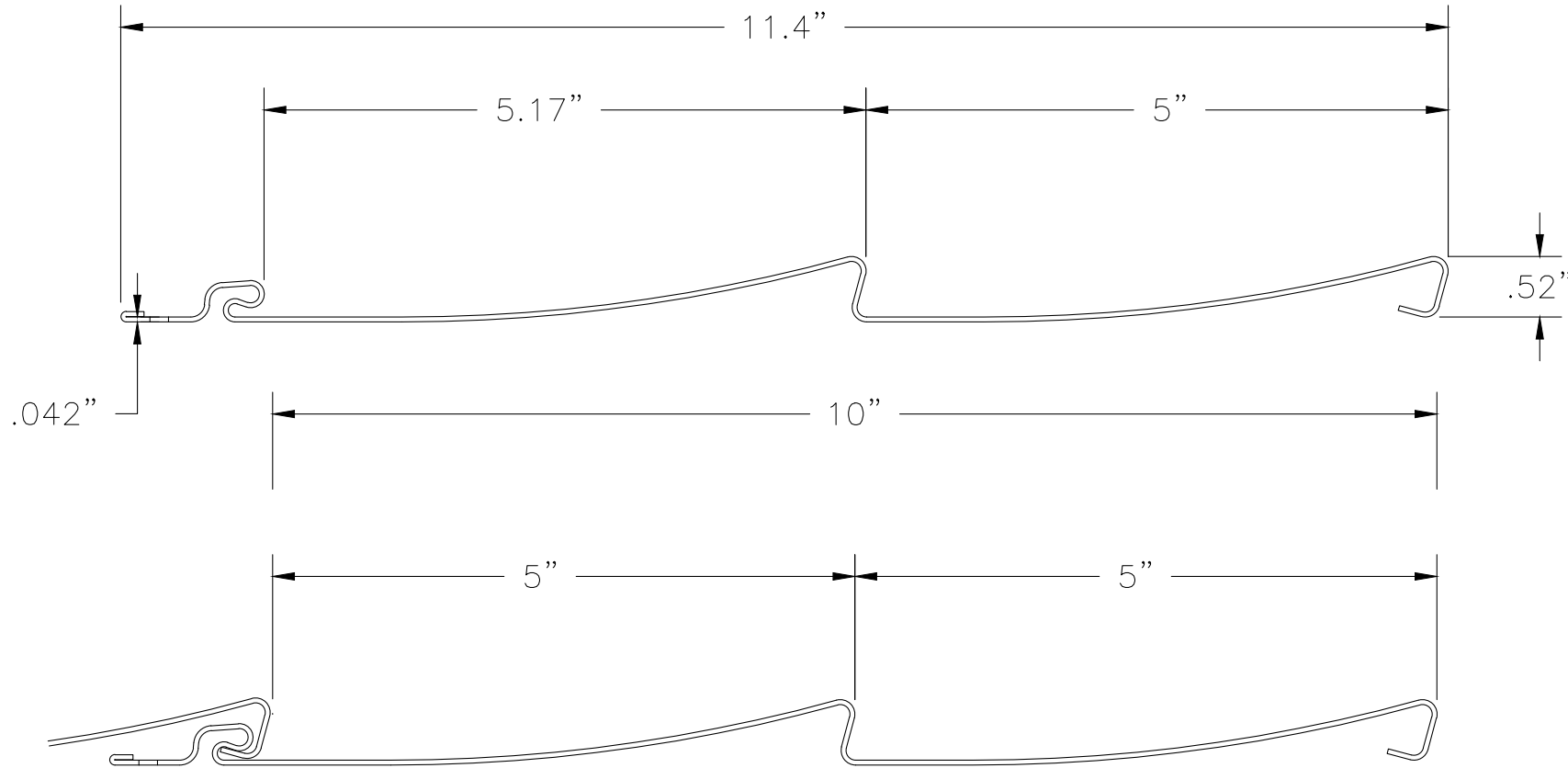

4 D5 CONTESSA SIDING
EXTRUDED VINYL (PVC) 0.042" THICK

PROJECT #420-0906

B	ADD NEW PROFILES	RJA	4/7/21
A	REVISE D5 DESIGN PRESSURE & DETAILS	RJA	5/7/14
REV	DESCRIPTION	DATE	BY

KAYCAN LTD.
1 MEMORIAL DRIVE
RICHFORD, VT 05476

VINYL (PVC) SIDING
D4D AVANTI & D5 CONTESSA VINYL SIDING

DRAWN BY:	RJA	DATE:	02/04/13
SCALE:	N.T.S.	DRAWING NO.:	KAY0004
REV:	B	SHEET:	3 OF 5

PREPARED BY:
RF
PVC PRODUCT DESIGN GROUP, LLC
PO BOX 59075
LONGWOOD, FLORIDA 32752
TX REGISTRATION NO. F-13740
Phone: 321.690.1788
Fax: 321.690.1789
Email: info@pvc-corp.com

Robert J. Amoruso
TX P.E. No. 80817

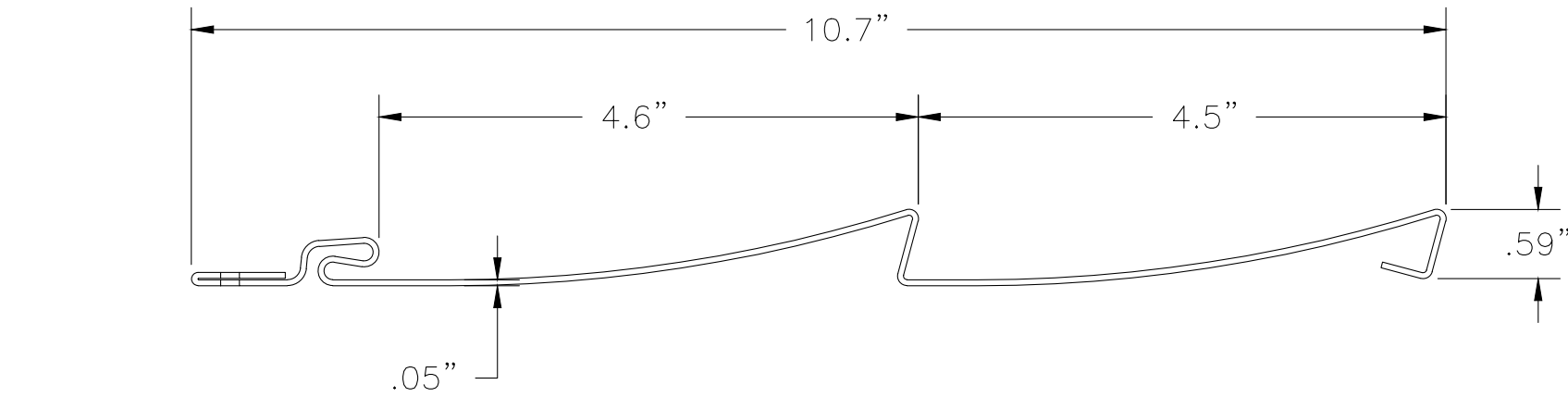

5 D4.5 OCEAN PARK SIDING
EXTRUDED VINYL (PVC) 0.050" THICK

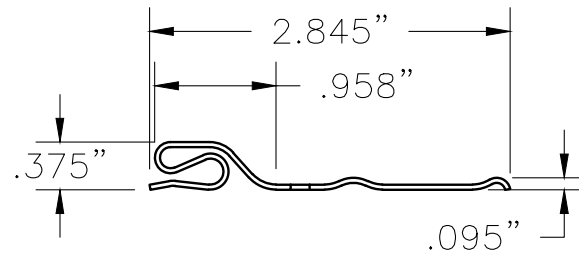
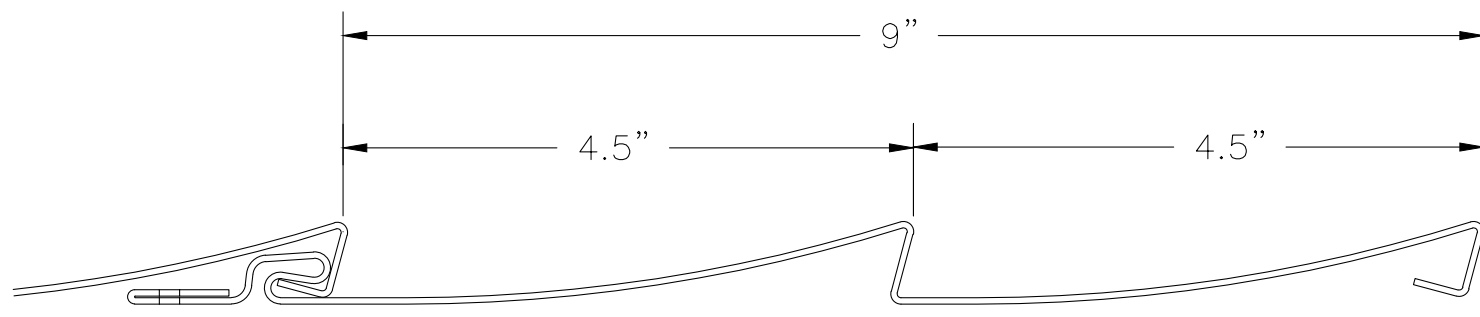

6 STARTER STRIP
EXTRUDED VINYL (PVC)
0.040" THICK

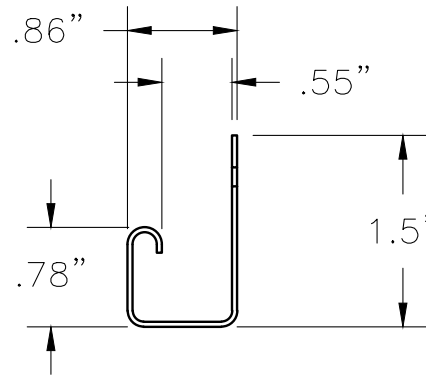

7 J-CHANNEL
EXTRUDED VINYL (PVC)
0.040" THICK

BILL OF MATERIALS		
ITEM	DESCRIPTION	MATERIAL
1	KAYCAN D5D DUTCHLAP ELEGANCE SIDING	VINYL (PVC)
2	KAYCAN D4 MARQUIS SIDING	VINYL (PVC)
3	KAYCAN D4D DUTCHLAP AVANTI SIDING	VINYL (PVC)
4	KAYCAN D5 CONTESSA SIDING	VINYL (PVC)
5	KAYCAN D4.5 OCEAN PARK SIDING	VINYL (PVC)
6	KAYCAN STARTER STRIP	VINYL (PVC)
7	KAYCAN J-CHANNEL	VINYL (PVC)
8	0.12" DIA. x 1-1/2" LONG RING SHANK ROOFING NAIL WITH 7/16" DIA. HEAD MIN.	GALV. STEEL

PROJECT #420-0906

		RJA	BY
	47/21	RJA	DATE
B	ADD NEW PROFILES		
A	REVISE D5 DESIGN PRESSURE & DETAILS	RJA	
REV	DESCRIPTION		

KAYCAN LTD.
1 MEMORIAL DRIVE
RICHFORD, VT 05476

TITLE: D4.5 OCEAN PARK VINYL SIDING, COMPONENTS & BILL OF MATERIALS

PREPARED BY: RJA
SCALE: N.T.S.
REV: B

DATE: 02/04/13
DRAWING NO: KAY0004
SHEET: 4 OF 5

PVC PRODUCT DESIGN GROUP, LLC
PO BOX 52075
LONGWOOD, FLORIDA 32752
TX REGISTRATION NO. F-13740
Phone: 321.690.1788
Fax: 321.690.1789
Email: info@pvc-corp.com

Robert J. Amoruso
TX P.E. No. 80817

EXTERIOR

INTERIOR

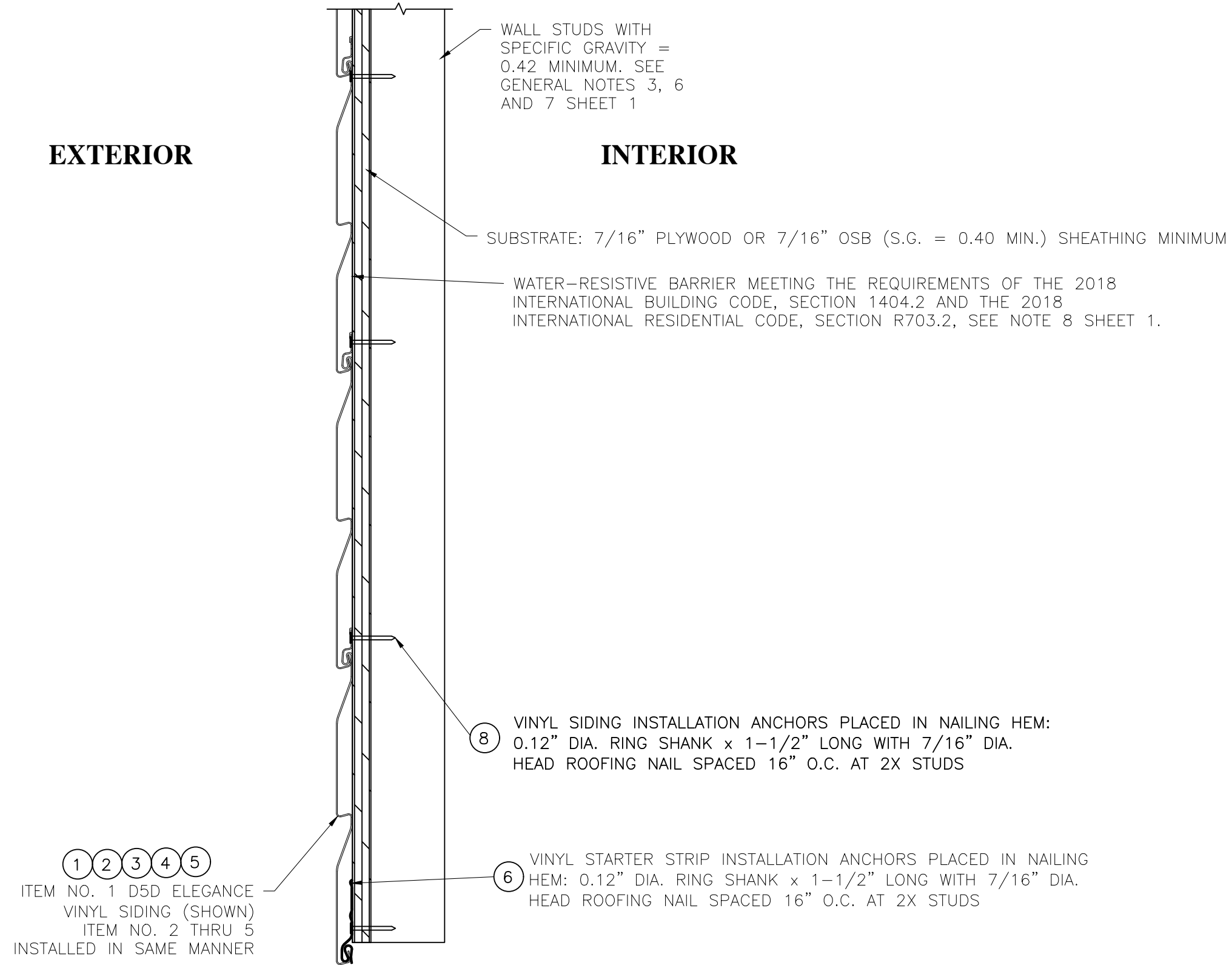

VERTICAL INSTALLATION
CROSS SECTION

PROJECT #420-0906

B	ADD NEW PROFILES	4/7/21	RJA	RJA
A	REVISE D5 DESIGN PRESSURE & DETAILS	5/7/14	RJA	RJA
REV	DESCRIPTION	DATE	BY	BY

KAYCAN LTD.
1 MEMORIAL DRIVE
RICHFORD, VT 05476

VINYL (PVC) SIDING
VERTICAL INSTALLATION CROSS SECTION



PREPARED BY: RJA
SCALE: N.T.S.
REV: B

DATE: 02/04/13
DRAWING NO: KAY0004
SHEET: 5 OF 5

PVC PRODUCT DESIGN GROUP, LLC
PO BOX 58075
LONGWOOD, FLORIDA 32752
TX REGISTRATION NO. F-13740
Phone: 321.690.1788
Fax: 321.690.1789
Email: info@pvc-corp.com

Robert J. Amoruso
TX P.E. No. 80817