

**FIBERGLASS GLAZED  
DOUBLE DOOR  
w/ or w/out SIDELITES  
INSWING/OUTSWING  
"IMPACT"**

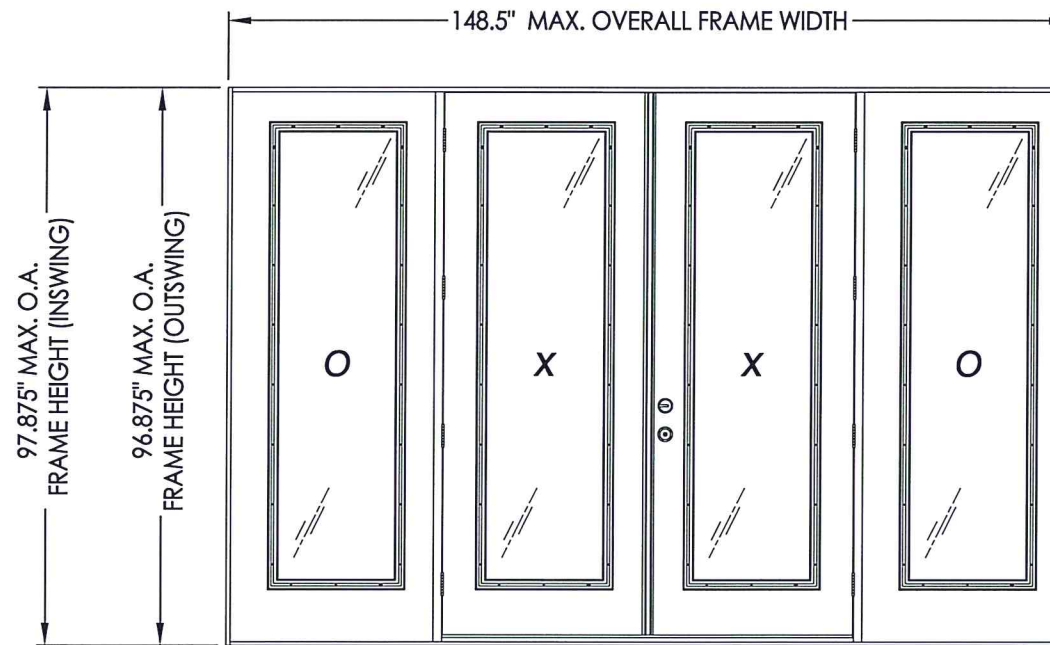
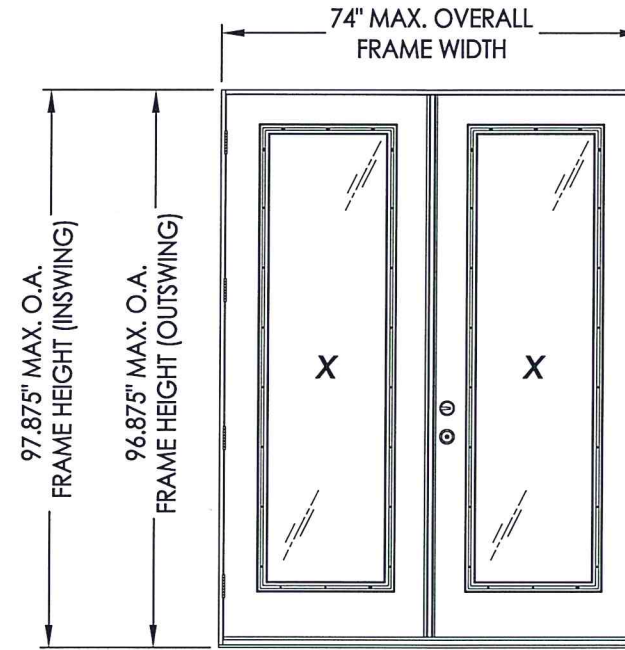

**CONTINUOUS HEAD & SILL**

CONFIGURATION	DESIGN PRESSURE (PSF) INSWING		DESIGN PRESSURE (PSF) OUTSWING	
	POSITIVE	NEGATIVE	POSITIVE	NEGATIVE
XX, OXXO	+50.0	-55.0	+50.0	-50.0

**EVALUATED FOR USE IN THE STATE OF TEXAS**

The Fiberglass Door system described herein complies with the 2018 International Residential Code (IRC), Sections R301 & R609 and the 2018 International Building Code (IBC), Sections 1404.13, 1609, 1709.5, 2403 and 2404 subject to the following conditions:

1. Anchors shall be as listed and spaced as shown in the details. Anchor embedment to base material shall be beyond wall dressing or stucco.
2. This system has been tested and evaluated as a large missile impact protective system for installation in areas that require wind borne debris protection. This product meets missile level "D" as defined in ASTM E 1996.
3. Allowable design pressure requirements must be equal to or less than the design pressure rating shown in the design pressure chart, sheet 1 of this drawing.
4. Conditions not covered by this drawing are subject to further engineering analysis.

**TABLE OF CONTENTS**

SHEET#	DESCRIPTION
1	Typical Elevations, Design Pressures & General Notes
2	Door Panel Details
3	Sidelite Panel Details
4	Elevations
5	Horizontal & Vertical Cross Sections (2X Framing)
6	Horizontal & Vertical Cross Sections (1X Buck)
7	Vertical Cross Sections (Thresholds)
8	Frame Anchoring
9	Hardware Details
10	Bill of Materials & Components



Documents Prepared By: Lyndon F. Schmidt, P.E.  
TEXAS P.E. #104123

**RW** BUILDING CONSULTANTS, INC.  
P.O. Box 230 Valrico FL 33595  
Phone No.: 813.659.9197  
TEXAS BOARD OF PROFESSIONAL ENGINEERS  
CERTIFICATE OF REGISTRATION # F-11852

PRODUCT: MASTERGRAIN  
FIBERGLASS DOOR  
PART OR ASSEMBLY:  
TYPICAL ELEVATION, DESIGN  
PRESSURES & GENERAL NOTES

NO.	DATE	REVISIONS
1	3/05/20	UPDATE TO 2018 IBC/IRC CODE
		LFS
		BY

DATE: 9/04/18  
SCALE: N.T.S.  
DWG. BY: JK  
CHK. BY: LFS  
DRAWING NO.: TX-4893  
SHEET 1 OF 10

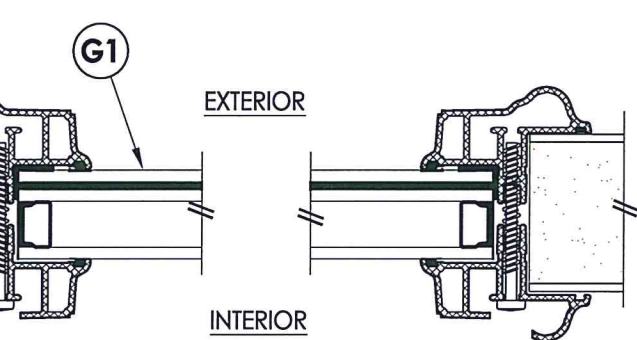
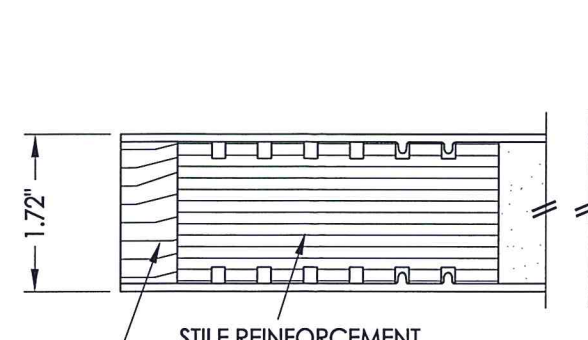

**1**  
**2** **HORIZONTAL CROSS SECTION**

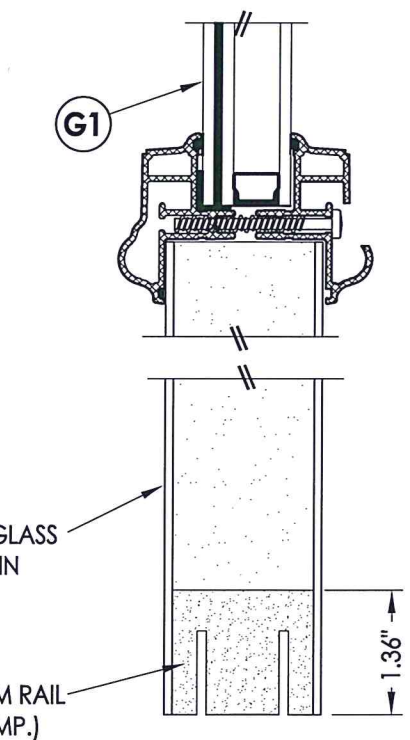
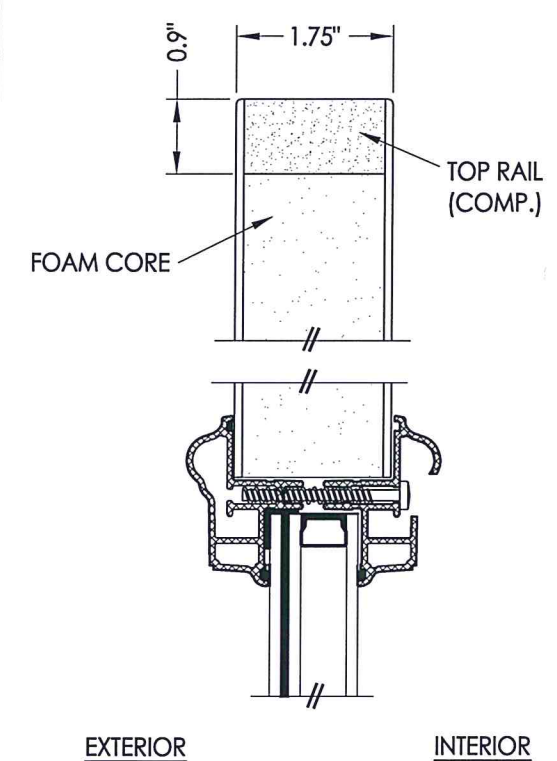
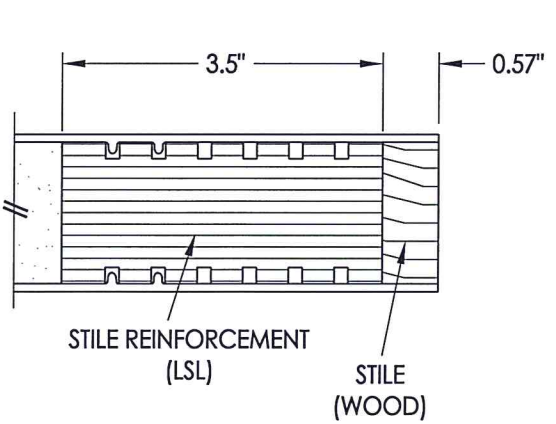

**2**  
**2** **VERTICAL CROSS SECTION**

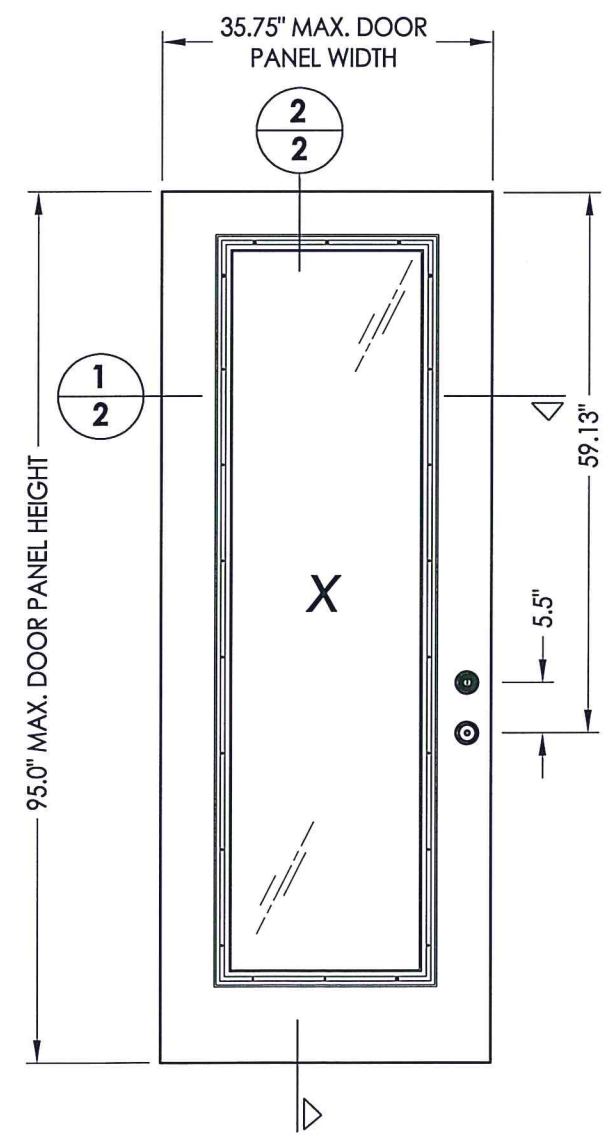

**40** **DOOR PANEL**  
Mastergrain

FIBERGLASS DOOR SKIN: 0.095" MIN. THK.  
FOAM CORE: POLYURETHANE - 1.9 PCF MIN.

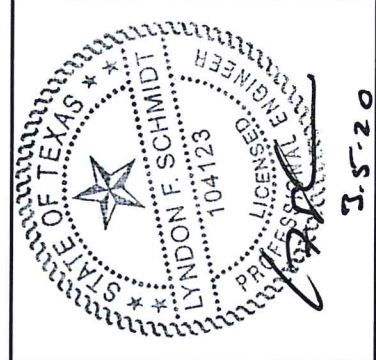

Documents Prepared By: Lyndon F. Schmidt, P.E.  
TEXAS P.E. #104123

**RW** BUILDING CONSULTANTS, INC.  
P.O. Box 230 Vairico FL 33595  
Phone No.: 813.659.9197

TEXAS BOARD OF PROFESSIONAL ENGINEERS  
CERTIFICATE OF REGISTRATION # F-11852

PRODUCT:	MASTERGRAIN FIBERGLASS DOOR
PART OR ASSEMBLY:	DOOR PANEL DETAILS

NO.	DATE	DESCRIPTION	BY
1	3/05/20	UPDATE TO 2018 IBC/IRC CODE	LFS

DATE:	9/04/18
SCALE:	N.T.S.
DWG. BY:	JK
CHK. BY:	LFS
DRAWING NO.:	TX-4893
SHEET	2 OF 10

R:\Clients\Mastergrain PERMANENT\B - Texas Dept of Ins\TDI - DR 991 Fiberglass Door - Glazed Impact (8-0)\Drawings\TX-4891-93.dwg, 3.3

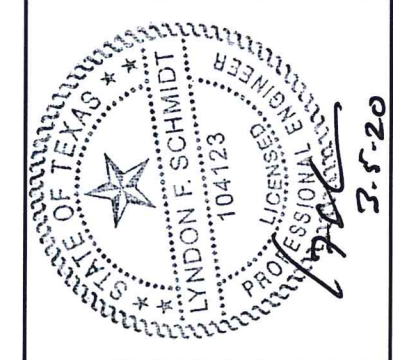
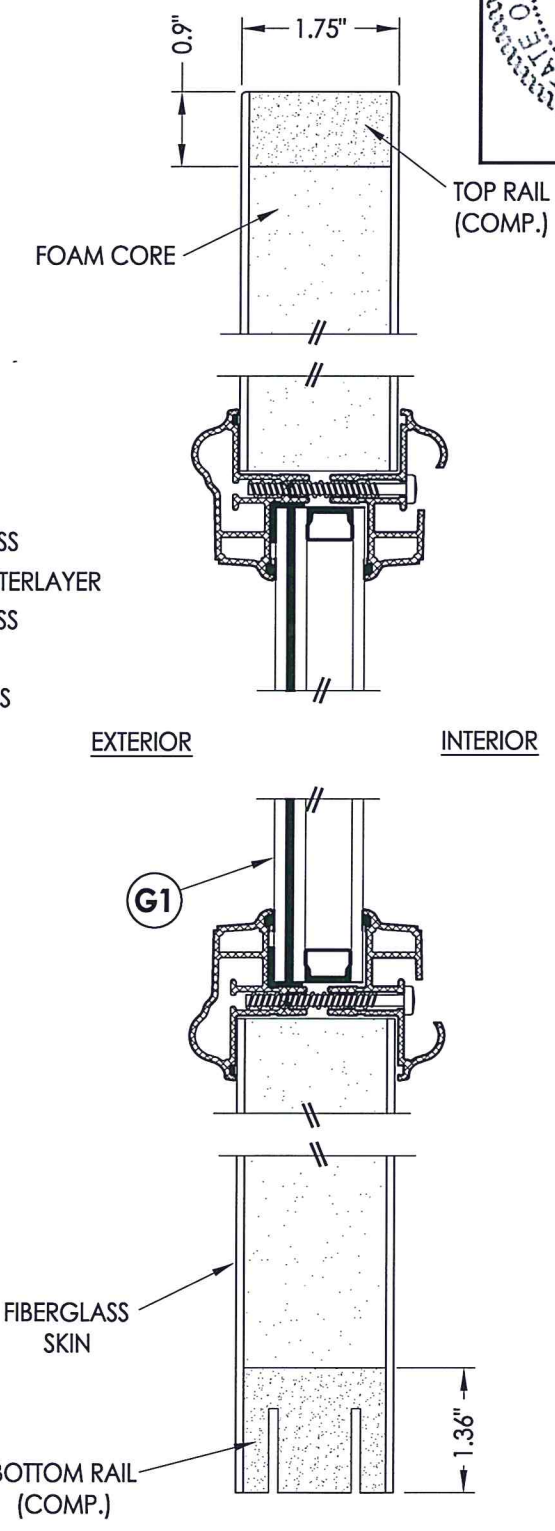
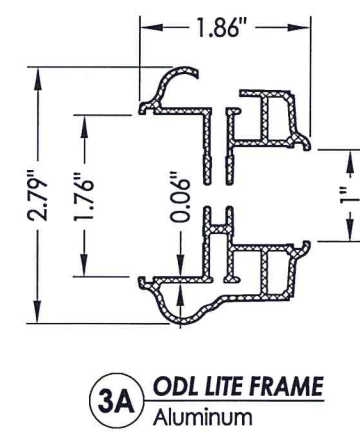
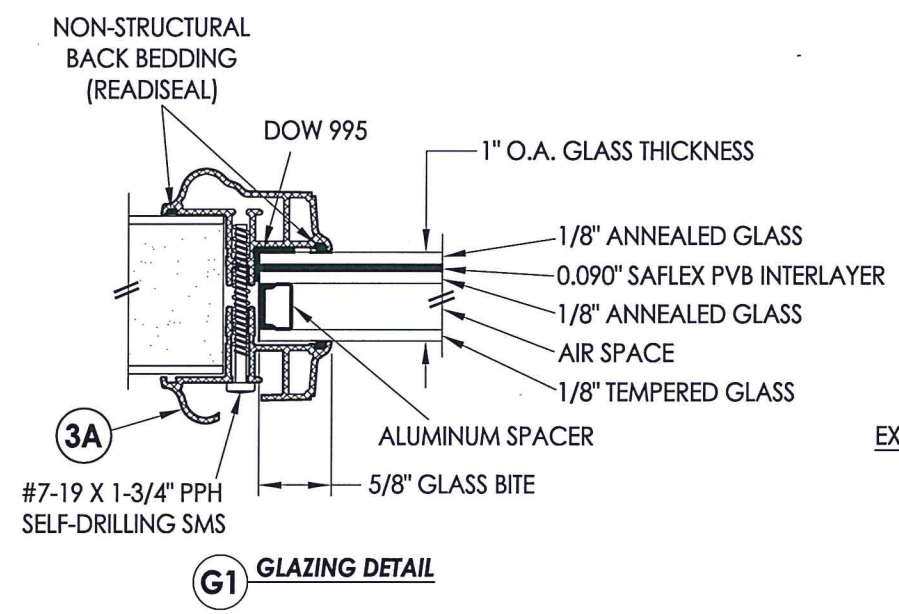
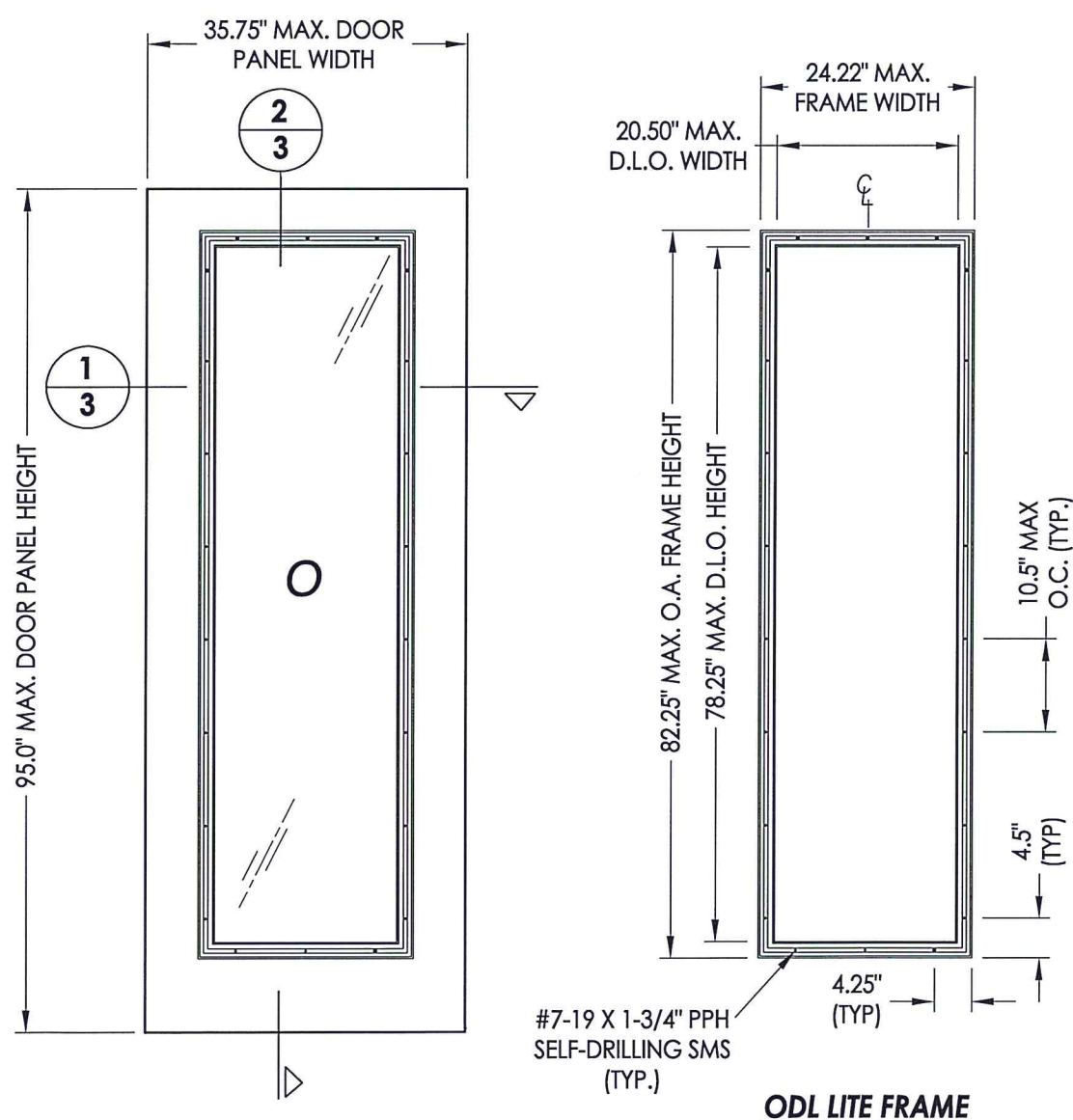
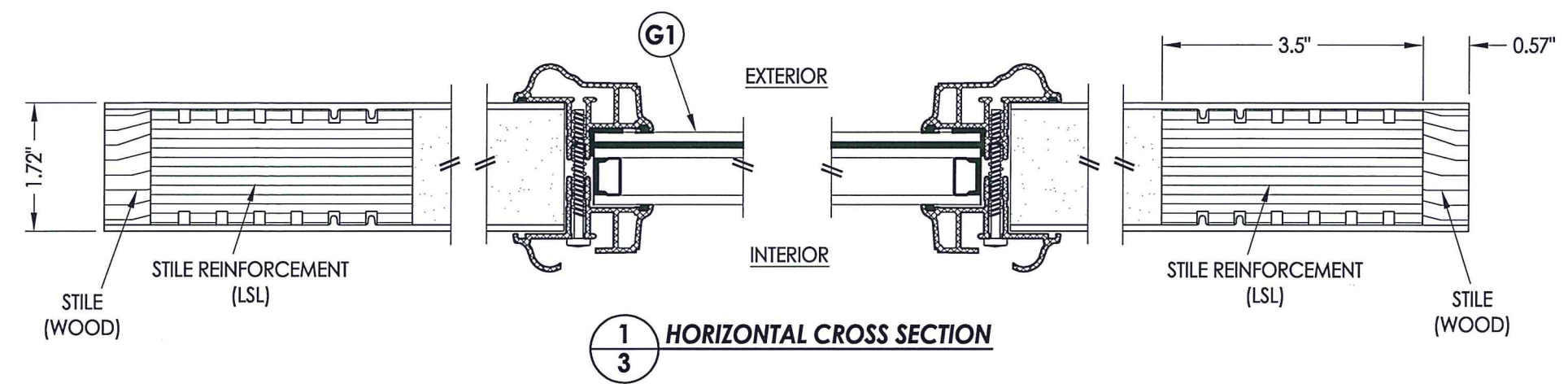

Documents Prepared By: Lyndon F. Schmidt, P.E.  
TEXAS P.E. #104123

**RW** BUILDING CONSULTANTS, INC.  
P.O. Box 230 Vairico FL, 33595  
Phone No.: 813.659.9197

TEXAS BOARD OF PROFESSIONAL ENGINEERS  
CERTIFICATE OF REGISTRATION # F-11852

PRODUCT: MASTERGRAIN FIBERGLASS DOOR

PART OR ASSEMBLY: DOOR PANEL DETAILS

NO.	DATE	DESCRIPTION	BY
1	3/05/20	UPDATE TO 2018 IBC/IRC CODE	LFS

REVISIONS

DATE: 9/04/18  
SCALE: N.T.S.  
DWG. BY: JK  
CHK. BY: LFS  
DRAWING NO.: TX-4893  
SHEET 3 OF 10

FIBERGLASS SIDELITE SKIN: 0.095" MIN. THK.  
FOAM CORE: POLYURETHANE - 1.9 PCF MIN.

**50** **SIDELITE PANEL**  
Mastergrain

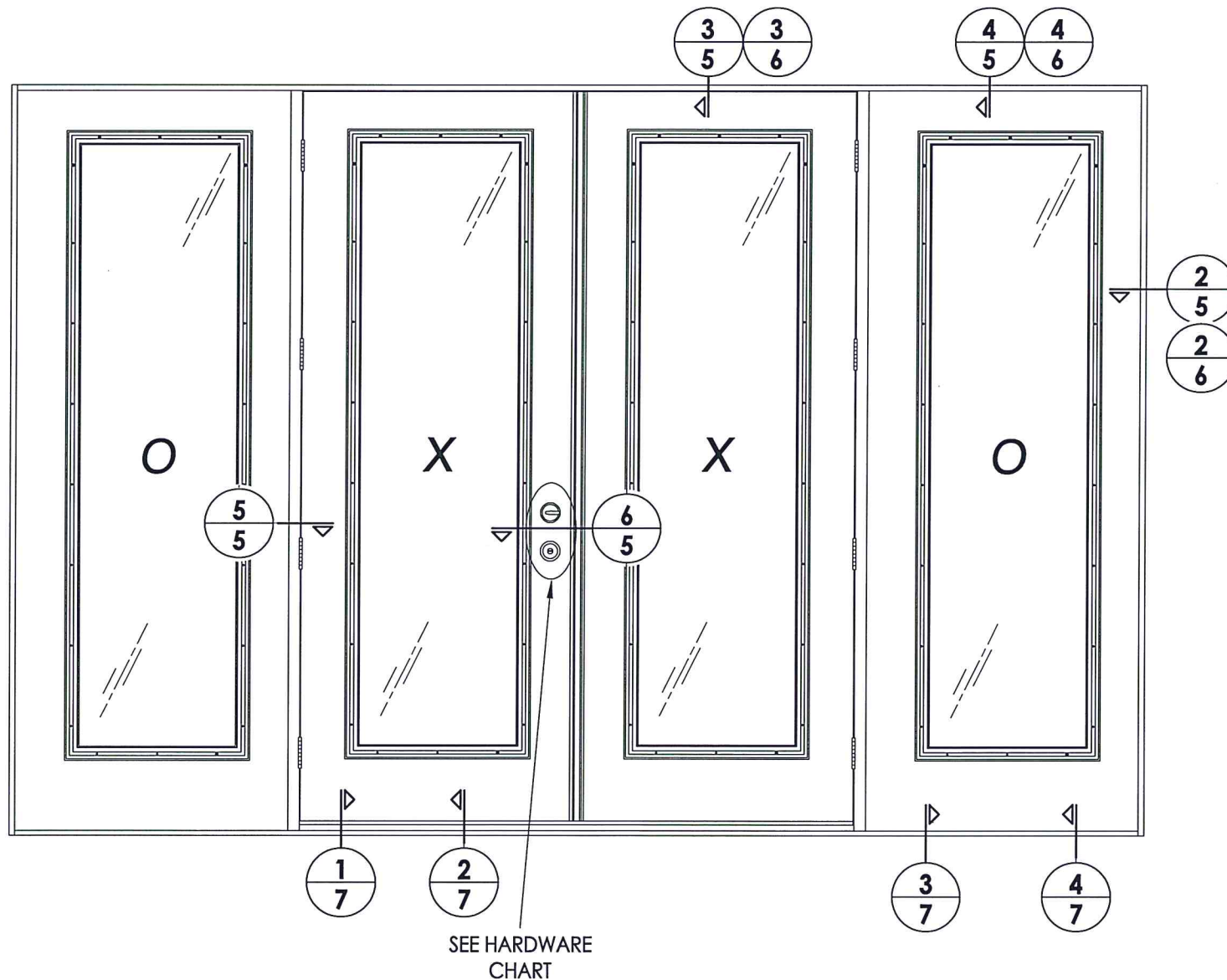
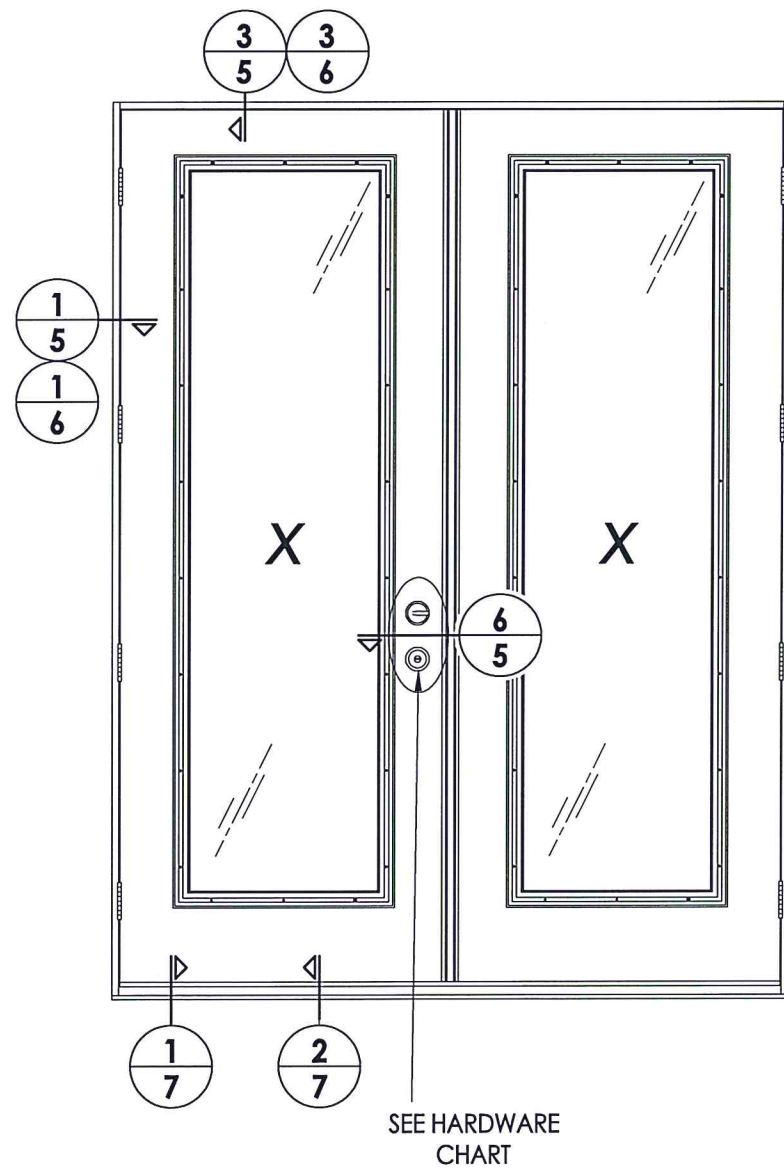

HARDWARE TABLE	
MANUFACTURER	MODEL
Kwikset	Knob: SIGNATURE SERIES
	Deadbolt: SIGNATURE SERIES (980)
Schlage	Knob: F51
	Deadbolt: B60N

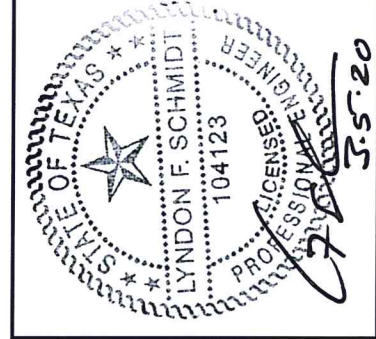

Documents Prepared By: Lyndon F. Schmidt, P.E.  
 TEXAS P.E. #104123

**RW** BUILDING CONSULTANTS, INC.  
 P.O. Box 230 Valrico FL 33595  
 Phone No.: 813.659.9197

TEXAS BOARD OF PROFESSIONAL ENGINEERS  
 CERTIFICATE OF REGISTRATION # F-11852

PRODUCT: MASTERGRAIN FIBERGLASS DOOR

PART OR ASSEMBLY: ELEVATIONS

NO.	DATE	DESCRIPTION	BY
1	3/05/20	UPDATE TO 2018 IBC/IRC CODE	LFS

DATE: 9/04/18  
 SCALE: N.T.S.  
 DWG. BY: JK  
 CHK. BY: LFS  
 DRAWING NO.: TX-4893  
 SHEET 4 OF 10

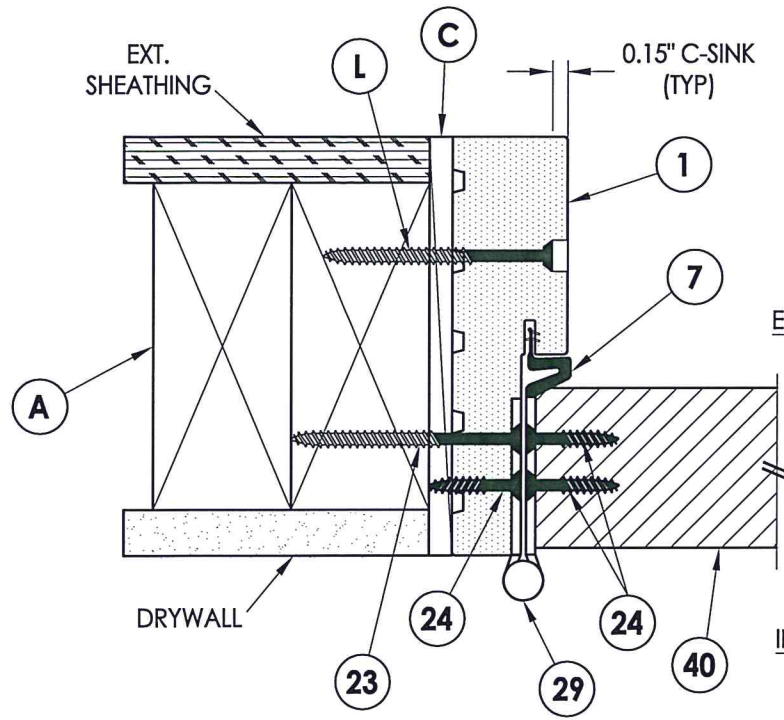

**1** **HORIZONTAL CROSS SECTION**  
**5** Shown w/ 2X Buck  
 Inswing shown (Outswing similar)

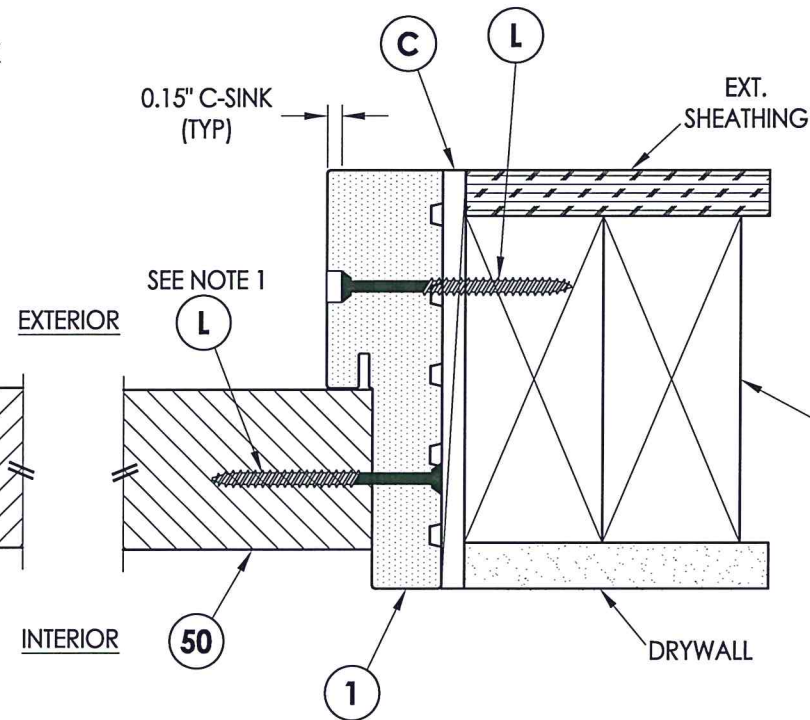

**2** **HORIZONTAL CROSS SECTION**  
**5** Shown w/ 2X Buck  
 Inswing shown (Outswing similar)

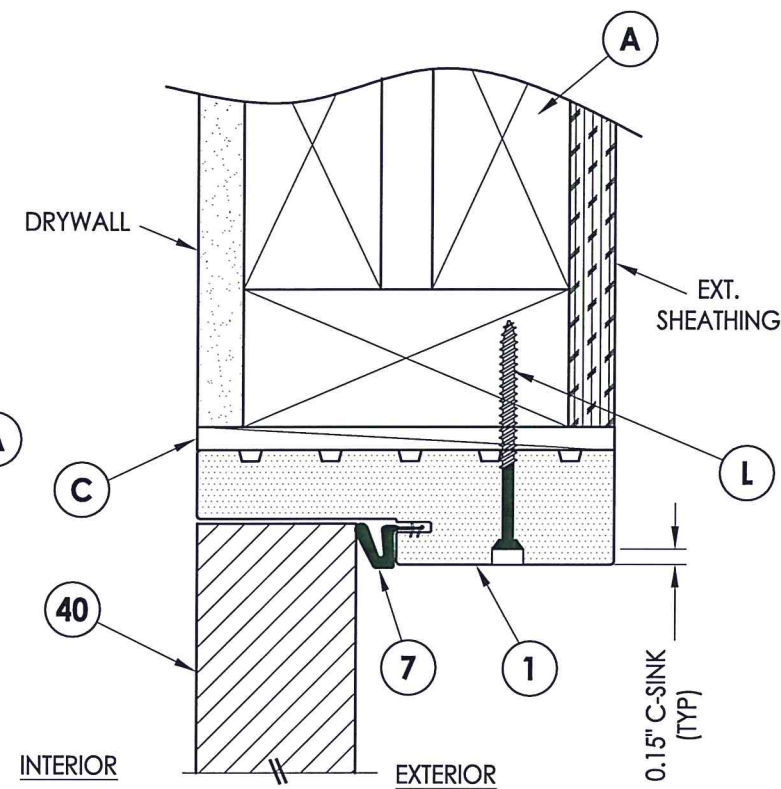

**3** **VERTICAL CROSS SECTION**  
**5** Shown w/ 2X Buck  
 Inswing shown (Outswing similar)

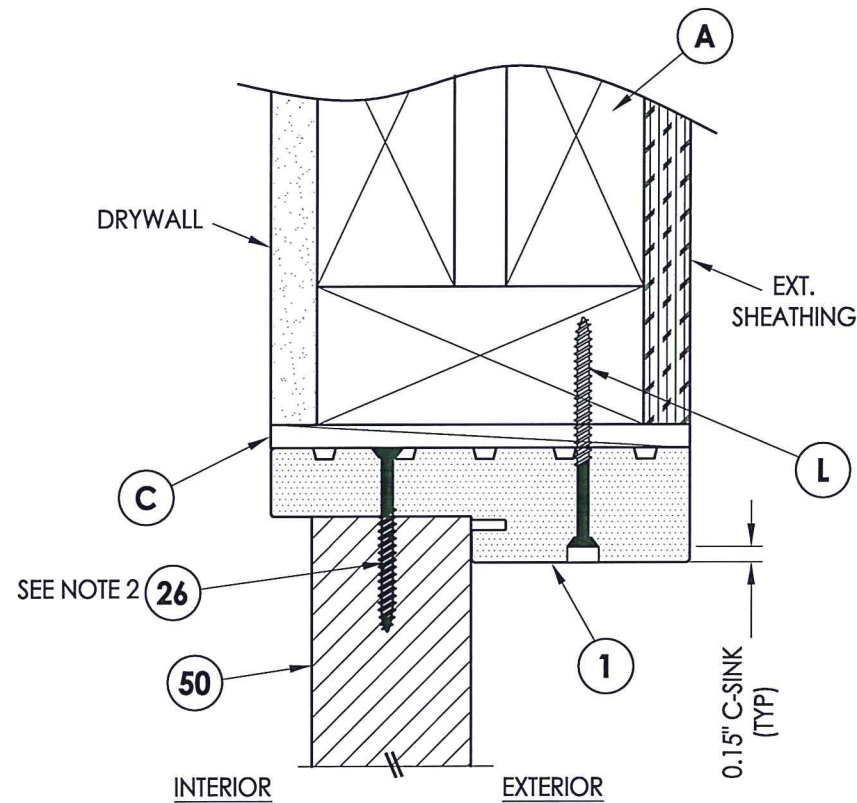

**4** **VERTICAL CROSS SECTION**  
**5** Shown w/ 2X Buck  
 Inswing shown (Outswing similar)

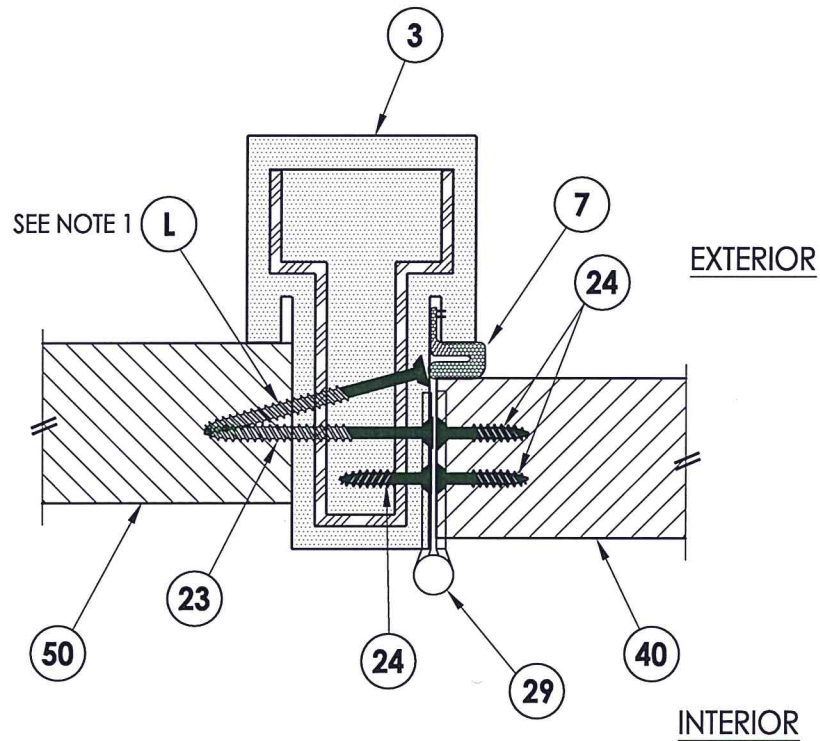

**5** **HORIZONTAL CROSS SECTION**  
**5** Inswing shown (Outswing similar)

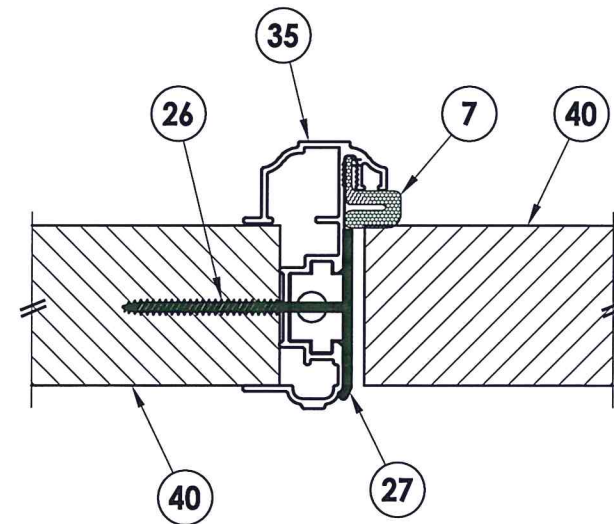

**6** **HORIZONTAL CROSS SECTION**  
**5** Inswing shown (Outswing similar)

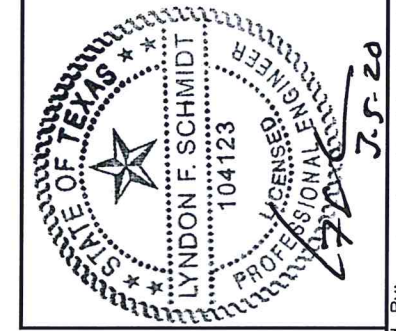

Documents Prepared By: Lyndon F. Schmidt, P.E.  
 TEXAS P.E. #104123

**RW** BUILDING CONSULTANTS, INC.  
 P.O. Box 230 Valrico FL 33595  
 Phone No.: 813.659.9197  
 TEXAS BOARD OF PROFESSIONAL ENGINEERS  
 CERTIFICATE OF REGISTRATION # F-11852

PRODUCT: MASTERGRAIN FIBERGLASS DOOR  
 PART OR ASSEMBLY: HORIZONTAL & VERTICAL CROSS SECTIONS (2X BUCK)

NO.	DATE	DESCRIPTION	BY
1	3/05/20	UPDATE TO 2018 IBC/IRC CODE	LFS

DATE: 9/04/18  
 SCALE: N.T.S.  
 DWG. BY: JK  
 CHK. BY: LFS  
 DRAWING NO.: TX-4893  
 SHEET 5 OF 10



NOTE:  
1. Item #L located 12" from each end (2 total).

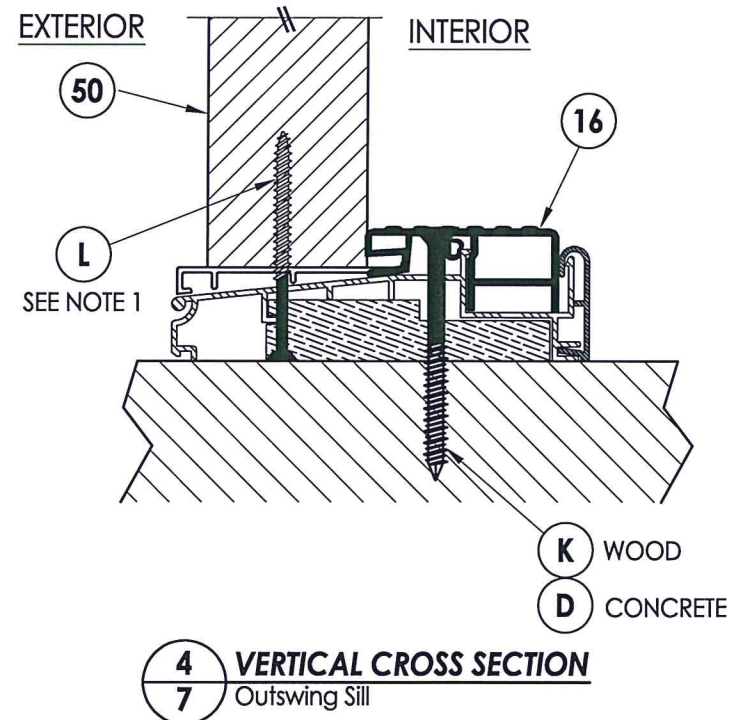
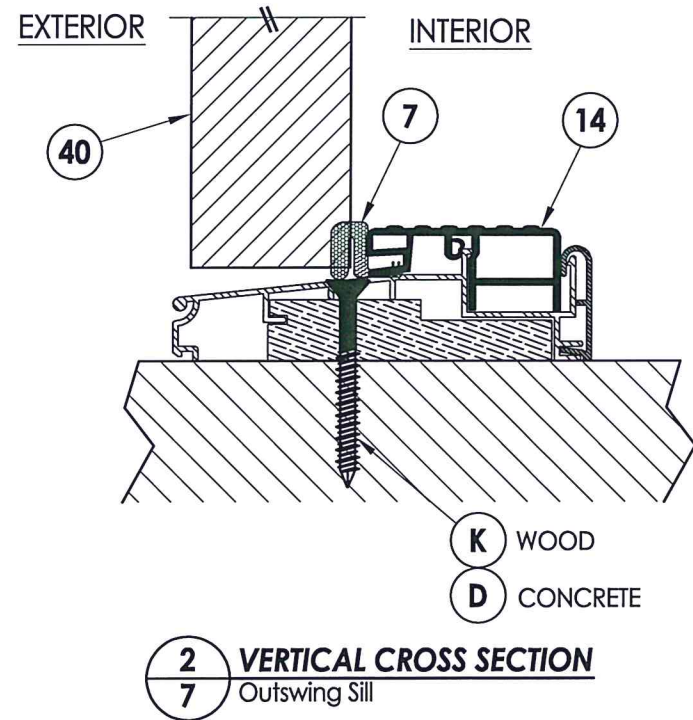
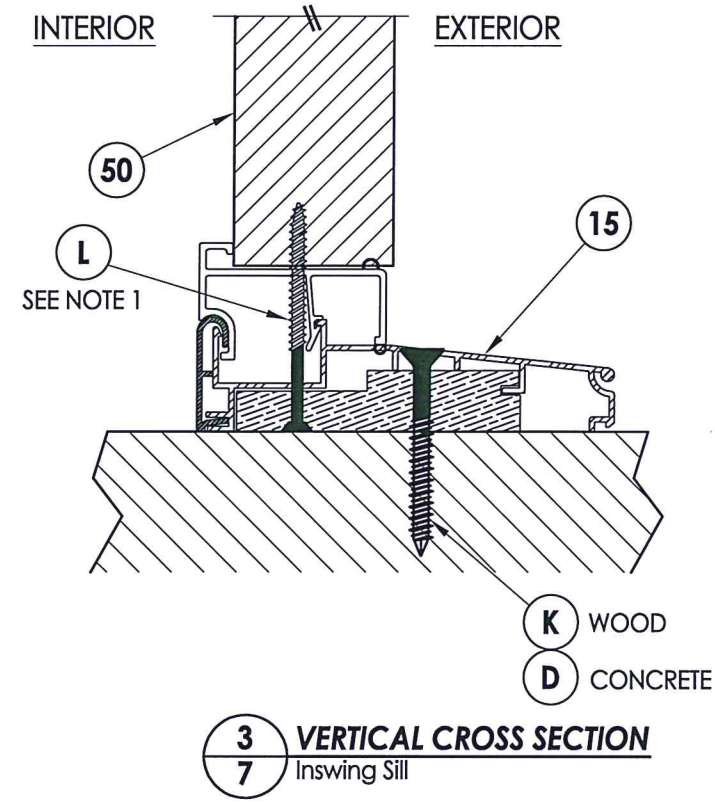
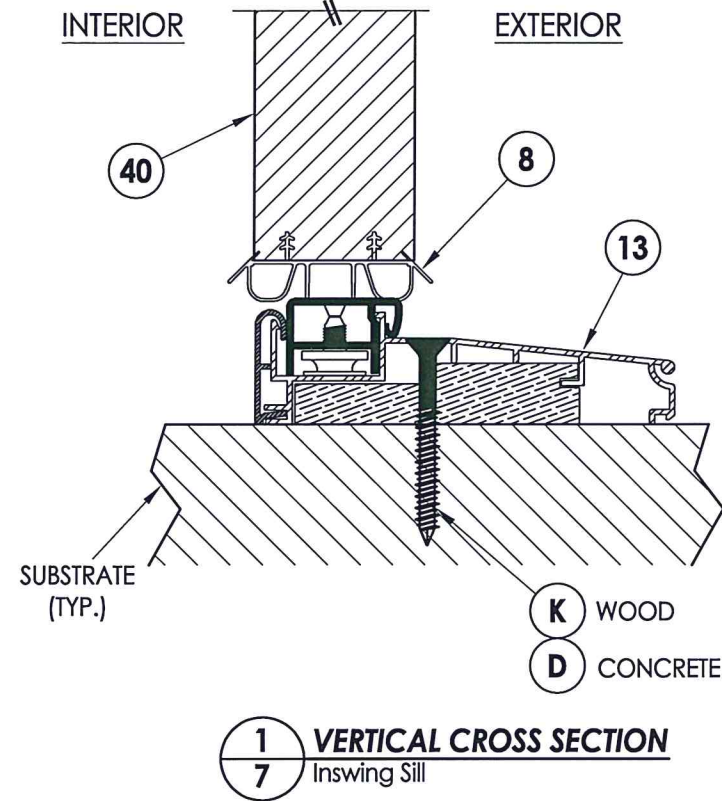

Documents Prepared By: Lyndon F. Schmidt, P.E.  
TEXAS P.E. #104123

**RW** BUILDING CONSULTANTS, INC.  
P.O. Box 230 Vairico FL. 33595  
Phone No.: 813.659.9197  
TEXAS BOARD OF PROFESSIONAL ENGINEERS  
CERTIFICATE OF REGISTRATION # F-11852

PRODUCT:	MASTERGRAIN FIBERGLASS DOOR
PART OR ASSEMBLY:	VERTICAL CROSS SECTIONS (THRESHOLDS)

NO.	DATE	DESCRIPTION	BY
1	3/05/20	UPDATE TO 2018 IBC/IRC CODE	LFS

DATE:	9/04/18
SCALE:	N.T.S.
DWG. BY:	JK
CHK. BY:	LFS
DRAWING NO.:	TX-4893
SHEET	7 OF 10

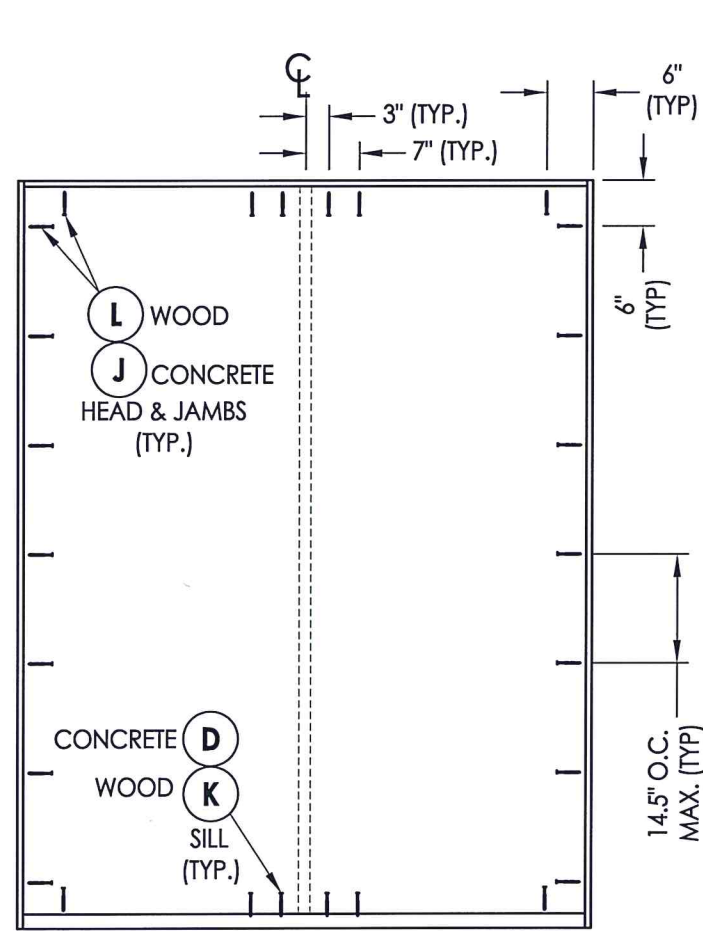

**XX**

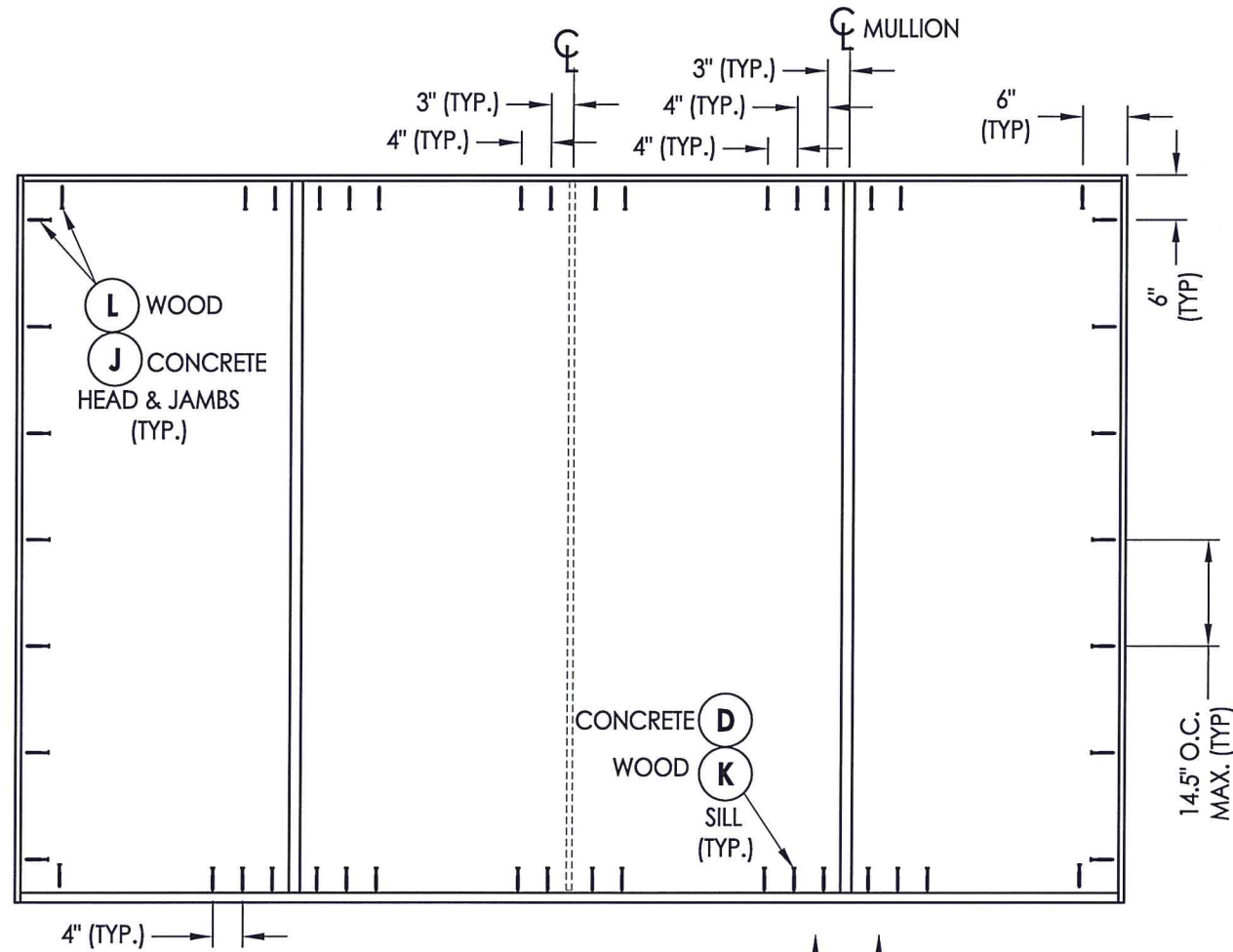

**OXXO**

**FRAME ANCHORING**

NOTE:  
1. ALL FRAME CORNERS SECURED WITH (3) #8 X 2-1/2" FH DEEP THREAD WOOD SCREWS @ HEAD & SILL.

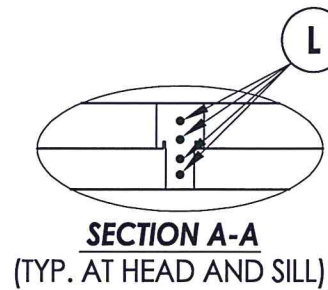

**SECTION A-A**  
(TYP. AT HEAD AND SILL)

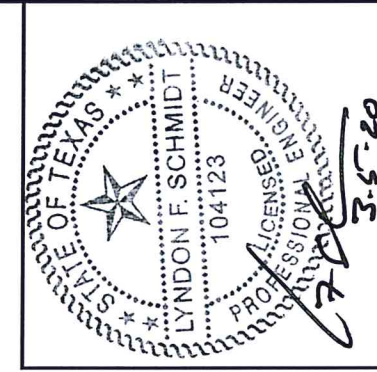

Documents Prepared By: Lyndon F. Schmidt, P.E.  
TEXAS P.E. #104123

**RW** BUILDING CONSULTANTS, INC.  
P.O. Box 230 Vairico FL 33595  
Phone No.: 813.659.9197  
TEXAS BOARD OF PROFESSIONAL ENGINEERS  
CERTIFICATE OF REGISTRATION # F-11852

PRODUCT:	MASTERGRAIN FIBERGLASS DOOR
PART OR ASSEMBLY:	FRAME ANCHORING & HARDWARE DETAILS

NO.	DATE	DESCRIPTION	BY
1	3/05/20	UPDATE TO 2018 IBC/IRC CODE	LFS

DATE:	9/04/18
SCALE:	N.T.S.
DWG. BY:	JK
CHK. BY:	LFS
DRAWING NO.:	TX-4893
SHEET	8 OF 10



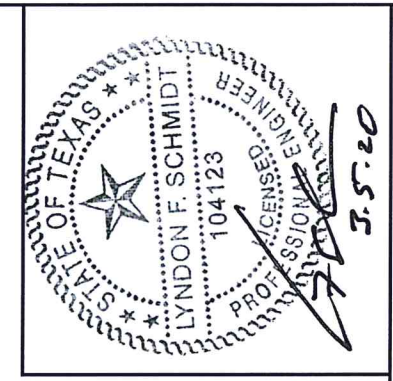
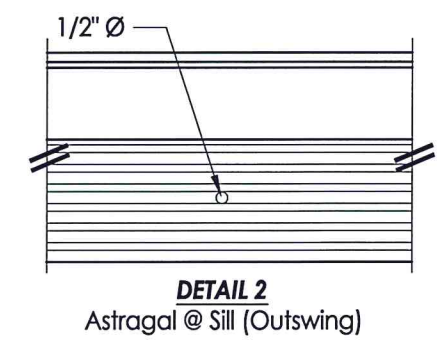
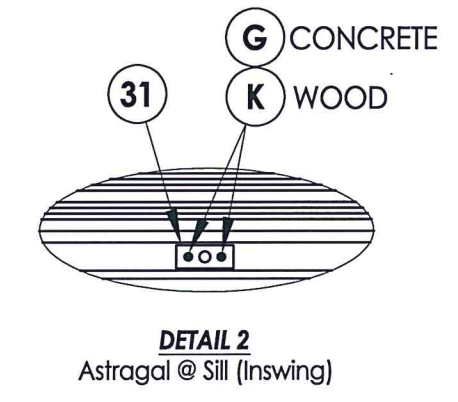
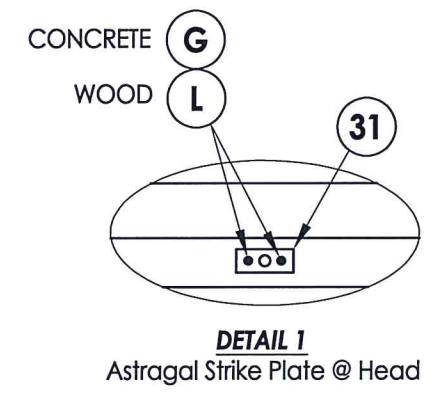
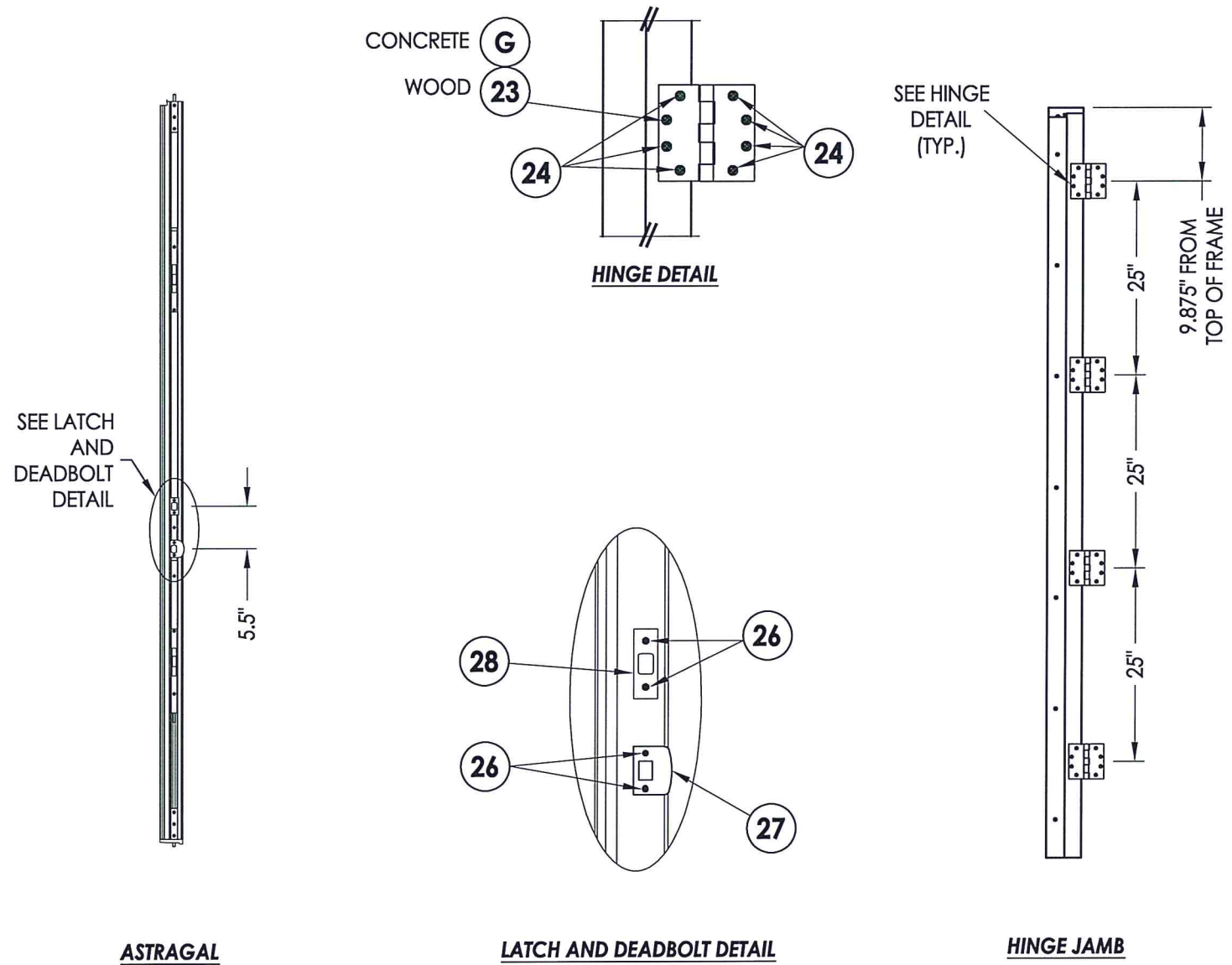

Documents Prepared By: Lyndon F. Schmidt, P.E.  
TEXAS P.E. #104123

**RW** BUILDING CONSULTANTS, INC.  
P.O. Box 230 Valrico FL 33595  
Phone No.: 813.659.9197

TEXAS BOARD OF PROFESSIONAL ENGINEERS  
CERTIFICATE OF REGISTRATION # F-11852

PRODUCT: MASTERGRAIN FIBERGLASS DOOR	
PART OR ASSEMBLY: HARDWARE DETAILS	
NO.	DATE
1	3/05/20
UPDATE TO 2018 IBC/IRC CODE	
LFS	BY
REVISIONS	
DATE: 9/04/18	
SCALE: N.T.S.	
DWG. BY: JK	
CHK. BY: LFS	
DRAWING NO.: TX-4893	
SHEET 9 OF 10	

**BILL OF MATERIALS**

ITEM #	DESCRIPTION	MATERIAL
A	1X BUCK (SG >= 0.42)	WOOD
B	2X BUCK (SG >= 0.42)	WOOD
C	1/4" MAX. SHIM SPACE	-
D	1/4" Ø PFH ELCO OR ITW CONCRETE SCREW (1-3/4" MIN. EMBEDMENT)	STEEL
E	MASONRY - 3,000 PSI MIN. CONCRETE CONFORMING TO ACI 301 OR HOLLOW BLOCK CONFORMING TO ASTM C90	CONCRETE
G	3/16" X 3-1/4" PFH ITW CONCRETE SCREW	STEEL
J	1/4" X 3-3/4" PFH ELCO OR ITW CONCRETE SCREW	STEEL
K	#10 PFH WS (1-3/4" MIN. EMBEDMENT)	STEEL
L	#10 X 2-1/2" PFH WOOD SCREW (1.15" MIN. EMBEDMENT)	STEEL
1	COMPOSITE JAMB	COMP
3	MULLION	ALUM/COMP
7	WEATHERSTRIP	FOAM
8	SWEEP	VINYL
13	INSWING ADJUSTABLE THRESHOLD	ALUM/COMP
14	OUTSWING BUMP THRESHOLD	ALUM/COMP
15	INSWING THRESHOLD (w/ SIDELITE ADAPTER)	ALUM/COMP
16	OUTSWING THRESHOLD (w/ SIDELITE ADAPTER)	ALUM/COMP
23	#12 X 2-1/2" PFH WOOD SCREW	STEEL
24	#12 x 1" PFH WOOD SCREW	STEEL
26	#10 X 2" PFH WOOD SCREW	STEEL
27	LATCH STRIKE PLATE	STEEL
28	DEADBOLT STRIKE PLATE	STEEL
29	4.5" X 4.5" HINGE	STEEL
31	ASTRAGAL STRIKE PLATE	STEEL
35	ASTRAGAL	ALUM
40	DOOR PANEL	-
50	SIDELITE PANEL	-

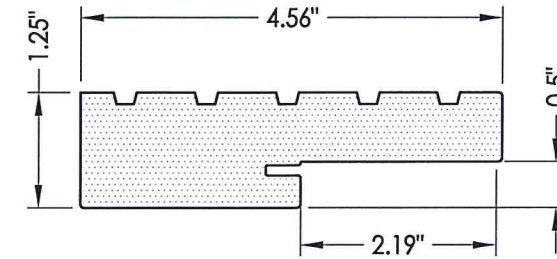

**1 COMPOSITE JAMB**  
WORLDWIDE

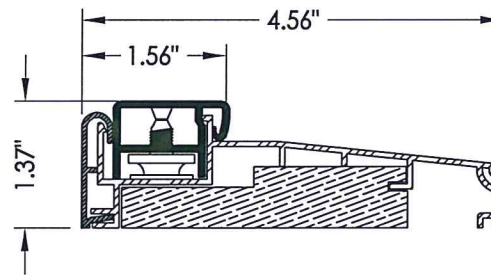

**13 INSWING THRESHOLD**  
WORLDWIDE

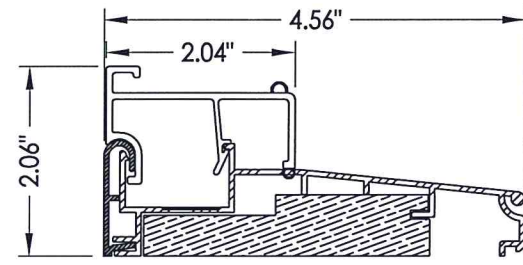

**15 INSWING THRESHOLD w/ SIDELITE ADAPTER**  
WORLDWIDE

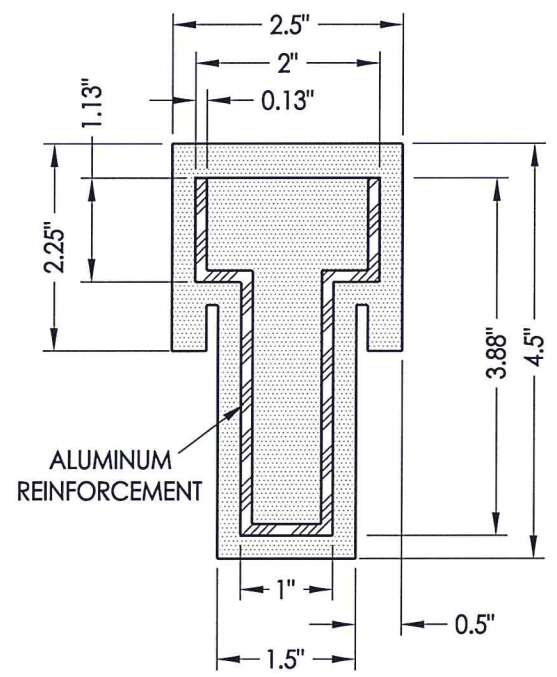

**3 COMPOSITE MULLION**  
WORLDWIDE

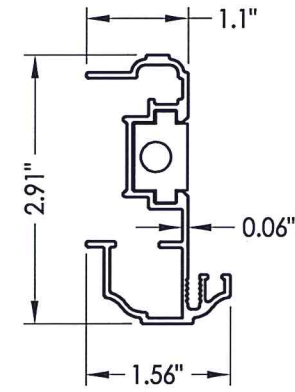

**35 ASTRAGAL**  
WORLDWIDE

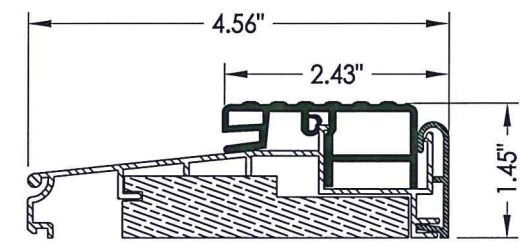

**14 OUTSWING THRESHOLD**  
WORLDWIDE

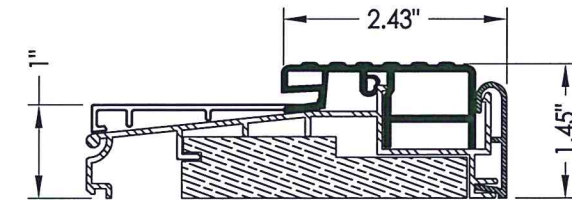

**16 OUTSWING THRESHOLD w/ SIDELITE ADAPTER**  
WORLDWIDE

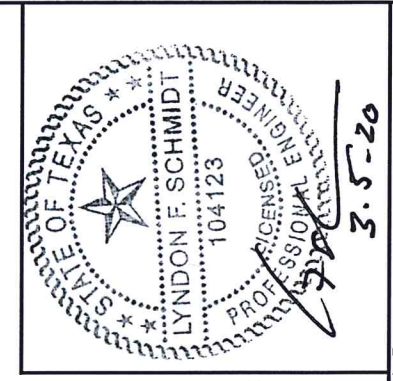

Documents Prepared By: Lyndon F. Schmidt, P.E.  
TEXAS P.E. #104123

**RW** BUILDING CONSULTANTS, INC.  
P.O. Box 230 Vairico FL, 33595  
Phone No.: 813.659.9197

TEXAS BOARD OF PROFESSIONAL ENGINEERS  
CERTIFICATE OF REGISTRATION # F-11852

PRODUCT: MASTERGRAIN FIBERGLASS DOOR

PART OR ASSEMBLY: BILL OF MATERIALS & COMPONENTS

NO.	DATE	DESCRIPTION	LFS	BY
1	3/05/20	UPDATE TO 2018 IBC/IRC CODE	LFS	BY

REVISIONS

DATE: 9/04/18  
SCALE: N.T.S.  
DWG. BY: JK  
CHK. BY: LFS  
DRAWING NO.: TX-4893  
SHEET 10 of 10

**CONCRETE ANCHOR NOTES:**

- Concrete anchor locations at the comers may be adjusted to maintain the min. edge distance to mortar joints.
- Concrete anchor locations noted as "MAX. ON CENTER" must be adjusted to maintain the min. edge distance to mortar joints, additional concrete anchors may be required to ensure the "MAX. ON CENTER" dimension are not exceeded.
- Concrete anchor table:

ANCHOR TYPE	ANCHOR SIZE	MIN. EMBEDMENT	MIN. CLEARANCE TO MASONRY EDGE	MIN. CLEARANCE TO ADJACENT ANCHOR
ITW TAPCON®	1/4"	1-1/4"	2"	4"
ELCO ULTRACON®	1/4"	1-1/4"	1"	4"
ITW TAPCON®	3/16"	1-1/4"	3"	1-1/2"

**WOOD SCREW INSTALLATION NOTES:**

- Maintain a minimum 5/8" edge distance, 1" end distance, & 1" o.c. spacing of wood screws to prevent the splitting of wood.