



A SENNECA COMPANY

HURRICANE SERIES FIBERGLASS DOUBLE DOOR OUTSWING "NON-IMPACT"

EVALUATED FOR USE IN THE STATE OF TEXAS

DR-980

The Fiberglass Door system described herein complies with the 2018 International Residential Code (IRC), Sections R301 & R609 and the 2018 International Building Code (IBC), Sections 1404.13, 1609, 1709.5, 2403 and 2404 subject to the following conditions:

1. Anchors shall be as listed and spaced as shown in the details. Anchor embedment to base material shall be beyond wall dressing or stucco.
2. When used in areas requiring wind-borne debris protection this product is required to be protected with an impact resistant covering that complies with Section R301.2.1.2 of the IRC and Section 1609.1.2 of the IBC.
3. Allowable design pressure requirements must be equal to or less than the design pressure rating shown in the design pressure chart, sheet 1 of this drawing.
4. Conditions not covered by this drawing are subject to further engineering analysis.

TABLE OF CONTENTS

SHEET #	DESCRIPTION
1	Typical elevations, design pressures & general notes
2	Door panel details
3	Horizontal cross sections
4	Vertical cross sections
5	Frame anchoring
6	Frame anchoring & hardware details
7	Bill of materials & components

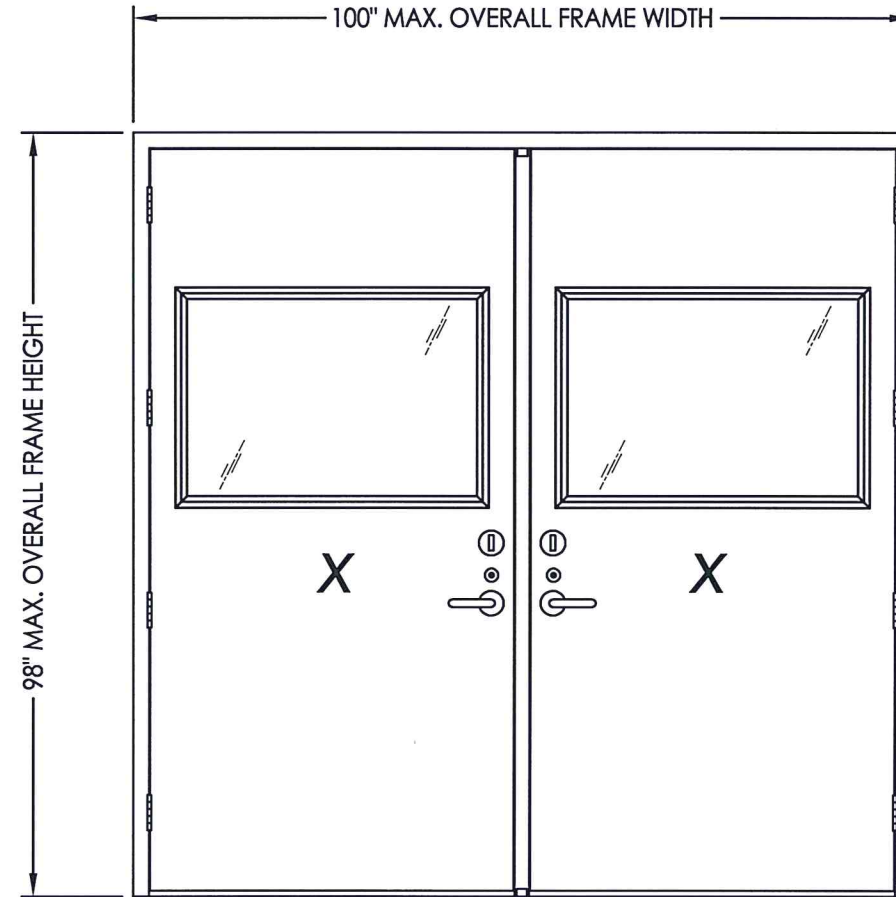

GLAZED PANELS SHOWN
(OPAQUE SIMILAR)

MAX FRAME DIMENSION	DOOR TYPE	DESIGN PRESSURE (PSF) OUTSWING	
		POSITIVE	NEGATIVE
100" x 98"	OPAQUE	+45.0	-45.0
100" x 98"	GLAZED	+45.0	-45.0



Documents Prepared By: Lyndon F. Schmidt, P.E.
TEXAS P.E. #104123

RW BUILDING CONSULTANTS, INC.
P.O. Box 230 Valrico FL, 33595
Phone No.: 813.659.9197

CERTIFICATE OF REGISTRATION # F-11852

PRODUCT:	FIBERGLASS DOOR	
PART OR ASSEMBLY:	TYPICAL ELEVATION, DESIGN PRESSURES & GENERAL NOTES	
NO.	DATE	BY
1	1/19/22	LFS
REVISIONS		
DATE:	5/14/18	
SCALE:	N.T.S.	
DWG. BY:	JK	
CHK. BY:	LFS	
DRAWING NO.:	TX-4835	
SHEET	1 OF 7	

Z:\Clients\Senneca\B - Texas Dept of Ins\Chem-Pruf\Fiberglass Door - Non-Impact\Drawings\TX-4834.35.36 REV.dwg

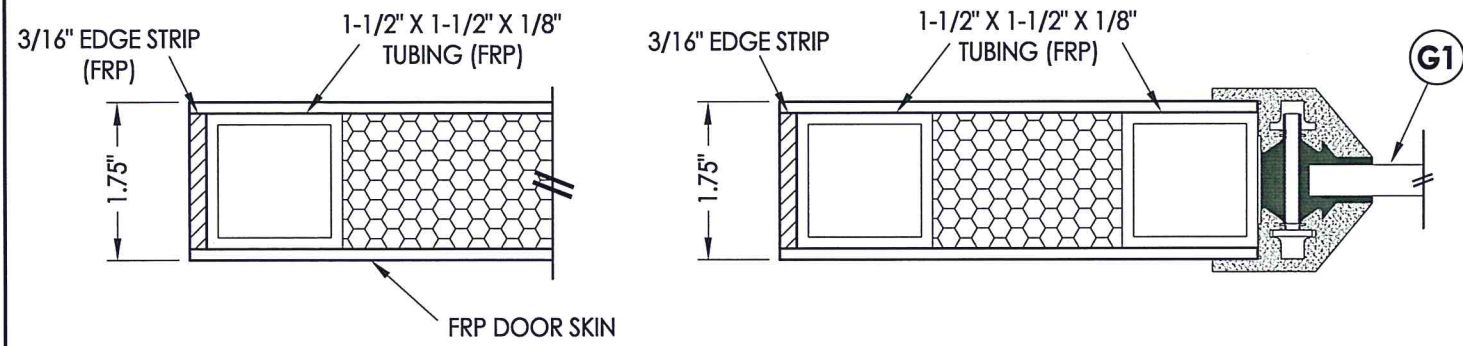

1
2 HORIZONTAL CROSS SECTION

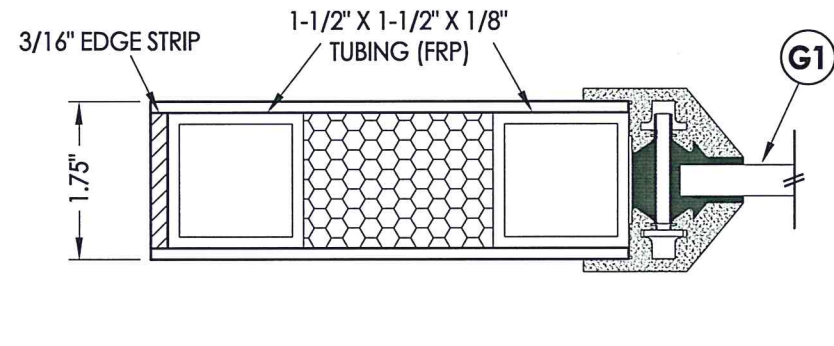

2
2 HORIZONTAL CROSS SECTION

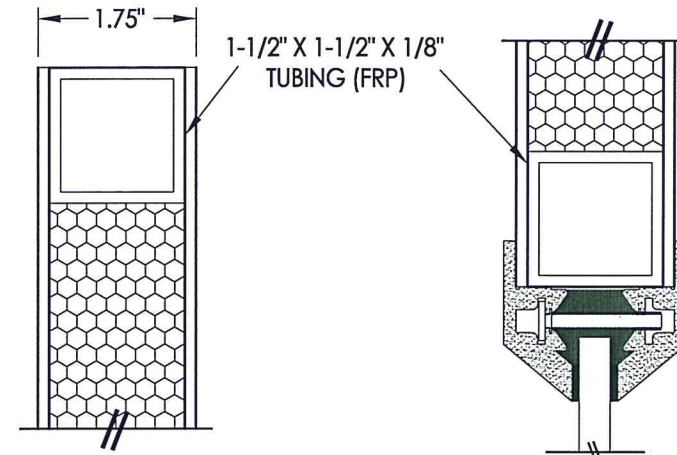

3
2 VERTICAL CROSS SECTION

EXTERIOR INTERIOR

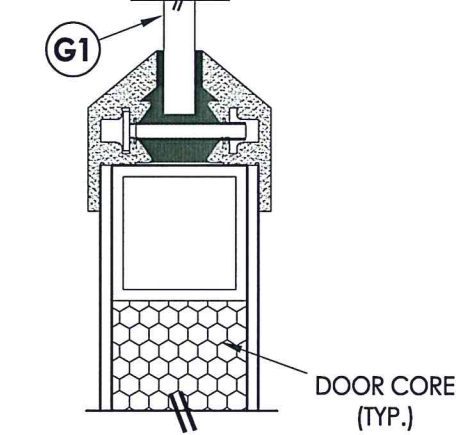

5
2 VERTICAL CROSS SECTION

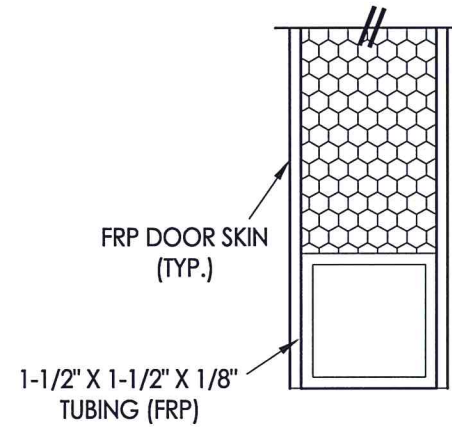

4
2 VERTICAL CROSS SECTION

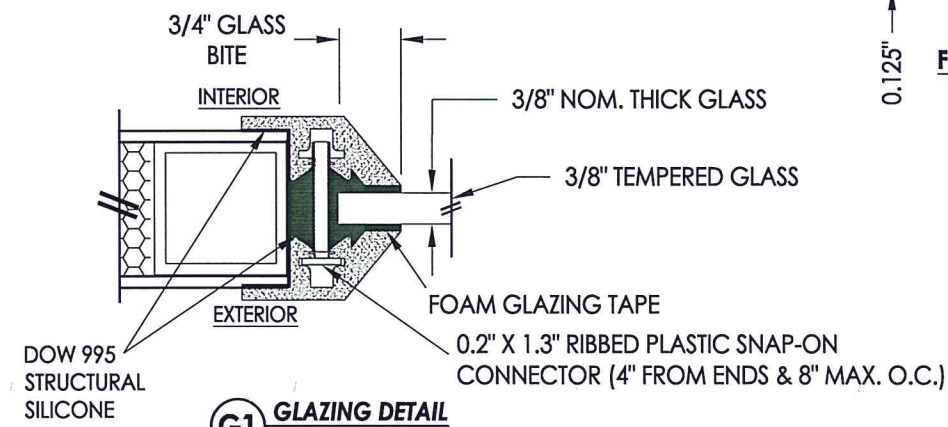
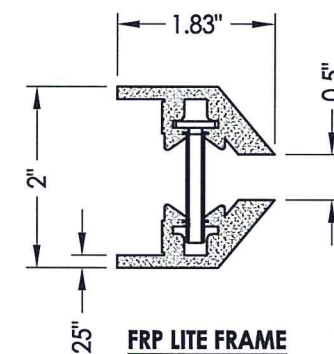

G1 GLAZING DETAIL

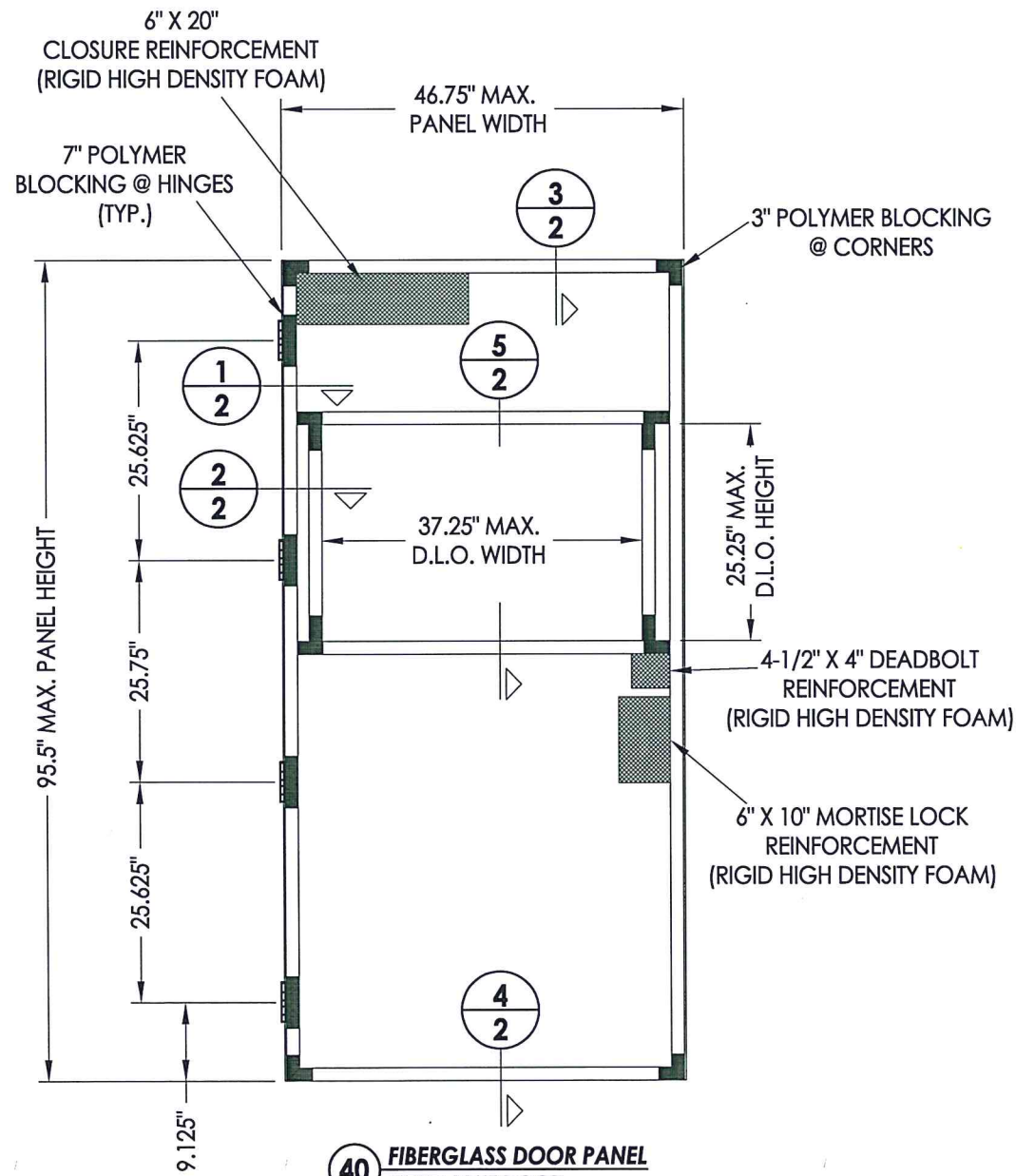

40 FIBERGLASS DOOR PANEL
CHEM-PRUF DOOR

DOOR SKIN: 0.125" MIN. THICKNESS
DOOR CORE: POLYPROPYLENE HONEYCOMB

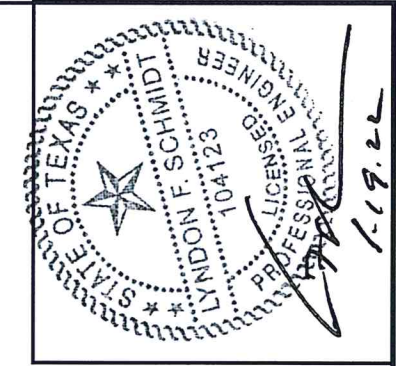

Documents Prepared By: Lyndon F. Schmidt, P.E.
TEXAS P.E. #104123

RW BUILDING CONSULTANTS, INC.
P.O. Box 230 Vairico FL 33595
Phone No.: 813.659.9197

CERTIFICATE OF REGISTRATION # F-11852

PRODUCT:	FIBERGLASS DOOR
PART OR ASSEMBLY:	DOOR PANEL DETAILS

NO.	DATE	BY
1	1/19/22	LFS
UPDATE TO 2018 IBC/IRC		
REVISIONS		

DATE: 5/14/18

SCALE: N.T.S.

DWG. BY: JK

CHK. BY: LFS

DRAWING NO.:

TX-4835

SHEET 2 OF 7

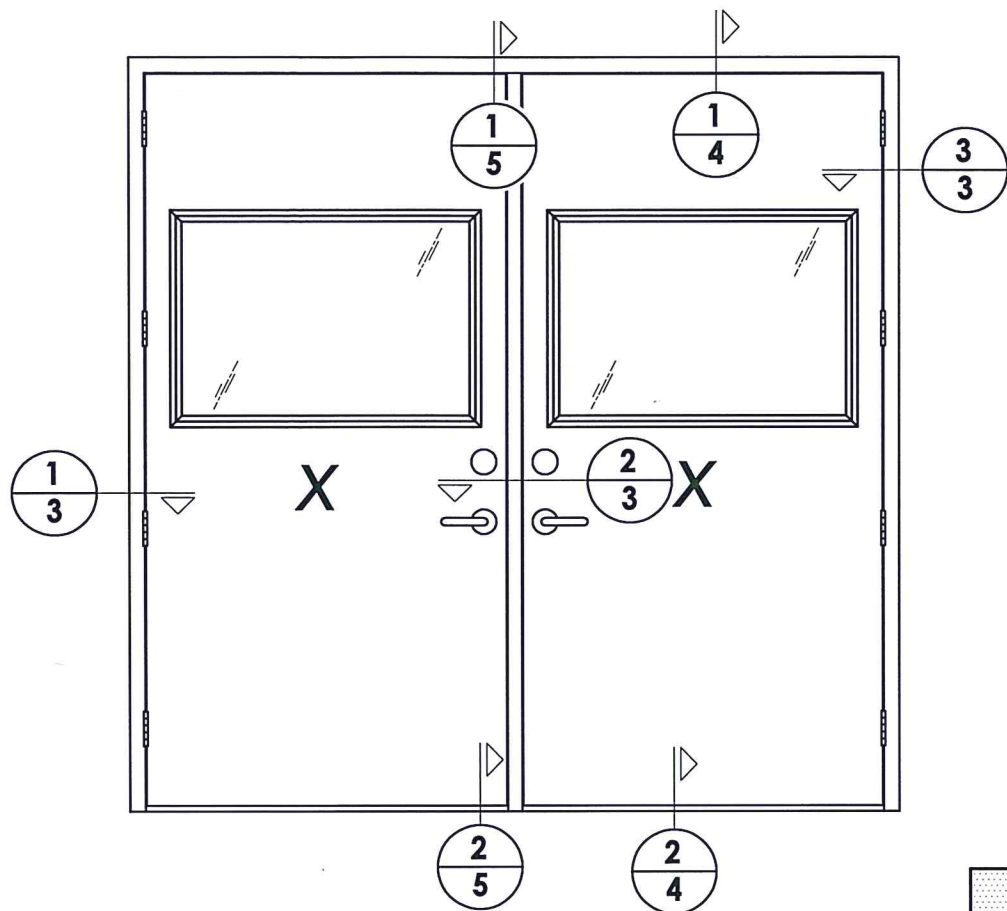

- NOTES:
 1. ALL FRP REINFORCEMENTS/ANCHOR BLOCKS ARE SECURED TO THE FRAME WITH LORD 7542A/B URETHANE ADHESIVE.
 2. FRAME REINFORCEMENTS SHOWN IN SECTION 3/3 ARE REQUIRED AT EACH ANCHOR LOCATION.

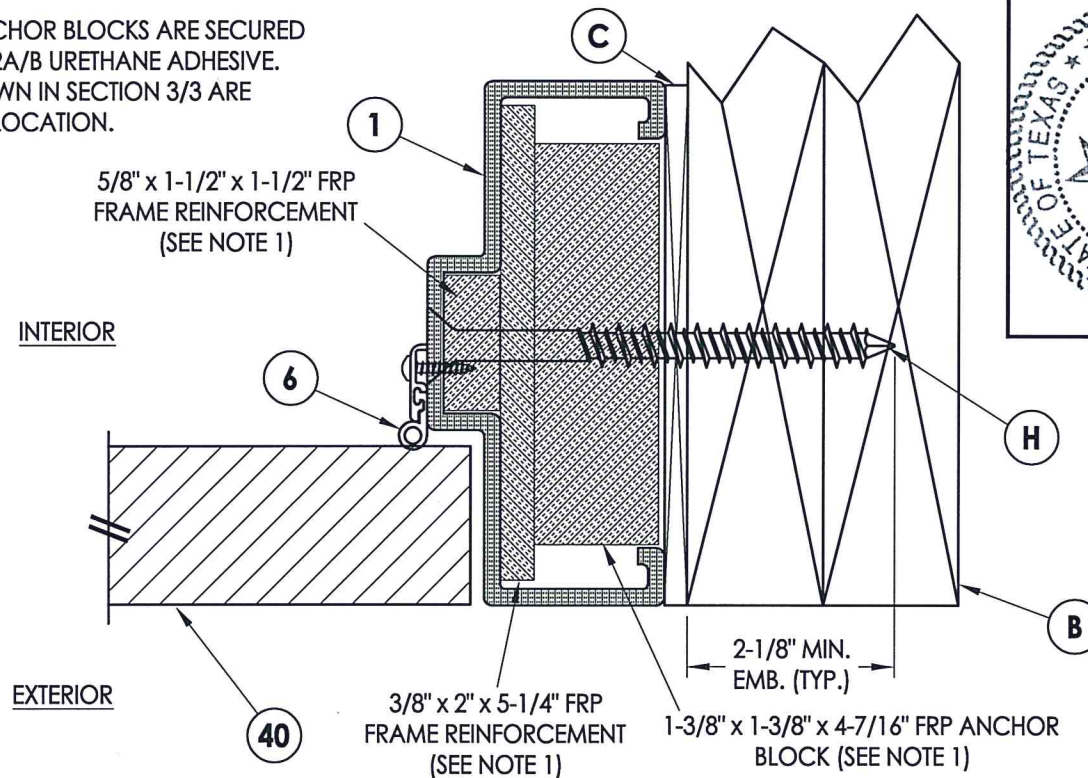

3 HORIZONTAL CROSS SECTION
 3 Outswing configuration

HARDWARE CHART	
MANUFACTURER	MODEL
SCHLAGE	MORTISE LOCK: L 9000 SERIES
SARGENT	DEADBOLT: 480 SERIES

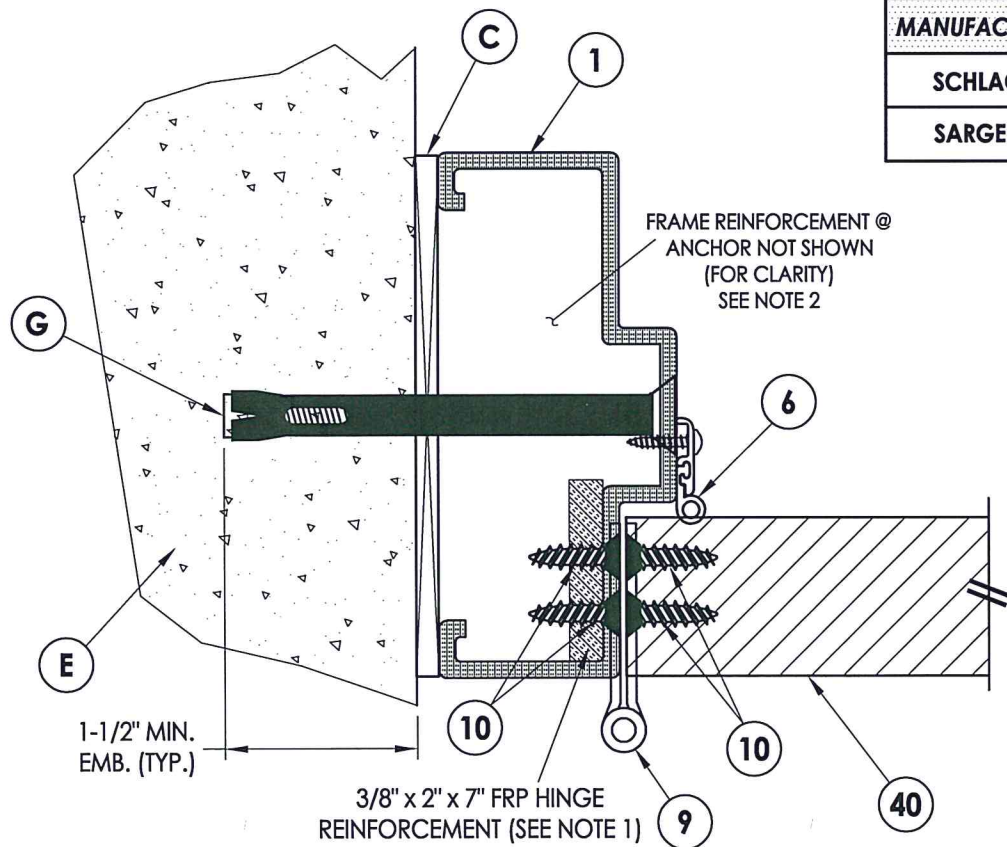

1 HORIZONTAL CROSS SECTION
 3 Outswing configuration

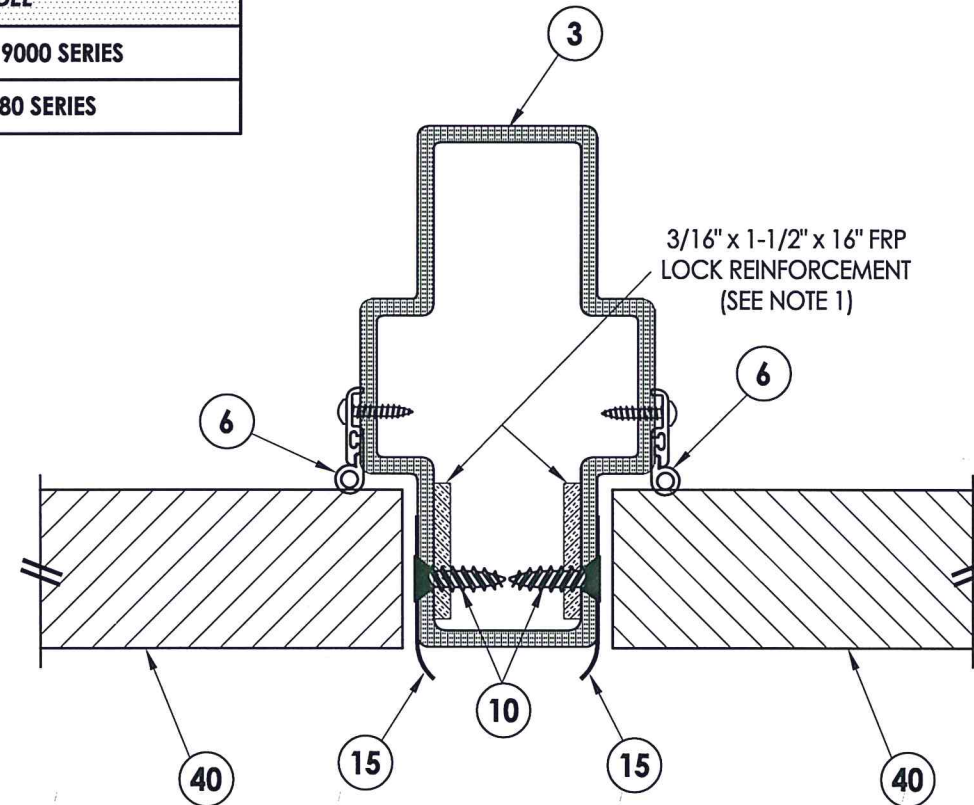

2 HORIZONTAL CROSS SECTION
 3 Outswing configuration

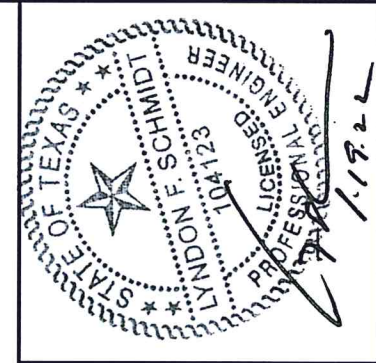

Documents Prepared By: Lyndon F. Schmidt, P.E.
 TEXAS P.E. #104123
RW BUILDING CONSULTANTS, INC.
 P.O. Box 230 Valrico FL 33595
 Phone No.: 813.659.9197
 CERTIFICATE OF REGISTRATION # F-11852

PRODUCT:	FIBERGLASS DOOR	
PART OR ASSEMBLY:	HORIZONTAL CROSS SECTIONS	
NO.	DATE	BY
1	1/19/22	LFS
UPDATE TO 2018 IBC/IRC		
REVISIONS		
DATE:	5/14/18	
SCALE:	N.T.S.	
DWG. BY:	JK	
CHK. BY:	LFS	
DRAWING NO.:	TX-4835	
SHEET	3	OF 7

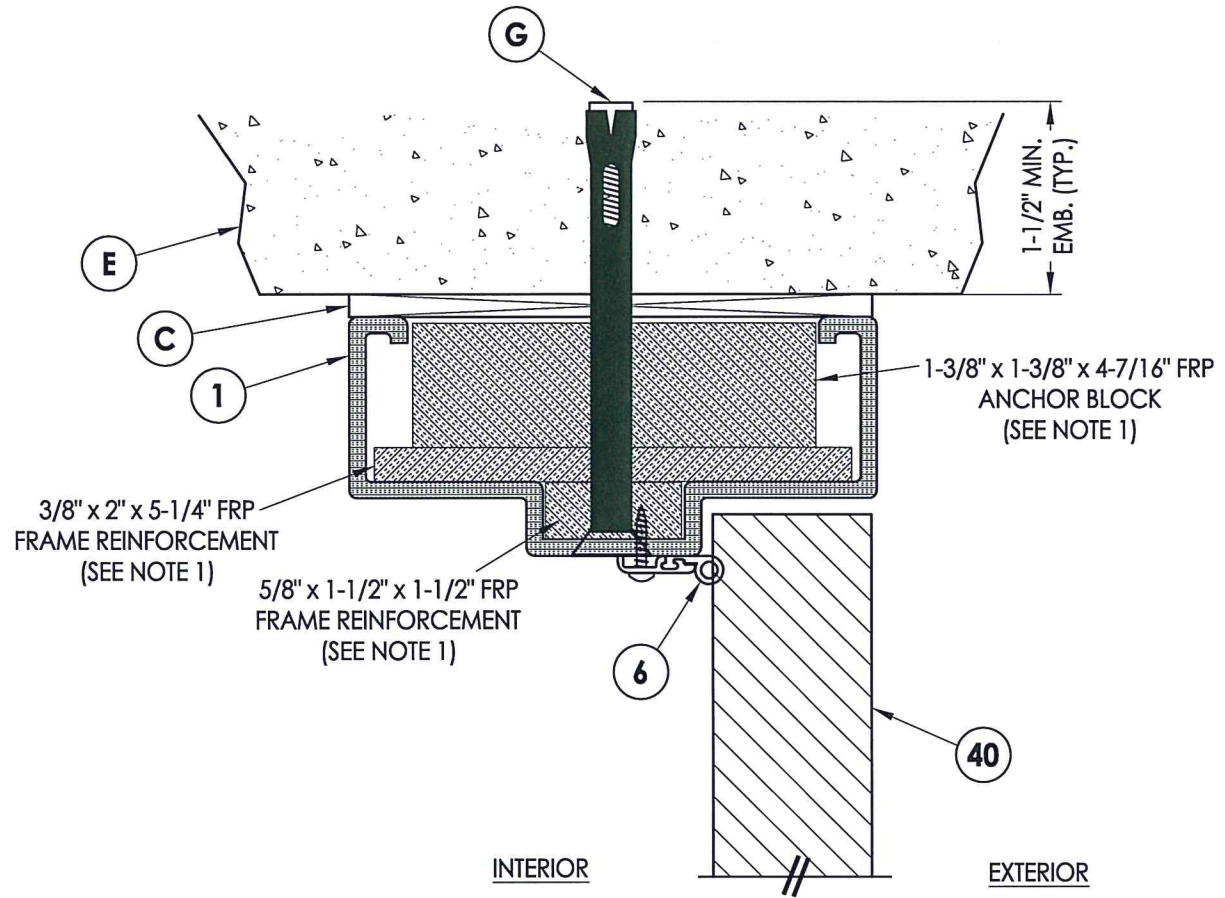

1 VERTICAL CROSS SECTION
4 Outswing configuration

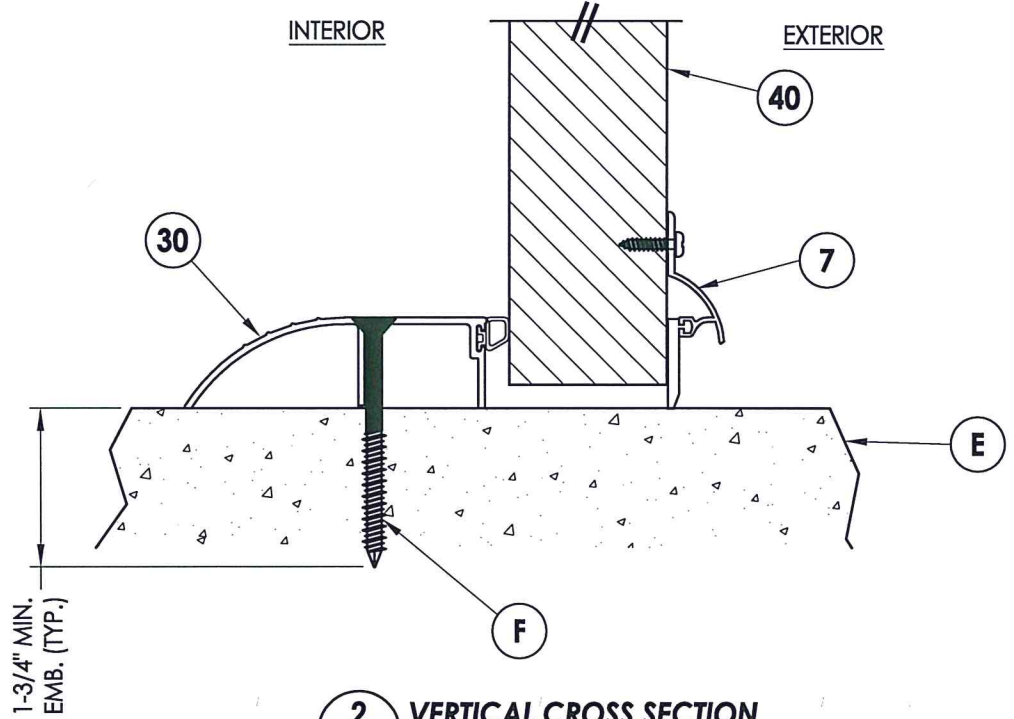

2 VERTICAL CROSS SECTION
4 Outswing Sill

NOTES:
 1. ALL FRP REINFORCEMENTS/ANCHOR BLOCKS ARE SECURED TO THE FRAME WITH LORD 7542A/B URETHANE ADHESIVE.

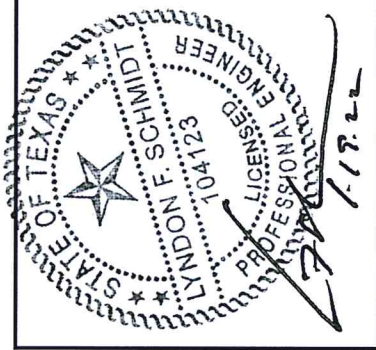

Documents Prepared By: Lyndon F. Schmidt, P.E.
 TEXAS P.E. #104123

RW BUILDING CONSULTANTS, INC.
 P.O. Box 230 Valrico FL 33595
 Phone No.: 813.659.9197

CERTIFICATE OF REGISTRATION # F-11852

PRODUCT: FIBERGLASS DOOR
 PART OR ASSEMBLY: HORIZONTAL CROSS SECTIONS

NO.	DATE	BY	REVISIONS
1	1/19/22	LFS	UPDATE TO 2018 IBC/IRC

DATE: 5/14/18
 SCALE: N.T.S.
 DWG. BY: JK
 CHK. BY: LFS
 DRAWING NO.: TX-4835
 SHEET 4 OF 7

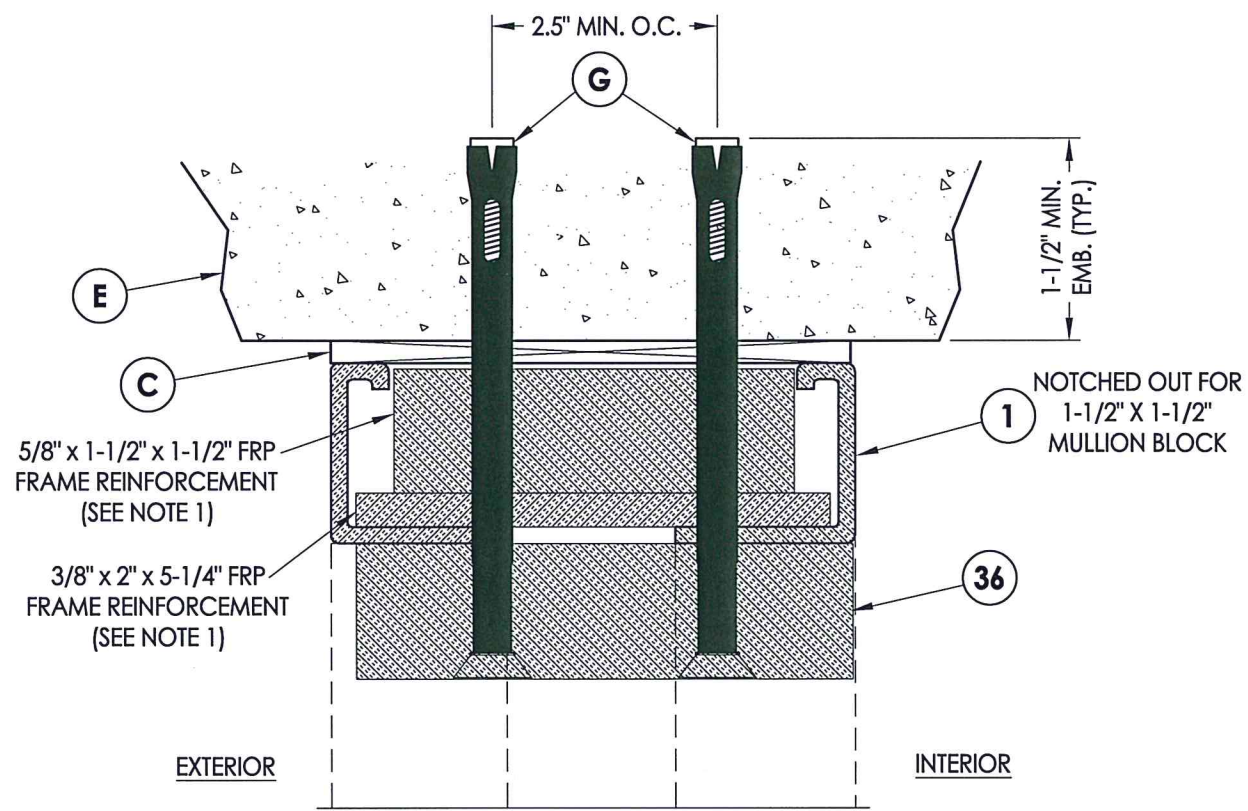

1
5 **VERTICAL CROSS SECTION**
@ Removable Mullion

NOTES:
1. ALL FRP REINFORCEMENTS/ANCHOR BLOCKS ARE SECURED TO THE FRAME WITH LORD 7542A/B ADHESIVE.

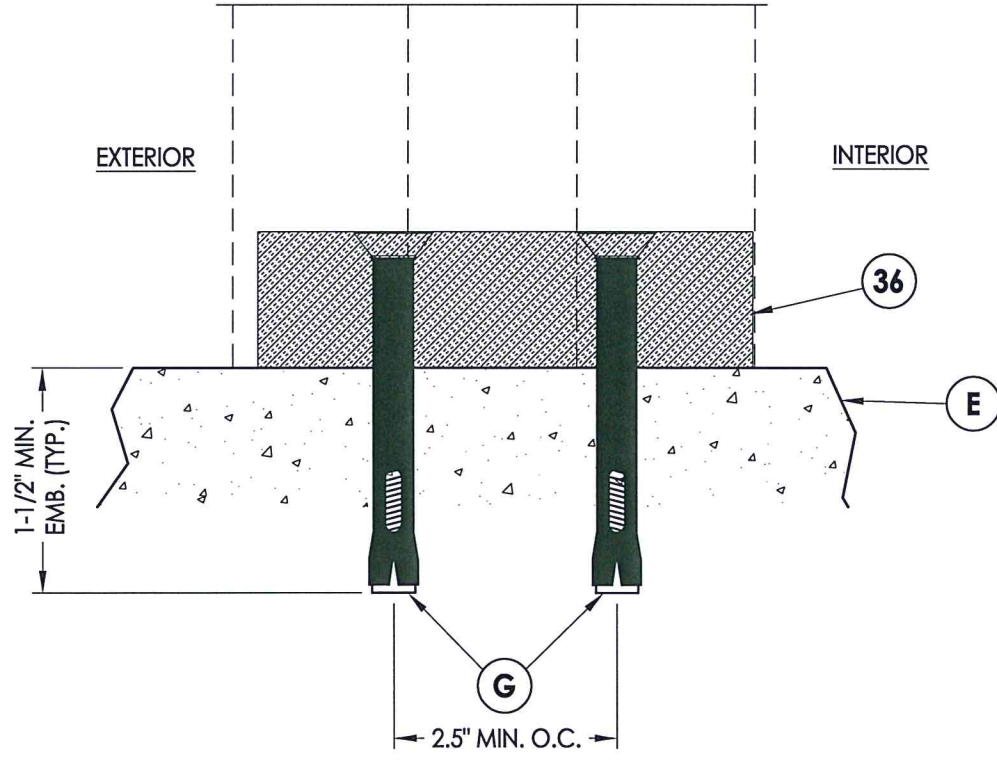

2
5 **VERTICAL CROSS SECTION**
@ Removable Mullion

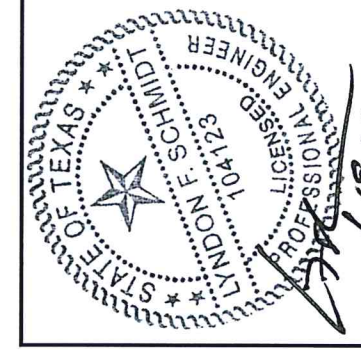
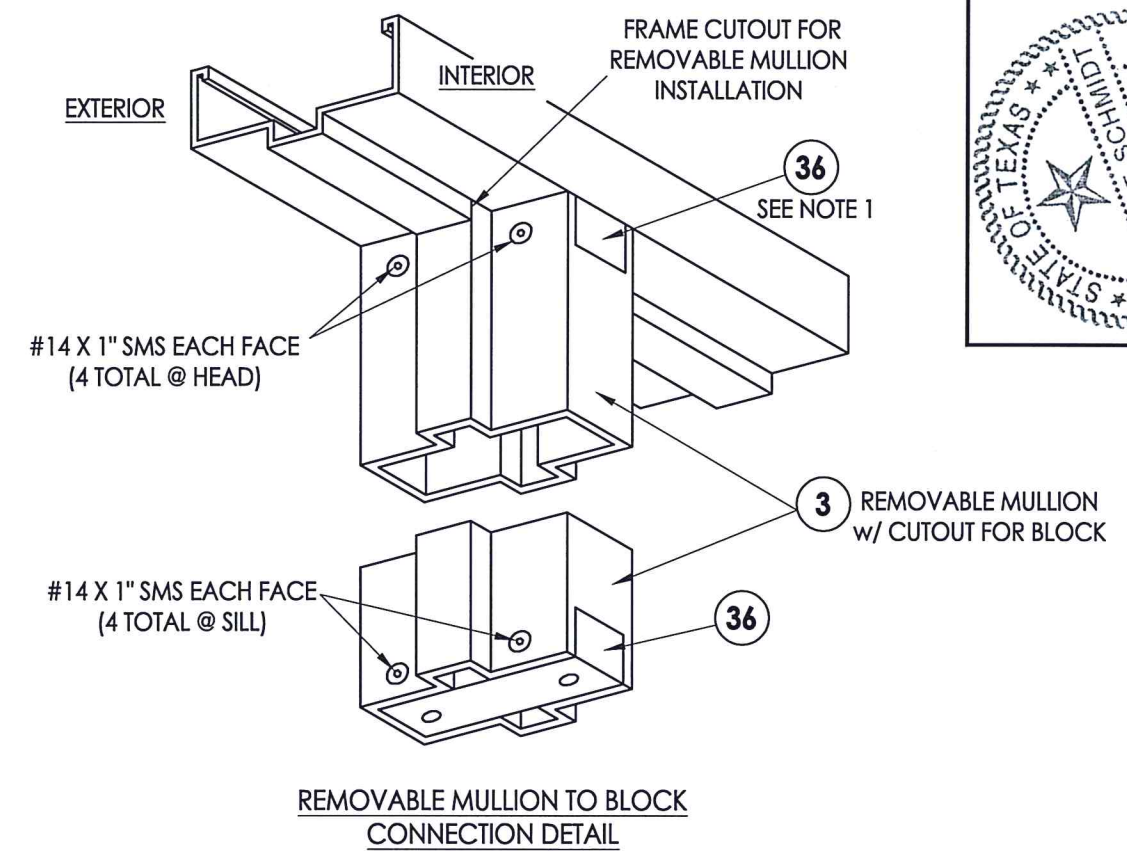

Documents Prepared By: Lyndon F. Schmidt, P.E.
TEXAS P.E. #104123

RW BUILDING CONSULTANTS, INC.
P.O. Box 230 Valrico FL 33595
Phone No.: 813.659.9197

CERTIFICATE OF REGISTRATION # F-11852

PRODUCT:	FIBERGLASS DOOR	
PART OR ASSEMBLY:	VERTICAL CROSS SECTIONS	
NO.	DATE	BY
1	1/19/22	LFS
UPDATE TO 2018 IBC/IRC		
REVISIONS		
DATE:	5/14/18	
SCALE:	N.T.S.	
DWG. BY:	JK	
CHK. BY:	LFS	
DRAWING NO.:	TX-4835	
SHEET	5	OF 7

Z:\Clients\Senneca\B - Texas Dept of Ins\Chem-Pruf\DR 980 Chem-Pruf\Fiberglass Door - Non-Impact\Drawings\TX-4834.35.36 REV.dwg

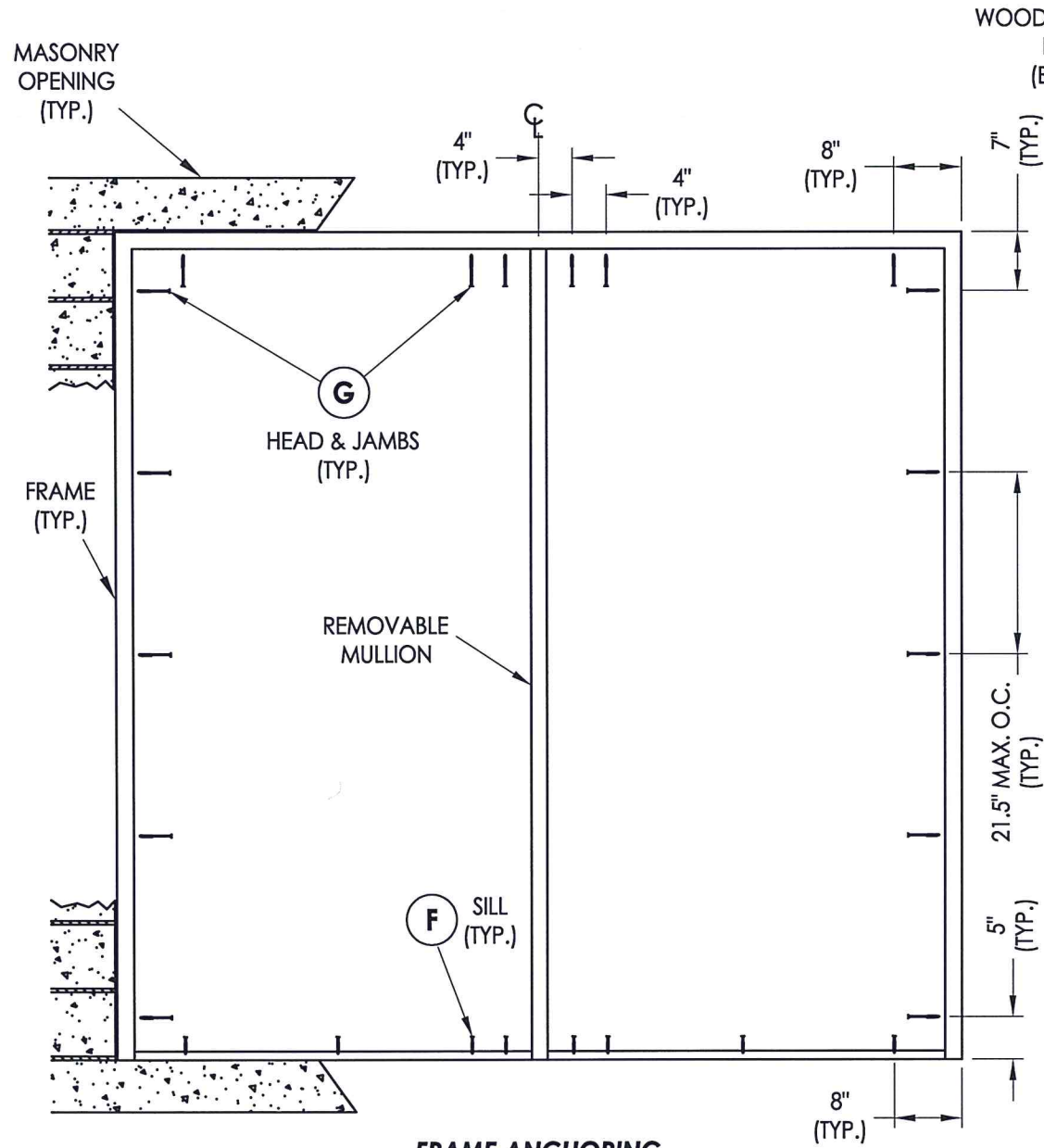

FRAME ANCHORING
Masonry Construction

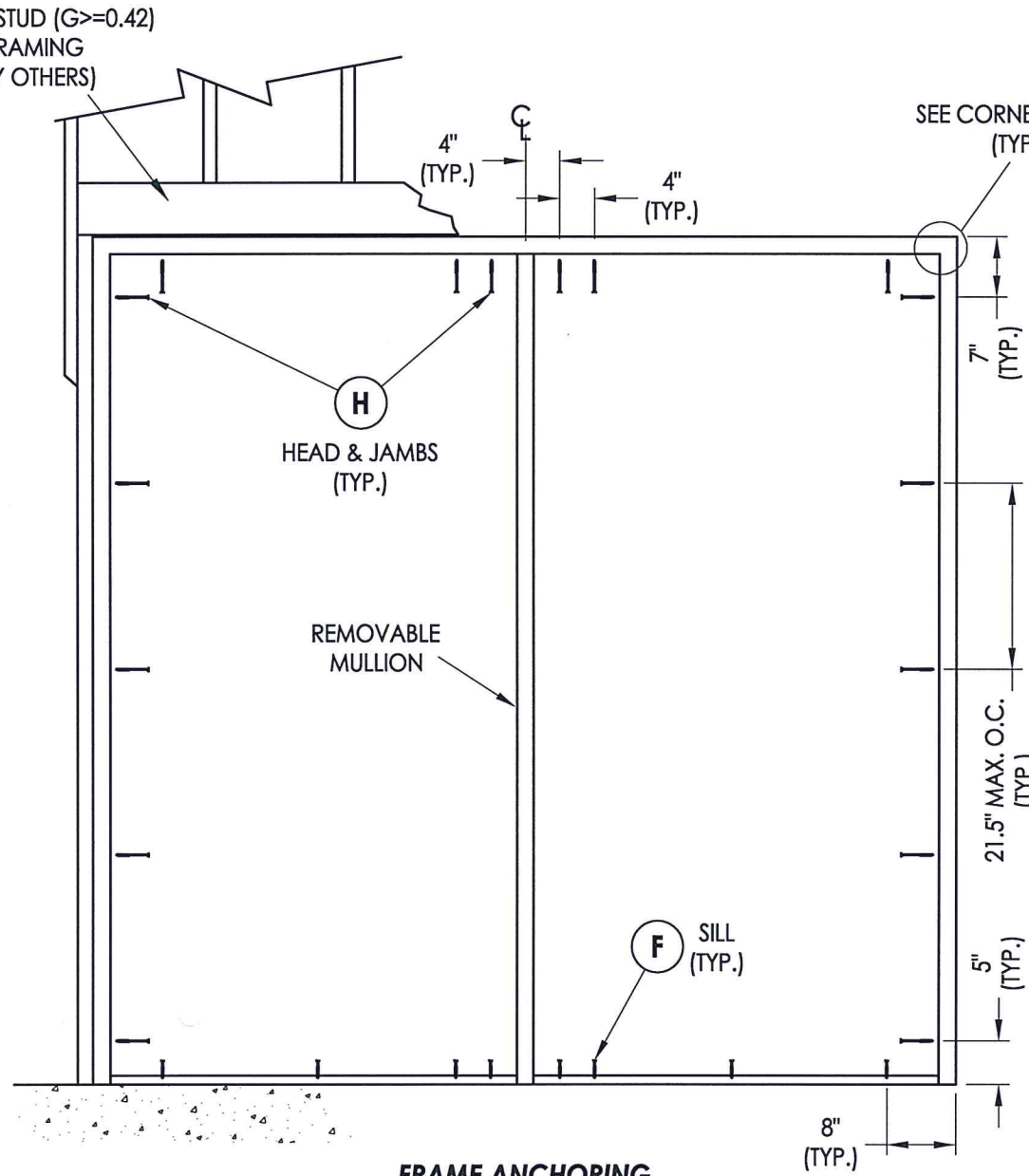

FRAME ANCHORING
Wood Stud

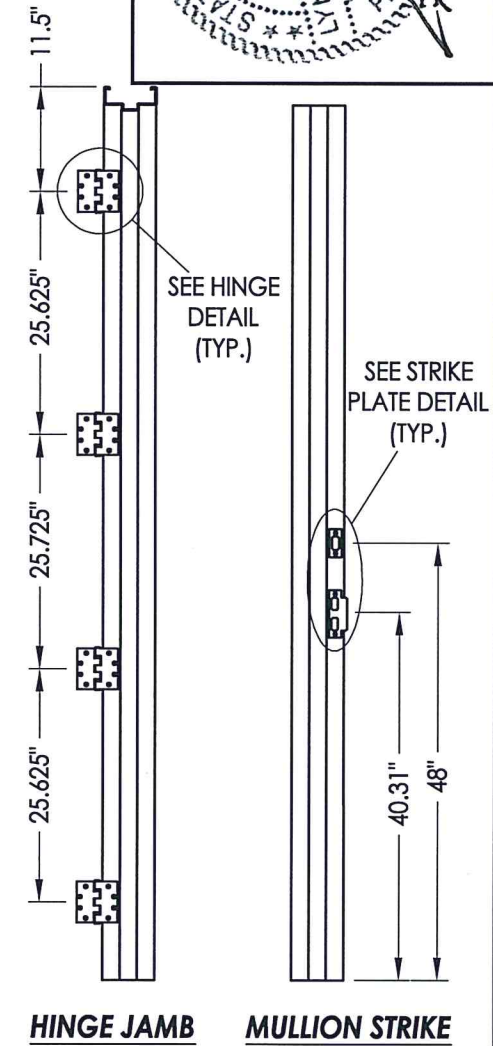

HINGE JAMB **MULLION STRIKE**

CONCRETE ANCHOR NOTES:

- Concrete screw locations at the corners may be adjusted to maintain a minimum 1" edge distance to mortar joints. If concrete screw locations noted as "MAX. O.C." must be adjusted to maintain the minimum edge distance to mortar joints, additional concrete screws may be required to ensure the maximum on center dimension is not exceeded.
- Concrete anchor table:

ANCHOR TYPE	ANCHOR LOCATION	ANCHOR SIZE	MANUFACTURER	MIN. EDGE DISTANCE	MIN. EMBEDMENT
CONCRETE ANCHOR SCREW	SILL	1/4"	TAPCON® (ITW BUILDEX) ULTRACON+® (DeWALT)	2-1/2"	1-3/4"
CONCRETE SLEEVE ANCHOR	HEAD/JAMBS	3/8"	DYNABOLT SLEEVE ANCHOR® (ITW REDHEAD)	2-1/4"	1-1/2"

SECURED TO THE FRAME w/
LORD 7542A/B ADHESIVE

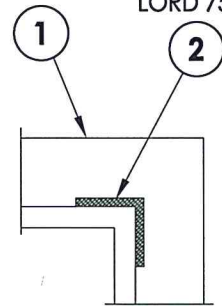

CORNER DETAIL

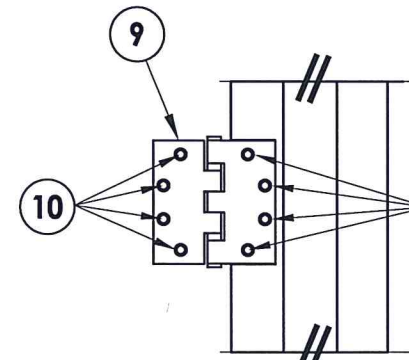

HINGE DETAIL

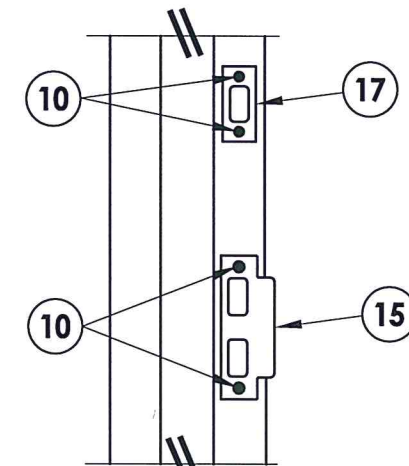

STRIKE PLATE DETAIL

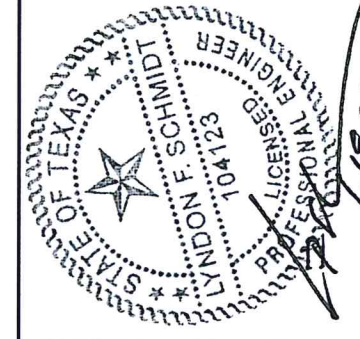

Documents Prepared By: Lyndon F. Schmidt, P.E.
TEXAS P.E. #104123

RW BUILDING CONSULTANTS, INC.
P.O. Box 230 Valrico FL 33595
Phone No.: 813.659.9197

CERTIFICATE OF REGISTRATION # F-11852

PRODUCT:	FIBERGLASS DOOR	
PART OR ASSEMBLY:	FRAME ANCHORING & HARDWARE DETAILS	
NO.	DATE	BY
1	1/19/22	LFS
UPDATE TO 2018 IBC/IRC		
DATE:	5/14/18	
SCALE:	N.T.S.	
DWG. BY:	JK	
CHK. BY:	LFS	
DRAWING NO.:	TX-4835	
SHEET	6	OF 7

© 2018 R.W. BUILDING CONSULTANTS INC.

Z:\Clients\Semeca\B - Texas Dept of Ins\Chem-Pruf\DR 980 Chem-Pruf Fiberglass Door - Non-Impact\Drawings\TX-4834.35.36 REV.dwg

BILL OF MATERIALS

ITEM #	DESCRIPTION	MATERIAL
C	1/4" MAX. SHIM SPACE	-
E	MASONRY - 3,000 PSI MIN. CONCRETE CONFORMING TO ACI 301 OR HOLLOW BLOCK (GROUT FILLED) CONFORMING TO ASTM C90	CONCRETE
F	1/4" x 2-3/4" PFH DeWALT OR ITW CONCRETE SCREW	STEEL
G	3/8"Ø DYNABOLT SLEEVE ANCHOR	STEEL
H	3/8"Ø x 5" LAG SCREW	STEEL
1	DOOR FRAME (FRP)	FIBERGLASS
2	FRAME CORNER REINFORCEMENT (FRP)	FIBERGLASS
3	REMOVABLE MULLION (FRP)	FIBERGLASS
6	WEATHERSTRIP	NEOPRENE
7	DOOR SWEEP	VINYL
9	4-1/2" X 4-1/2" BUTT HINGE	SS
10	#12 X 1" PFH SMS	SS
15	MORTISE LATCH & DEADBOLT STRIKE PLATE	SS
16	LATCH STRIKE PLATE	SS
17	DEADBOLT STRIKE PLATE	STEEL
30	OUTSWING THRESHOLD	ALUM
36	REMOVABLE MULLION FRAME BLOCKS (1-1/2" X 1-1/2" X 5-1/2")	FIBERGLASS
40	DOOR PANEL - SEE DOOR PANEL DETAIL SHEET FOR CONSTRUCTION DETAILS	-

FIBER REINFORCED PLASTIC (FRP)

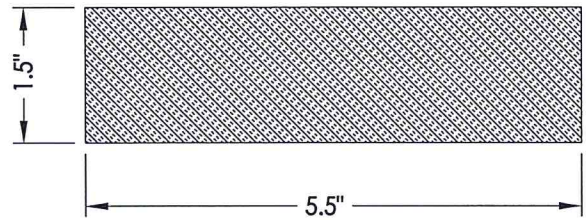

36 REMOVABLE MULLION FRAME BLOCK (FRP)
1.5" WIDE

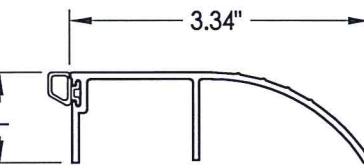

30 OUTSWING THRESHOLD
Pemko 2051-T

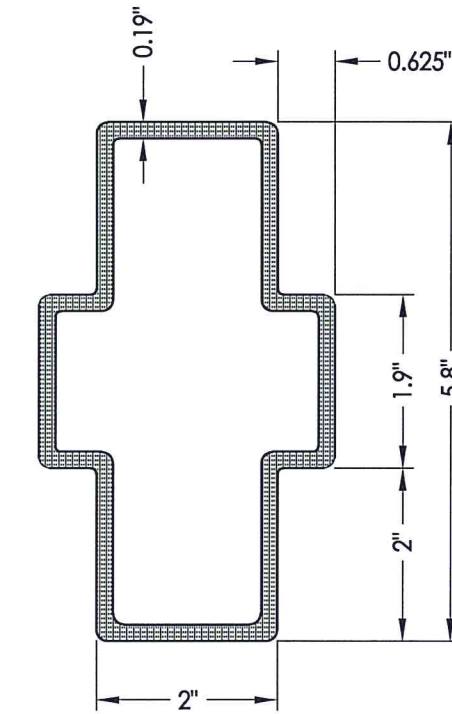

3 REMOVABLE MULLION (FRP)

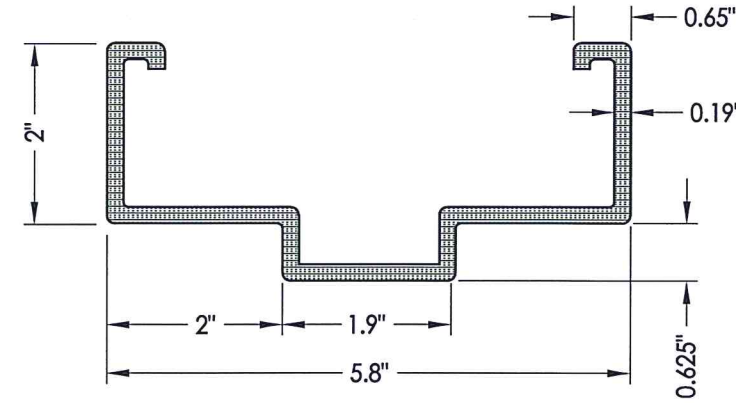

1 DOOR FRAME (FRP)

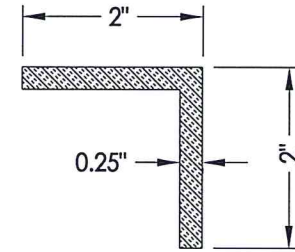

2 FRAME CORNER REINFORCEMENT
5" LONG

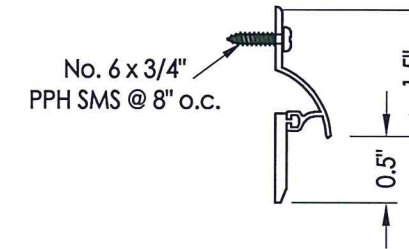

7 DOOR SWEEP
NGP 101 VA

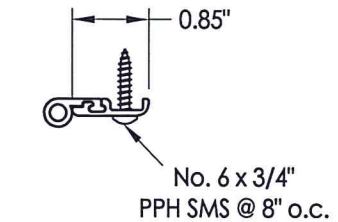

6 WEATHERSTRIP
NGP 137N

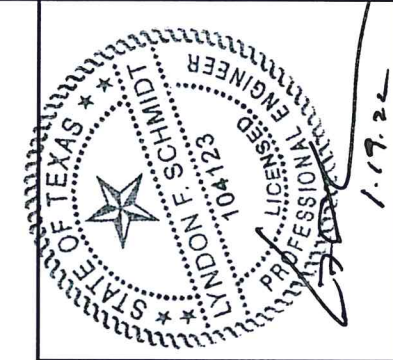

Documents Prepared By: Lyndon F. Schmidt, P.E.
TEXAS P.E. #104123

RW BUILDING CONSULTANTS, INC.
P.O. Box 230 Valrico FL 33595
Phone No.: 813.659.9197

CERTIFICATE OF REGISTRATION # F-11852

PRODUCT:	FIBERGLASS DOOR	
PART OR ASSEMBLY:	BILL OF MATERIALS & COMPONENTS	
NO.	DATE	BY
1	1/19/22	LFS
UPDATE TO 2018 IBC/IRC		
REVISIONS		
DATE:	05/14/18	
SCALE:	N.T.S.	
DWG. BY:	JK	
CHK. BY:	LFS	
DRAWING NO.:	TX-4835	
SHEET	7	OF 7