

SPECIAL-LITE, INC.

ALUMINUM FRAME OUTSWING DOORS LARGE AND SMALL MISSILE IMPACT (HVHZ)

SERIES 16, 17, 19-1, & 20 ALUMINUM FRAME OUTSWING DOOR (LMI & SMI)

- THIS PRODUCT HAS BEEN DESIGNED AND TESTED TO COMPLY WITH THE REQUIREMENTS OF THE 2006 INTERNATIONAL BUILDING CODE AND THE 2006 INTERNATIONAL RESIDENTIAL CODE, TO BE USED INSIDE HIGH VELOCITY HURRICANE ZONE (HVHZ).
- DOORS RATED FOR LARGE AND SMALL MISSILE IMPACT AND DO NOT REQUIRE SHUTTERS.
- DOORS WITH WATER RESISTANT COMPONENTS APPROVED FOR WATER INFILTRATION, REFER TO DETAILS ON SHEET D1.
- ANCHORS SHALL BE AS LISTED, SPACED AS SHOWN ON ELEVATIONS. ANCHORS EMBEDMENT TO BASE MATERIAL SHALL BE BEYOND WALL DRESSING OR STUCCO.
- ANCHORING OR LOADING CONDITIONS NOT SHOWN IN THESE DETAILS ARE NOT PART OF THIS APPROVAL.
- MATERIALS INCLUDING BUT NOT LIMITED TO STEEL/METAL SCREWS THAT COME INTO CONTACT WITH OTHER DISSIMILAR MATERIALS SHALL MEET THE REQUIREMENTS OF THE 2006 INTERNATIONAL BUILDING CODE AND THE 2006 INTERNATIONAL RESIDENTIAL CODE SECTION AS APPLICABLE.

- METAL STRUCTURES NOT BY SPECIAL-LITE, INC. MUST SUPPORT LOADS IMPOSED BY DOOR SYSTEM AND TRANSFER THEM TO THE BUILDING STRUCTURE.
- WOOD BUCKS BY OTHERS MUST BE ANCHORED PROPERLY TO TRANSFER LOADS TO THE STRUCTURE.
- A LOAD DURATION FACTOR IN ALLOWABLE STRESS IS USED IN DESIGN OF ANCHORS INTO WOOD ONLY.
- DOOR PANEL: 0.120" PEBBLE FRP SKIN, 0.0625" ALUMINUM SKIN, 0.120" SANDSTONE FRP SKIN, 0.125" ALUMINUM SKIN OR 0.120" AMP SKIN.
- DOOR FRAME: ALUMINUM 6063-T6
- THE DESIGN LOADS SHOWN IN THIS DOCUMENT ARE ALLOWABLE DESIGN LOADS. ULTIMATE LOAD OBTAINED FROM ASCE 7-10, MULTIPLY BY 0.6 SHALL BE LESS THAN OR EQUAL TO MAX. DESIGN LOAD IN THIS DOCUMENT.
- LOCK:
REFER TO SHEET HW1 FOR LOCK OPTIONS.
- NOTE:
EGRESS REQUIREMENTS TO BE REVIEWED BY BUILDING OFFICIAL.

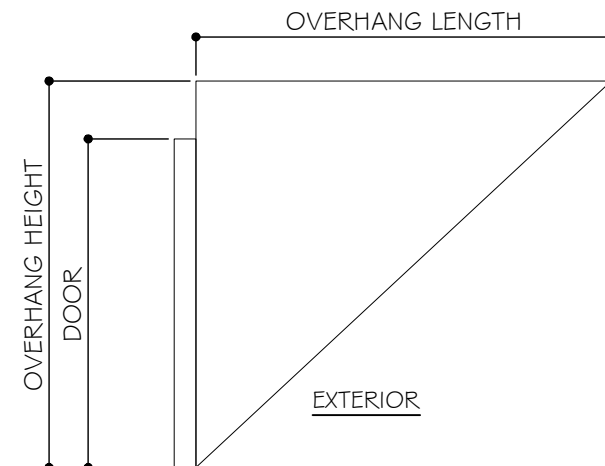

$$OH \text{ RATIO} = \frac{\text{OVERHANG LENGTH}}{\text{OVERHANG HEIGHT}} \geq 1$$

NOTE #1:
UNITS NOT APPROVED FOR WATER INFILTRATION MUST BE INSTALLED AT LOCATIONS PROTECTED BY AN OVERHANG MEETING CRITERIA AS PER ILLUSTRATION ABOVE OR IN NON-HABITABLE AREAS WHERE WATER INFILTRATION IS ACCEPTABLE.

ABBREVIATIONS AND SYMBOLS

- D.L.O. - DAYLITE OPENING
- F.H. - FRAME HEIGHT
- F.W. - FRAME WIDTH
- W/ - WITH
- W/O - WITHOUT
- O.C. - ON CENTER
- MAX. - MAXIMUM

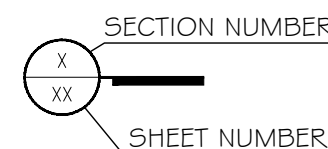

PRODUCT CONTROL APPROVAL

AFISU OLABIMTAN, P.E.
TEXAS REGISTRATION
TX #63663



COVER

DATE	10/19/18
SCALE	AS SHOWN
DRAWN	T.G.
PROJECT	17-047

DRAWING NO.
TA17-01

1 OF 13

ALUMINUM FRAME OUTSWING DOORS

SPECIAL-LITE, INC.
860 SOUTH WILLIAMS STREET
P.O. BOX 6
DECATUR, MI 49045
WWW.SPECIAL-LITE.COM



MCY ENGINEERING, INC.
GLAZING CONSULTANTS

8501 SW 124 AVE. STE. 205A P: 305.271.0117
MIAMI, FL. 33183 F: 786.573.5063
www.MCYUS.com

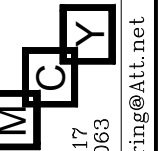

NO.	DATE	REVISIONS	DESCRIPTION

ANCHOR TYPE	MAX. SHIM	# OF ANCHOR REQUIRED
A	1/2"	6
B	1/2"	5
C	1/4"	3

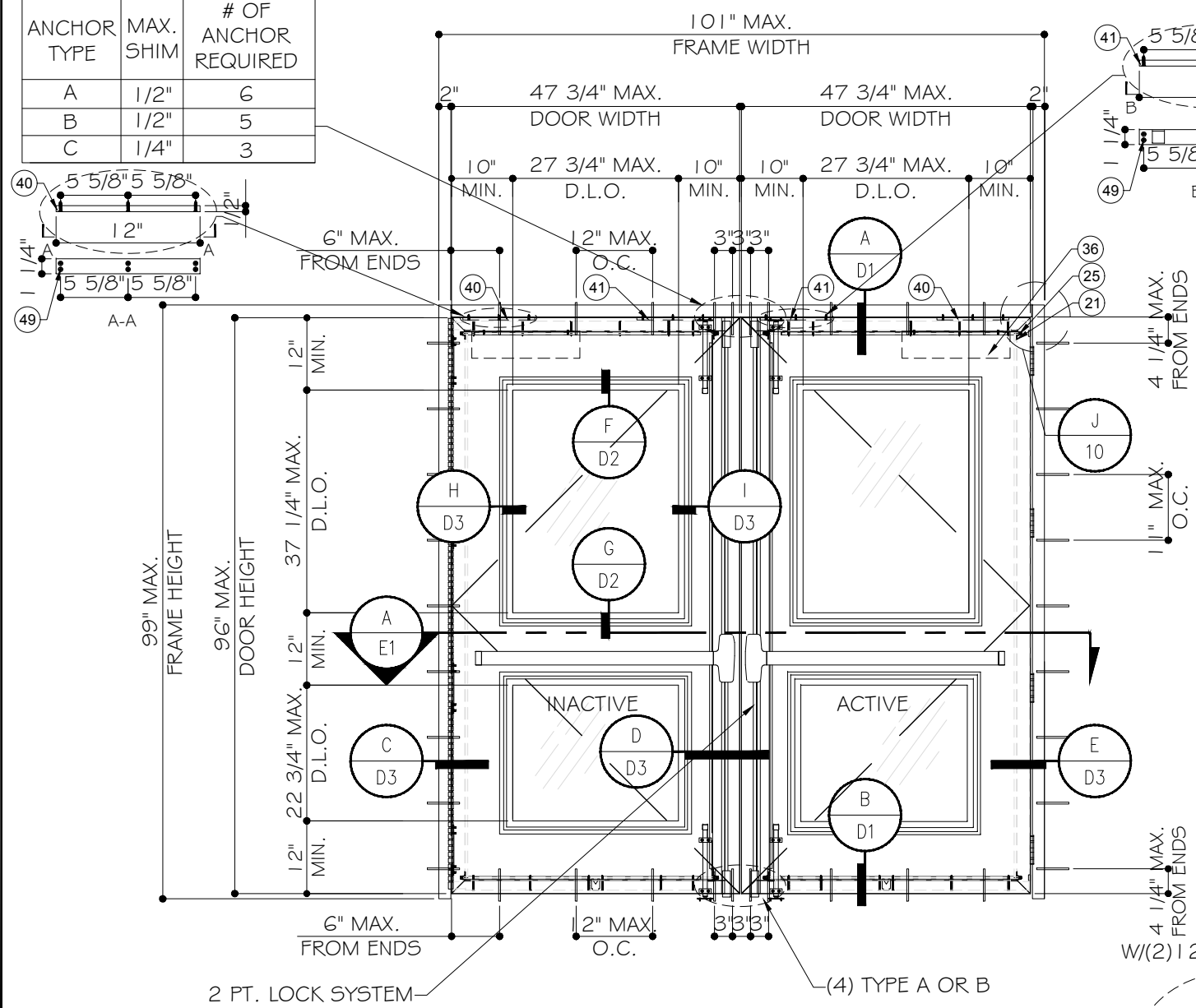

TYPICAL EXTERIOR ELEVATION (XX)

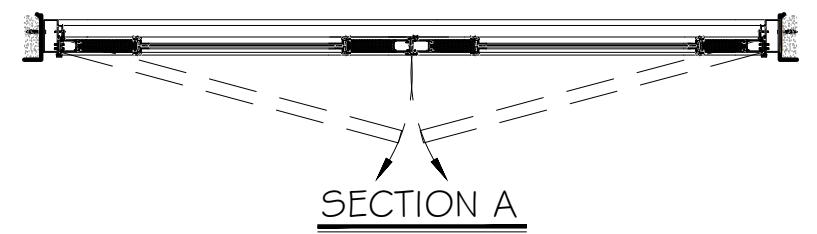

SECTION A

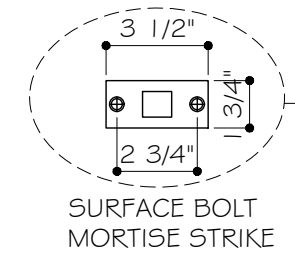

SURFACE BOLT MORTISE STRIKE

FOR LOCK OPTIONS SEE SHEET HW 1

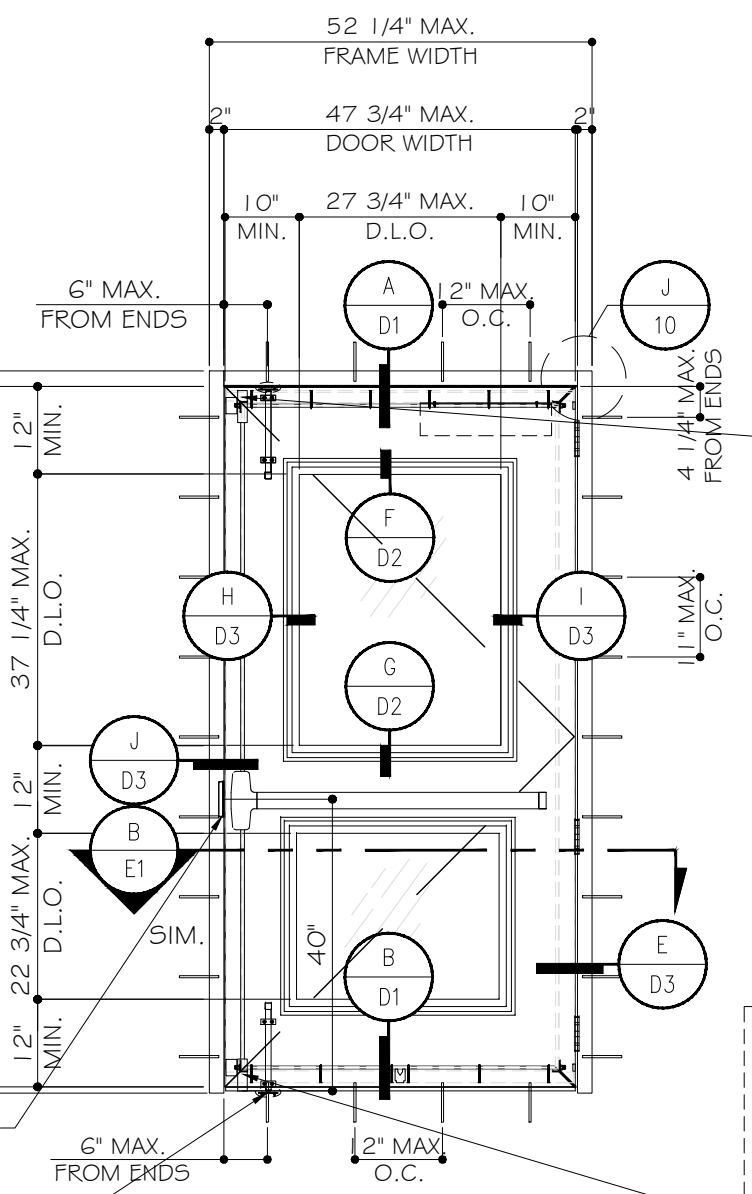

TYPICAL EXTERIOR ELEVATION (X)

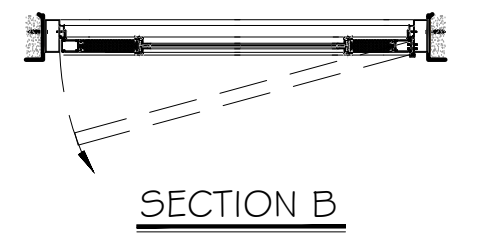

SECTION B

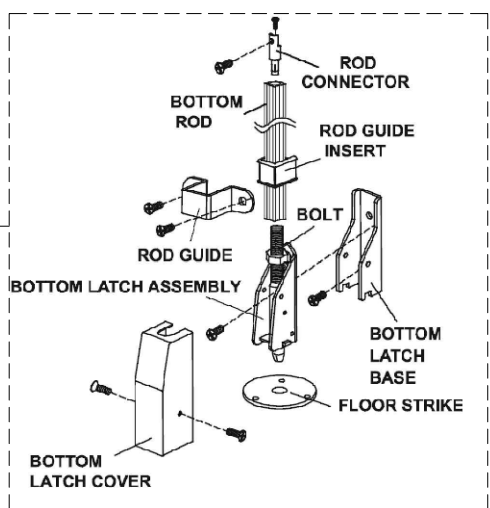
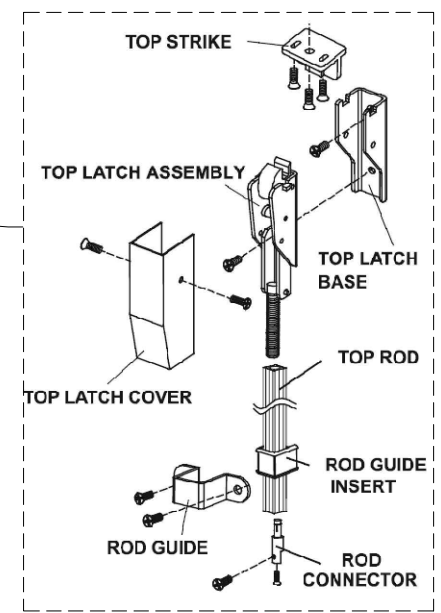

DESIGN LOADS (FOR SIZES SHOWN OR SMALLER) AS PERMITTED BY IBC/IRC	DESIGN LOADS (FOR SIZES SHOWN OR SMALLER) AS PERMITTED BY IBC/IRC
APPROVED FOR WATER INFILTRATION	NOT APPROVED FOR WATER INFILTRATION
+ 47.0 PSF - 65.0 PSF	+ 65.0 PSF - 65.0 PSF

DESIGN LOADS (FOR SIZES SHOWN OR SMALLER) AS PERMITTED BY IBC/IRC
WITH OR WITHOUT WATER INFILTRATION
+ 65.0 PSF - 65.0 PSF

PRODUCT CONTROL APPROVAL

AFISU OLABIMTAN, P.E.
TEXAS REGISTRATION
TX #63663

E1	
DATE	10/19/18
SCALE	AS SHOWN
DRAWN	T.G.
PROJECT	17-047
DRAWING NO. TA17-01	
2 OF 13	

NO.	DATE	DESCRIPTION

MCY ENGINEERING, INC.
GLAZING CONSULTANTS

8501 SW 124 AVE. STE. 205A P: 305.271.0117
MIAMI, FL. 33183 F: 786.573.5063

www.MCYUS.com
www.MCYEngineering@Att.net

SPECIAL-LITE, INC.
ALUMINUM FRAME OUTSWING DOORS

860 SOUTH WILLIAMS STREET
P.O. BOX 6
DECATUR, MI 49045
WWW.SPECIAL-LITE.COM



ANCHOR TYPE	MAX. SHIM	# OF ANCHOR REQUIRED
A	1/2"	5
B	1/2"	5
C	1/4"	3

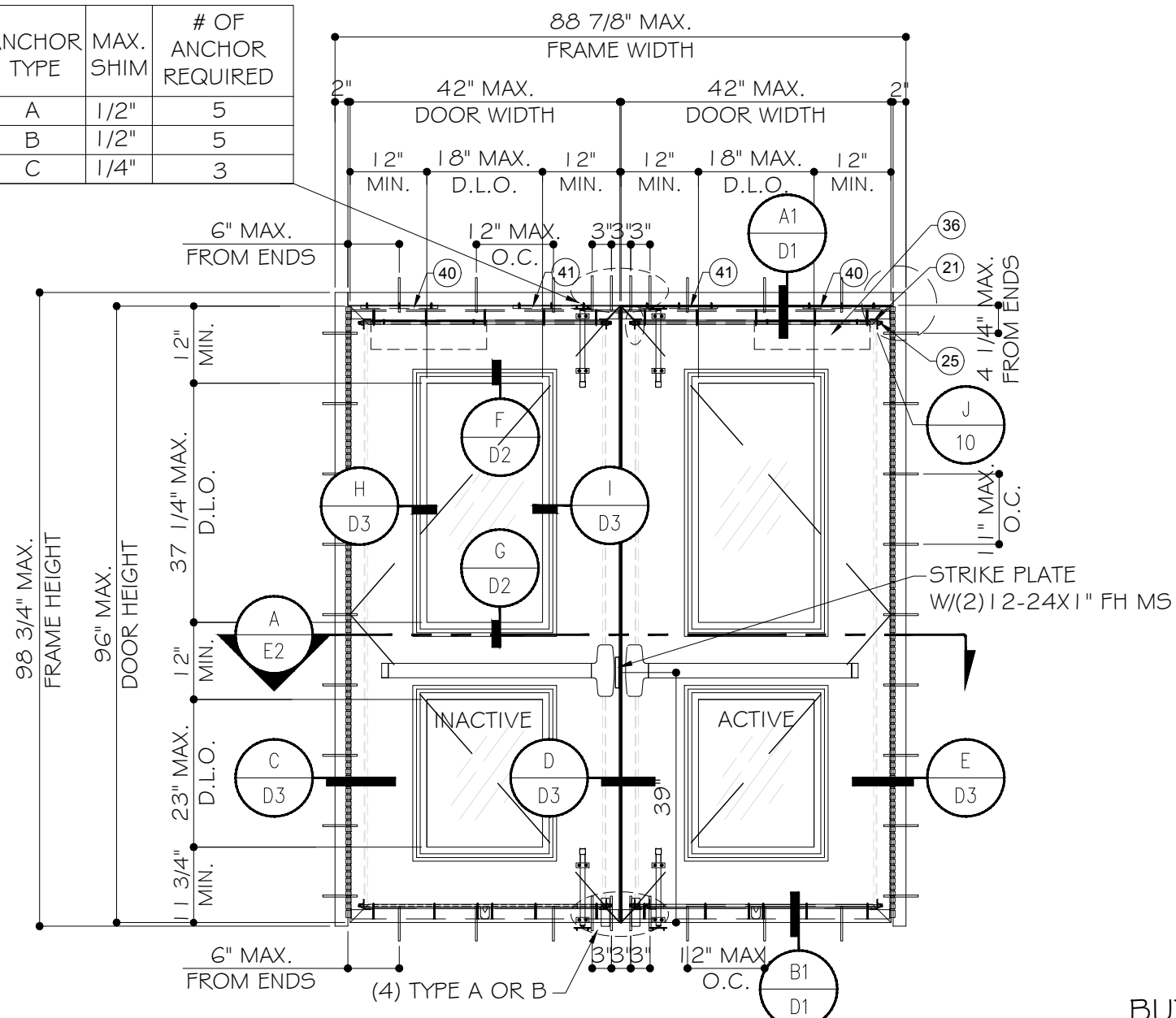

TYPICAL EXTERIOR ELEVATION (XX)

BUTT HINGE LAYOUT

CONT. HINGE LAYOUT

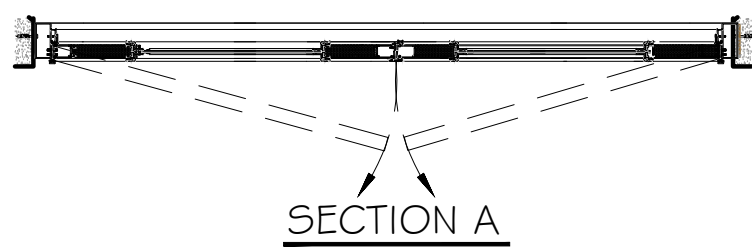

SECTION A

DESIGN LOADS (FOR SIZES SHOWN OR SMALLER) AS PERMITTED BY IBC/IRC
NOT APPROVED FOR WATER INFILTRATION
+65.0 PSF -65.0 PSF

FOR LOCK OPTIONS
SEE SHEET HW1

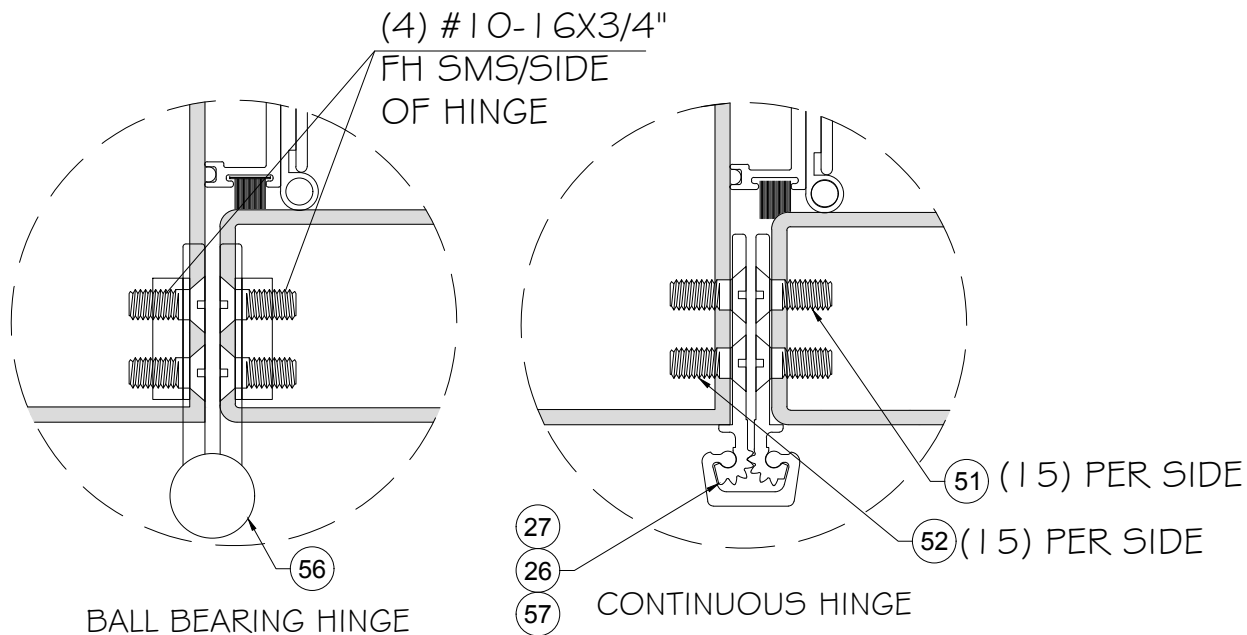

HINGE OPTIONS

PRODUCT CONTROL APPROVAL

AFISU OLABIMTAN, P.E.
TEXAS REGISTRATION
TX #63663



NO.	DATE	DESCRIPTION

MCY ENGINEERING, INC.
GLAZING CONSULTANTS

8501 SW 124 AVE. STE. 205A P: 305.271.0117
MIAMI, FL. 33183 F: 786.573.5063
www.MCYUS.com

SPECIAL-LITE, INC.
860 SOUTH WILLIAMS STREET
P.O. BOX 6
DECATUR, MI 49045
WWW.SPECIAL-LITE.COM

ALUMINUM FRAME OUTSWING DOORS

Special-Lite
Doors with more life.

E2	
DATE	10/15/18
SCALE	AS SHOWN
DRAWN	T.G.
PROJECT	17-047
DRAWING NO.	TA17-01
3 OF 13	

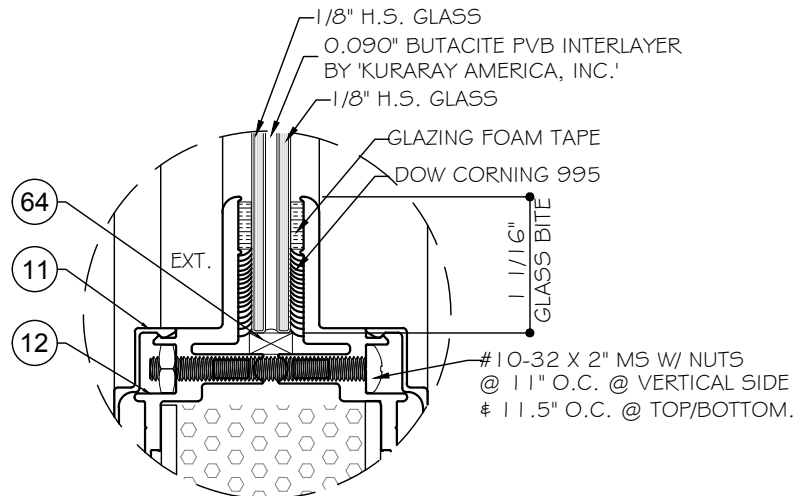

GLASS TYPE 'G1'
5/16" NOMINAL OVERALL

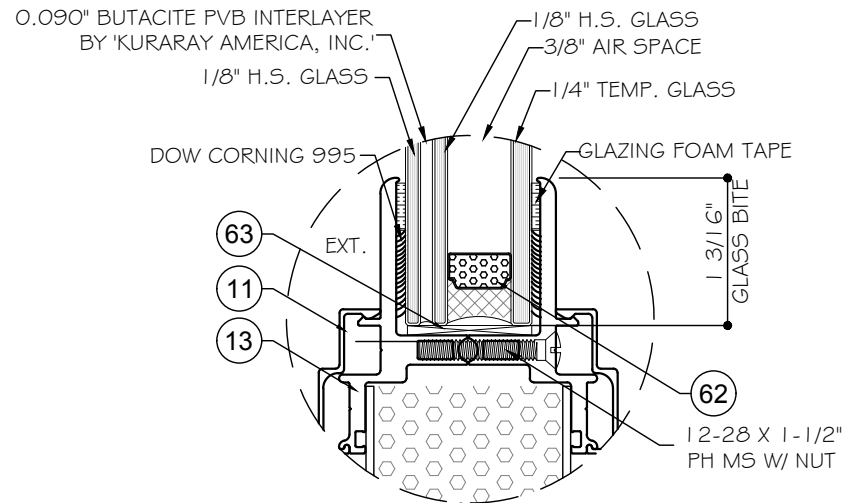

GLASS TYPE 'G2'
1" NOMINAL OVERALL

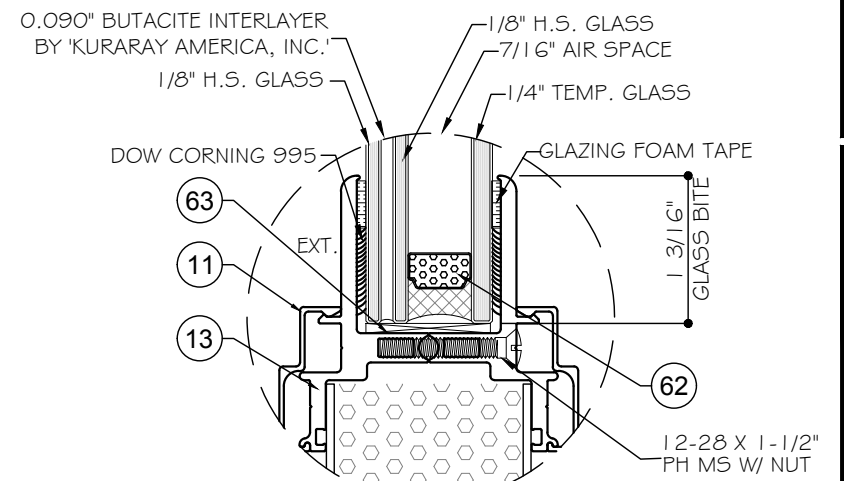

GLASS TYPE 'G3'
1" NOMINAL OVERALL

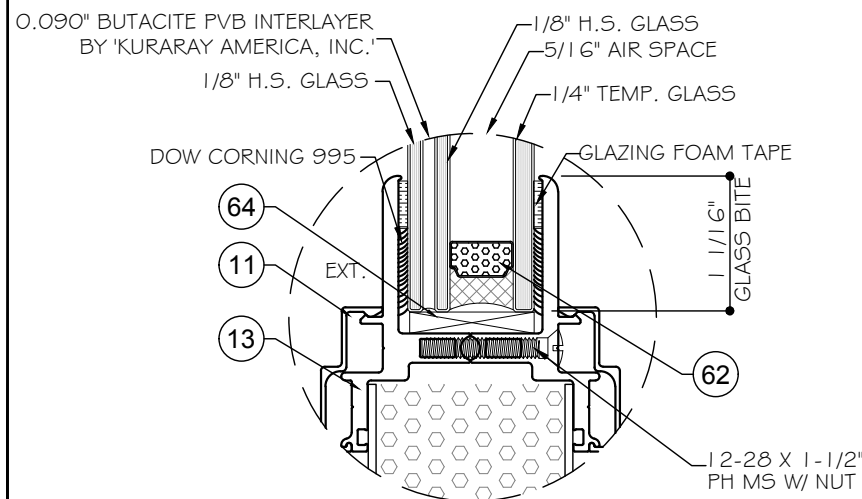

GLASS TYPE 'G4'
1" NOMINAL OVERALL

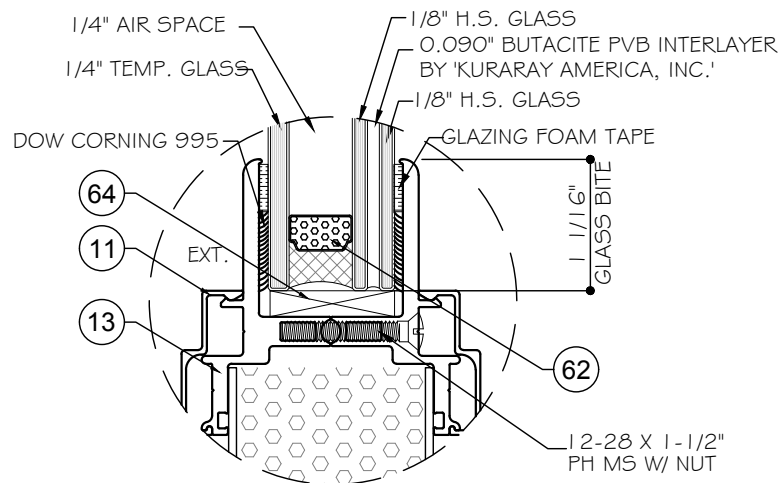

GLASS TYPE 'G5'
7/8" NOMINAL OVERALL

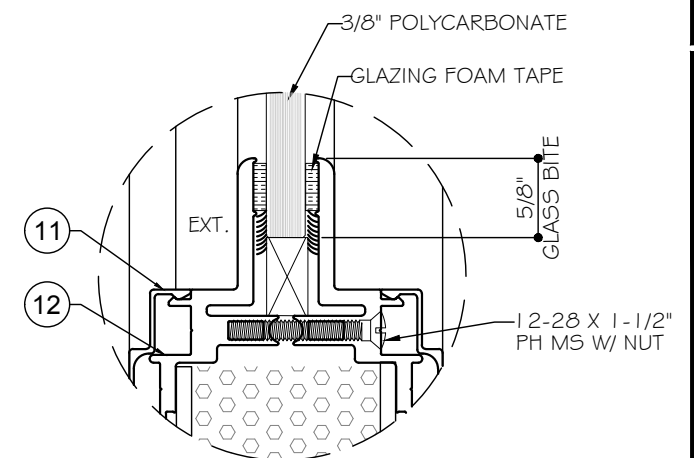

GLASS TYPE 'G6'
5/16" NOMINAL OVERALL

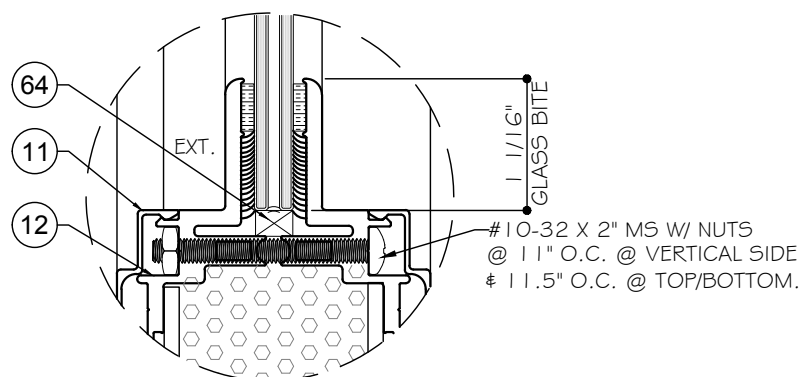

GLAZING CORNER THRU BOLT DETAIL

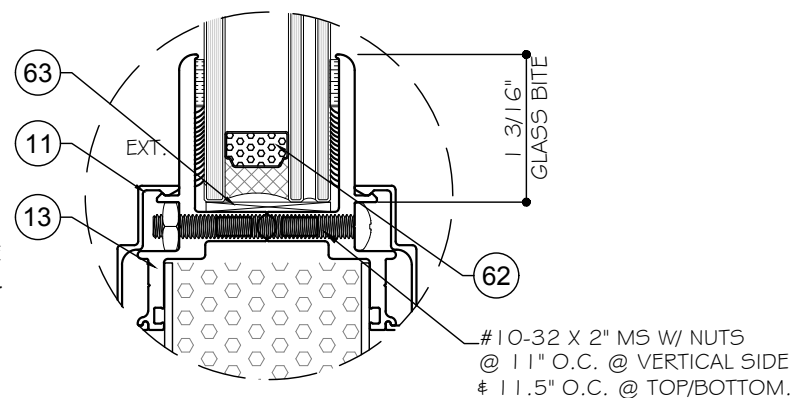

NOTE:
GLASS COMPLIES WITH ASTM
E1300-09 (3 SEC. GUSTS).

PRODUCT CONTROL APPROVAL

AFISU OLABIMTAN, P.E.
TEXAS REGISTRATION
TX #63663



10-18-18

NO.	DATE	DESCRIPTION

MCY ENGINEERING, INC.
GLAZING CONSULTANTS

8501 SW 124 AVE. STE. 205A P: 305.271.0117
MIAMI, FL. 33183 F: 786.573.5063
www.MCYUS.com

ALUMINUM FRAME OUTSWING DOORS

SPECIAL-LITE, INC.
860 SOUTH WILLIAMS STREET
P.O. BOX 6
DECATUR, MI 49045
WWW.SPECIAL-LITE.COM



G1	
DATE	10/19/18
SCALE	AS SHOWN
DRAWN	T.G.
PROJECT	17-047
DRAWING NO. TA17-01	
4 OF 13	

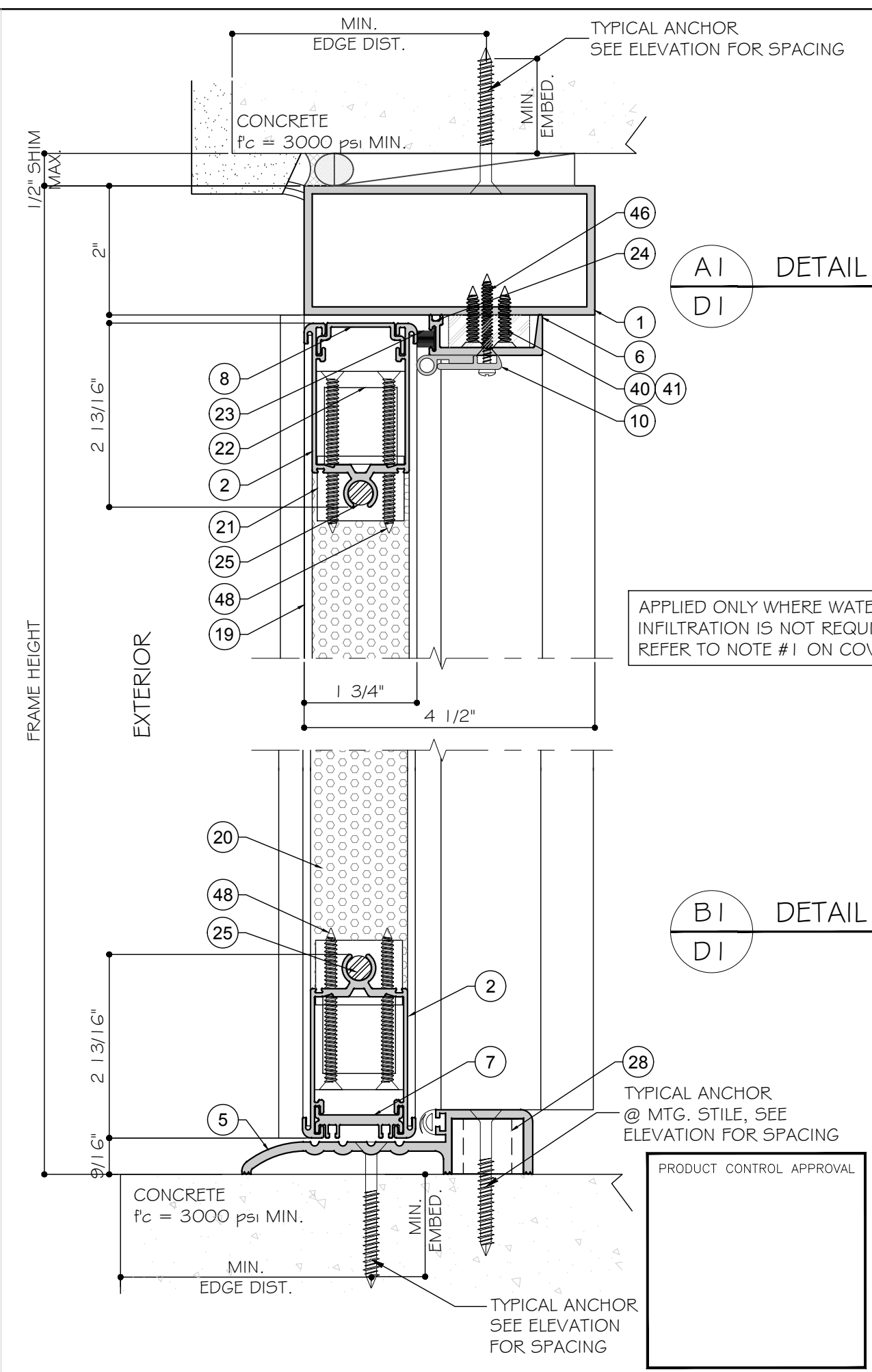
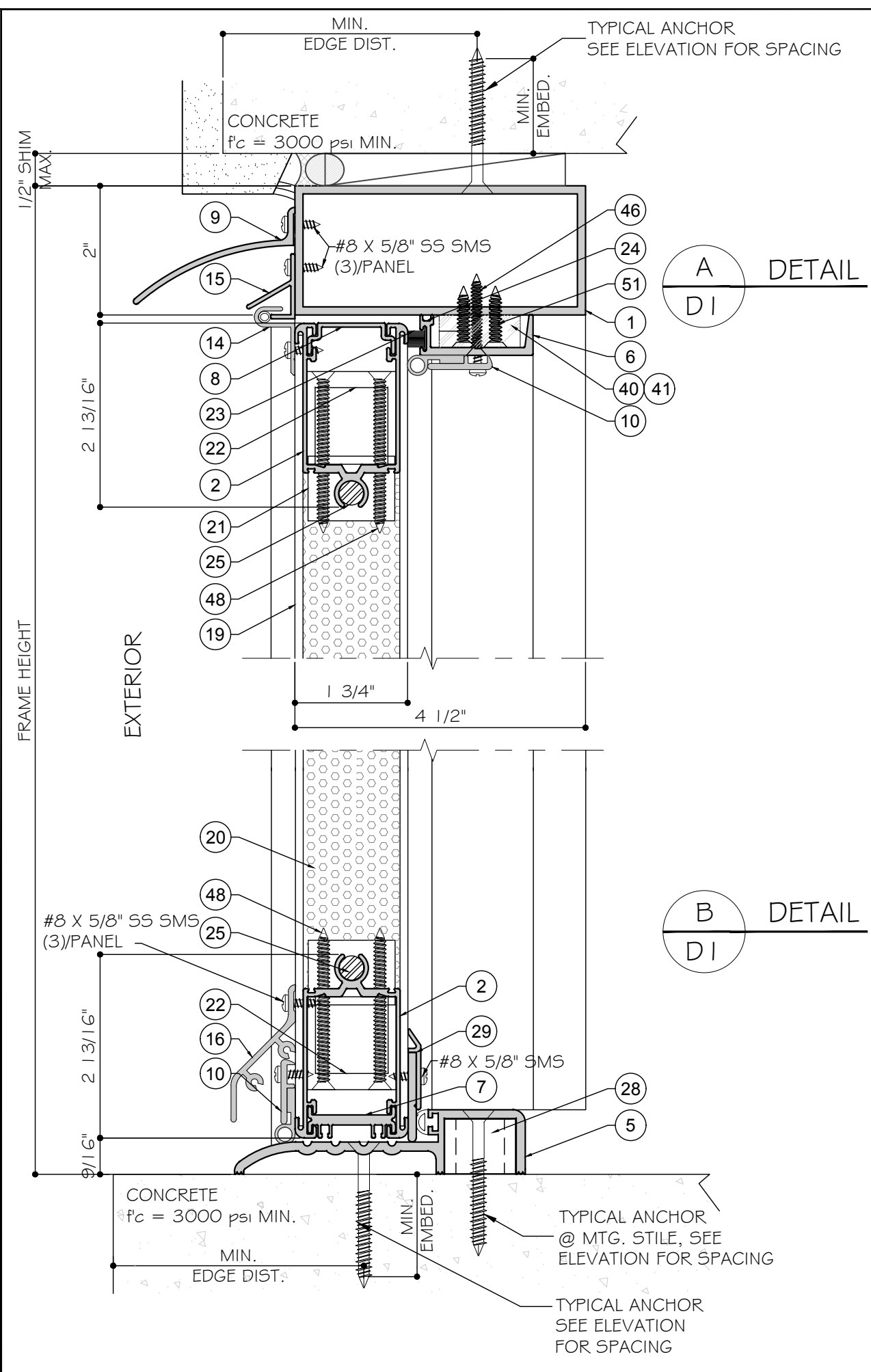

PRODUCT CONTROL APPROVAL

AFISU OLABIMTAN, P.E.
TEXAS REGISTRATION
TX #63663

NO.	DATE	DESCRIPTION

MCY

MCY ENGINEERING, INC.
GLAZING CONSULTANTS

8501 SW 124 AVE. STE. 205A P: 305.271.0117
MIAMI, FL. 33183 F: 786.573.5063
www.MCYUS.com
www.MCYEngineering@Att.net

ALUMINUM FRAME OUTSWING DOORS

SPECIAL-LITE, INC.
860 SOUTH WILLIAMS STREET
P.O. BOX 6
DECATUR, MI 49045
WWW.SPECIAL-LITE.COM



D1

DATE	10/19/18
SCALE	AS SHOWN
DRAWN	T.G.
PROJECT	17-047
DRAWING NO.	TA17-01
5 OF 13	

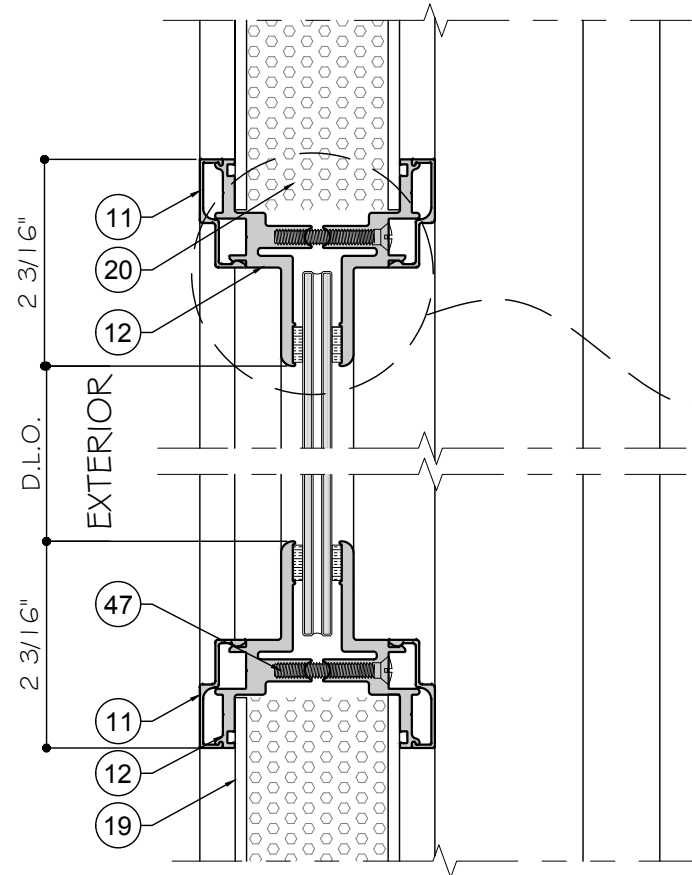
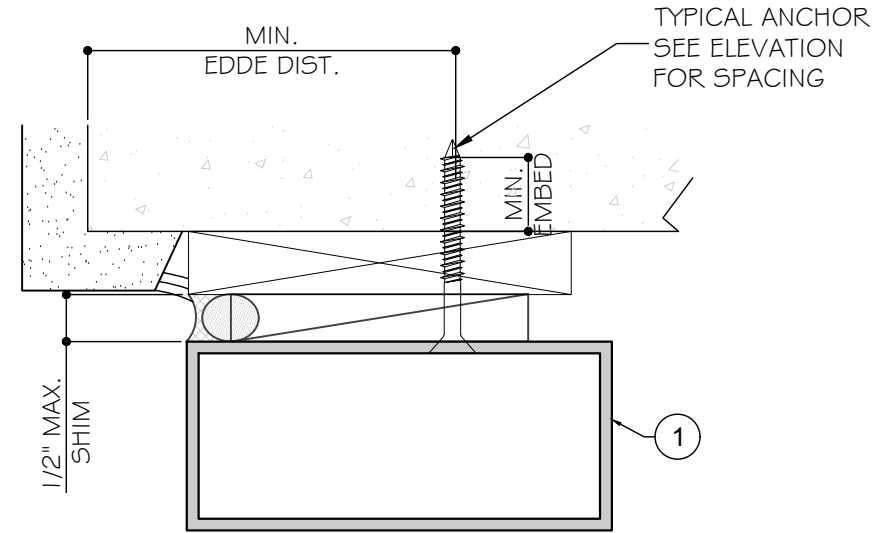
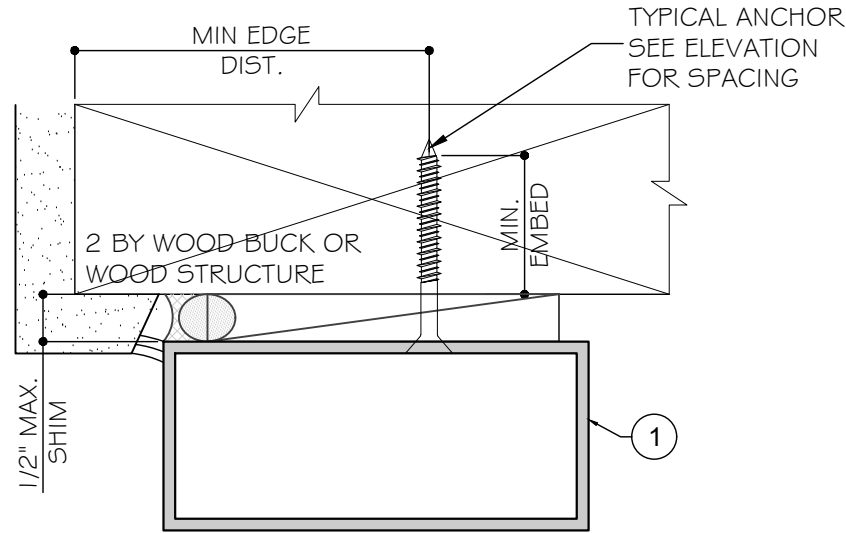
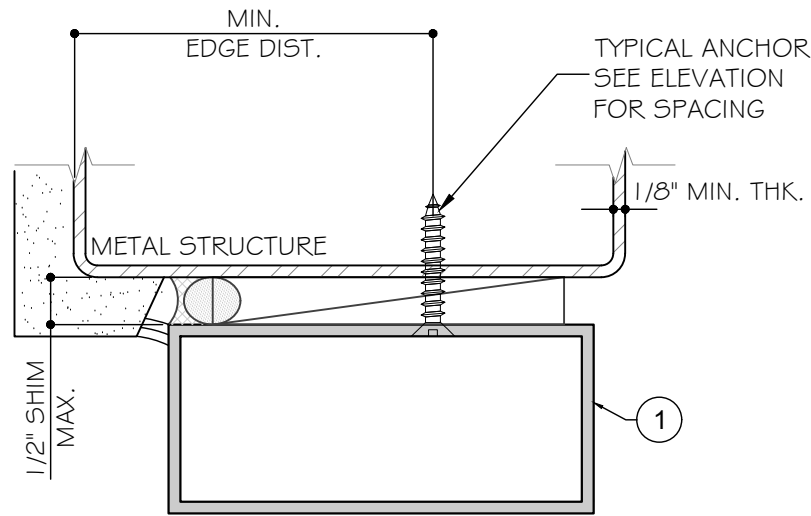

F
D2
DETAIL

GLASS OPTIONS INTERCHANGEABLE.
SEE SHEET G1 FOR GLASS OPTIONS.

G
D2
DETAIL

TYPICAL ANCHORS:

TYPE 'A' - 1/4" DIA. ITW TAPCON (Fu=120 KSI, Fy=92 KSI)
W/ 1 1/2" MIN. EMBED INTO WOOD STRUCTURE OR THRU 1X OR 2X WOOD
BUCK W/ 1 1/2" MIN. EMBED INTO CONCRETE / MASONRY.

TYPE 'B' - 1/4" DIA. ELCO ULTRACON (Fu=177 KSI, Fy=155 KSI)
W/ 1 1/2" MIN. EMBED INTO WOOD STRUCTURE OR THRU 1X OR 2X WOOD
BUCK W/ 1 1/2" MIN. EMBED INTO CONCRETE / MASONRY.

TYPE 'C' - #14 SMS OR TEKS SELF DRILLING SCREW (GRADE 5)
INTO METAL STRUCTURE.

SUBSTRATE:

CONCRETE: $f_c=3$ KSI MIN. (HEAD/SILL OR JAMB)
MASONRY: $f_c=2$ KSI MIN. (JAMB ONLY)
WOOD: SG=0.55 MIN. (HEAD/JAMB)
STEEL: 1/8" MIN. THK., A36 MIN. (HEAD/JAMB)

TYPICAL EDGE DISTANCE:

INTO CONCRETE/MASONRY: 2 1/2" MIN.
INTO WOOD: 1" MIN.
INTO METAL: 3/4" MIN.

NO.	DATE	DESCRIPTION

MCY ENGINEERING, INC.
GLAZING CONSULTANTS
8501 SW 124 AVE. STE. 205A P: 305.271.0117
MIAMI, FL. 33183 F: 786.573.5063
www.MCYUS.com
www.MCYEngineering@Att.net

ALUMINUM FRAME OUTSWING DOORS
SPECIAL-LITE, INC.
860 SOUTH WILLIAMS STREET
P.O. BOX 6
DECATUR, MI 49045
WWW.SPECIAL-LITE.COM



PRODUCT CONTROL APPROVAL

AFISU OLABIMTAN, P.E.
TEXAS REGISTRATION
TX #63663

D2

DATE	10/19/18
SCALE	AS SHOWN
DRAWN	T.G.
PROJECT	17-047
DRAWING NO.	TA17-01
6 OF 13	

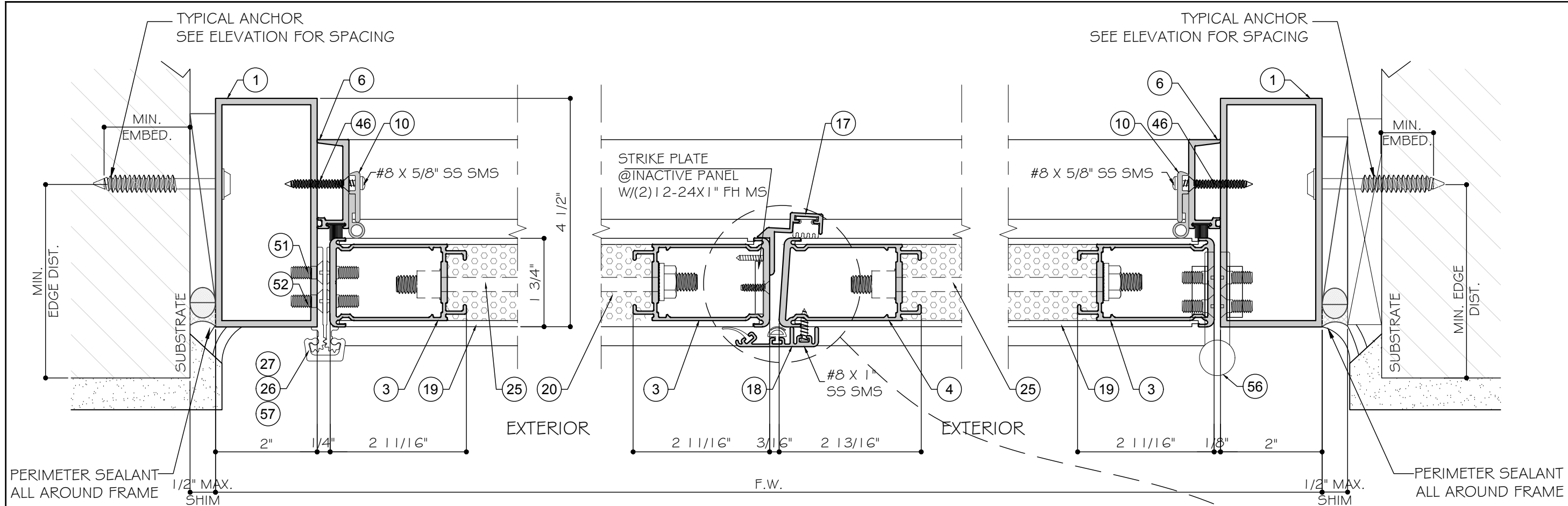

C DETAIL
D3

GLASS OPTIONS INTERCHANGEABLE. SEE SHEET G1 FOR GLASS OPTIONS.

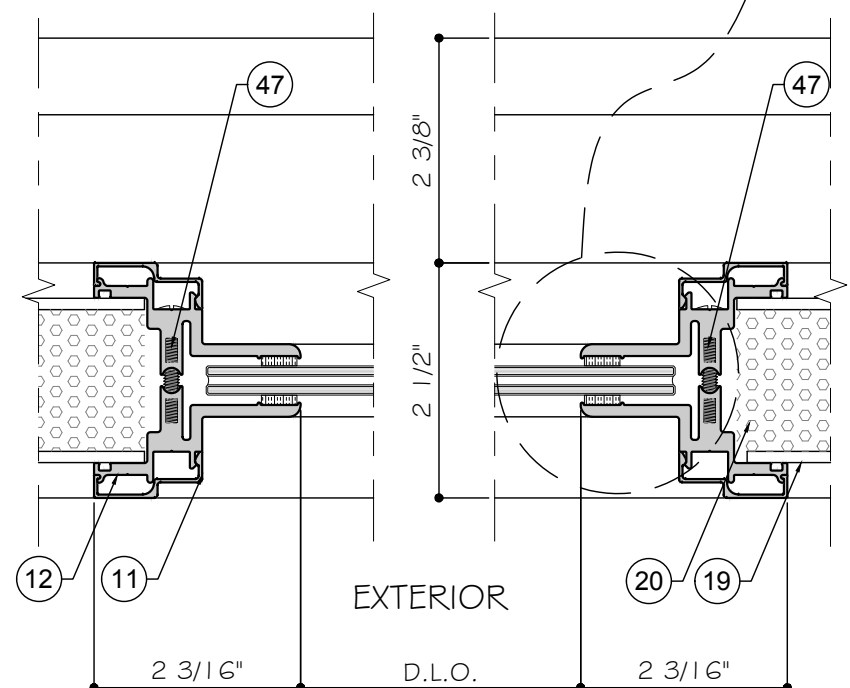

D DETAIL
D3

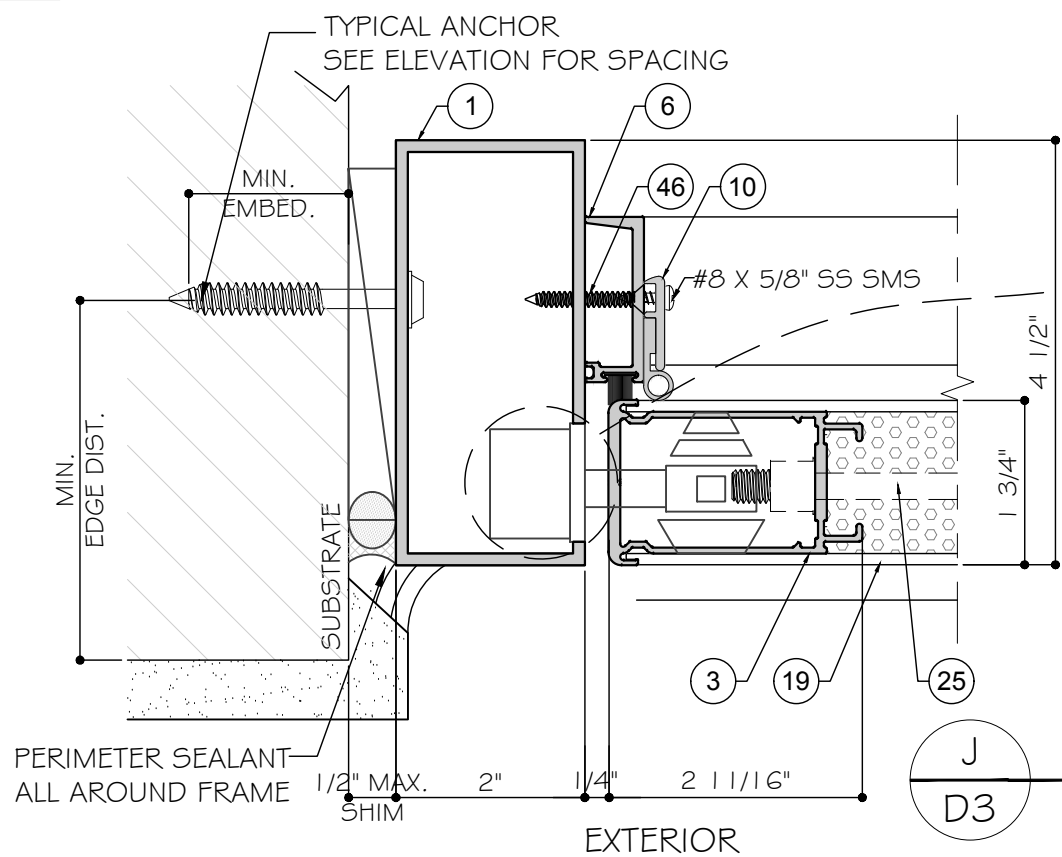

E DETAIL
D3

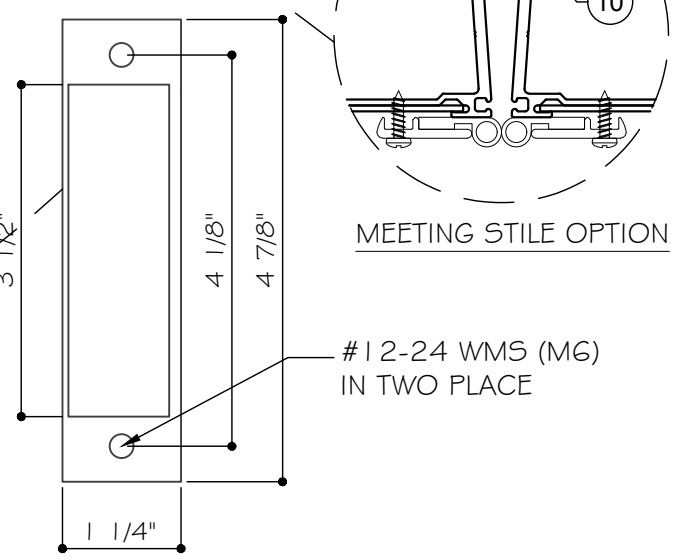

H DETAIL
D3

I DETAIL
D3

J DETAIL
D3

PRODUCT CONTROL APPROVAL

AFISU OLABIMTAN, P.E.
 TEXAS REGISTRATION
 TX #63663

 10-18-18

NO.	DATE	DESCRIPTION

MCY ENGINEERING, INC.
 GLAZING CONSULTANTS
 8501 SW 124 AVE. STE. 205A P: 305.271.0117
 MIAMI, FL. 33183 F: 786.573.5063
 www.MCYUS.com
 MCY.Engineering@Att.net

SPECIAL-LITE, INC.
 ALUMINUM FRAME OUTSWING DOORS
 860 SOUTH WILLIAMS STREET
 P.O. BOX 6
 DECATUR, MI 49045
 WWW.SPECIAL-LITE.COM



D3

DATE	10/19/18
SCALE	AS SHOWN
DRAWN	T.G.
PROJECT	17-047
DRAWING NO.	TA17-01
7 OF 13	

APPROVED CONFIGURATIONS AND HARDWARE

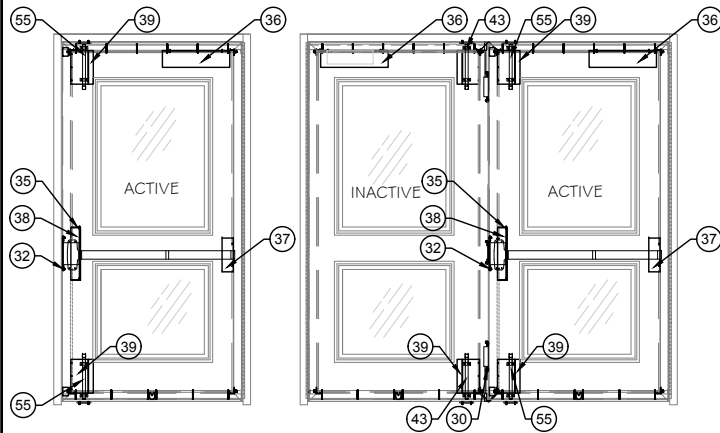

OPTION 1
LOCK:
 ACTIVE PANEL: VON DUPRIN MORTISE LOCK 9975EO @ 39" FROM BOTTOM

SURFACE BOLT
 INACTIVE PANEL: IVES SB360 W/ MORTISE STRIKE
 ACTIVE PANEL: ABH HD1825 W/ MORTISE STRIKE
 ENGAGEMENT: 13/16" @ THRESHOLD AND 5/8" @ FRAME HEAD.

FLUSH BOLT:
 INACTIVE PANEL: IVES 458
 ENGAGEMENT: 9/16" @ THRESHOLD AND FRAME HEAD

DOOR CLOSER: ALLEGION LCN 4040 SERIES

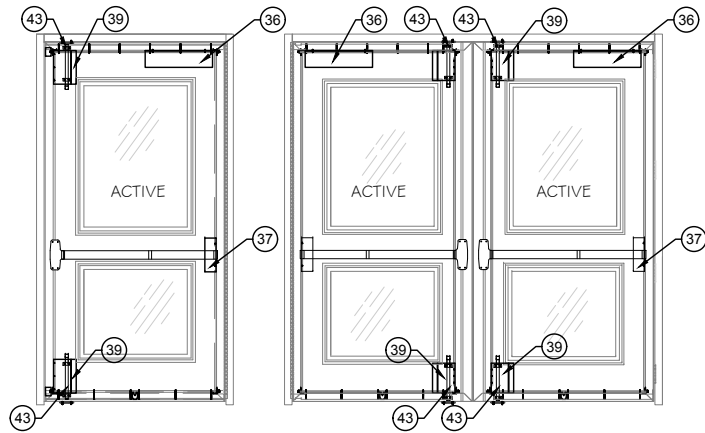

OPTION 2
LOCK:
 ACTIVE PANEL: VON DUPRIN CVR 9947EO PANIC DEVICE W/ 2 POINT LOCK SYSTEM.

SURFACE BOLTS:
 ACTIVE PANEL: IVES SB360 W/ MORTISE STRIKE
 ENGAGEMENT: 13/16" @ THRESHOLD AND 9/16" @ FRAME HEAD.

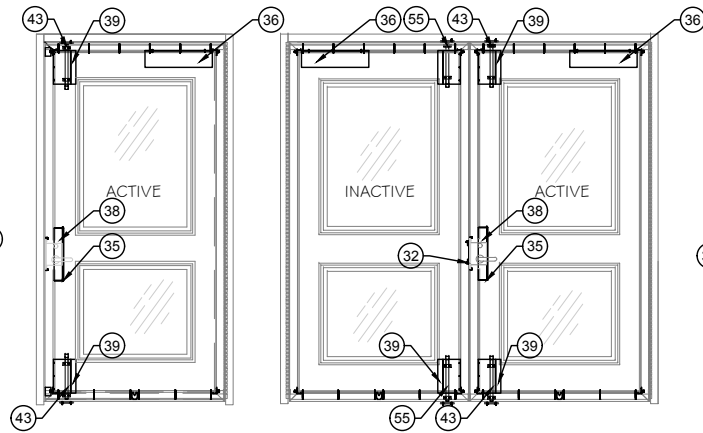

OPTION 3
LOCK:
 ACTIVE PANEL: SCHLAGE L9453P SERIES MORTISE LOCK AND DEADBOT

SURFACE BOLTS:
 INACTIVE PANEL: ABH SURFACE BOLTS
 ACTIVE PANEL: IVES SB360
 ENGAGEMENT: 15/16" @ THRESHOLD AND 7/8" @ FRAME HEAD.

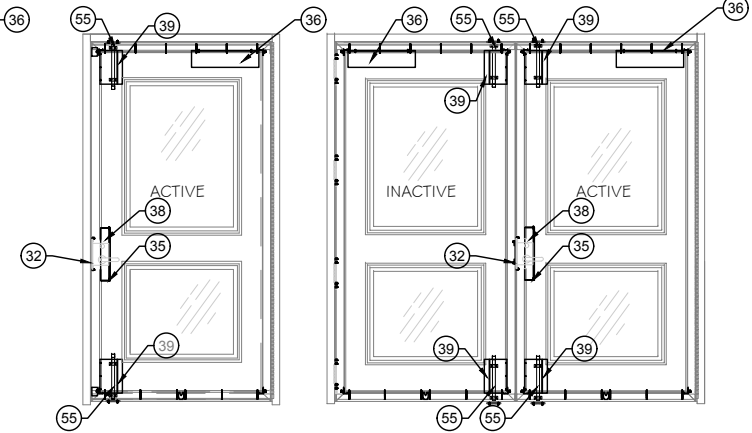

OPTION 4
LOCK:
 ACTIVE PANEL: DORMA MORTISE LOCK SL11 HD WITH SURFACE MOUNT STRIKE PLATE

SURFACE BOLTS:
 INACTIVE PANEL: ABH SURFACE BOLTS HD1825
 ACTIVE PANEL: ABH SURFACE BOLTS HD1825
 ENGAGEMENT: 13/16" @ THRESHOLD AND 5/8" @ FRAME HEAD.

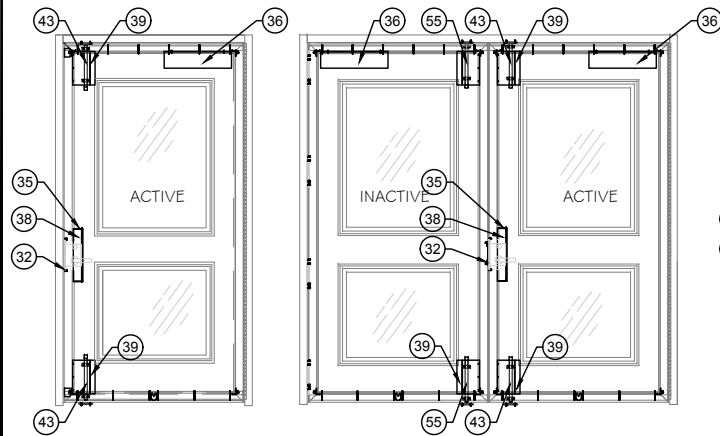

OPTION 5
LOCK:
 ACTIVE PANEL: DESIGN HARDWARE MORTISE LOCK AND DEADBOLT AT 39 1/4" FROM BOTTOM

SURFACE BOLT:
 INACTIVE PANEL: ABH HD1825
 ACTIVE PANEL: IVES SB360
 ENGAGEMENT: 13/16" @ THRESHOLD AND 9/16" @ FRAME HEAD.

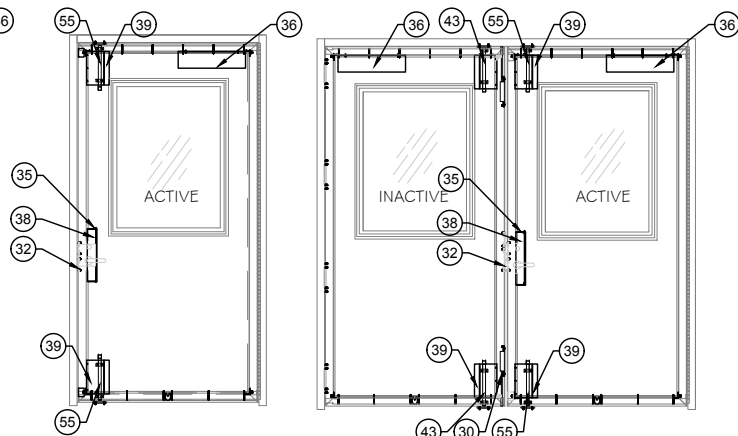

OPTION 6
LOCK:
 ACTIVE PANEL: DESIGN HARDWARE CYLINDRICAL LOCK Z SERIES AT 39 3/4" FROM BOTTOM

SURFACE BOLT:
 INACTIVE PANEL: IVES SB360 W/ ABH FLUSH BOLTS
 ACTIVE PANEL: ABH HD1825
 ENGAGEMENT: 13/16" @ THRESHOLD AND 9/16" @ FRAME HEAD.

FLUSH BOLTS
 INACTIVE: ABH 1855 @ 12" FROM ENDS
 ENGAGEMENT: 9/16" @ THRESHOLD & HEAD.

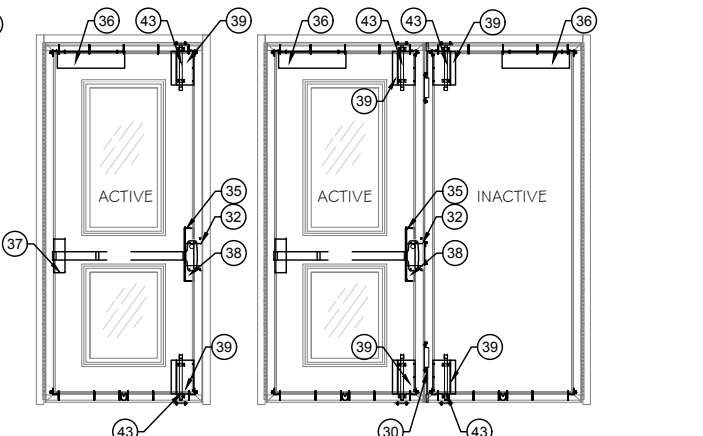

OPTION 7
LOCK:
 ACTIVE PANEL: SECURITECH EXIT PANIC DEVICE AT 39" FROM BOTTOM

SURFACE BOLT:
 ACTIVE PANEL: IVES SB360
 INACTIVE PANEL: IVES SB360
 ENGAGEMENT: 13/16" @ THRESHOLD AND 5/8" AT FRAME HEAD

FLUSH BOLTS
 ACTIVE PANEL: IVES 458
 ENGAGEMENT: 13/16" @ THRESHOLD AND 5/8" @ FRAME HEAD.

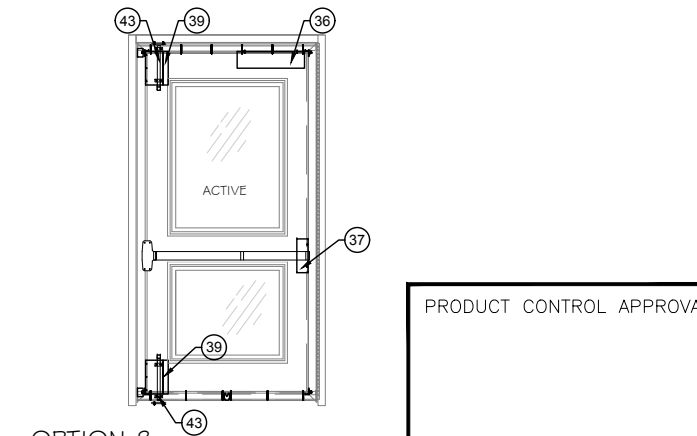

OPTION 8
LOCK:
 ACTIVE PANEL: DORMA 9954 MORTISE LOCK W/ LEVER HANDLE AND DEADBOLT @ 38" FROM BOTTOM

SURFACE BOLTS:
 ACTIVE PANEL: IVES SB360
 SURFACE BOLTS
 ENGAGEMENT: 1/2" @ THRESHOLD AND 13/16" @ FRAME HEAD.

PRODUCT CONTROL APPROVAL

AFISU OLABIMTAN, P.E.
 TEXAS REGISTRATION
 TX #63663



NO.	DATE	DESCRIPTION

MCY ENGINEERING, INC.
 GLAZING CONSULTANTS

8501 SW 124 AVE. STE. 205A P: 305.271.0117
 MIAMI, FL. 33183 F: 786.573.5063
 www.MCYUS.com
 MCY.Engineering@Att.net

SPECIAL-LITE, INC.
 ALUMINUM FRAME OUTSWING DOORS

860 SOUTH WILLIAMS STREET
 P.O. BOX 6
 DECATUR, MI 49045
 WWW.SPECIAL-LITE.COM

Special-Lite
 Doors with more life.

DATE	10/15/18
SCALE	AS SHOWN
DRAWN	T.G.
PROJECT	17-047
DRAWING NO.	TA17-01
8 OF 13	

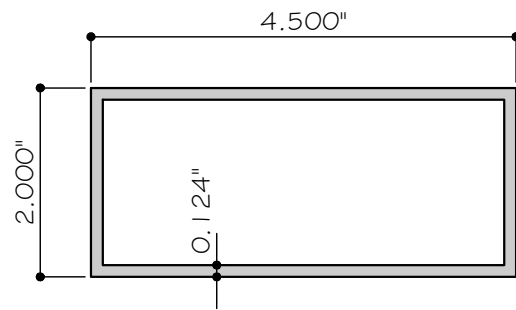

① T-8 FRAME HEAD AND JAMB
ALUM. 6063-T6

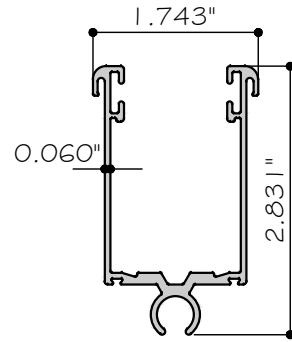

② 70-2A TOP/BOTTOM RAIL
ALUM. 6063-T6

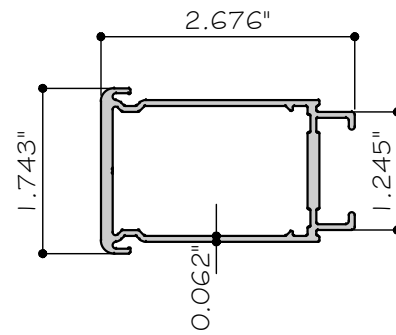

③ 70-1A FRAME HINGE STILE
ALUM. 6063-T6

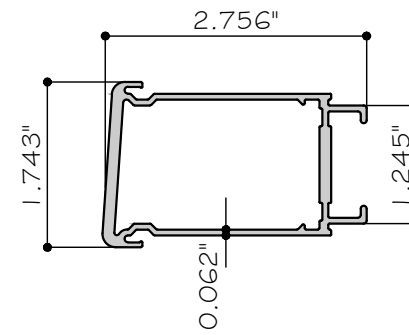

④ 70-91A FRAME LOCK STILE
ALUM. 6063-T6

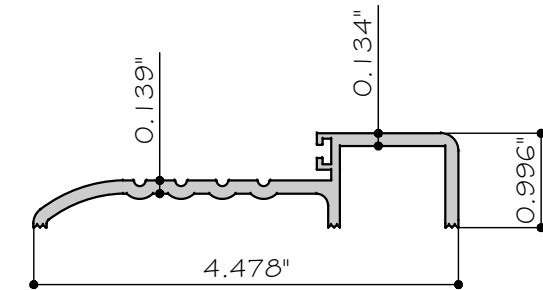

⑤ 561 THRESHOLD
ALUM. 6063-T6

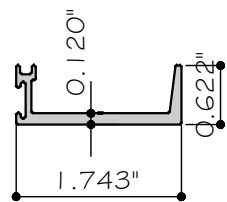

⑥ DS-33 DOOR STOP
ALUM. 6063-T6

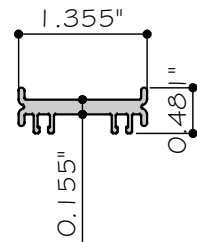

⑦ 70-52 SWEEP STRIP BAR
ALUM. 6063-T6

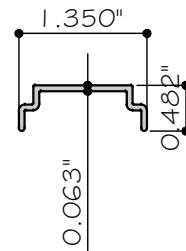

⑧ 70-53 COVER CAP
ALUM. 6063-T6

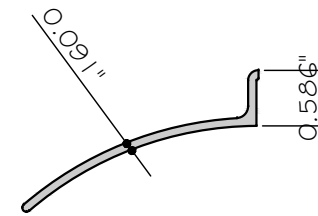

⑨ 142 RAIN DRIP
ALUM. 6063-T6

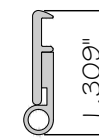

⑩ 328 DOOR SEAL
ALUM. 6063-T6

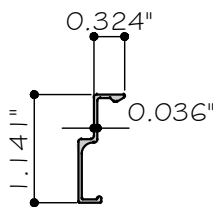

⑪ 70-800 LITE KIT SNAP COVER
ALUM. 6063-T6

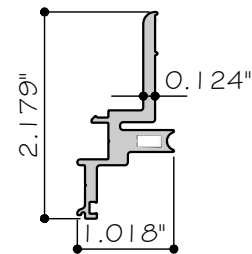

⑫ 70-802 5/16" LITE KIT
ALUM. 6063-T6

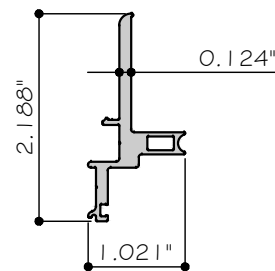

⑬ 70-801 1" LITE KIT
ALUM. 6063-T6

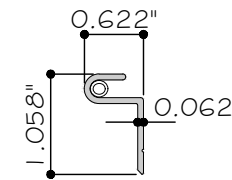

⑭ 123NA WATER SHED
ALUM. 6063-T6

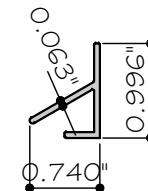

⑮ 124A WATER SHED
ALUM. 6063-T6

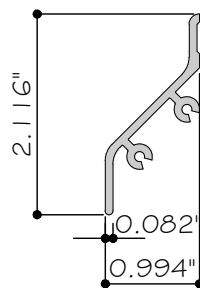

⑯ 141 RAIN DRIP
ALUM. 6063-T6

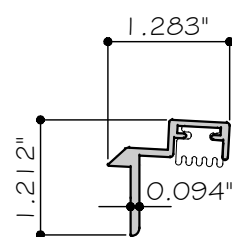

⑰ 1840 ASTRAGAL
ALUM. 6063-T6

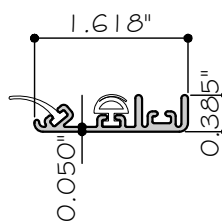

⑱ 383 MEETING STILE
ALUM. 6063-T6

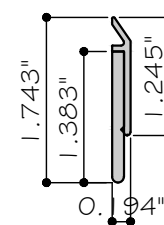

⑲ 39 DOOR SWEEP
ALUM. 6063-T6

PRODUCT CONTROL APPROVAL

AFISU OLABIMTAN, P.E.
TEXAS REGISTRATION
TX #63663



10-18-18

NO.	DATE	DESCRIPTION

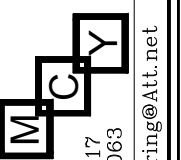

MCY ENGINEERING, INC.
GLAZING CONSULTANTS
8501 SW 124 AVE. STE. 205A P: 305.271.0117
MIAMI, FL. 33183 F: 786.573.5063
www.MCYUS.com

SPECIAL-LITE, INC.
860 SOUTH WILLIAMS STREET
P.O. BOX 6
DECATUR, MI 49045
WWW.SPECIAL-LITE.COM



PARTS

DATE	10/19/18
SCALE	AS SHOWN
DRAWN	T.G.
PROJECT	17-047

DRAWING NO.
TA17-01

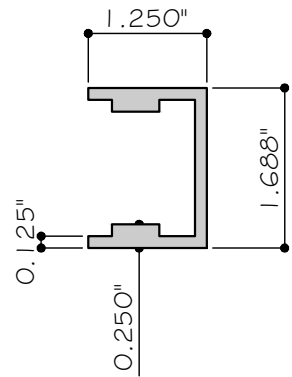

31 FRAME CORNER CLIP
ALUM. 6061-T6

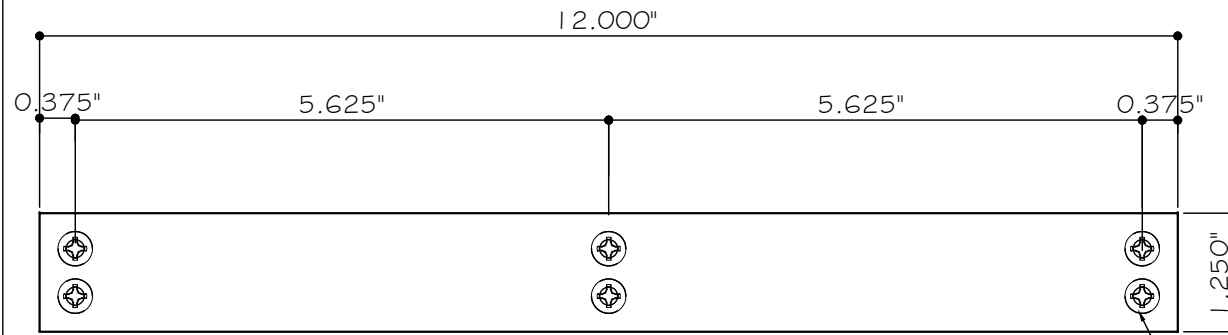

40 1 1/4" X 1/2" X 12" LG. ALUM. BAR REINF.
PT-8001 ALUM. 6061-T6

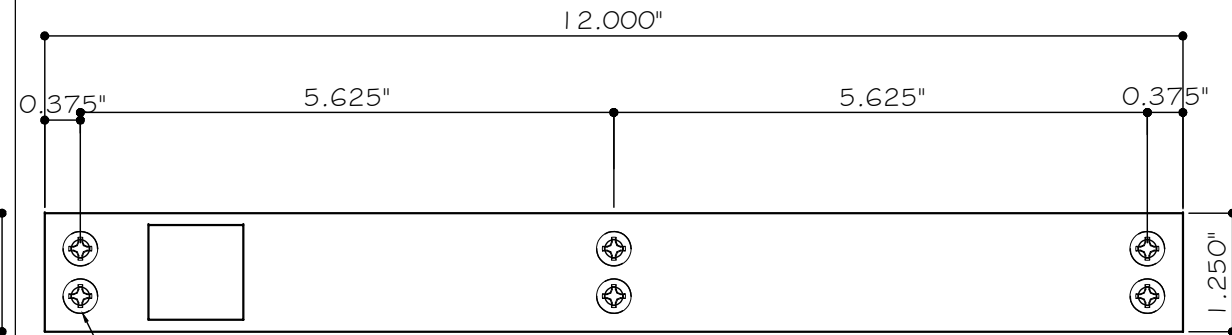

41 1 1/4" X 1/2" X 12" LG. ALUM. BAR REINF.
PT-8002 ALUM. 6061-T6

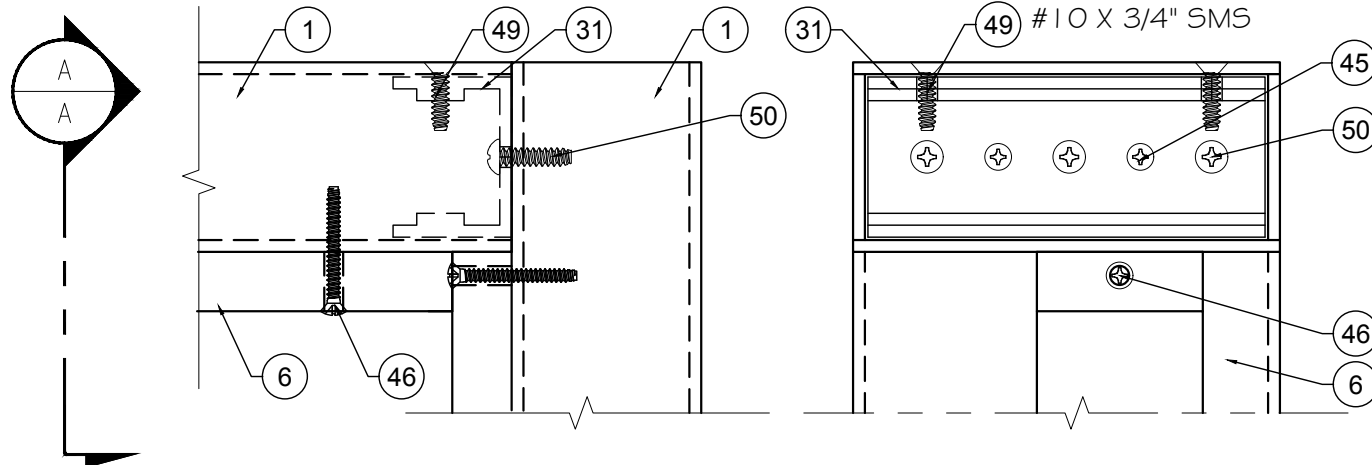

J T8-CORNER DETAIL
10

SECTION A-A

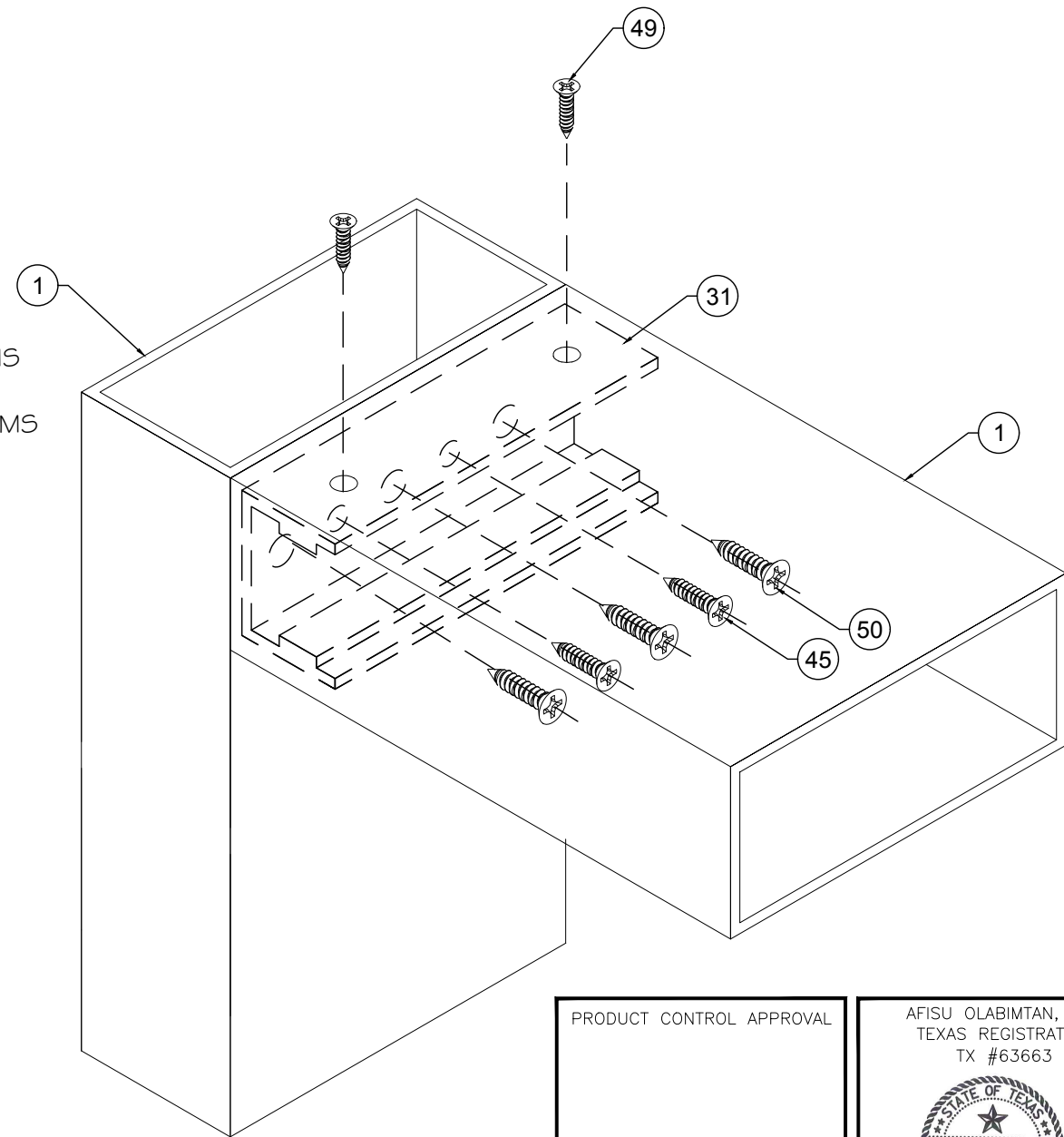

CORNER CONNECTION DETAIL

PRODUCT CONTROL APPROVAL

AFISU OLABIMTAN, P.E.
TEXAS REGISTRATION
TX #63663

NO.	DATE	DESCRIPTION

MCY
MCY ENGINEERING, INC.
GLAZING CONSULTANTS
8501 SW 124 AVE. STE. 205A P: 305.271.0117
MIAMI, FL. 33183 F: 786.573.5063
www.MCYUS.com
www.MCYEngineering@Att.net

SPECIAL-LITE, INC.
ALUMINUM FRAME OUTSWING DOORS
860 SOUTH WILLIAMS STREET
P.O. BOX 6
DECATUR, MI 49045
WWW.SPECIAL-LITE.COM



PARTS	
DATE	10/19/18
SCALE	AS SHOWN
DRAWN	T.G.
PROJECT	17-047
DRAWING NO.	TA17-01
10 OF 13	

BILL OF MATERIALS

ITEM	PART	DESCRIPTION	MATERIAL	MANUFACTURER / REMARKS
1	T-8	2" X 4.5" CLASS 1 ANODIZED ALUMINUM HEAD/JAMB FRAME	ALUM. 6063-T6	SPECIAL-LITE, INC.
2	70-2A	TOP/BOTTOM RAIL	ALUM. 6063-T6	SPECIAL-LITE, INC.
3	70-1A	HINGE STILE	ALUM. 6063-T6	SPECIAL-LITE, INC.
4	70-91A	LOCK STILE	ALUM. 6063-T6	SPECIAL-LITE, INC.
5	561	THRESHOLD	ALUM. 6063-T6	ZERO INTERNATIONAL
6	D5-33	DOOR STOP	ALUM. 6063-T6	SPECIAL-LITE, INC.
7	70-52	SWEEP STRIP BAR	ALUM. 6063-T6	SPECIAL-LITE, INC.
8	70-53	COVER CAP	ALUM. 6063-T6	SPECIAL-LITE, INC.
9	142	RAIN DRIP	ALUM. 6063-T6	ZERO INTERNATIONAL
10	328	DOOR SWEEP W/ SOLID NEOPRENE	ALUM. 6063-T6 & NEOPRENE	ZERO INTERNATIONAL, ATTACHED W/ #6 X 1/2" SMS
11	70-800	LITE KIT SNAP COVER	ALUM. 6063-T6	SPECIAL-LITE, INC.
12	70-802	LITE KIT 5/16" GLASS	ALUM. 6063-T6	SPECIAL-LITE, INC.
13	70-801	LITE KIT 1" GLASS	ALUM. 6063-T6 & NEOPRENE	ZERO INTERNATIONAL, ATTACHED W/ #6 X 1/2" SMS
14	123NA	WATER SHED	ALUM. 6063-T6	NATIONAL GUARD
15	124A	WATER SHED	ALUM. 6063-T6	NATIONAL GUARD
16	141	RAIN DRIP	ALUM. 6063-T6	ZERO INTERNATIONAL
17	1840	ASTRAGAL WITH NEOPRENE	ALUM. 6063-T6 & NEOPRENE	ZERO INTERNATIONAL
18	383	MEETING STILE WITH NEOPRENE	ALUM. 6063-T6 & NEOPRENE	ZERO INTERNATIONAL
19	-	0.120" PEBBLE FRP SKIN	FRP	SPECIAL-LITE, INC.
	-	0.0625" ALUM. SKIN	-	CRANE COMPOSITES
	-	0.120" SANDSTONE FRP SKIN	FRP	SPECIAL-LITE, INC.
	-	0.125" ALUMINUM SKIN	-	CRANE COMPOSITES
	-	0.120" AMP SKIN	AMP	MASTERGRAIN
20	-	POURED IN PLACE URETHANE FOAM OR EQUIVALENT	URETHANE FOAM	SPECIAL-LITE, INC.
21	RE-58	CORNER CLIP	ALUM. 6061-T6	SPECIAL-LITE, INC.
22	RE-148	1 7/16" X 1 3/8" X 1/8" THK. X 47 5/8" LG. ALUM. CLIP REINFORCEMENT	ALUM. 6061-T6	SPECIAL-LITE, AT TOP/BOTTOM RAIL
23	8634-5771-1	WEATHER STRIP	POLYPROPYLENE & WOVEN PILE	SCHLEGEL SYSTEMS
24	ZSP2110-002	RUBBER GASKET	EPDM RUBBER	TOTAL PLASTIC
25	-	3/8"-16 STEEL TIE ROD	STEEL	-
26	FMHD95AL	CONTINUOUS HINGE	ALUM. 6063-T6	DESIGN HARDWARE, (15) 1/4"-20 X 1/2" FH SMS ATTACHED TO FRAME AND PANEL.
27	AI10HD	ABH CONTINUOUS HINGE	ALUM. 6063-T6	ABH, (15) 1/4"-20 X 1/2" FH SMS ATTACHED TO FRAME AND PANEL.
28	PT-8003	1" X 0.855" X 16" LG. ALUMINUM BAR REINFORCEMENT	ALUM. 6061-T6	(1) INSIDE THE THRESHOLD LOCATED AT 4" FROM LEFT.
29	39	DOOR SWEEP	ALUM. 6063-T6 & NEOPRENE	ZERO INTERNATIONAL
30	PT-519	EXTRUDED ALUMINUM REINFORCEMENT	ALUM. 6061-T6	(1) INSIDE THE INACTIVE PANEL ABOVE AND BELOW EACH FLUSH BOLT.
31	PT-131	FRAME CORNER CLIP	ALUM. 6061-T6	SPECIAL-LITE, INC.
32	PT-514	ONE EXTRUDED ALUMINUM BAR REINFORCEMENT	ALUM. 6061-T6	INSIDE THE ACTIVE PANEL ABOVE AND BELOW THE LOCK
33	SL11HD	DORMA MORTISE LOCK @ 39 3/4" FROM BOTTOM	STEEL	DORMA
35	PT-300	TWO-PIECE EXTRUDED ALUM. LOCK REINFORCEMENT	ALUM. 6063-T6	(1) INSIDE THE ACTIVE PANEL LOCK STILE @ THE PANIC DEVICE LOCATION, W/(1) #8X5/8" PH SMS
36	PT-306	4 1/2" X 1/2" X 1/8" X 17 1/2" LG. ALUM. ANGLE REINFORCEMENT	ALUM. 6063-T6	(1) INSIDE THE LEFT SIDE OF THE LEFT PANEL TOP RAIL ON THE INT. AND EXT. AND INSIDE THE RIGHT SIDE OF THE RIGHT PANEL TOP RAIL ON THE INT. AND EXT.
37	PT-304	ALUMINUM PLATE REINFORCEMENT	ALUM. 6063-T6	(1) INSIDE THE HINGE STILE @ PANIC DEVICE LOCATION

PRODUCT CONTROL APPROVAL

AFISU OLABIMTAN, P.E.
TEXAS REGISTRATION
TX #63663



REVISIONS	
NO.	DESCRIPTION

MCY

MCY ENGINEERING, INC.
GLAZING CONSULTANTS

8501 SW 124 AVE. STE. 205A P: 305.271.0117
MIAMI, FL. 33183 F: 786.573.5063
www.MCYUS.com

ALUMINUM FRAME OUTSWING DOORS

SPECIAL-LITE, INC.
860 SOUTH WILLIAMS STREET
P.O. BOX 6
DECATUR, MI 49045
WWW.SPECIAL-LITE.COM



B.O.M.	
DATE	09/19/18
SCALE	AS SHOWN
DRAWN	T.G.
PROJECT	17-047
DRAWING NO. AD17-01	
11 OF 13	

BILL OF MATERIALS (CONT.)

ITEM	PART	DESCRIPTION	MATERIAL	MANUFACTURER / REMARKS
38	PT-317	TWO-PIECE EXTRUDED ALUM. LOCK REINFORCEMENT	ALUM. 6063-T6	(1) INSIDE THE ACTIVE PANEL LOCK STILE @ THE PANIC DEVICE LOCATION, W/(1) #8X5/8" PH SMS
39	PT-8000	ONE EXTRUDED ALUMINUM REINFORCEMENT	ALUM. 6063-T6	INSIDE THE ACTIVE AND INACTIVE PANEL LOCK STILE AT TOP AND BOTTOM
40	PT-8001	1/4" x 1/2" x 12" LG. ALUMINUM BAR REINFORCEMENT	ALUM. 6061-T6	(1) AT THE FRAME HEAD INSIDE THE DOOR STOP LOCATED 12" AND 91" FROM LEFT.
41	PT-8002	1/4" x 1/2" x 12" LG. ALUMINUM BAR REINFORCEMENT	ALUM. 6061-T6	(1) AT THE FRAME HEAD INSIDE THE DOOR STOP, LOCATED AT 41" AND 61 1/2" FROM LEFT
42	9975EO	MORTISE LOCK DEVICE @ 39" FROM BOTTOM	STEEL	VON DUPRIN, (2) 12"-24 X 1/2" F.H. SMS, (4) 10"-24 X 1" P.H. SMS & (2) 10"-24" X 1" F.H. SMS
43	SB360	IVES SURFACE BOLTS	STEEL	IVES, 6" FROM ENDS W/ (1) 2" X 1/2" X 7/8" ALUM. PLATE & (2) 1/4"-20 X 3" F.H. SMS
44	SC-1	6 X 3/8" PHILIPS F.H. SMS	STEEL	SPECIAL - LITE
45	SC-12	8 X 5/8" PHILIPS P.H. SMS	STEEL	-
46	SC-15	8 X 1 3/8" PHILIPS F.H. SMS @ EA. END# 11" MAX. O.C.	STEEL	-
47	SC-17	8 X 1/4" PHILIPS OVAL HEAD SMS	STEEL	-
48	SC-22	10 X 2 1/2" PHILLIPS F.H. SMS	STEEL	-
49	SC-23	10 X 3/4" PHILLIPS F.H. SMS	STEEL	-
50	SC-25	10 X 3/4" PHILLIPS TRUSS HEAD SMS	STEEL	-
51	SC-26	12-24 X 1/2" PHILLIPS U/C F.H. CLR	STEEL	-
52	SC-28	12-24 X 1" PHILLIPS F.H. CLR	STEEL	-
53	71TS1-F13E-630	SECURITECH EXIT DEVICE	STAINLESS STEEL	SECURITECH
54	9947EO	SURFACE MOUNT METALLIC PANIC DEVICE	ALUM. 6063-T6	VON DUPRIN
55	HD1825	ABH SURFACE BOLTS	STAINLESS STEEL	ABH
56	BB5	BALL BEARING HINGE @ 7 1/2", 34 1/2", 62" & 88 3/4" FROM BOTTOM	STEEL	DESIGN HARDWARE, (4) 12"-24 X 1/2" F.H. SMS TO FRAME AND PANEL
57	SL-11HD	SELECT PRODUCTS CONTINUOUS HINGE	ALUM. 6063-T6	SELECT PRODUCTS
58	L9453P	SCHLAGE L SERIES MORTISE LOCK AND DEADBOLT	STEEL	SCHLAGE
59	10-072	STRIKE	STEEL	-
60	Z-SERIES	DESIGN HARDWARE CYLINDRICAL LOCK	STEEL	DESIGN HARDWARE
61	D2	DESIGN HARDWARE DEAD BOLT	STEEL	DESIGN HARDWARE
62	-	SPACER	ALUM.	ALL METAL
63	-	1/8" SETTING BLOCK	EPDM RUBBER, DURO 60 +/- 5 SHORE A	ZATKOFF SEALS AND PACKING
64	-	1/4" SETTING BLOCK	EPDM RUBBER, DURO 60 +/- 5 SHORE A	GLAZING RUBBER PRODUCTS
65	9954	DORMA MORTISE LOCK AND DEADBOLT	STEEL	DORMA

NO.	DATE

MCY ENGINEERING, INC.
GLAZING CONSULTANTS

8501 SW 124 AVE. STE. 205A P: 305.271.0117
MIAMI, FL. 33183 F: 786.573.5063
www.MCYUS.com MCY.Engineering@Att.net

ALUMINUM FRAME OUTSWING DOORS

SPECIAL-LITE, INC.
860 SOUTH WILLIAMS STREET
P.O. BOX 6
DECATUR, MI 49045
WWW.SPECIAL-LITE.COM

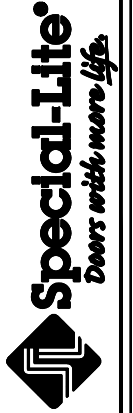

PRODUCT CONTROL APPROVAL

AFISU OLABIMTAN, P.E.
TEXAS REGISTRATION
TX #63663

10-18-18

B.O.M.	
DATE	10/19/18
SCALE	AS SHOWN
DRAWN	T.G.
PROJECT	17-047
DRAWING NO.	
TA17-01	
12 OF 13	

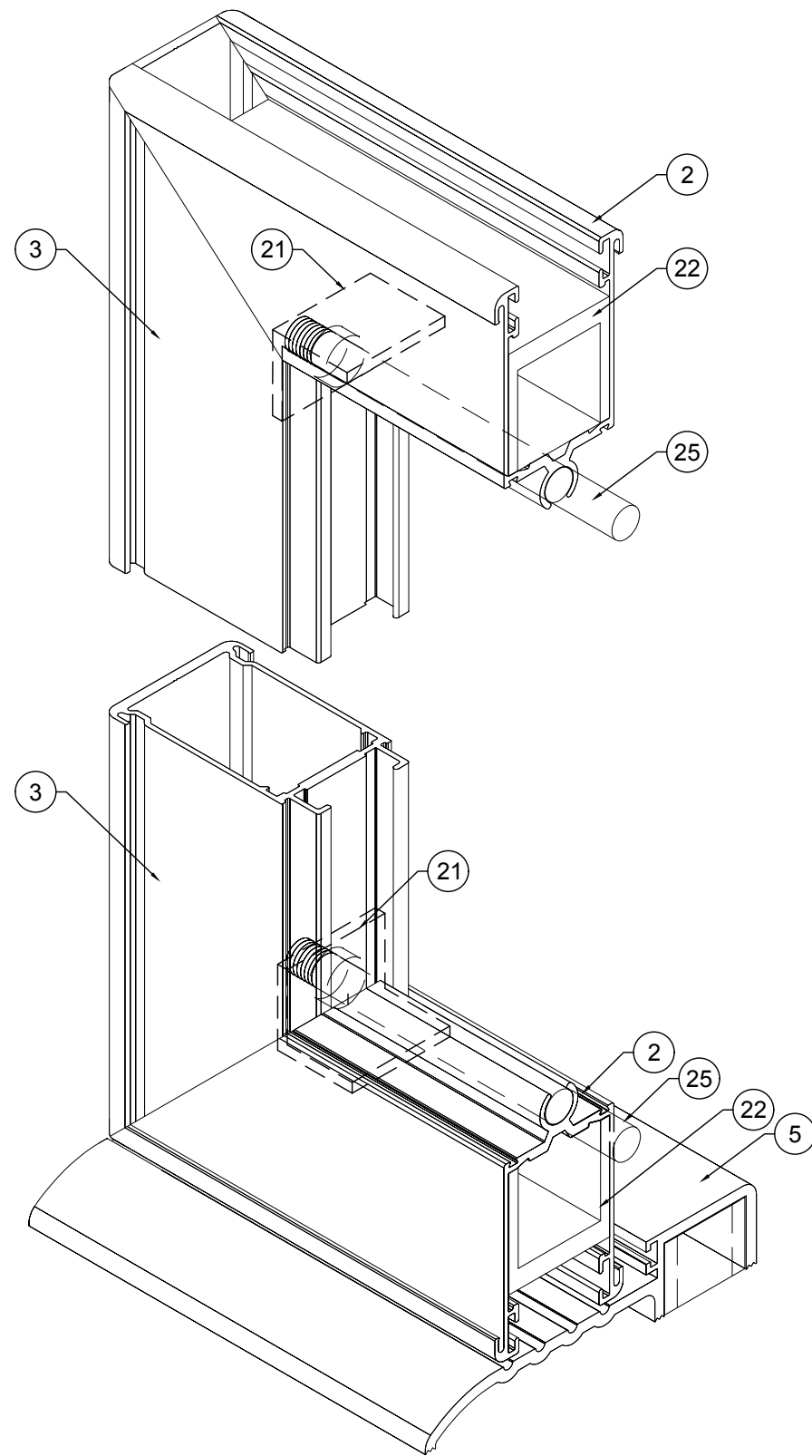

DOOR PANEL CORNER CONNECTION

PRODUCT CONTROL APPROVAL

AFISU OLABIMTAN, P.E.
TEXAS REGISTRATION
TX #63663

PARTS	
DATE	10/19/18
SCALE	AS SHOWN
DRAWN	T.G.
PROJECT	17-047
DRAWING NO. TA17-01	
13 OF 13	

ALUMINUM FRAME OUTSWING DOORS

SPECIAL-LITE, INC.
860 SOUTH WILLIAMS STREET
P.O. BOX 6
DECATUR, MI 49045
WWW.SPECIAL-LITE.COM

MCY ENGINEERING, INC.
GLAZING CONSULTANTS

8501 SW 124 AVE. STE. 205A P: 305.271.0117
MIAMI, FL. 33183 F: 786.573.5063
www.MCYUS.com MCY.Engineering@Att.net

REVISIONS		
NO.	DATE	DESCRIPTION