

Z:\Clients\Therma Tru PERMANENT\B - Texas Dept of Ins\TDI - DR 949 - 6'8 & 8'0 Opaque Comp Edge Coastal Impact w NI Sidelites (TX 4741 - 4744)\C - Drawings\TX-4743-44.dwg

THERMA-TRU[®] DOORS

Fiber-Classic[®] & Smooth-Star[®]

COMPOSITE EDGE OPAQUE FIBERGLASS "COASTAL - IMPACT" SINGLE DOOR w/ "NON-IMPACT" SIDELITE(S) IN SWING/OUT SWING

EVALUATED FOR USE IN THE STATE OF TEXAS

TDI DR-949

The Fiberglass Door system described herein complies with the 2018 International Residential Code (IRC), Sections R301 & R609 and the 2018 International Building Code (IBC), Sections 1404.13, 1609, 1709.5, 2403 and 2404 subject to the following conditions:

1. Anchors shall be as listed and spaced as shown in the details. Anchor embedment to base material shall be beyond wall dressing or stucco.
2. When used in areas requiring wind-borne debris protection, the opaque door does not require impact protection and meets missile level "D" as defined in ASTM E 1996. The sidelites are required to be protected with an impact resistant covering that complies with Section R301.2.1.2 of the IRC and Section 1609.1.2 of the IBC.
3. Allowable design pressure requirements must be equal to or less than the design pressure rating shown in the design pressure chart, sheet 1 of this drawing.
4. Conditions not covered by this drawing are subject to further engineering analysis.
5. Fiber-Classic and Smooth-Star Door and Sidelite panels require the use of "J" part numbers. These door and sidelite panels must be stained or painted within six months of installation.

TABLE OF CONTENTS

SHEET #	DESCRIPTION
1	Typical Elevations, Design Pressures & General Notes
2	Door Panel Details
3	Sidelite Panel Details
4	Elevations
5	Horizontal & Vertical Cross Sections
6	Vertical Cross Sections (Thresholds)
7	Frame Anchoring
8	Hardware Details
9	Glazing Details
10	Components
11	Bill of Materials

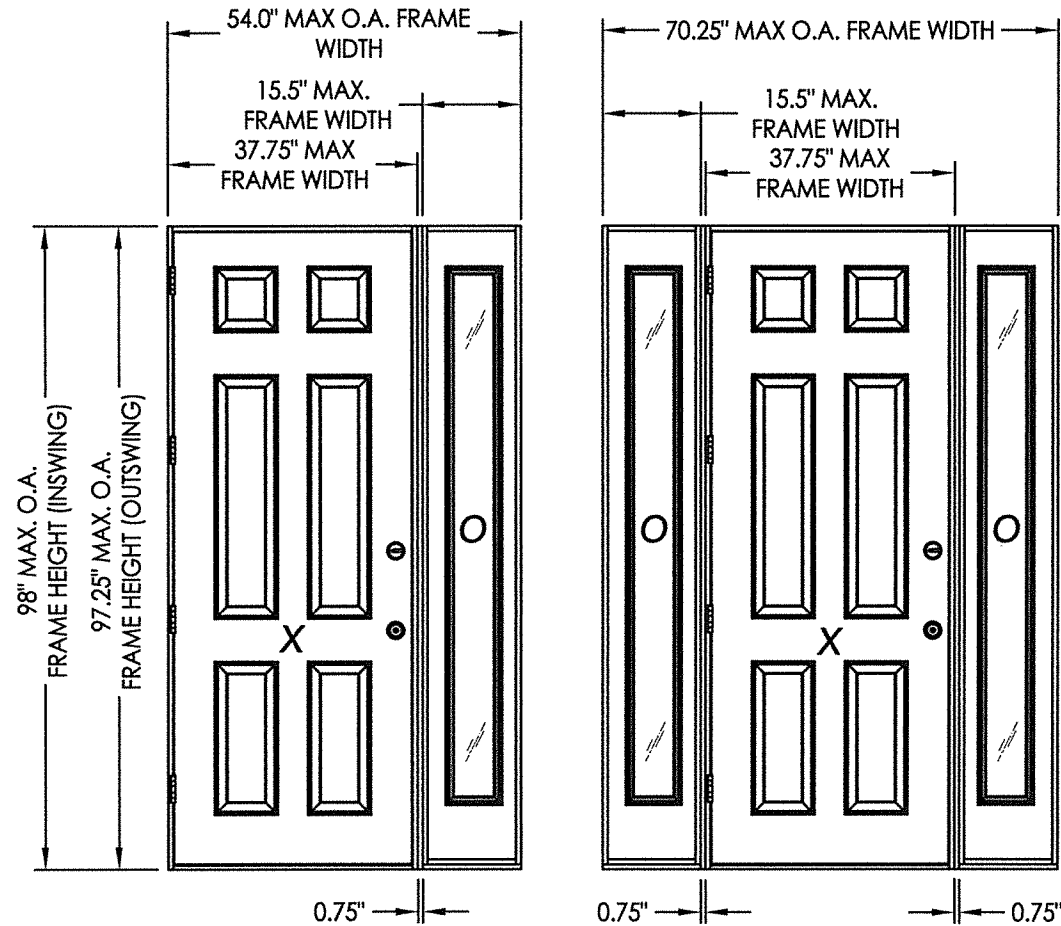

CONFIGURATION	DESIGN PRESSURE (PSF) IN SWING		DESIGN PRESSURE (PSF) OUT SWING	
	POSITIVE	NEGATIVE	POSITIVE	NEGATIVE
XO, OX, OXO	+65.0	-65.0	+65.0	-65.0

See Sheet 4 for Hardware Specifications

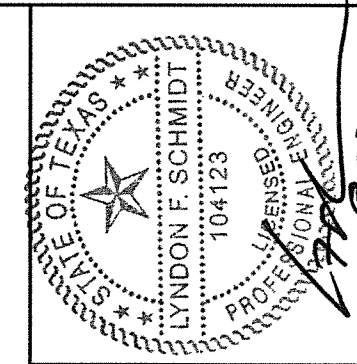

Documents Prepared By: Lyndon F. Schmidt, P.E.
TEXAS P.E. #104123

RW BUILDING CONSULTANTS, INC.
P.O. Box 230 Valrico FL 33595
Phone No.: 813.659.9197

CERTIFICATE OF REGISTRATION # F-11852

PRODUCT: THERMA-TRU
FIBERGLASS DOOR
PART OR ASSEMBLY:
TYPICAL ELEVATION, DESIGN
PRESSURES & GENERAL NOTES

NO.	DATE	DESCRIPTION	BY
1	9/23/21	UPDATE TO 2018 IBC/IRC CODE	LFS

DATE: 11/14/17
SCALE: N.T.S.
DWG. BY: JK
CHK. BY: LFS
DRAWING NO.: TX-4743
SHEET 1 OF 11

© 2017 R.W. BUILDING CONSULTANTS INC.

Z:\Clients\Therma Tru PERMANENT\B - Texas Dept of Ins\TDI - DR 949 - 6'8 & 8'0 Opaque Comp Edge Coastal Impact w NI Sidelites (TX 4741 - 4744)\C - Drawings\TX-4743-44.dwg

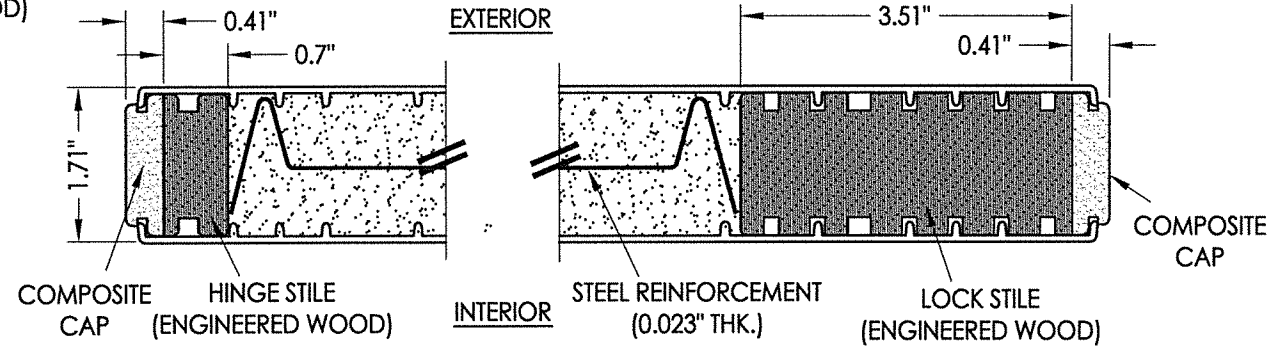
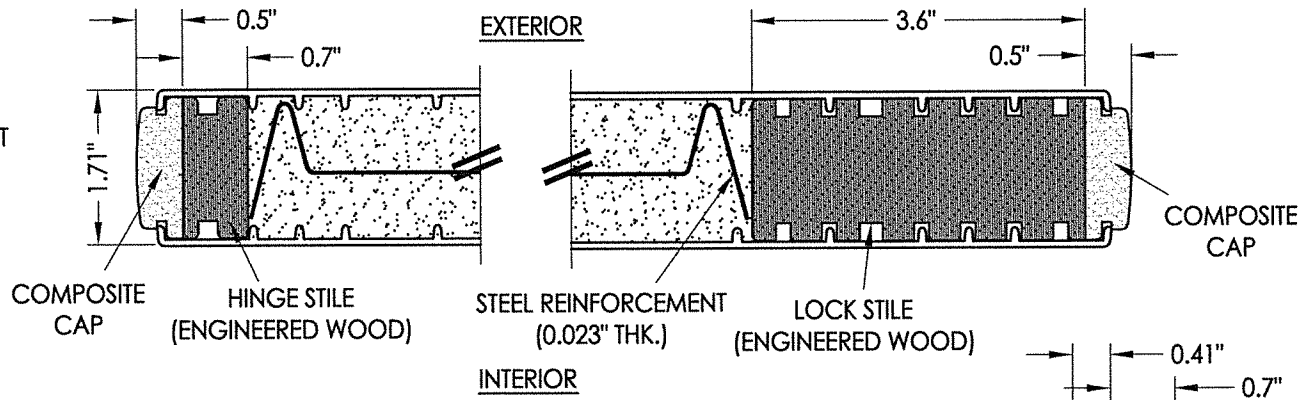
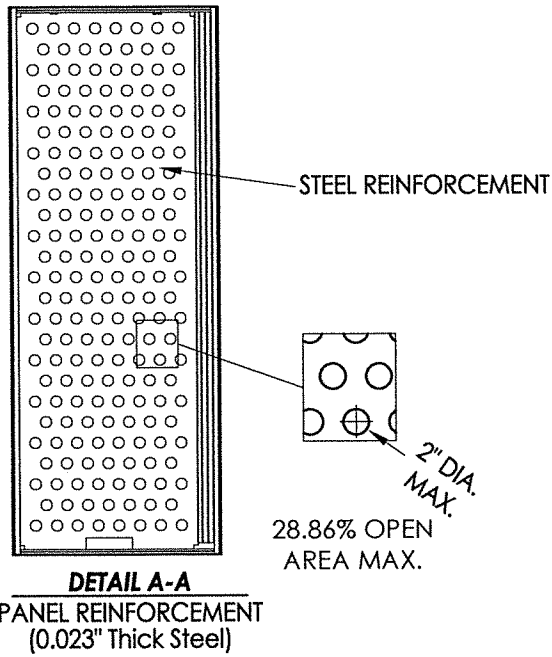

*#8 X 2.5" PFH WS (TYP. @ EACH DOOR CORNER)

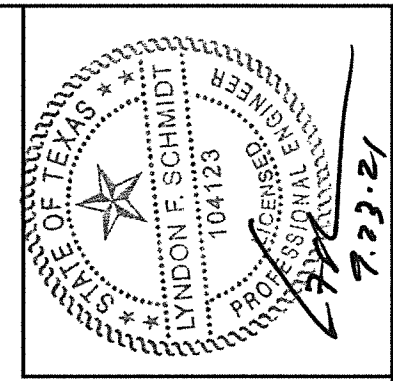
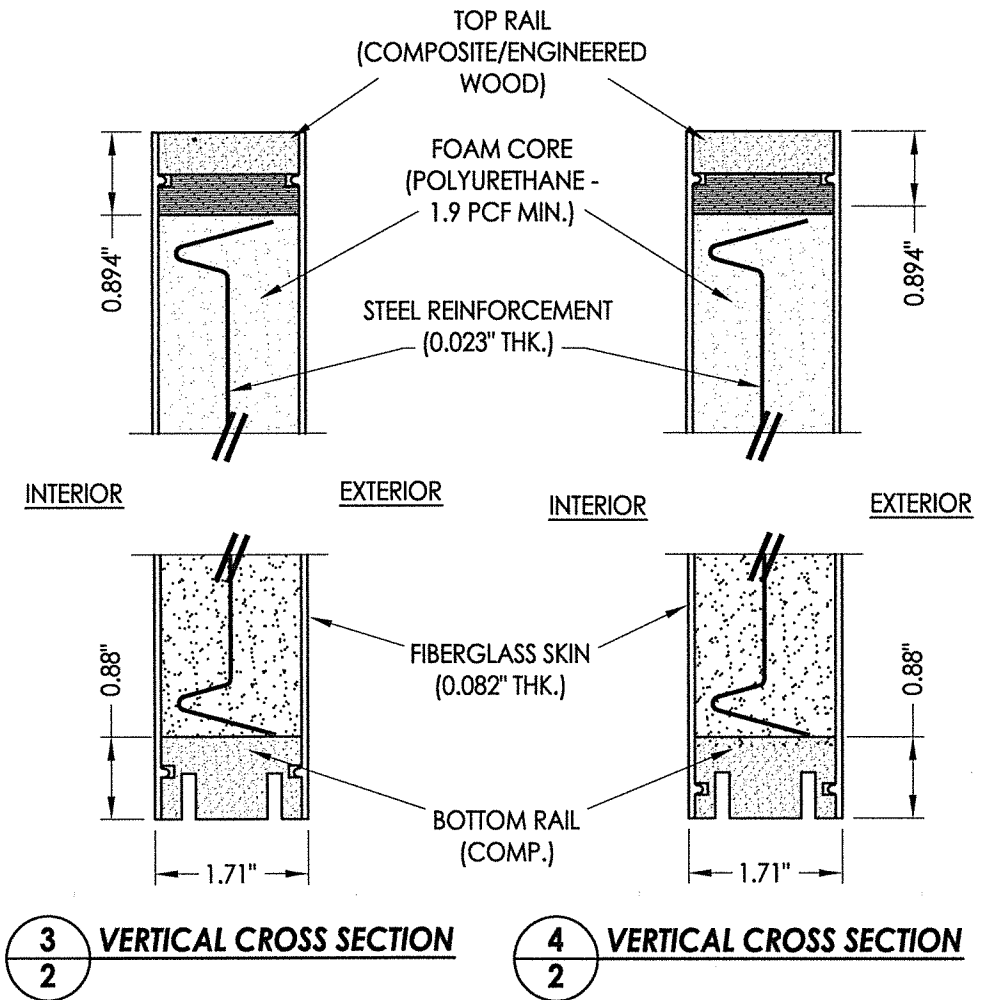
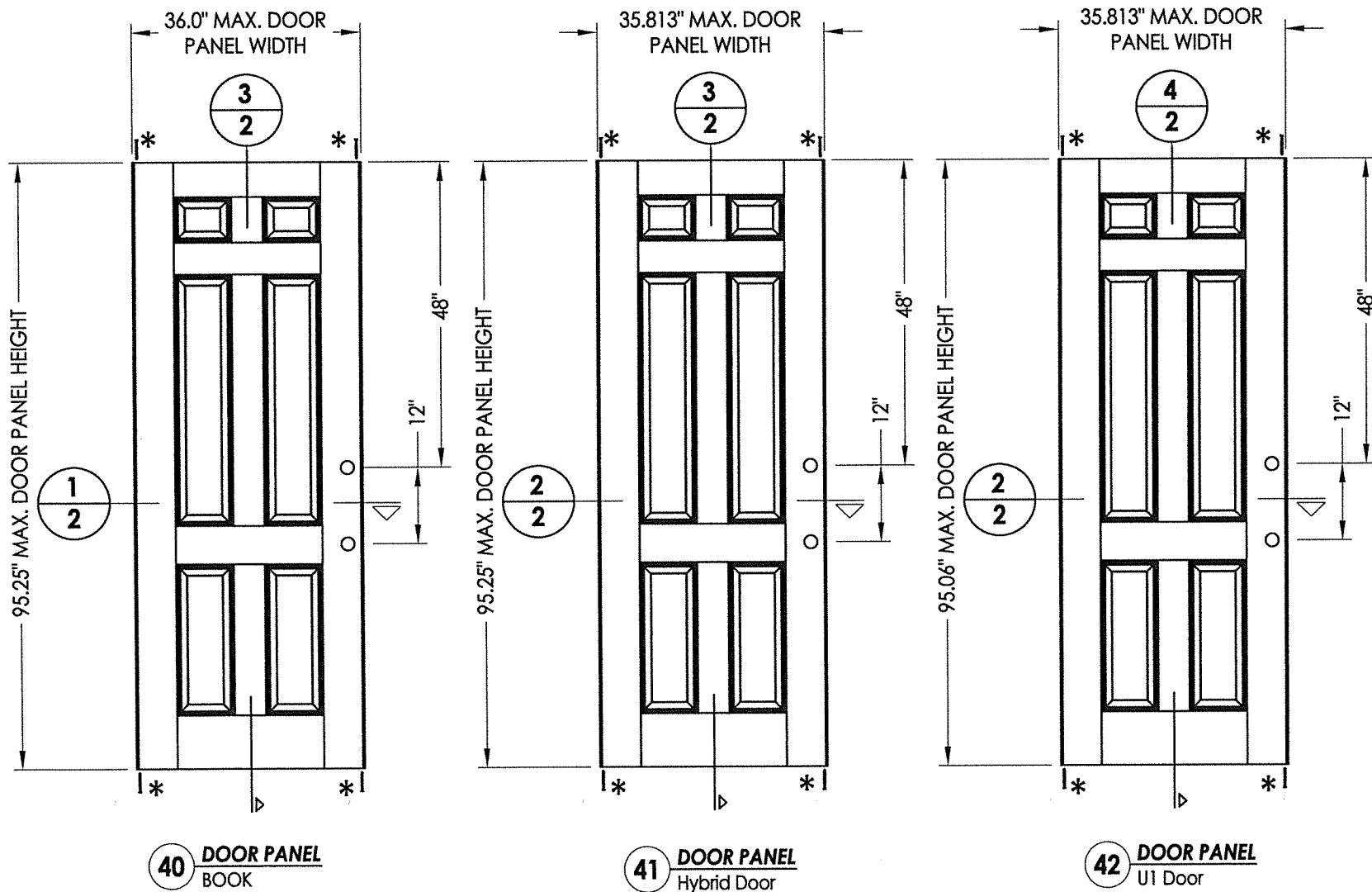

Documents Prepared By: Lyndon F. Schmidt, P.E.
TEXAS P.E. #104123

RW BUILDING CONSULTANTS, INC.
P.O. Box 230 Valrico FL 33595
Phone No.: 813.659.9197

CERTIFICATE OF REGISTRATION # F-11852

PRODUCT: THERMA-TRU FIBERGLASS DOOR

PART OR ASSEMBLY: DOOR PANEL DETAILS

NO.	DATE	REVISIONS	LFS	BY
1	9/23/21	UPDATE TO 2018 IBC/IRC CODE	LFS	

DATE: 11/14/17

SCALE: N.T.S.

DWG. BY: JK

CHK. BY: LFS

DRAWING NO.: TX-4743

SHEET 2 OF 11

© 2017 R.W. BUILDING CONSULTANTS INC.

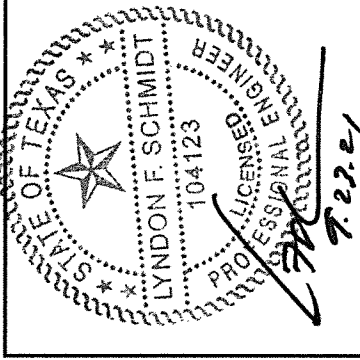
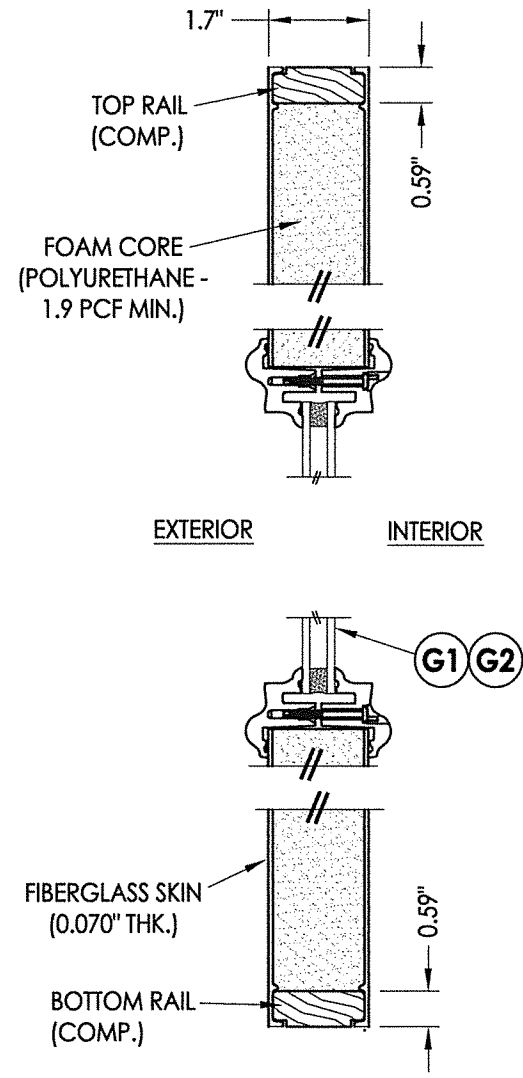
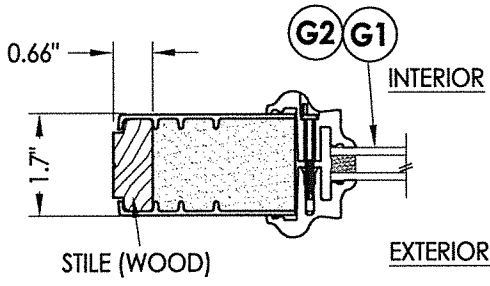
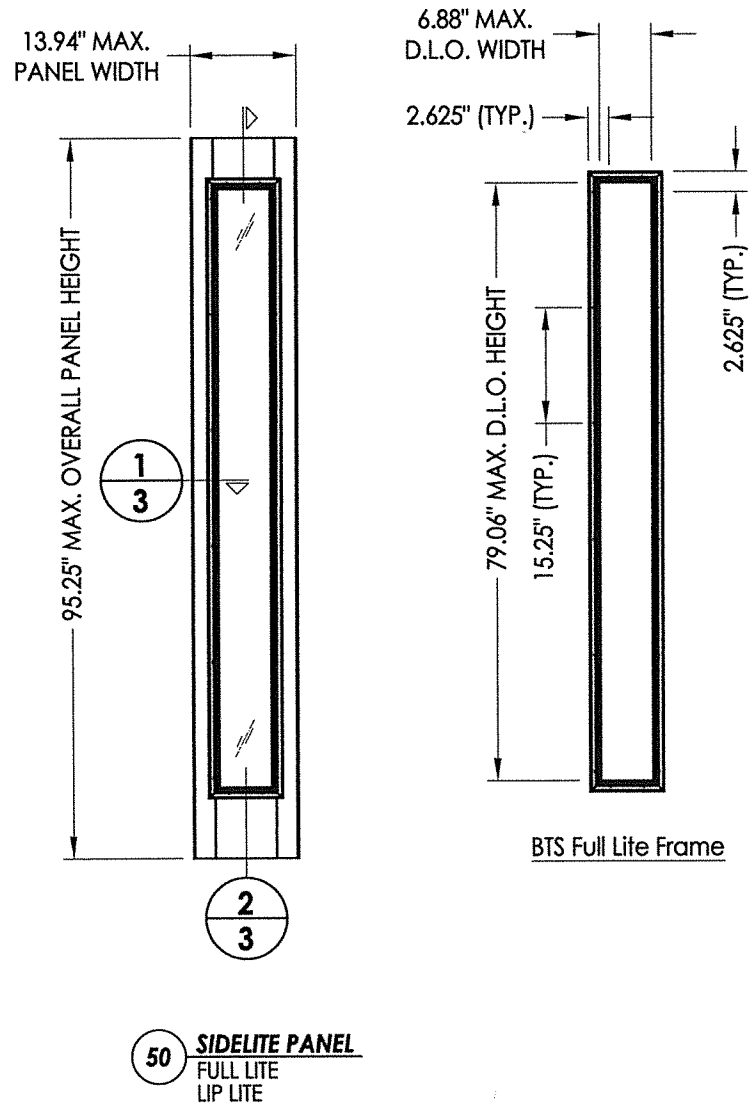

Documents Prepared By: Lyndon F. Schmidt, P.E.
TEXAS P.E. #104123

RW BUILDING CONSULTANTS, INC.
P.O. Box 230 Valrico FL 33595
Phone No.: 813.659.9197

CERTIFICATE OF REGISTRATION # F-11852

PRODUCT: THERMA TRU
FIBERGLASS DOOR

PART OR ASSEMBLY:
SIDELITE PANEL DETAILS

NO.	DATE	DESCRIPTION	BY
1	9/23/21	UPDATE TO 2018 IBC/IRC CODE	LFS

DATE: 11/14/17
SCALE: N.T.S.
DWG. BY: JK
CHK. BY: LFS
DRAWING NO.: TX-4743
SHEET 3 OF 11

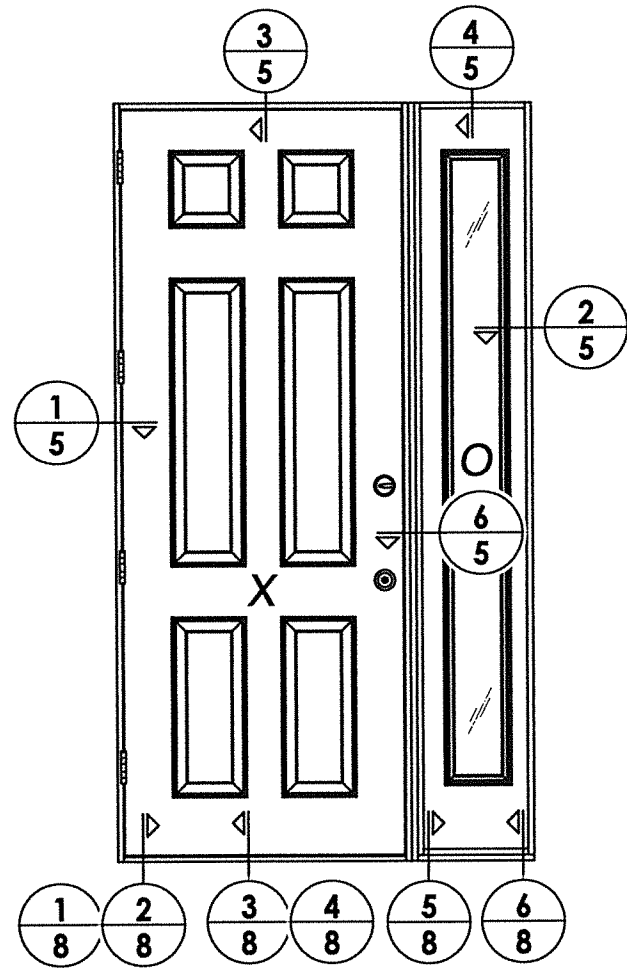

ELEVATION
XO

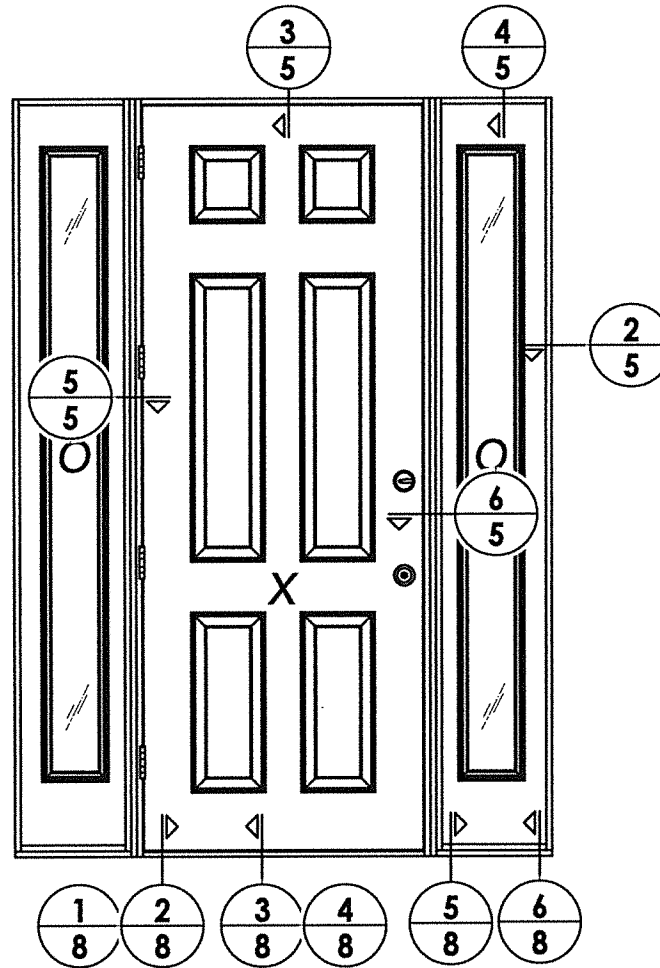

ELEVATION
OXO

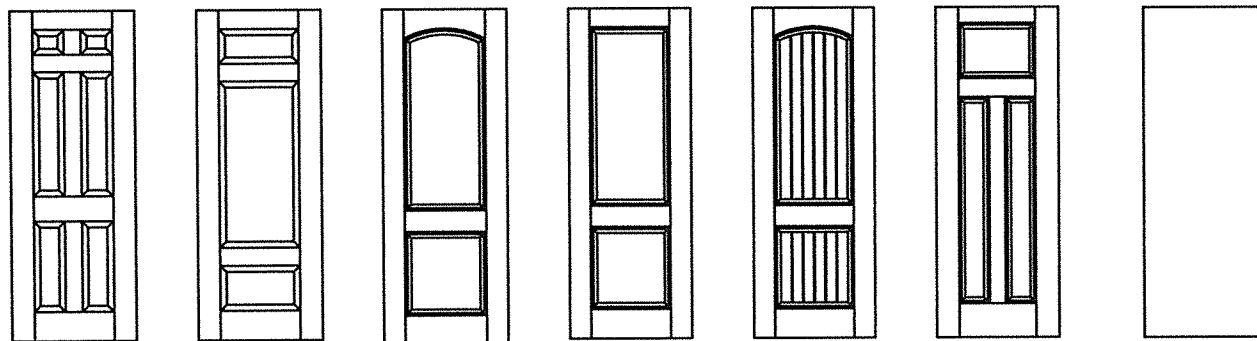

Fiber-Classic/Smooth-Star Door Panel Options
Panel options shown are for illustration and are representative only
(similar opaque panel configurations are allowed)

HARDWARE TABLE	
MANUFACTURER	MODEL
SCHLAGE	KNOB: F51 DEADBOLT: B60
KWIKSET	KNOB: SIGNATURE SERIES DEADBOLT: SIGNATURE SERIES (980)
HOPPE (THERMA-TRU)	MULTIPOINT : MPDGART (3 pt. Manual Tongue)

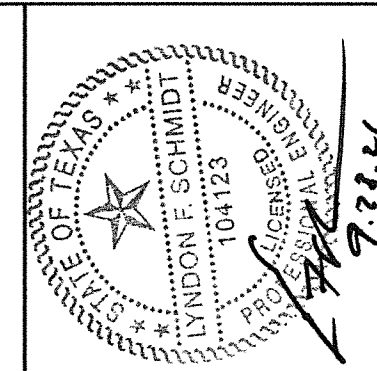

Documents Prepared By: Lyndon F. Schmidt, P.E.
TEXAS P.E. #104123

RW BUILDING CONSULTANTS, INC.
P.O. Box 230 Valrico FL, 33595
Phone No.: 813.659.9197

CERTIFICATE OF REGISTRATION # F-11852

PRODUCT: THERMA-TRU FIBERGLASS DOOR

PART OR ASSEMBLY: ELEVATIONS

NO.	DATE	REVISIONS
1	9/23/21	UPDATE TO 2018 IBC/IRC CODE
		LFS
		BY

DATE: 11/14/17
SCALE: N.T.S.
DWG. BY: JK
CHK. BY: LFS
DRAWING NO.: TX-4743
SHEET 4 OF 11

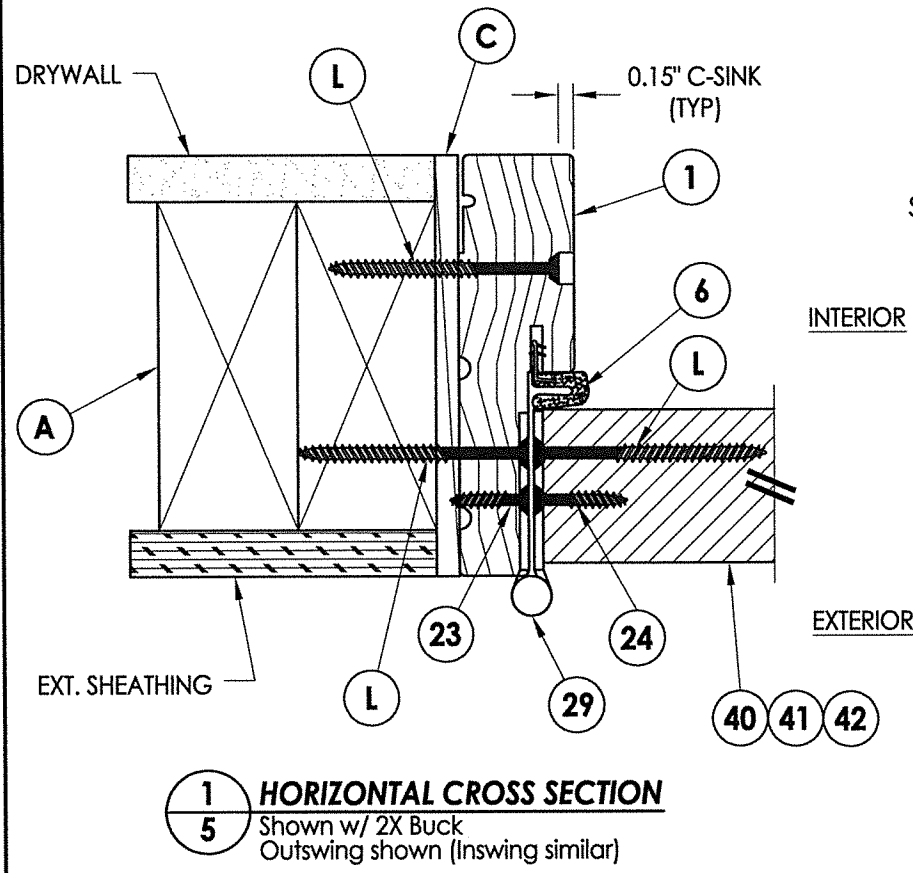

1 HORIZONTAL CROSS SECTION
5 Shown w/ 2X Buck
 Outswing shown (Inswing similar)

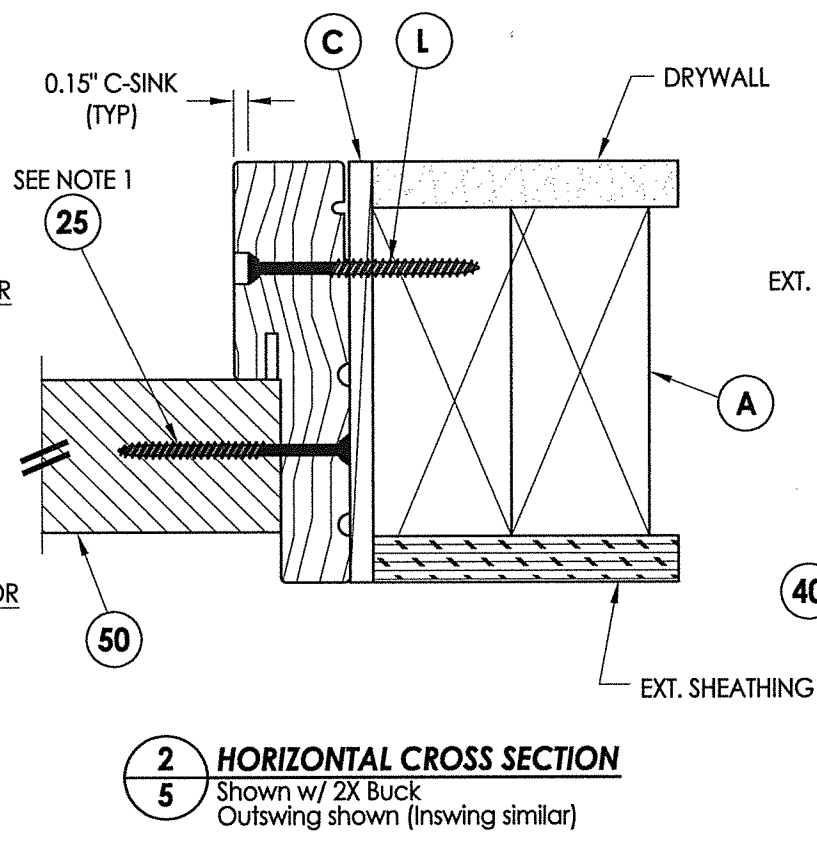

2 HORIZONTAL CROSS SECTION
5 Shown w/ 2X Buck
 Outswing shown (Inswing similar)

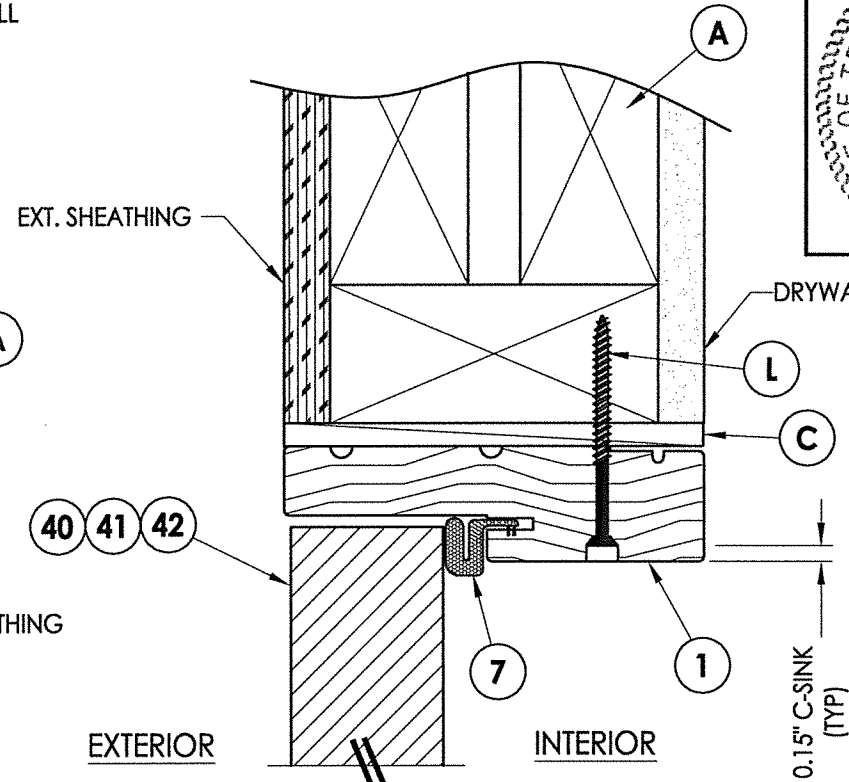

3 VERTICAL CROSS SECTION
5 Shown w/ 2X Buck
 Outswing shown (Inswing similar)

Notes:
 1. Sidelite assembly screws located 6" from each end and 6 more screws equally spaced between (8 screws total per side jamb).
 2. Sidelite assembly screws located 4" from each end (2 screws along head jamb).

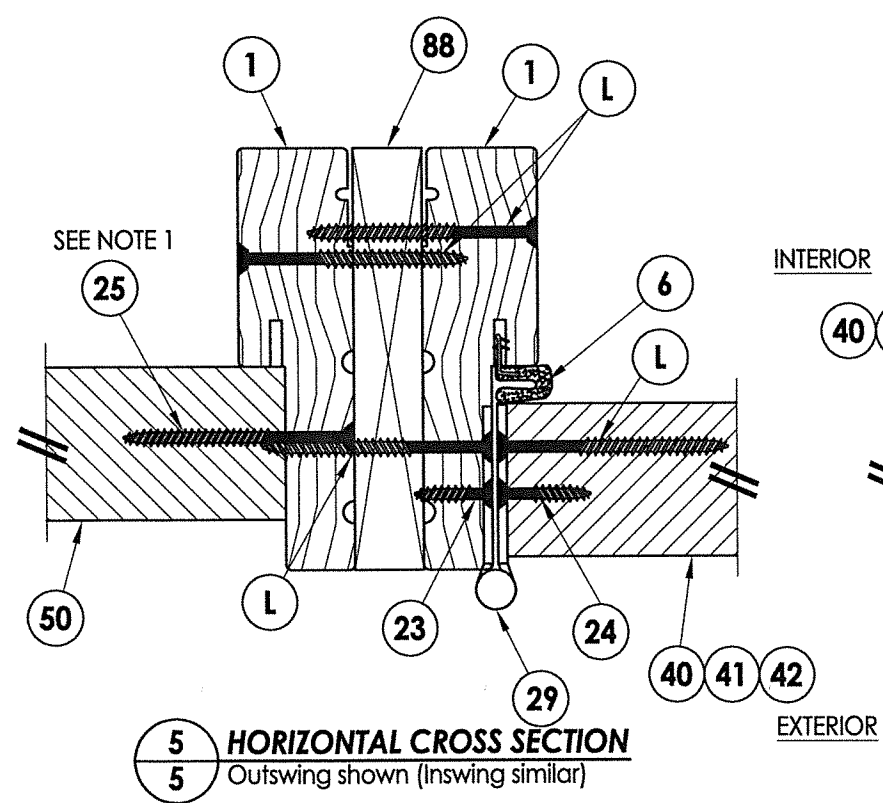

5 HORIZONTAL CROSS SECTION
5 Outswing shown (Inswing similar)

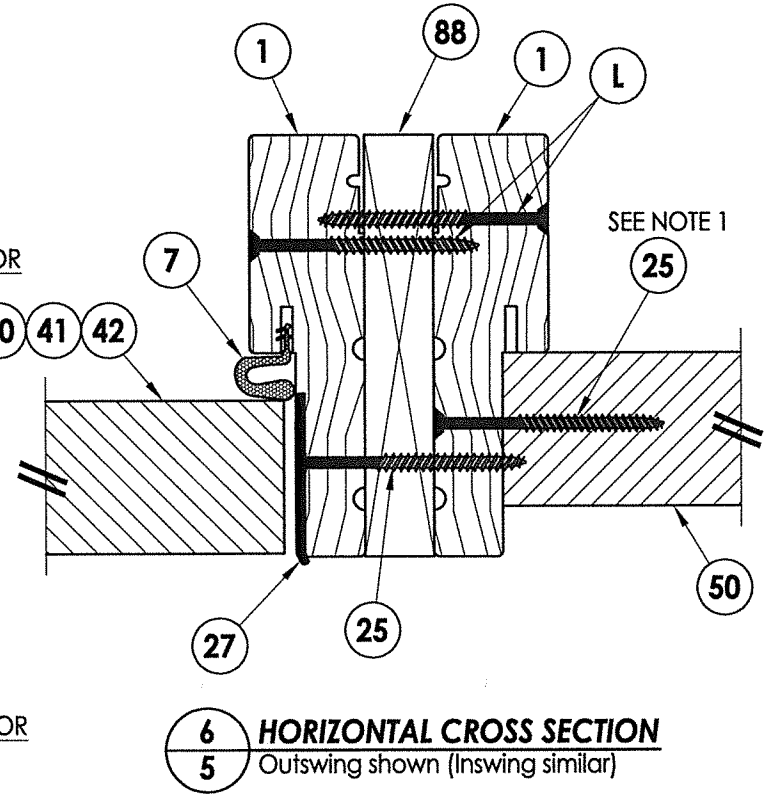

6 HORIZONTAL CROSS SECTION
5 Outswing shown (Inswing similar)

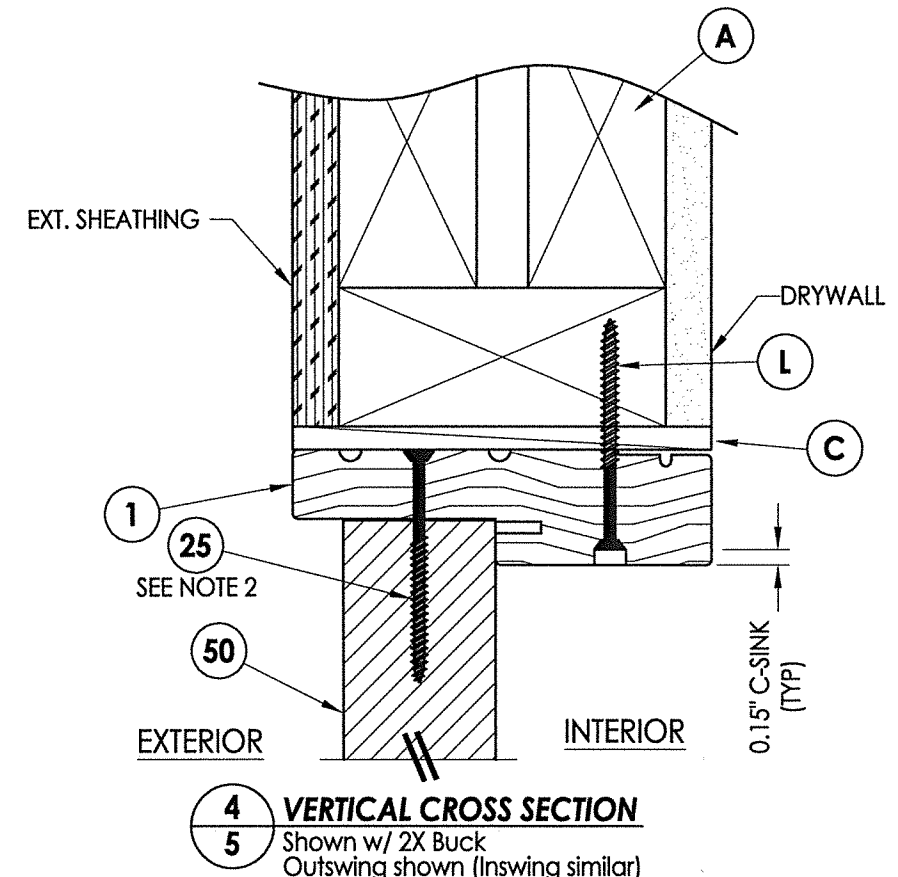

4 VERTICAL CROSS SECTION
5 Shown w/ 2X Buck
 Outswing shown (Inswing similar)

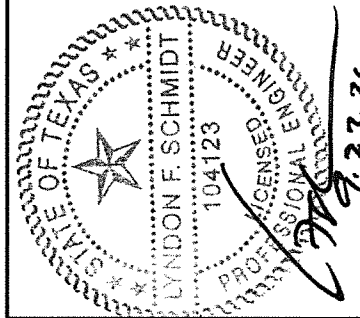

Documents Prepared By: Lyndon F. Schmidt, P.E.
 TEXAS P.E. #104123
RW BUILDING CONSULTANTS, INC.
 P.O. Box 230 Valrico FL 33595
 Phone No.: 813.659.9197
 CERTIFICATE OF REGISTRATION # F-11852

PRODUCT: THERMA-TRU FIBERGLASS DOOR
 PART OR ASSEMBLY: HORIZONTAL & VERTICAL CROSS SECTIONS

NO.	DATE	REVISIONS	LFS	BY
1	9/23/21	UPDATE TO 2018 IBC/IRC CODE	LFS	BY

DATE: 11/14/17
 SCALE: N.T.S.
 DWG. BY: JK
 CHK. BY: LFS
 DRAWING NO.: TX-4743
 SHEET 5 OF 11

Z:\Clients\Therma Tru PERMANENT\B - Texas Dept of Ins\TDI - DR 949 - 6'8 & 8'0 Opaque Comp Edge Coastal Impact w NI Sidelites (TX-4741 - 4744)\C - Drawings\TX-4743-44.dwg

Notes:

- Sill Item #'s 16, 32, 33, 34, 35, 36, 37, 38 & 39 are attached to jambs w/ (3) #8 X 2-1/2" pfh screws at each end.
Sill Item #'s 17, 18 & 19 are attached to jambs w/ (2) #8 X 2-1/2" pfh screws at each end.
Sill Item #15 is attached to jambs utilizing (2) #10 X 1-1/2" pph screws at each end.
- Sidelite assembly screws located 4" from each end (2 screws along sill).

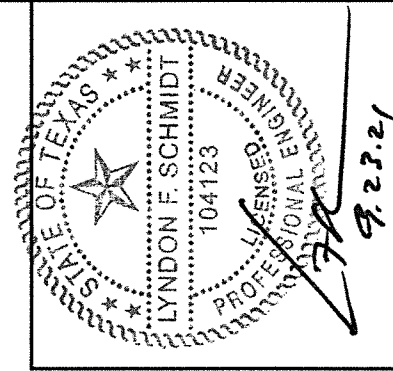

Documents Prepared By: Lyndon F. Schmidt, P.E.
TEXAS P.E. #104123

RW BUILDING CONSULTANTS, INC.
P.O. Box 230 Vairico FL 33595
Phone No.: 813.659.9197

CERTIFICATE OF REGISTRATION # F-11852

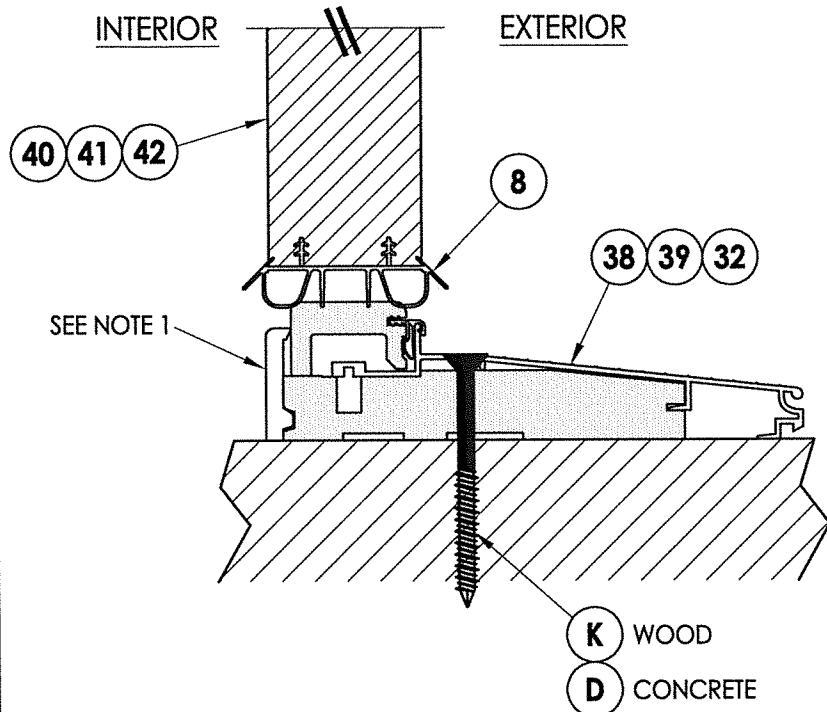

1 VERTICAL CROSS SECTION
6 Inswing Sill

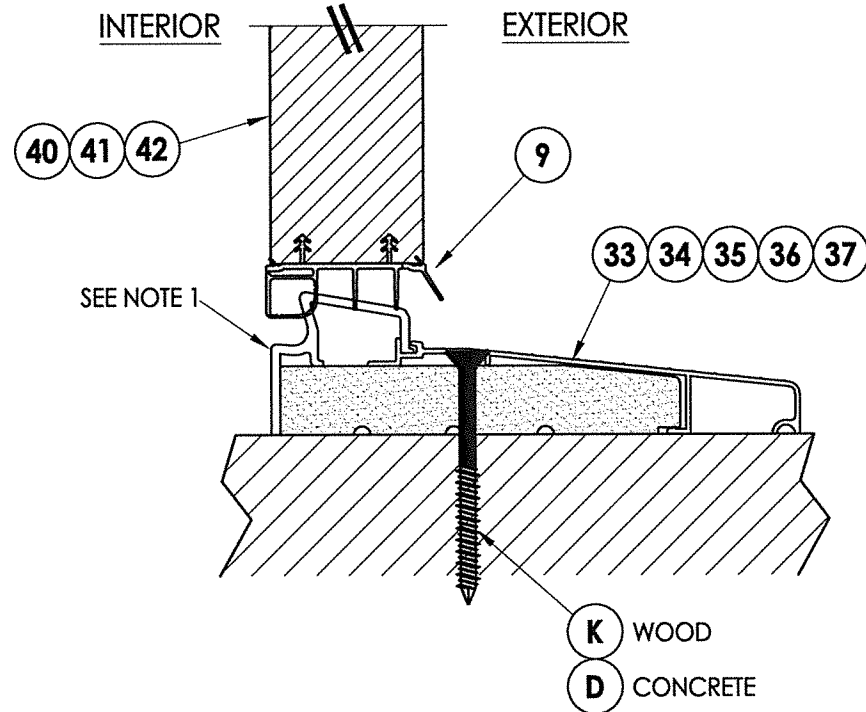

2 VERTICAL CROSS SECTION
6 Inswing Sill

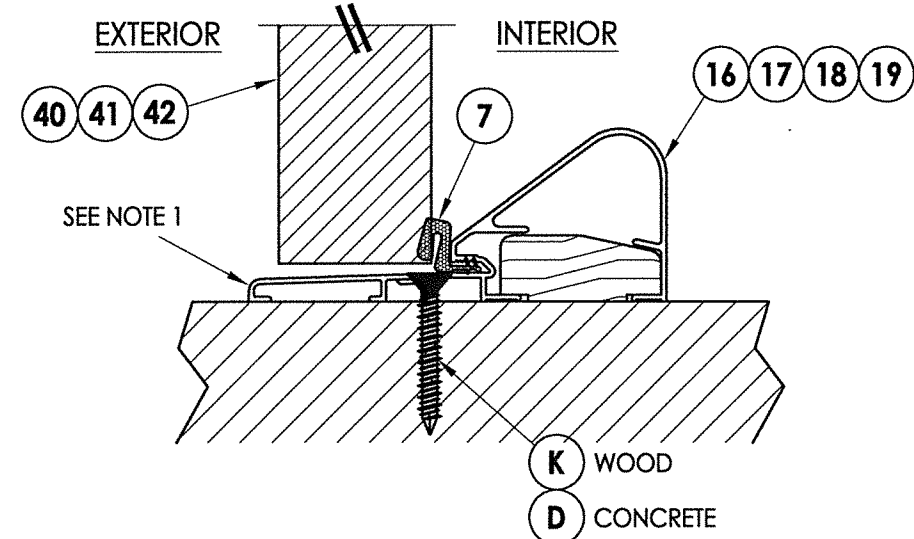

3 VERTICAL CROSS SECTION
6 Outswing Sill

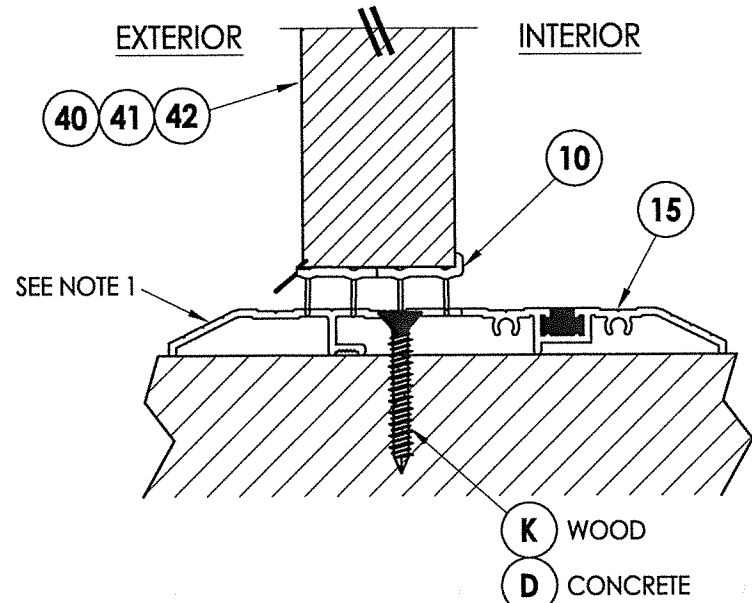

4 VERTICAL CROSS SECTION
6 Public Access Sill

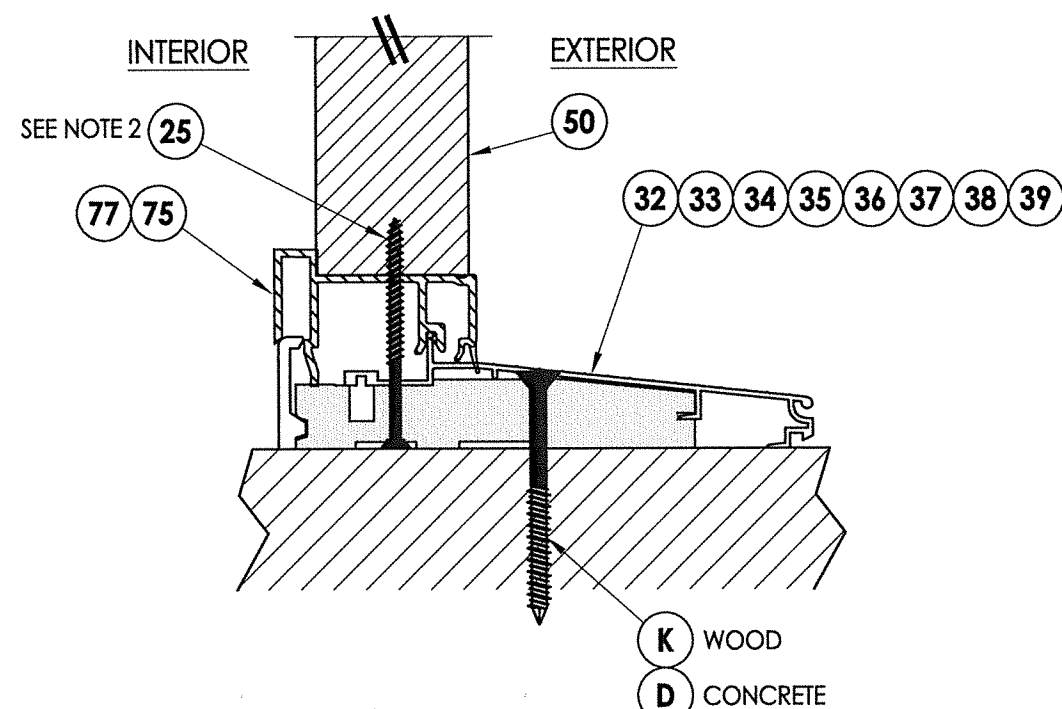

5 VERTICAL CROSS SECTION
6 Inswing Sill

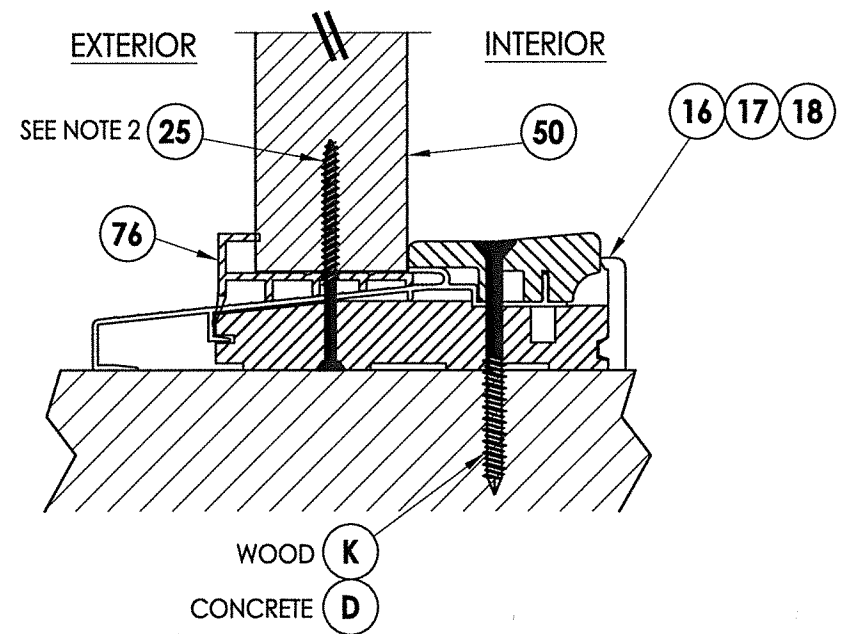

6 VERTICAL CROSS SECTION
6 Outswing Sill

PRODUCT: THERMA-TRU FIBERGLASS DOOR	
PART OR ASSEMBLY: VERTICAL CROSS SECTIONS (THRESHOLDS)	
NO.	DATE
1	9/23/21
UPDATE TO 2018 IBC/IRC CODE	
LFS	BY
REVISIONS	
DATE: 11/14/17	
SCALE: N.T.S.	
DWG. BY: JK	
CHK. BY: LFS	
DRAWING NO.: TX-4743	
SHEET 6 OF 11	

© 2017 R.W. BUILDING CONSULTANTS INC.

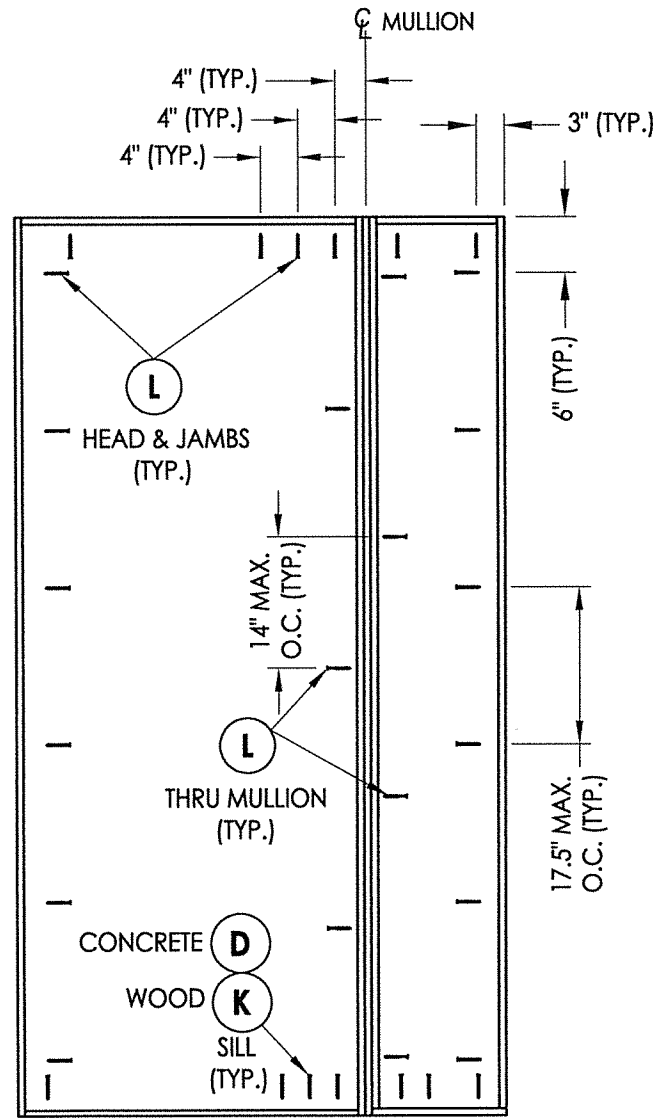
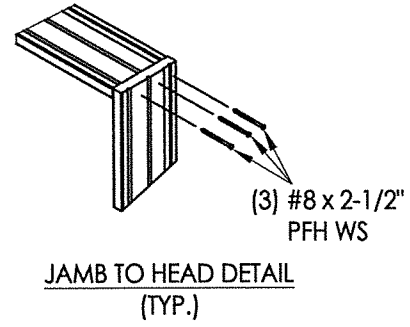

FRAME ANCHORING

FRAME ANCHORING

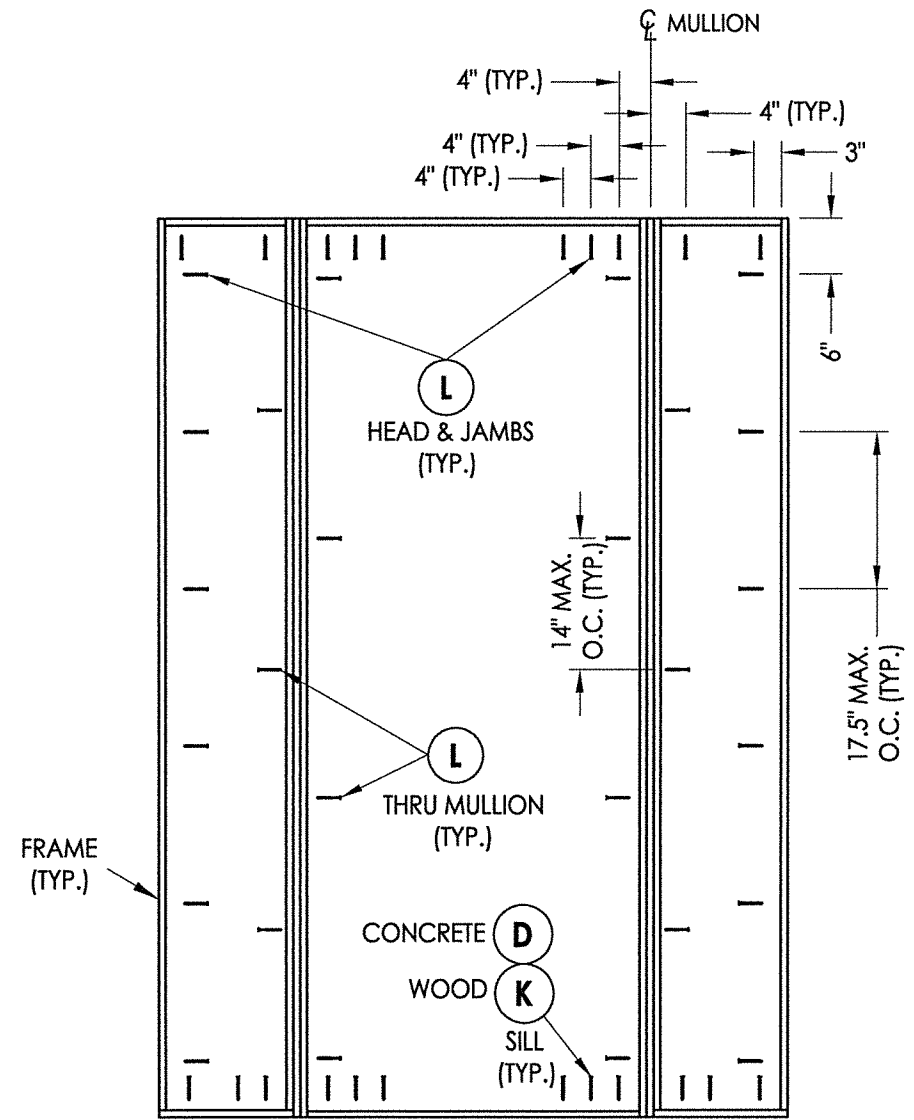

FRAME ANCHORING

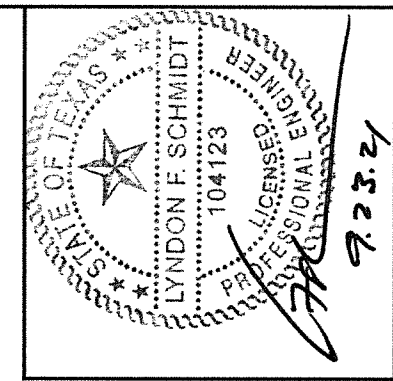

Documents Prepared By: Lyndon F. Schmidt, P.E.
TEXAS P.E. #104123

RW BUILDING CONSULTANTS, INC.
P.O. Box 230 Valrico FL, 33595
Phone No.: 813.659.9197

CERTIFICATE OF REGISTRATION # F-11852

PRODUCT: THERMA-TRU FIBERGLASS DOOR

PART OR ASSEMBLY: FRAME ANCHORING

NO.	DATE	DESCRIPTION	LFS	BY
1	9/23/21	UPDATE TO 2018 IBC/IRC CODE	LFS	JK

DATE: 11/14/17

SCALE: N.T.S.

DWG. BY: JK

CHK. BY: LFS

DRAWING NO.: TX-4743

SHEET 7 OF 11

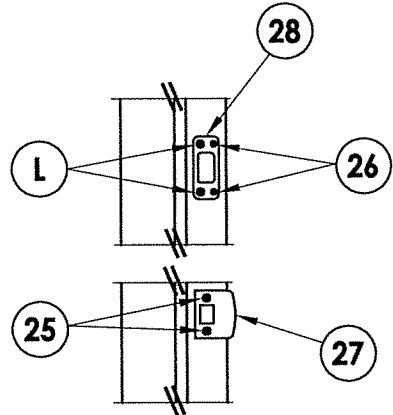

LATCH & DEADBOLT DETAIL
Kwikset

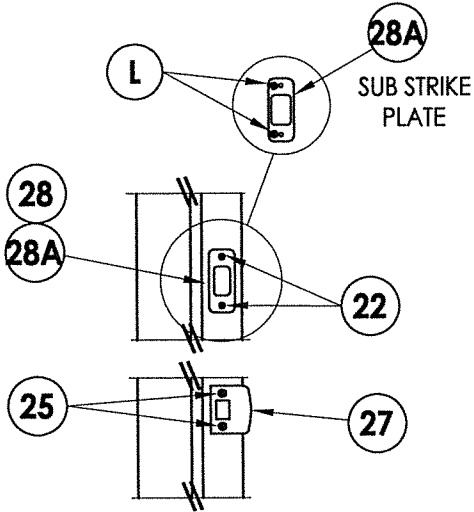

LATCH & DEADBOLT DETAIL
Schlage

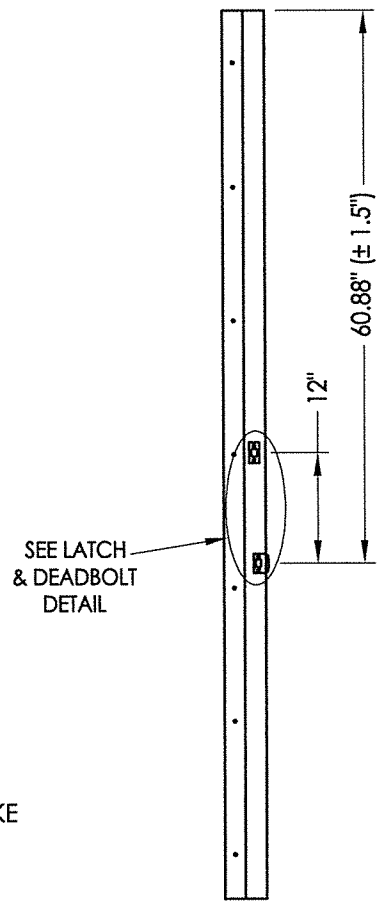

STRIKE JAMB
Latch and Deadbolt

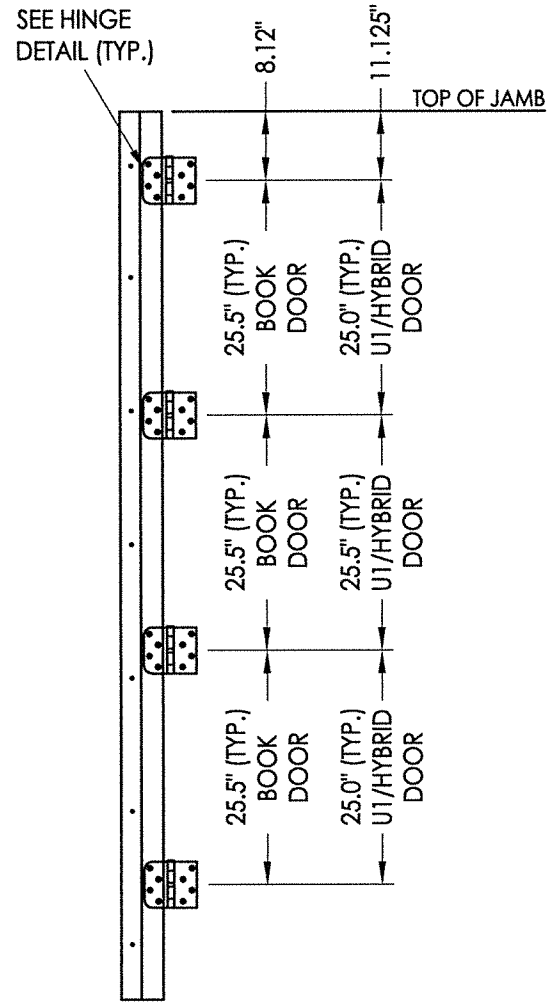

HINGE JAMB

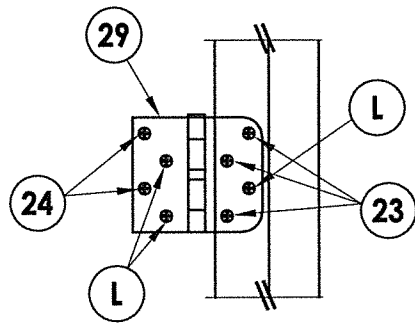

HINGE DETAIL

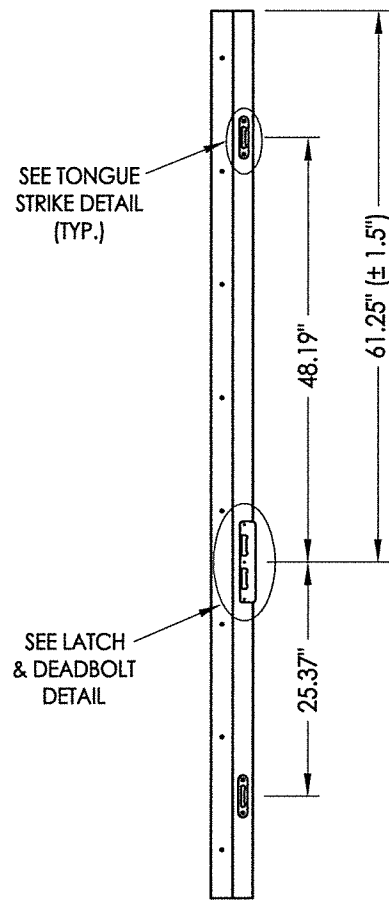

STRIKE JAMB
Multipoint Lock

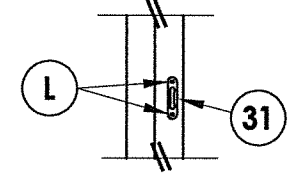

TONGUE STRIKE DETAIL
Multipoint Lock

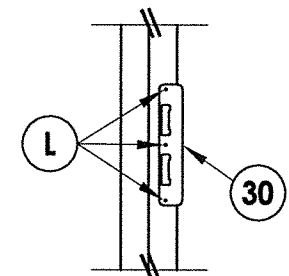

LATCH & DEADBOLT DETAIL
Multipoint Lock

LATCH & DEADBOLT STRIKE DETAILS

MULTIPOINT LOCK STRIKE DETAILS

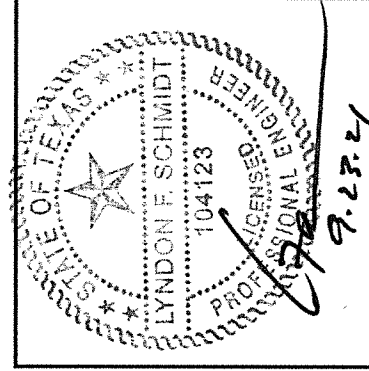

Documents Prepared By: Lyndon F. Schmidt, P.E.
TEXAS P.E. #104123

R.W. BUILDING CONSULTANTS, INC.
P.O. Box 230 Vairico FL 33595
Phone No.: 813.659.9197

CERTIFICATE OF REGISTRATION # F-11852

PRODUCT: THERMA-TRU FIBERGLASS DOOR
PART OR ASSEMBLY: HARDWARE DETAILS

NO.	DATE	REVISIONS
1	9/23/21	UPDATE TO 2018 IBC/IRC CODE
		LFS
		BY

DATE: 11/14/17
SCALE: N.T.S.
DWG. BY: JK
CHK. BY: LFS
DRAWING NO.: TX-4743
SHEET 8 OF 11

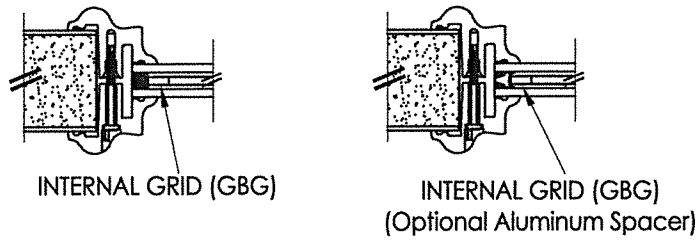
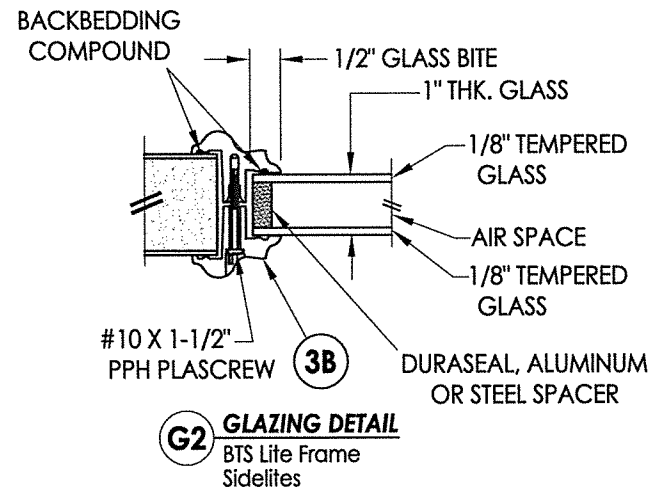
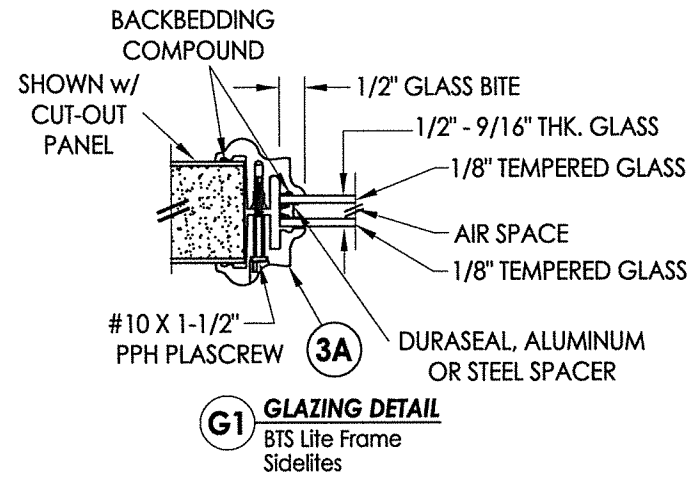

9/16" INSULATED GLASS INSERT OPTIONS

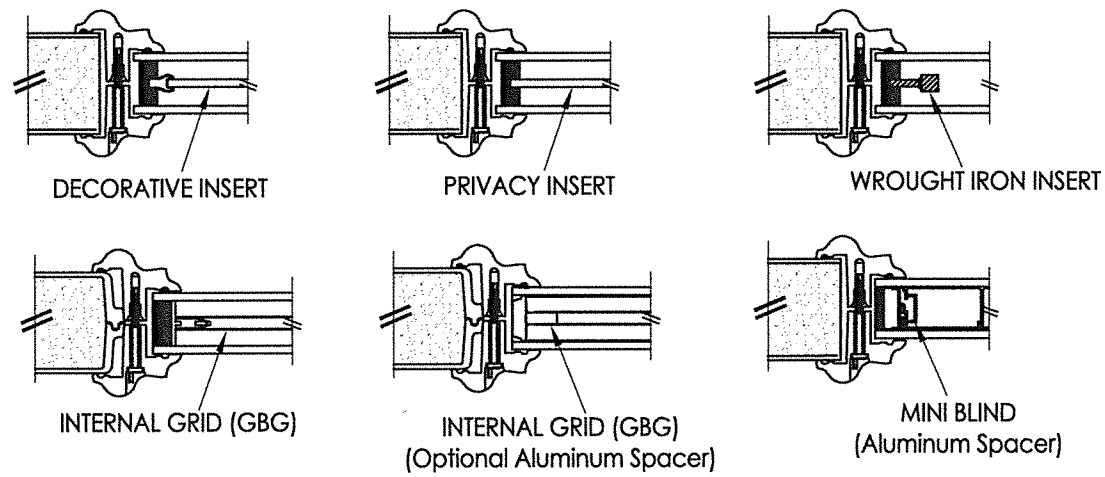

1" INSULATED GLASS INSERT OPTIONS

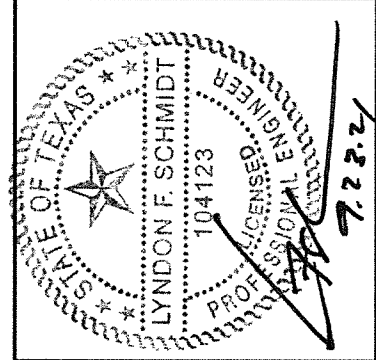
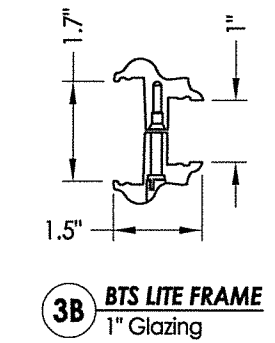
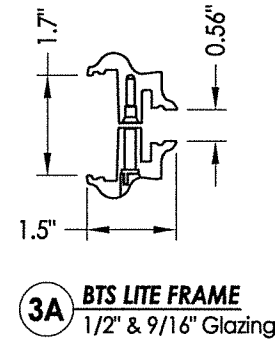

Documents Prepared By: Lyndon F. Schmidt, P.E.
TEXAS P.E. #104123

RW BUILDING CONSULTANTS, INC.
P.O. Box 230 Valrico FL 33595
Phone No.: 813.659.9197

CERTIFICATE OF REGISTRATION # F-11852

PRODUCT:		THERMA-TRU FIBERGLASS DOOR	
PART OR ASSEMBLY:		GLAZING DETAILS	
NO.	DATE	DESCRIPTION	BY
1	9/23/21	UPDATE TO 2018 IBC/IRC CODE	LFS
			REVISIONS
DATE: 11/14/17			
SCALE: N.T.S.			
DWG. BY: JK			
CHK. BY: LFS			
DRAWING NO.: TX-4743			
SHEET 9 OF 11			

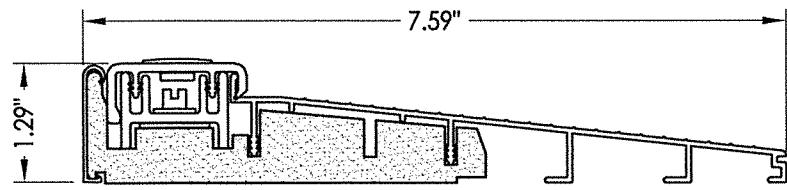

32 INSWING THRESHOLD
Inswing Basic Composite Adjustable Sill 7-1/2"

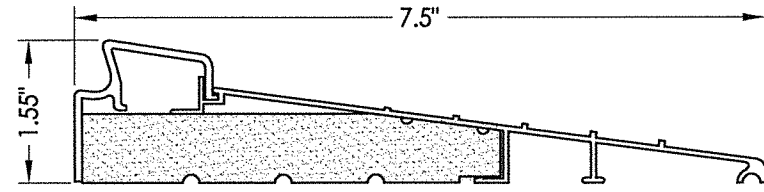

37 INSWING THRESHOLD
Inswing Basic Fixed 7-1/2" Sill

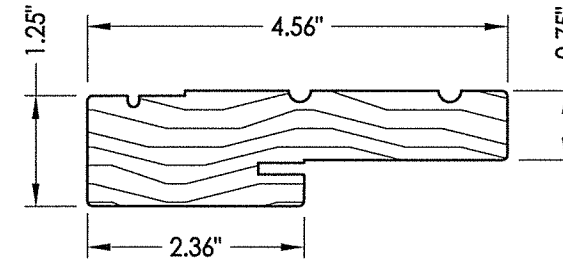

1 WOOD JAMB

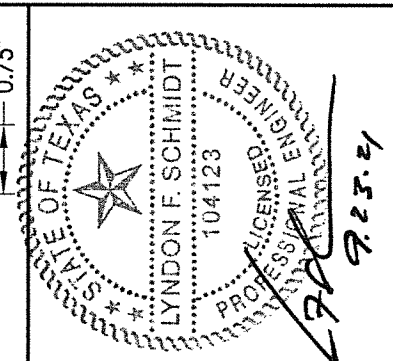

Documents Prepared By: Lyndon F. Schmidt, P.E.
TEXAS P.E. #104123

RW BUILDING CONSULTANTS, INC.
P.O. Box 230 Valrico FL 33595
Phone No.: 813.659.9197

CERTIFICATE OF REGISTRATION # F-11852

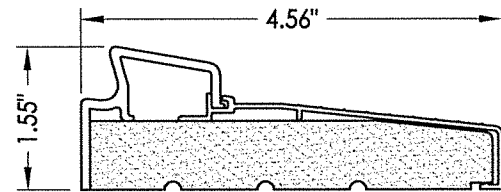

33 INSWING THRESHOLD
Inswing Basic Fixed Sill

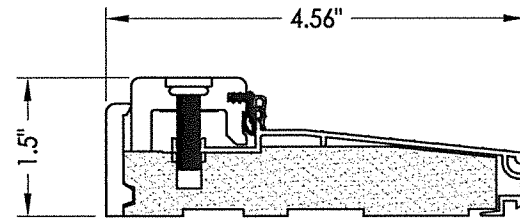

38 INSWING THRESHOLD
Inswing Composite Adjustable Sill

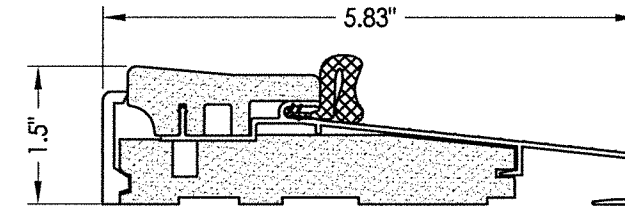

16 OUTSWING THRESHOLD
Composite Sill

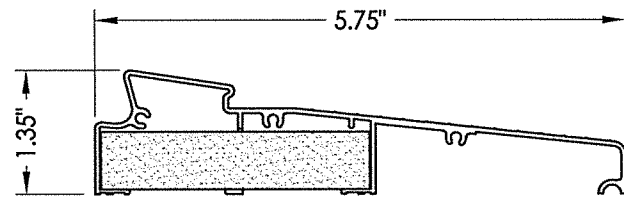

34 INSWING THRESHOLD
Inswing Moderate Climate Sill 1-3/8"

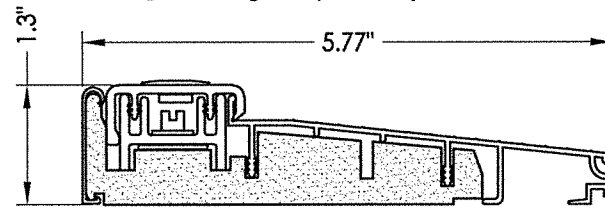

39 INSWING THRESHOLD
Inswing Basic Composite Adjustable Sill

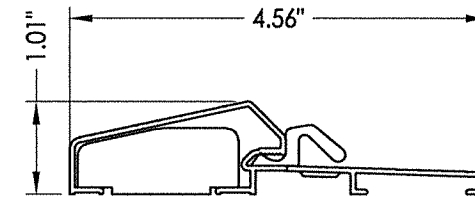

17 OUTSWING THRESHOLD
Composite / Aluminum Sill

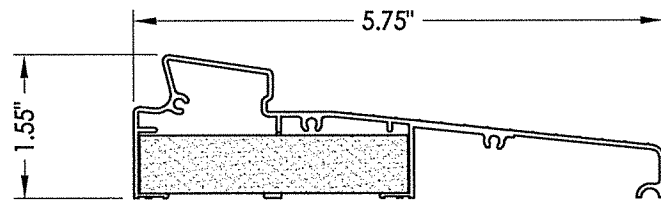

35 INSWING THRESHOLD
Inswing Moderate Climate Sill

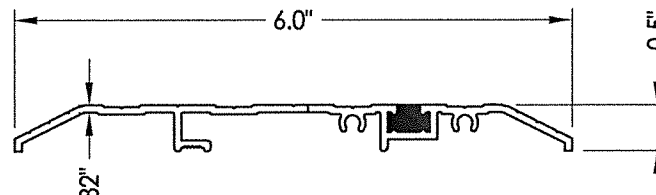

15 PUBLIC ACCESS THRESHOLD

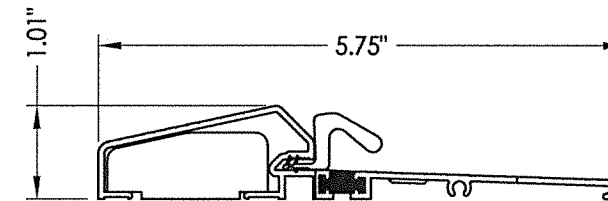

18 OUTSWING THRESHOLD
Composite / Aluminum Sill
(Thermal Break)

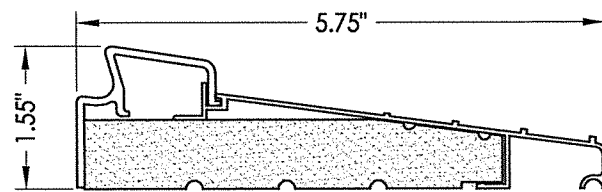

36 INSWING THRESHOLD
Inswing Basic Fixed 5-3/4" Sill

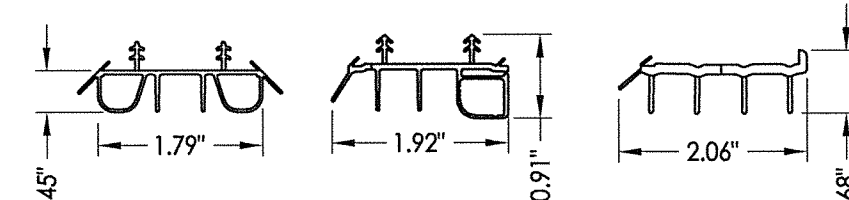

8 SWEEP

9 SWEEP

10 SWEEP

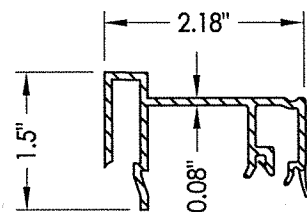

75 SIDELITE SPACER
Inswing

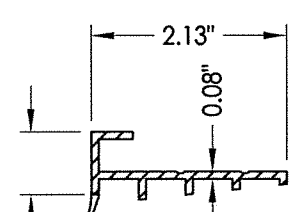

76 SIDELITE SPACER
Outswing

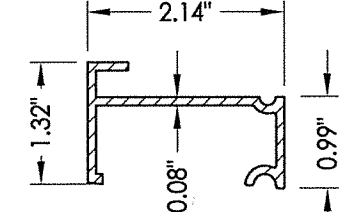

77 SIDELITE SPACER
Inswing
Moderate Climate Threshold

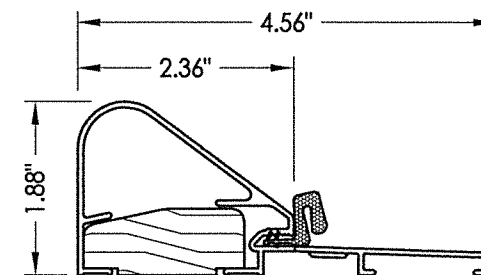

19 COASTAL OUTSWING THRESHOLD
Wood / Aluminum Sill

PRODUCT:		THERMA-TRU FIBERGLASS DOOR	
PART OR ASSEMBLY:		COMPONENTS	
NO.	DATE	UPDATE TO 2018 IBC/IRC CODE	BY
1	9/23/21	LFS	BY
REVISIONS			
DATE: 11/14/17			
SCALE: N.T.S.			
DWG. BY: JK			
CHK. BY: LFS			
DRAWING NO.: TX-4743			
SHEET 10 OF 11			

BILL OF MATERIALS		
ITEM #	DESCRIPTION	MATERIAL
A	2X FRAMING (SG >= 0.42)	WOOD
C	1/4" MAX. SHIM SPACE	-
D	1/4" PFH DeWALT OR ITW CONCRETE SCREW (1-3/4" MIN. EMBEDMENT)	STEEL
K	#12 PFH WOOD SCREW (1-1/2" MIN. EMBEDMENT)	STEEL
L	#10 X 2-1/2" PFH WOOD SCREW (1.15" MIN. EMBEDMENT)	STEEL
1	JAMB (FINGER JOINT PINE)	WOOD
6	WEATHERSTRIP (MEDIUM REACH)	FOAM
7	WEATHERSTRIP (LONG REACH)	FOAM
8	SWEEP	VINYL
9	SWEEP (USE w/ MODERATE CLIMATE THRESHOLD)	VINYL
10	SWEEP (USE w/ PUBLIC ACCESS THRESHOLD)	VINYL
15	PUBLIC ACCESS THRESHOLD	ALUM
16	OUTSWING THRESHOLD	ALUM/COMP
17	OUTSWING THRESHOLD	ALUM/COMP
18	OUTSWING THRESHOLD	ALUM/COMP
19	COASTAL OUTSWING THRESHOLD	ALUM/WOOD
22	#8 x 3/4" PFH WOOD SCREW	STEEL
23	#10 x 3/4" PFH WOOD SCREW	STEEL
24	#10 x 1" PFH WOOD SCREW	STEEL
25	#8 x 2-1/2" PFH WOOD SCREW	STEEL
26	#8 x 5/8" PFH WOOD SCREW	STEEL
27	LATCH STRIKE PLATE	STEEL
28	DEADBOLT SUB STRIKE PLATE	STEEL
28A	DEADBOLT SUB STRIKE PLATE	STEEL
29	4" X 4" HINGE	STEEL
30	LATCH & DEADBOLT STRIKE PLATE (TONGUE SYSTEM)	ALUM/COMP
31	MULTIPOINT STRIKE PLATE (TONGUE SYSTEM)	ALUM/COMP
32	INSWING THRESHOLD	ALUM/COMP
33	INSWING THRESHOLD	ALUM/COMP
34	INSWING THRESHOLD	ALUM/COMP
35	INSWING THRESHOLD	ALUM/COMP
36	INSWING THRESHOLD	ALUM/COMP
37	INSWING THRESHOLD	ALUM/COMP
38	INSWING THRESHOLD	ALUM/COMP
39	INSWING THRESHOLD	ALUM/COMP
40	DOOR PANEL (BOOK)	-
41	DOOR PANEL (HYBRID)	-
42	DOOR PANEL (U1)	-
50	SIDELITE	-
75	SIDELITE SPACER (INSWING)	PVC
76	SIDELITE SPACER (OUTSWING)	PVC
77	SIDELITE SPACER (INSWING) - MODERATE CLIMATE SILL	PVC
88	2X MULLION (SG >= 0.55)	WOOD

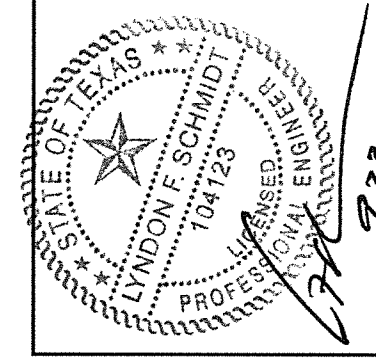

Documents Prepared By: Lyndon F. Schmidt, P.E.
TEXAS P.E. #104123

RW BUILDING CONSULTANTS, INC.
P.O. Box 250 Vairico FL 33595
Phone No.: 813.659.9197

CERTIFICATE OF REGISTRATION # F-11852

PRODUCT: THERMA-TRU
FIBERGLASS DOOR

PART OR ASSEMBLY:
BILL OF MATERIALS

NO.	DATE	DESCRIPTION	LFS	BY
1	9/23/21	UPDATE TO 2018 IBC/IRC CODE		

REVISIONS

DATE: 11/14/17
SCALE: N.T.S.
DWG. BY: JK
CHK. BY: LFS
DRAWING NO.: TX-4743
SHEET 11 OF 11

CONCRETE ANCHOR NOTES:

- Concrete anchor locations at the corners may be adjusted to maintain the min. edge distance to mortar joints.
- Concrete anchor locations noted as "MAX. ON CENTER" must be adjusted to maintain the min. edge distance to mortar joints, additional concrete anchors may be required to ensure the "MAX. ON CENTER" dimension are not exceeded.
- Concrete anchor table:

ANCHOR TYPE	ANCHOR SIZE	MIN. EMBEDMENT	MIN. CLEARANCE TO MASONRY EDGE	MIN. CLEARANCE TO ADJACENT ANCHOR
ITW TAPCON®	1/4"	1-3/4"	2"	4"
DeWALT ULTRACON+®	1/4"	1-3/4"	1"	4"

WOOD SCREW INSTALLATION NOTES:

- Maintain a minimum 5/8" edge distance, 1" end distance, & 1" o.c. spacing of wood screws to prevent the splitting of wood.