

Z:\Clients\Therma Tru PERMANENT\B - Texas Dept of Ins\TDI - DR 948 - 6'8 & 8'0 Glazed FG NonImp IS Vented Sidelites (TX 4753-4754)\C - Drawings\TX-4754.dwg

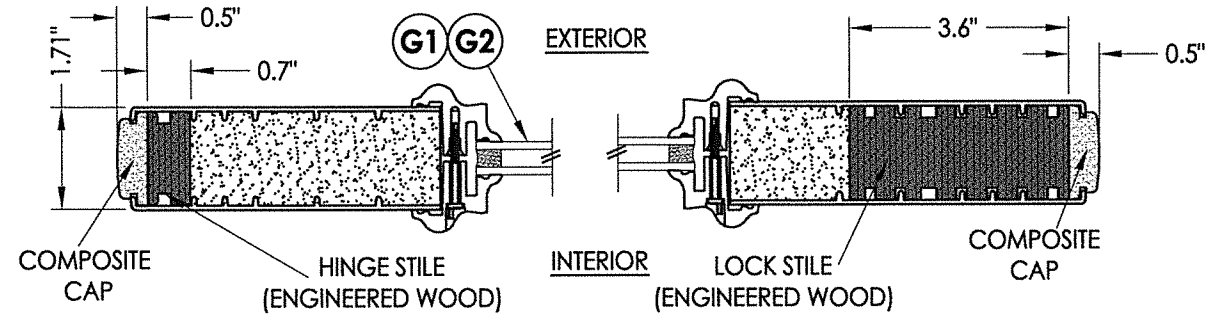

1 HORIZONTAL CROSS SECTION

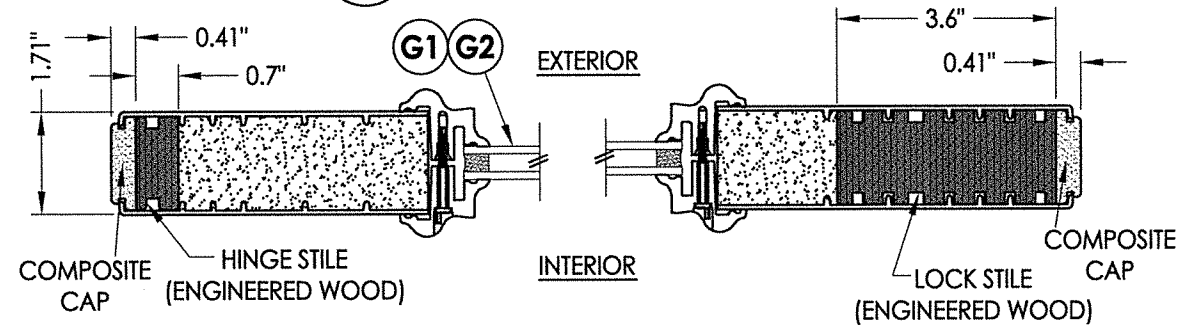

2 HORIZONTAL CROSS SECTION

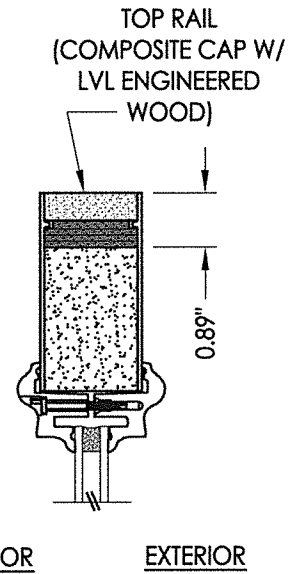
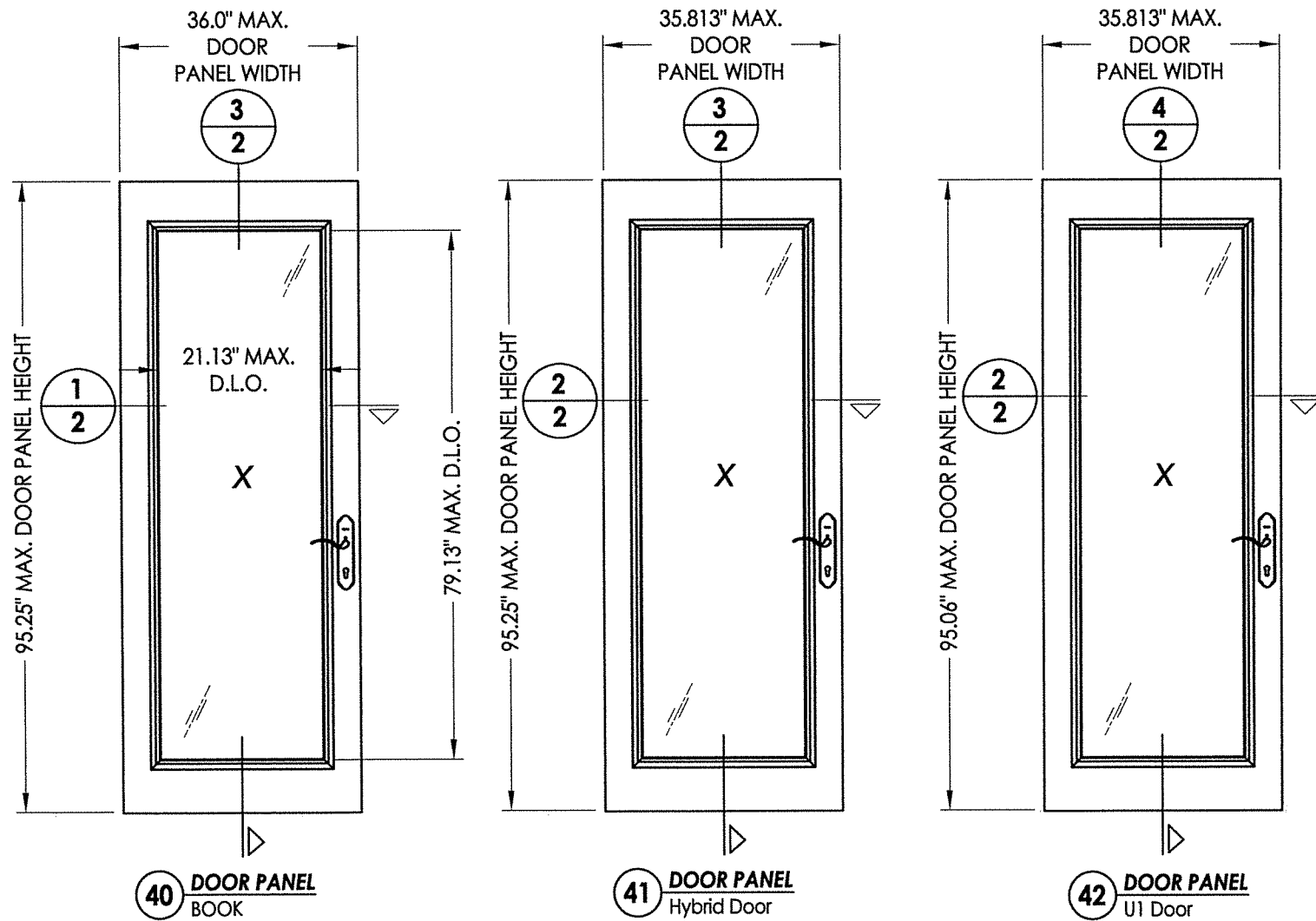

3 VERTICAL CROSS SECTION

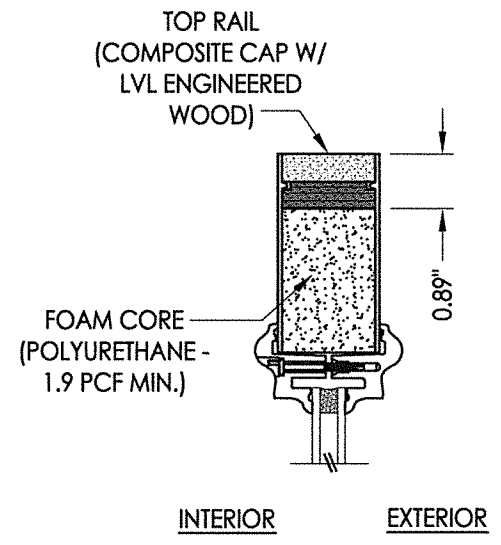

4 VERTICAL CROSS SECTION

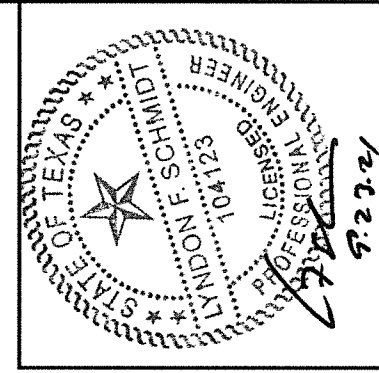

Documents Prepared By: Lyndon F. Schmidt, P.E.
TEXAS P.E. #104123

RW BUILDING CONSULTANTS, INC.
P.O. Box 230 Valrico FL 33595
Phone No.: 813.659.9197
TEXAS BOARD OF PROFESSIONAL ENGINEERS
CERTIFICATE OF REGISTRATION # F-11852

PRODUCT:	THERMA-TRU FIBERGLASS DOOR	
PART OR ASSEMBLY:	DOOR PANEL DETAILS	
NO.	DATE	REVISIONS
1	9/23/21	UPDATE TO 2018 IBC/IRC CODE
LFS	BY	
DATE: 11/29/17		
SCALE: N.T.S.		
DWG. BY: JK		
CHK. BY: LFS		
DRAWING NO.: TX-4754		
SHEET 2 OF 14		

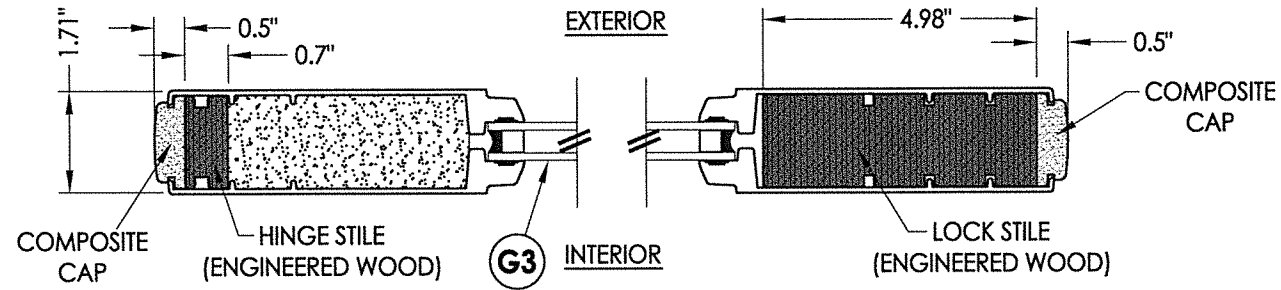

1
3 HORIZONTAL CROSS SECTION

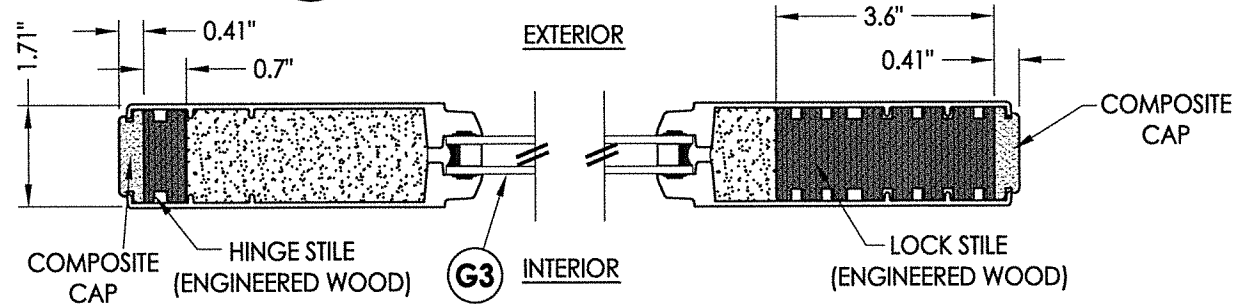

2
3 HORIZONTAL CROSS SECTION

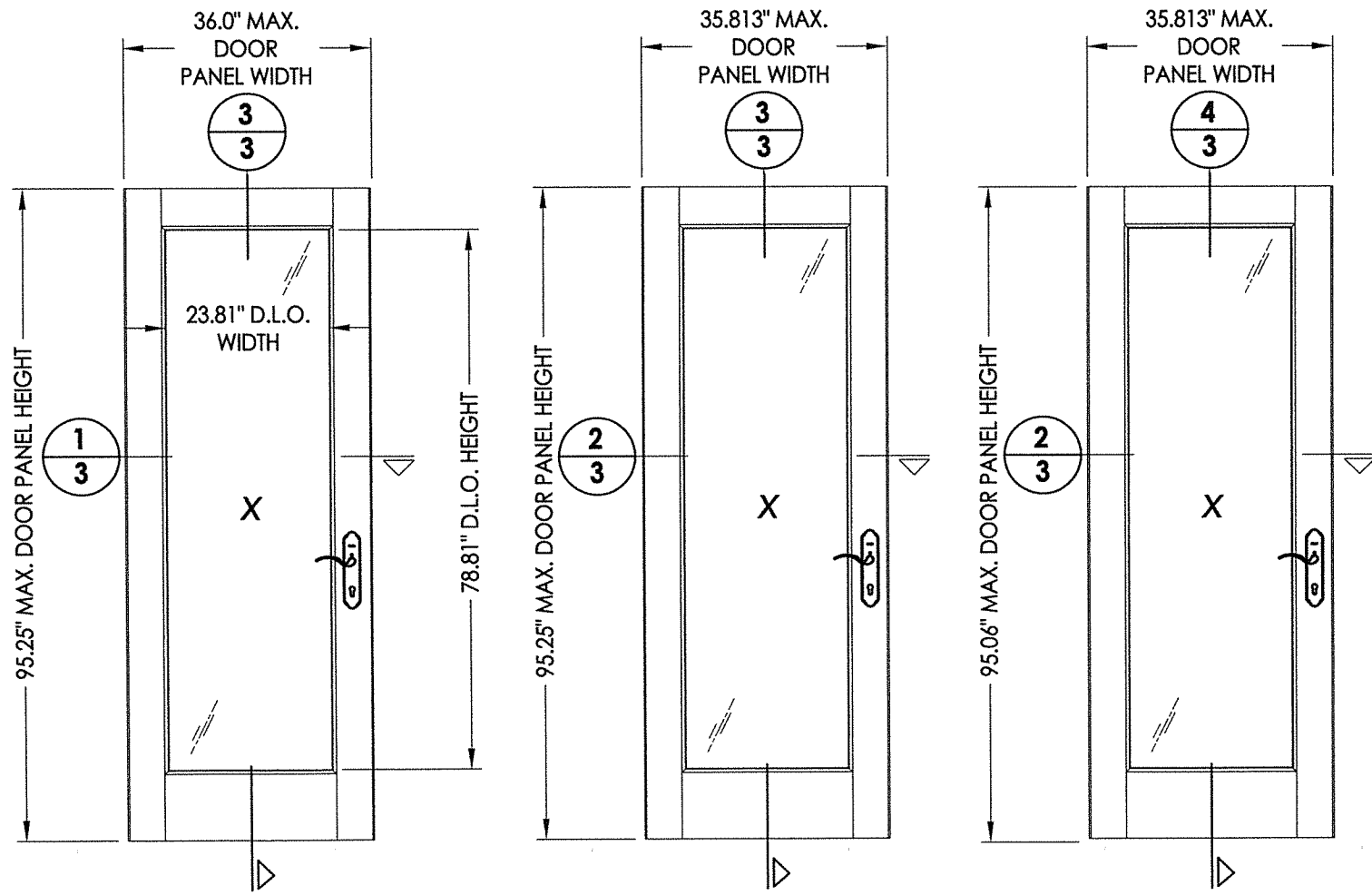

43 DOOR PANEL BOOK

44 DOOR PANEL Hybrid Door

45 DOOR PANEL U1 Door

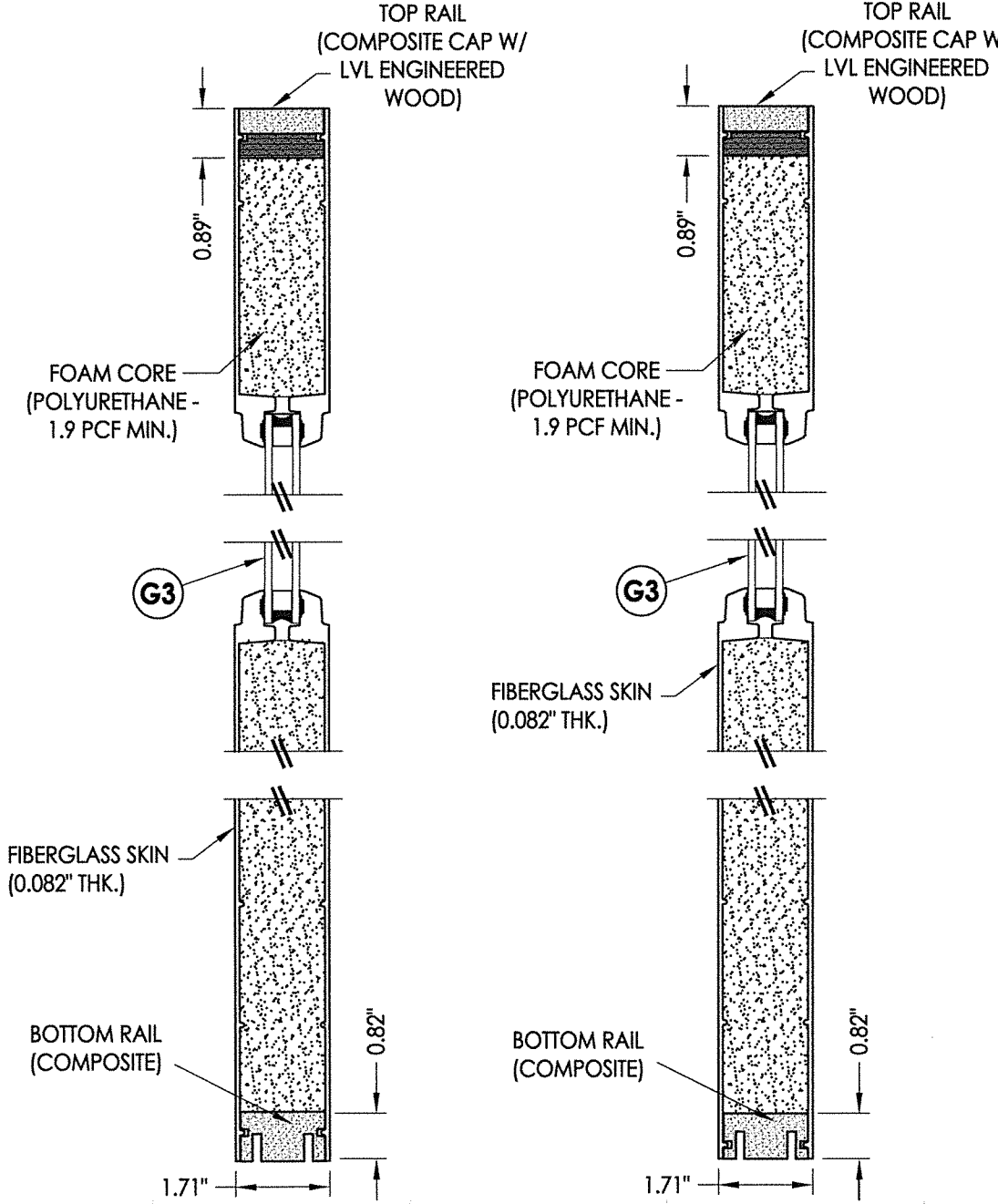

3
3 VERTICAL CROSS SECTION

4
3 VERTICAL CROSS SECTION

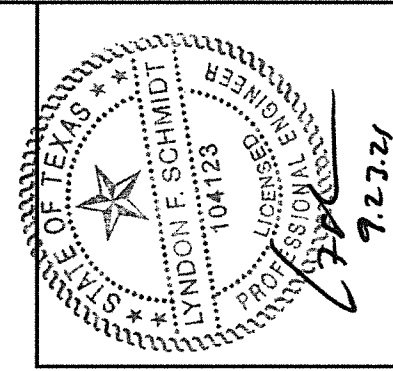

Documents Prepared By: Lyndon F. Schmidt, P.E.
TEXAS P.E. #104123
RW BUILDING CONSULTANTS, INC.
P.O. Box 230 Valrico FL 33595
Phone No.: 813.659.9197
TEXAS BOARD OF PROFESSIONAL ENGINEERS
CERTIFICATE OF REGISTRATION # F-11852

PRODUCT:	THERMA-TRU FIBERGLASS DOOR			
PART OR ASSEMBLY:	DOOR PANEL DETAILS			
DATE:	11/29/17			
SCALE:	N.T.S.			
DWG. BY:	JK			
CHK. BY:	LFS			
DRAWING NO.:	TX-4754			
SHEET	3 OF 14			
NO.	1	DATE	9/23/21	UPDATE TO 2018 IBC/IRC CODE
BY	LFS	REVISIONS		

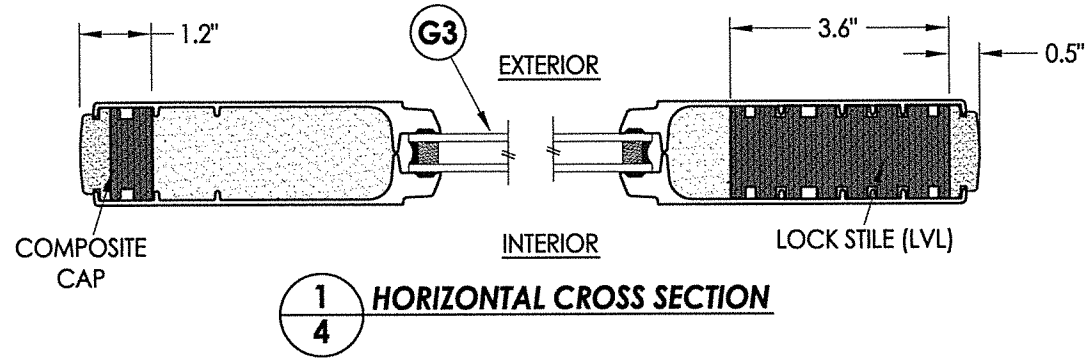

1
4 HORIZONTAL CROSS SECTION

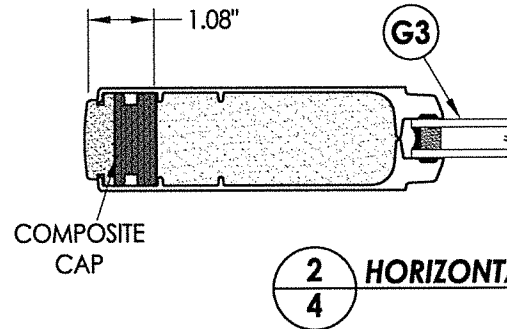

2
4 HORIZONTAL CROSS SECTION

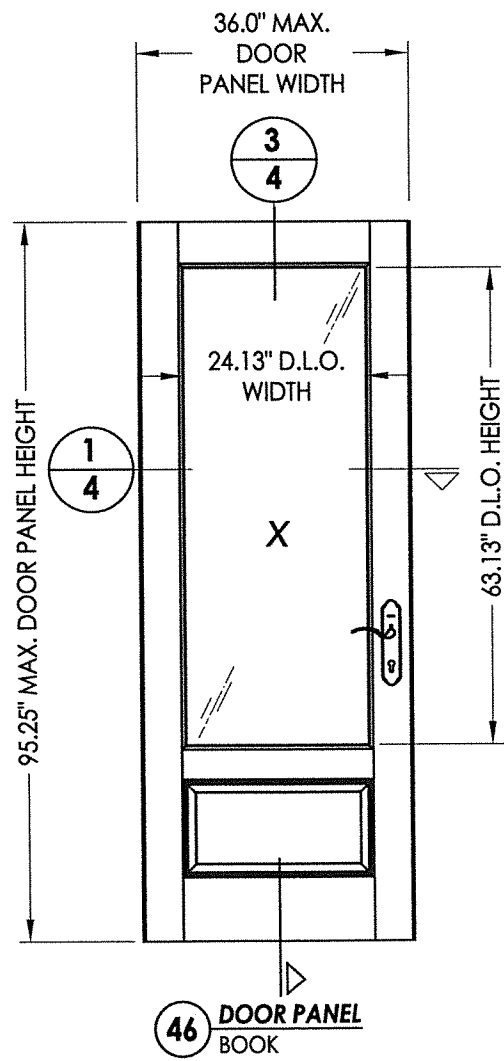
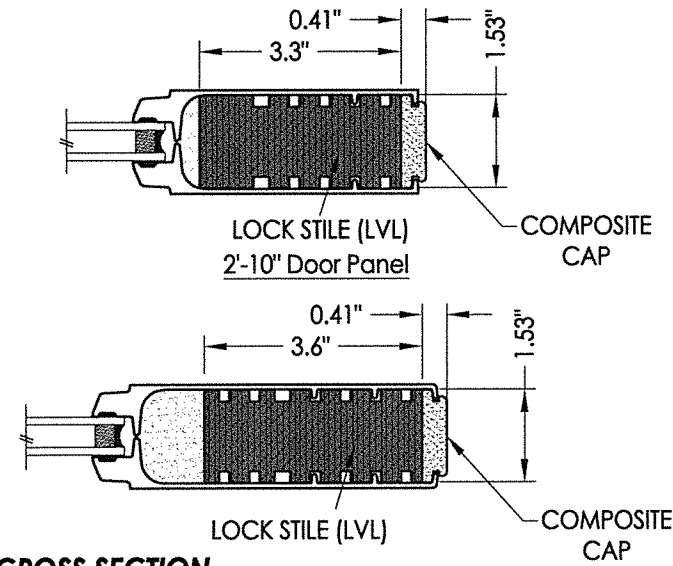

46 DOOR PANEL BOOK

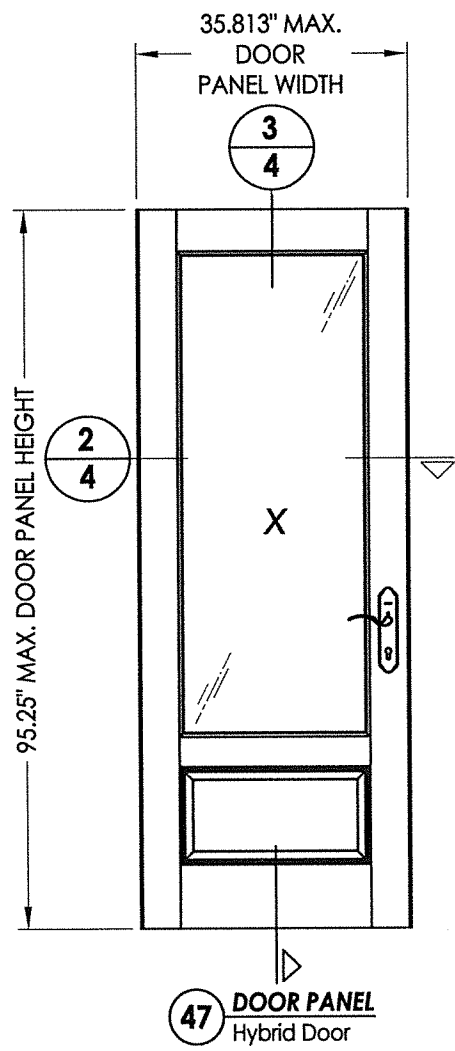

47 DOOR PANEL Hybrid Door

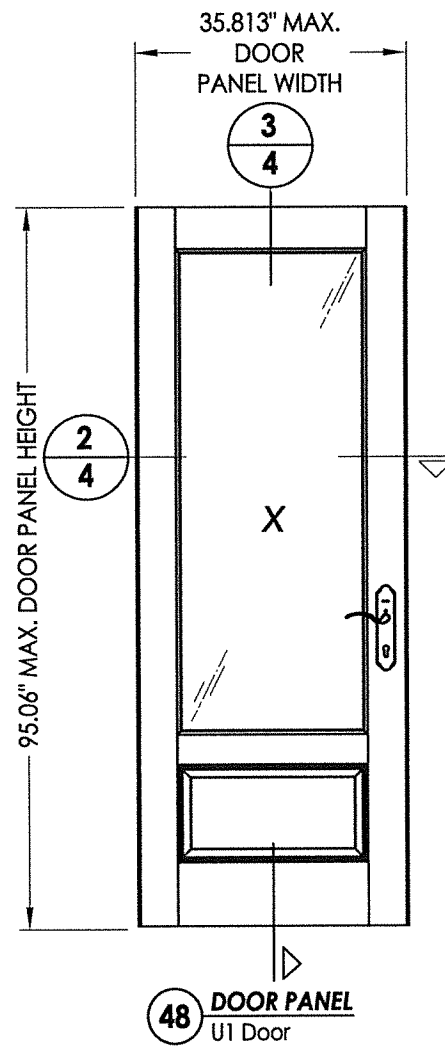

48 DOOR PANEL U1 Door

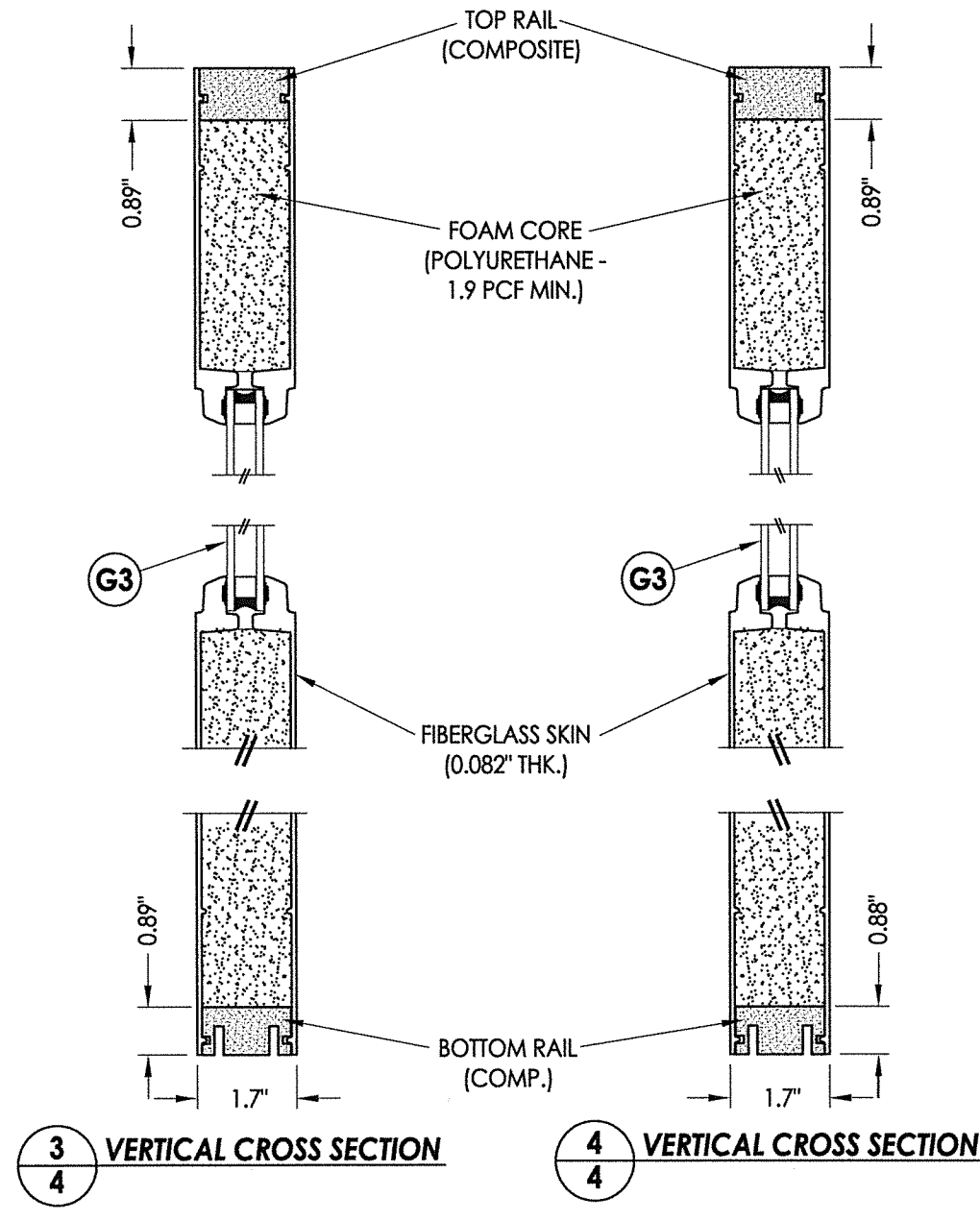

3
4 VERTICAL CROSS SECTION

4
4 VERTICAL CROSS SECTION

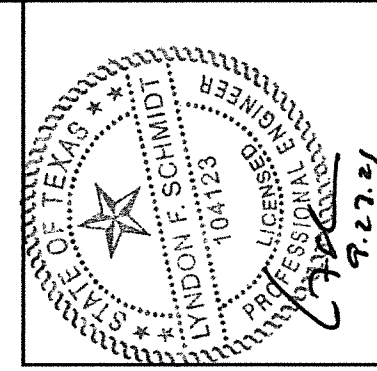

Documents Prepared By: Lyndon F. Schmidt, P.E.
TEXAS P.E. #104123

RW BUILDING CONSULTANTS, INC.
P.O. Box 230 Valrico FL 33595
Phone No.: 813.659.9197

TEXAS BOARD OF PROFESSIONAL ENGINEERS
CERTIFICATE OF REGISTRATION # F-11852

PRODUCT: THERMA-TRU FIBERGLASS DOOR

PART OR ASSEMBLY: DOOR PANEL DETAILS

REVISIONS	
NO.	DATE
1	9/23/21
	UPDATE TO 2018 IBC/IRC CODE
	LFS BY

DATE: 11/29/17
SCALE: N.T.S.
DWG. BY: JK
CHK. BY: LFS
DRAWING NO.: TX-4754
SHEET 4 OF 14

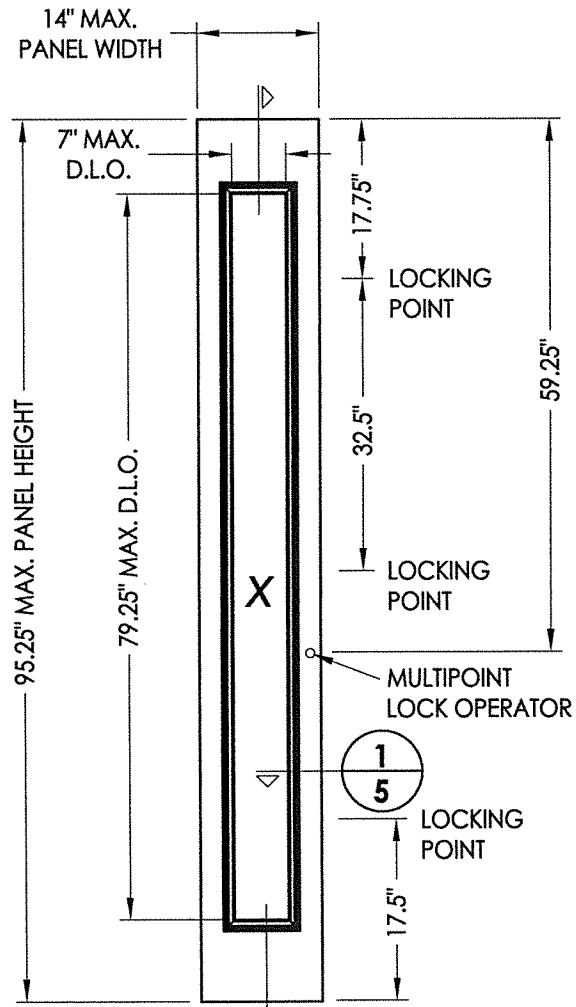

50 **SIDELITE PANEL**
VENTED

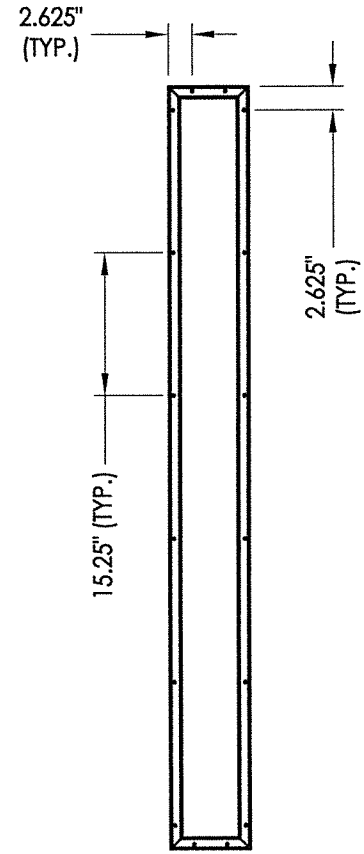

BTS Full Lite Frame

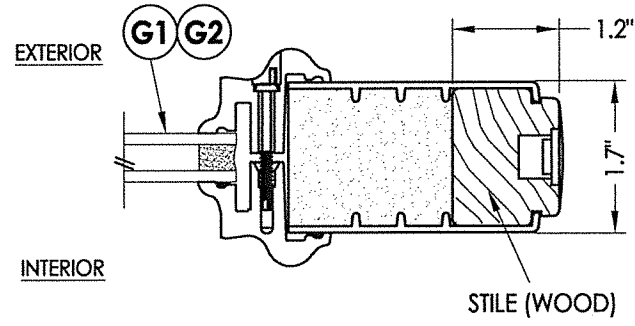

1 **HORIZONTAL CROSS SECTION**
5 Lip Lite Glazing

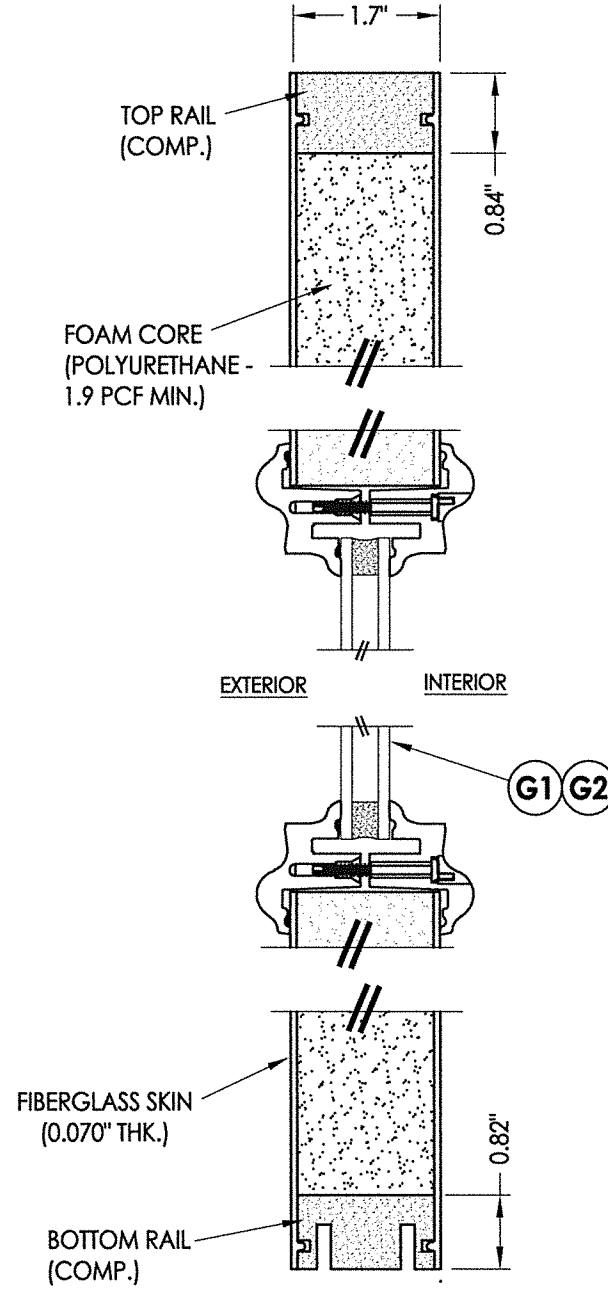

2 **VERTICAL CROSS SECTION**
5

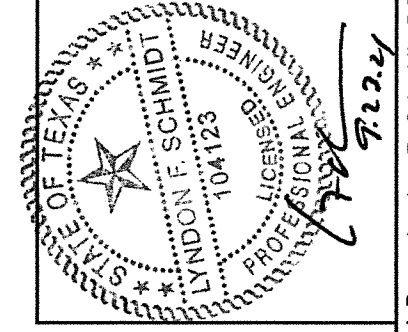

Documents Prepared By: Lyndon F. Schmidt, P.E.
TEXAS P.E. #104123

RW BUILDING CONSULTANTS, INC.
P.O. Box 230 Vairico FL 33595
Phone No.: 813.659.9197
TEXAS BOARD OF PROFESSIONAL ENGINEERS
CERTIFICATE OF REGISTRATION # F-11852

PRODUCT: THERMA-TRU

PART OR ASSEMBLY:
SIDELITE PANEL DETAILS

REVISIONS	
NO.	DATE
1	9/23/21
	UPDATE TO 2018 IBC/IRC CODE
LFS	BY

DATE: 11/29/17

SCALE: N.T.S.

DWG. BY: JK

CHK. BY: LFS

DRAWING NO.: TX-4754

SHEET 5 OF 14

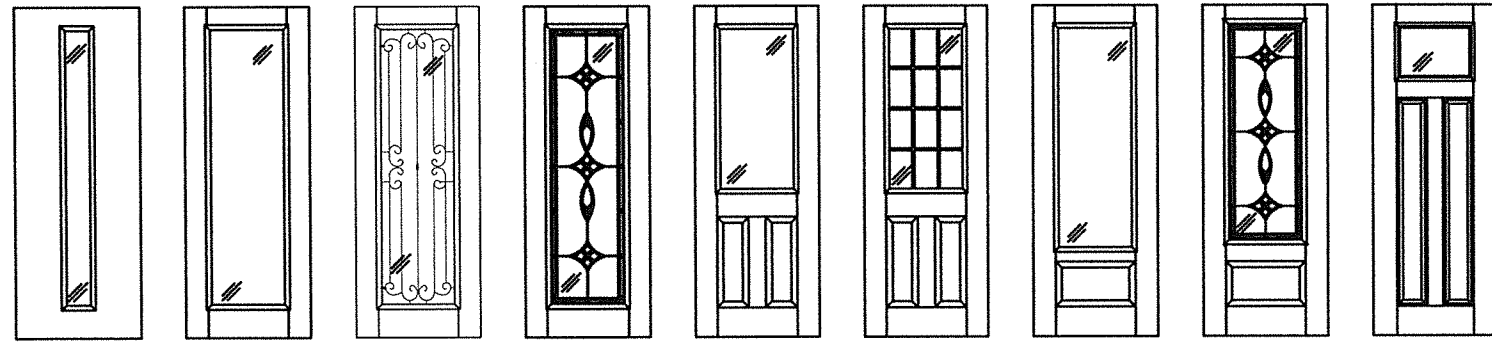
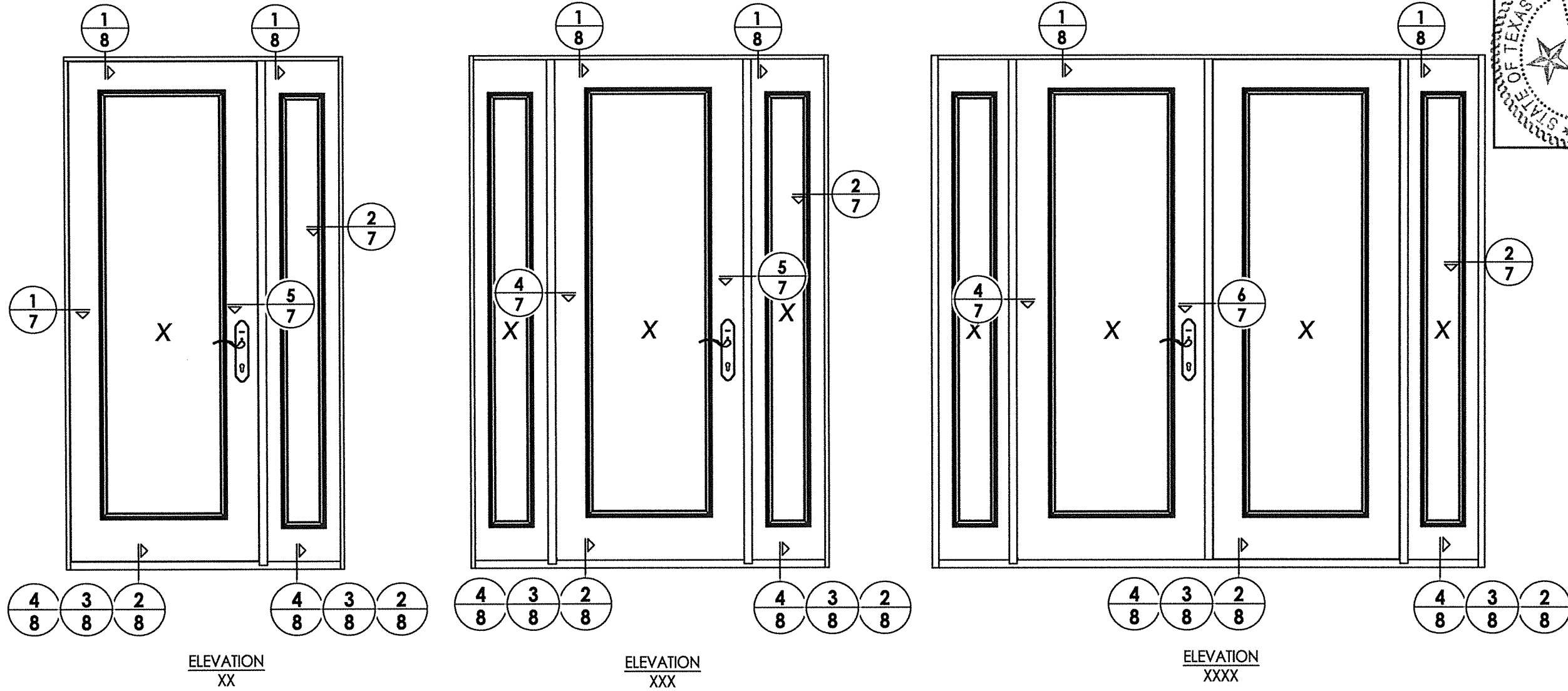

Fiber-Classic/Smooth-Star Door Panel Options
 Panel options shown are for illustration and are representative only
 (similar glazed panel configurations are allowed)

HARDWARE TABLE	
MANUFACTURER	MODEL
HOPPE	MULTIPOINT: HLS 9000 SERIES (Door) OSL SERIES (Sidelite)

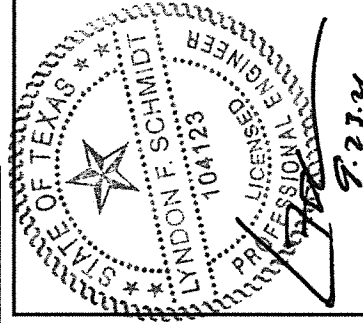

Documents Prepared By: Lyndon F. Schmidt, P.E.
 TEXAS P.E. #104123

RW BUILDING CONSULTANTS, INC.
 P.O. Box 230 Vairico FL 33595
 Phone No.: 813.659.9197

TEXAS BOARD OF PROFESSIONAL ENGINEERS
 CERTIFICATE OF REGISTRATION # F-11852

PRODUCT: THERMA-TRU

PART OR ASSEMBLY: ELEVATIONS

NO.	DATE	REVISIONS
1	9/23/21	UPDATE TO 2018 IBC/IRC CODE
		LFS
		BY

DATE: 11/29/17

SCALE: N.T.S.

DWG. BY: JK

CHK. BY: LFS

DRAWING NO.: TX-4754

SHEET 6 OF 14

Z:\Clients\Therma Tru PERMANENT\B - Texas Dept of Ins\TDI - DR 948 - 6'8 & 8'0 Glazed FG NonImp IS Vented Sidelites (TX 4753-4754)\C - Drawings\TX-4754.dwg

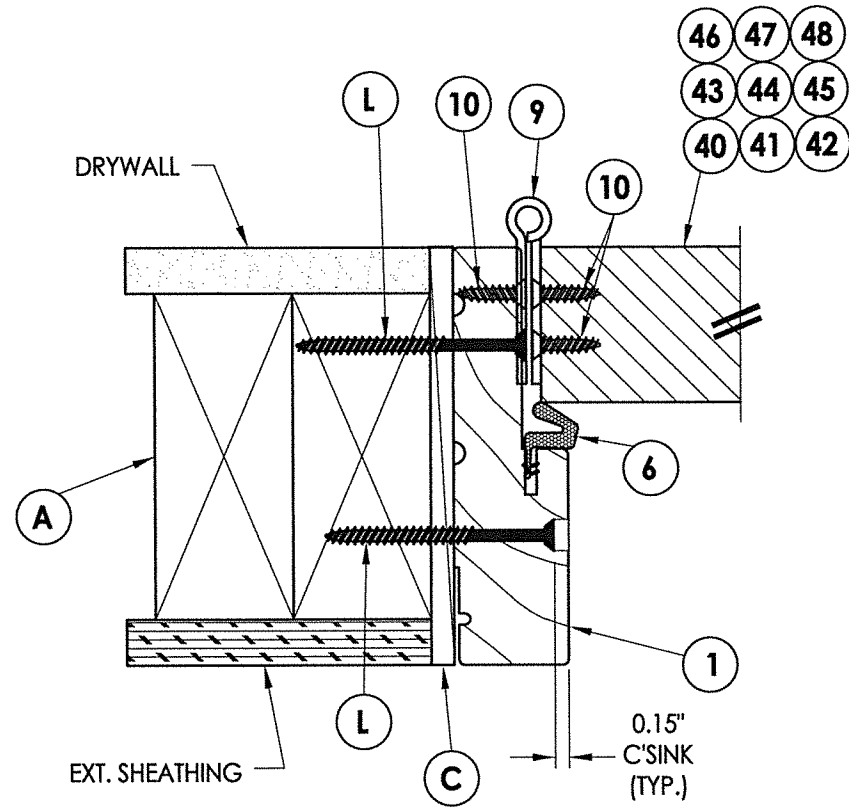

1
7 HORIZONTAL CROSS SECTION

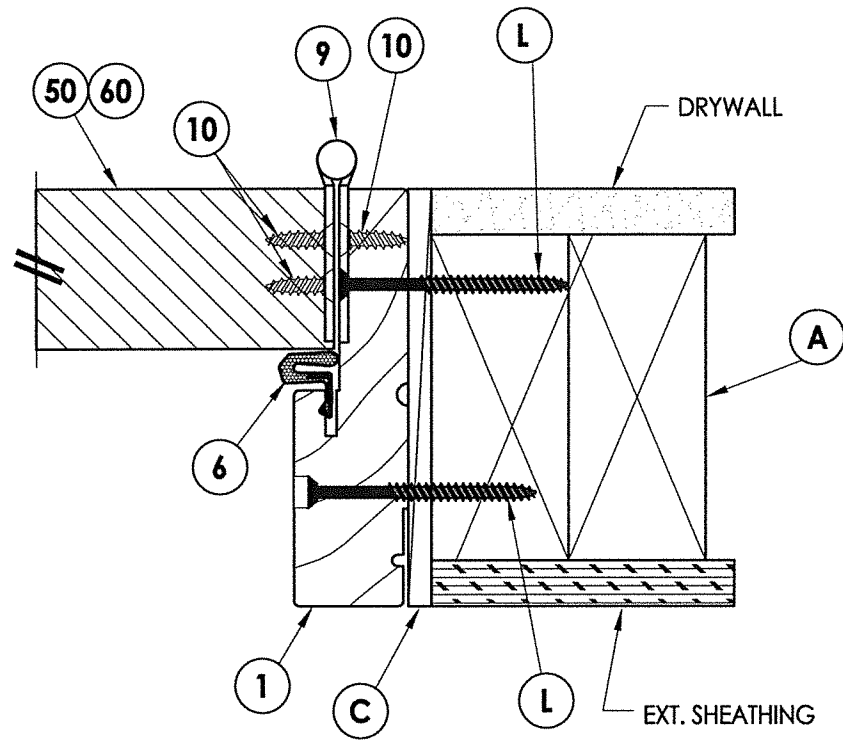

3
7 HORIZONTAL CROSS SECTION

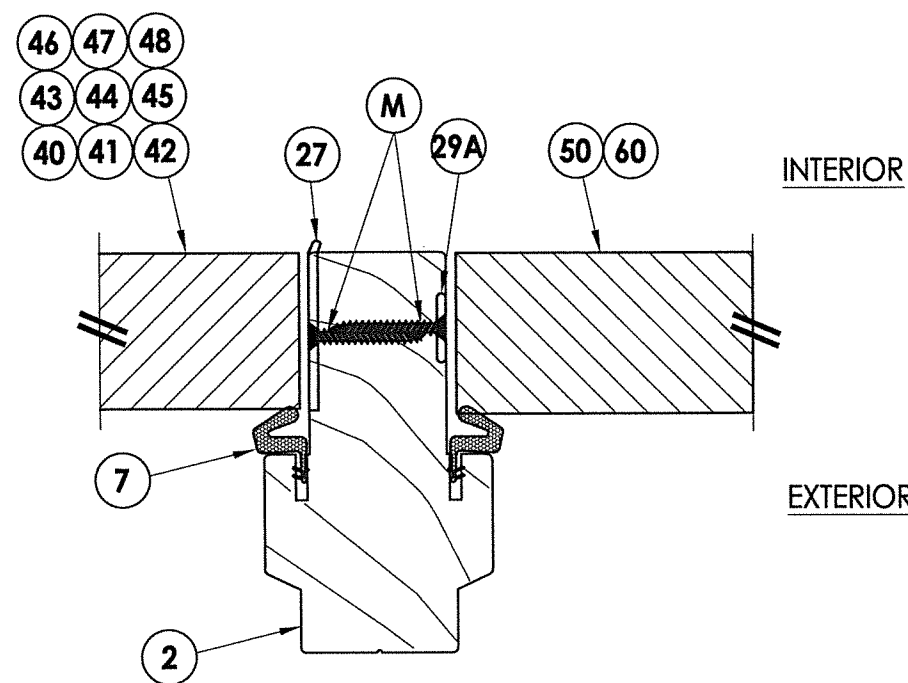

2
7 HORIZONTAL CROSS SECTION

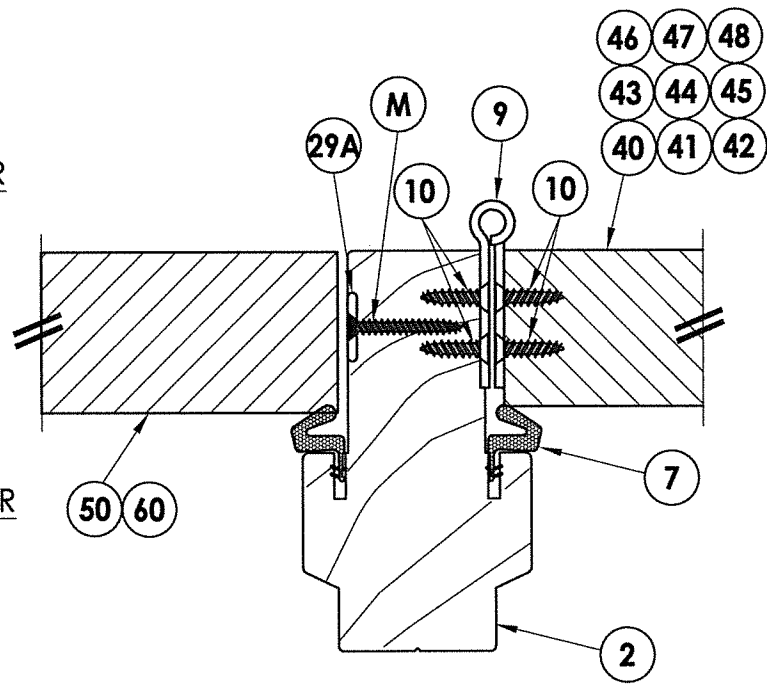

4
7 HORIZONTAL CROSS SECTION

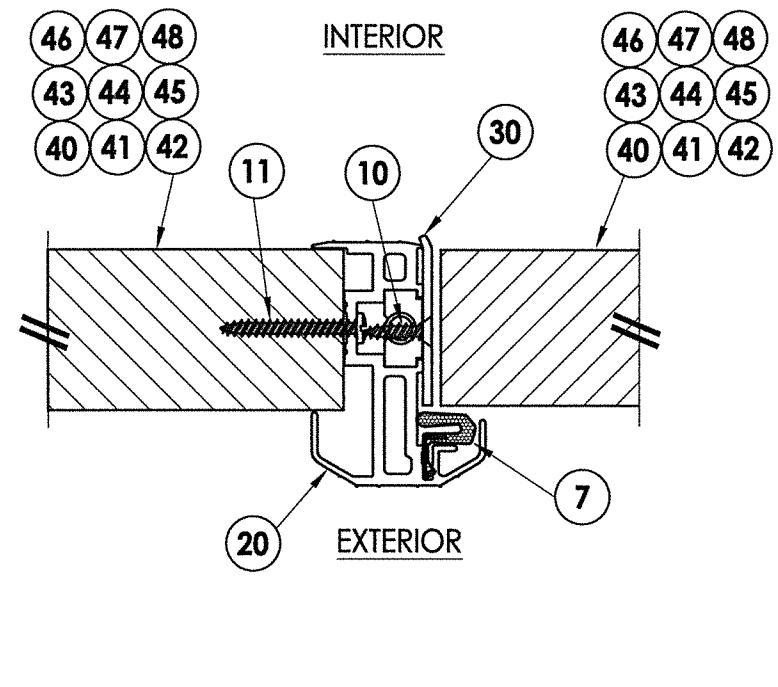

5
7 HORIZONTAL CROSS SECTION

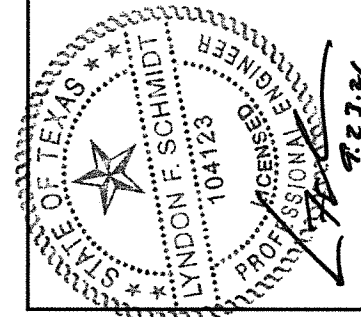

Documents Prepared By: Lyndon F. Schmidt, P.E.
TEXAS P.E. #104123

RW BUILDING CONSULTANTS, INC.
P.O. Box 230 Valrico FL 33595
Phone No.: 813.659.9197

TEXAS BOARD OF PROFESSIONAL ENGINEERS
CERTIFICATE OF REGISTRATION # F-11852

PRODUCT: THERMA-TRU

PART OR ASSEMBLY: HORIZONTAL CROSS SECTIONS

NO.	DATE	REVISIONS	BY
1	9/23/21	UPDATE TO 2018 IBC/IRC CODE	LFS

DATE: 11/29/17
SCALE: N.T.S.
DWG. BY: JK
CHK. BY: LFS
DRAWING NO.: TX-4754
SHEET 7 OF 14

Z:\Clients\Therma Tru PERMANENT\B - Texas Dept of Ins\TDI - DR 948 - 6'8 & 8'0 Glazed FG NonImp IS Vented Sidelites (TX 4753-4754)\C - Drawings\TX-4754.dwg

Notes:

- 1. Sill Item #'s 32, 34, 35, 36, 37, 38 & 39 are attached to jambs w/ (3) #8 X 2-1/2" pfh screws at each end.
- Sill Item # 33 is attached to jambs w/ (2) #8 X 2-1/2" pfh screws at each end.
- Sill Item #15 is attached to jambs utilizing (2) #10 X 2" pph SMS at each end.

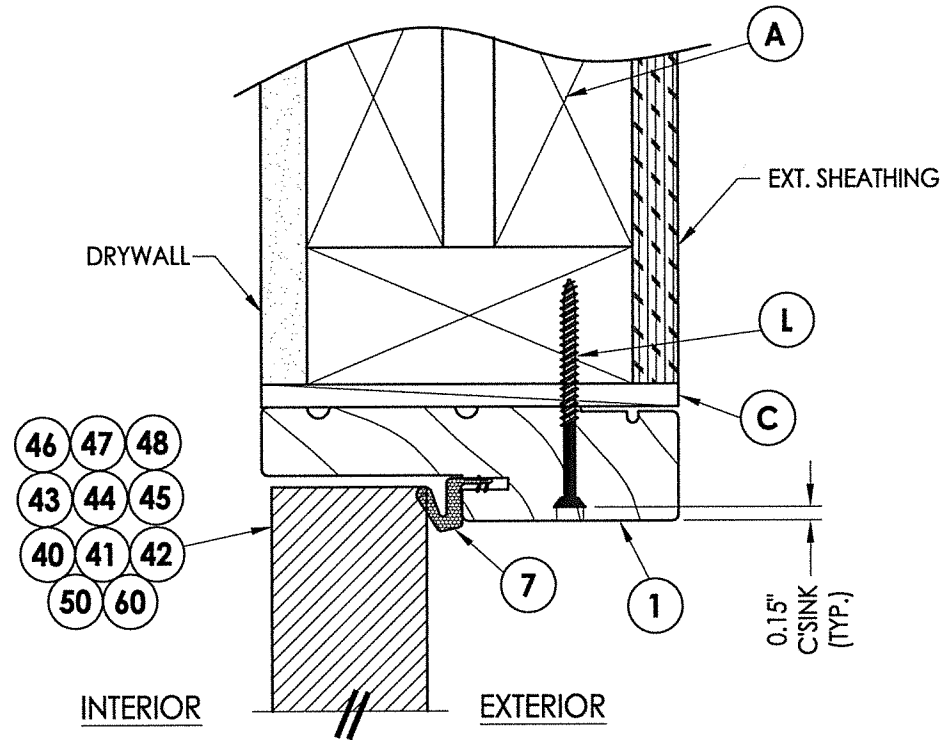

1 VERTICAL CROSS SECTION
8

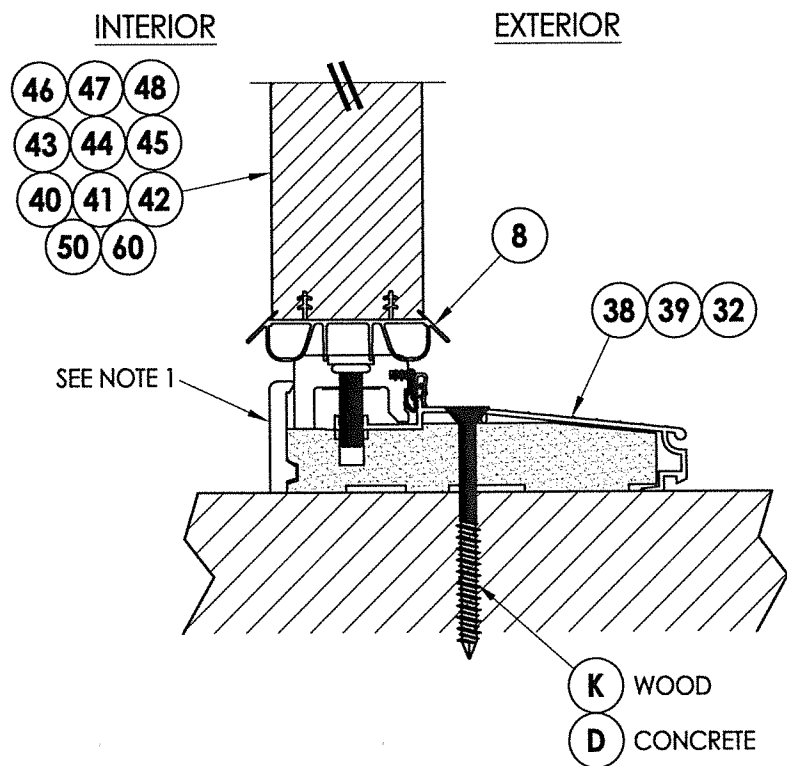

2 VERTICAL CROSS SECTION
8 Inswing Sill

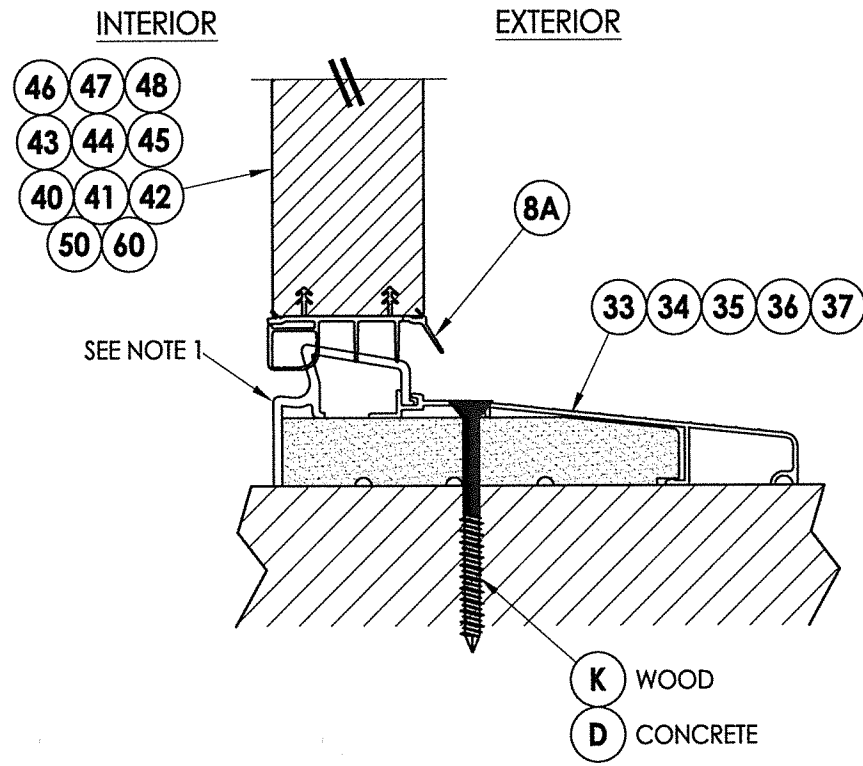

3 VERTICAL CROSS SECTION
8 Inswing Sill

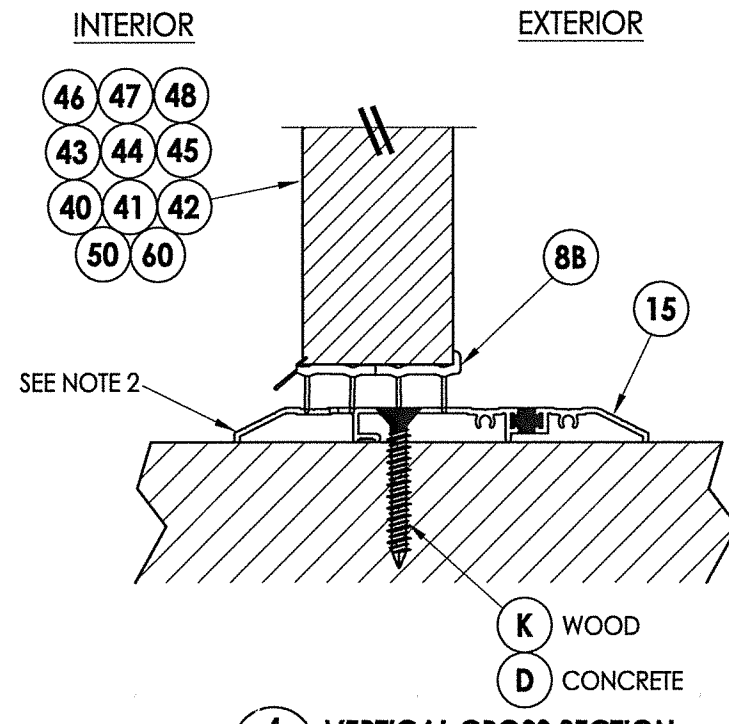

4 VERTICAL CROSS SECTION
8 Public Access Sill

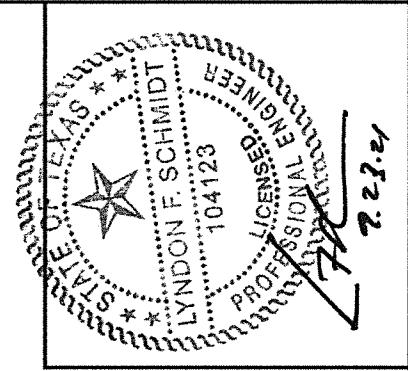

Documents Prepared By: Lyndon F. Schmidt, P.E.
TEXAS P.E. #104123

RW BUILDING CONSULTANTS, INC.
P.O. Box 230 Valrico FL 33595
Phone No.: 813.659.9197
TEXAS BOARD OF PROFESSIONAL ENGINEERS
CERTIFICATE OF REGISTRATION # F-11852

PRODUCT: THERMA-TRU

PART OR ASSEMBLY: VERTICAL CROSS SECTIONS

NO.	DATE	BY	LFS
1	9/23/21	DATE	UPDATE TO 2018 IBC/IRC CODE

DATE: 11/29/17
SCALE: N.T.S.
DWG. BY: JK
CHK. BY: LFS
DRAWING NO.: TX-4754
SHEET 8 OF 14

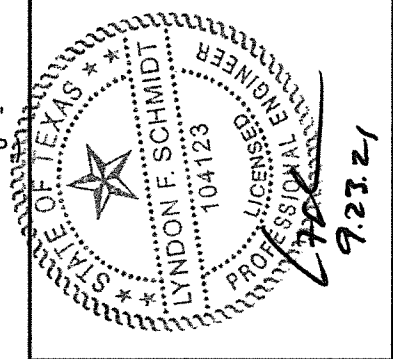
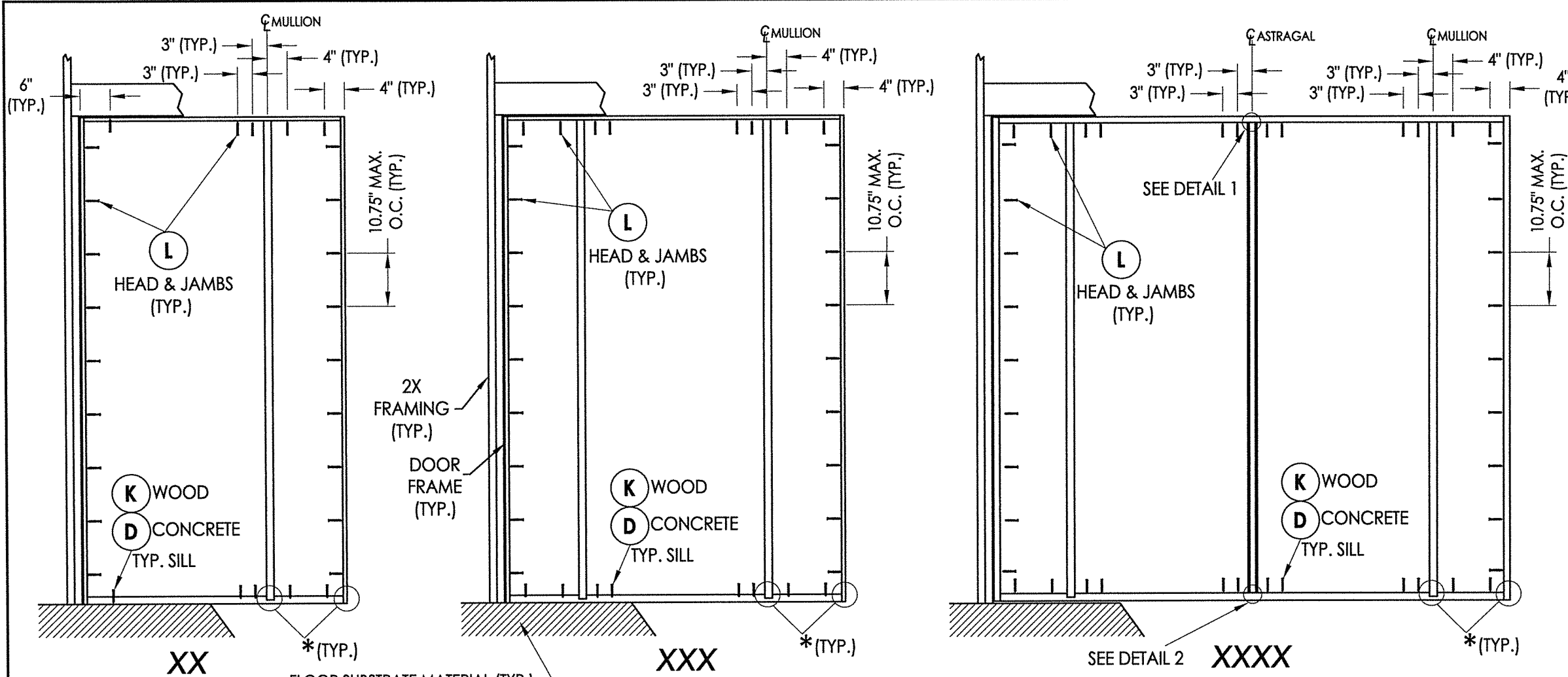

Documents Prepared By: Lyndon F. Schmidt, P.E.
TEXAS P.E. #104123

RW BUILDING CONSULTANTS, INC.
P.O. Box 230 Valrico FL 33595
Phone No.: 813.659.9197

TEXAS BOARD OF PROFESSIONAL ENGINEERS
CERTIFICATE OF REGISTRATION # F-11852

FLOOR SUBSTRATE MATERIAL (TYP.)
CONCRETE (MIN. 3000 PSI)
WOOD (S.G. >= 0.42)

FRAME ANCHORING

* The frame jambs and vertical mullions are secured to the head and sill with (3) #8 x 2-1/2" wood screws each.

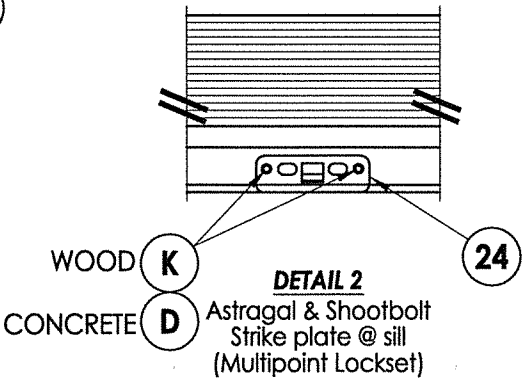
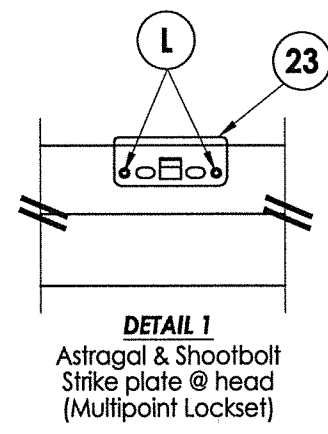
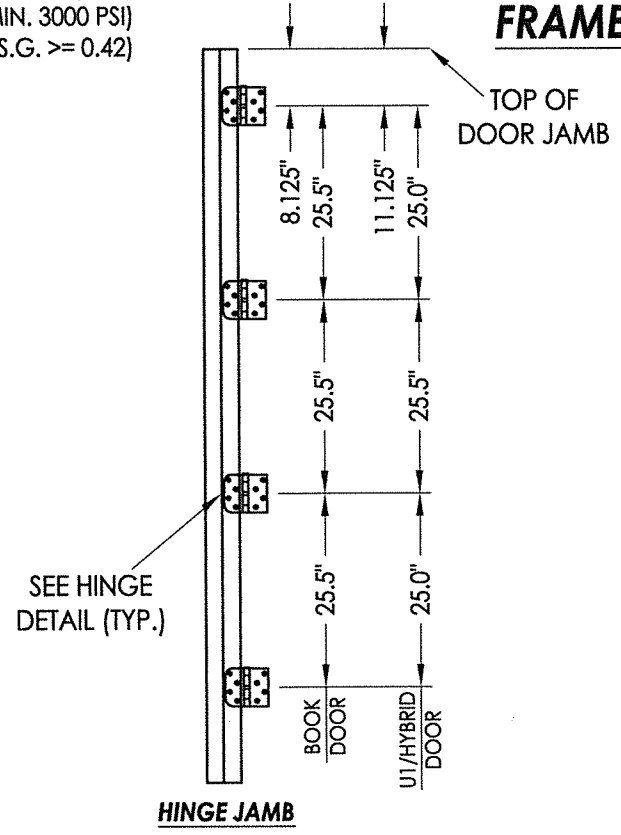
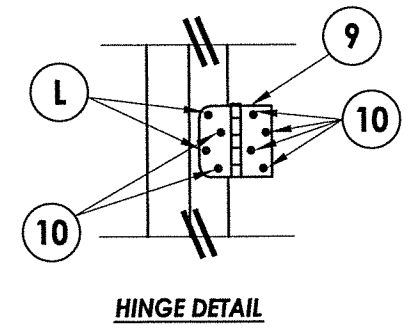

PRODUCT:	Therma-TRU
PART OR ASSEMBLY:	FRAME ANCHORING

NO.	DATE	BY
1	9/23/21	LFS

DATE:	11/29/17
SCALE:	N.T.S.
DWG. BY:	JK
CHK. BY:	LFS
DRAWING NO.:	TX-4754
SHEET	9 OF 14

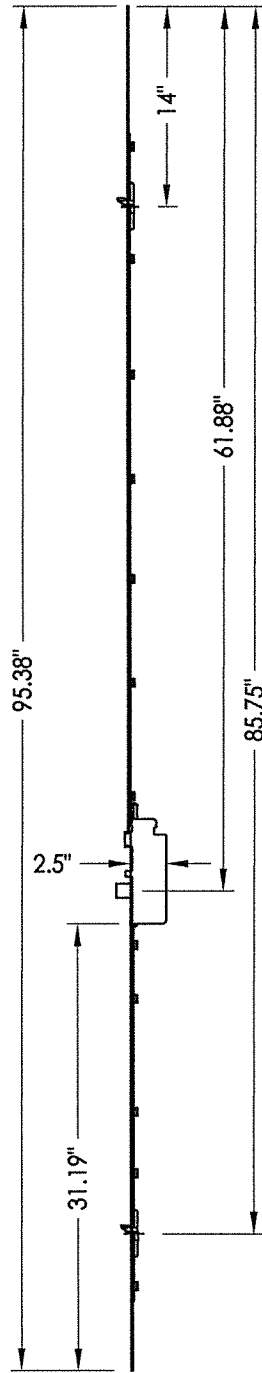
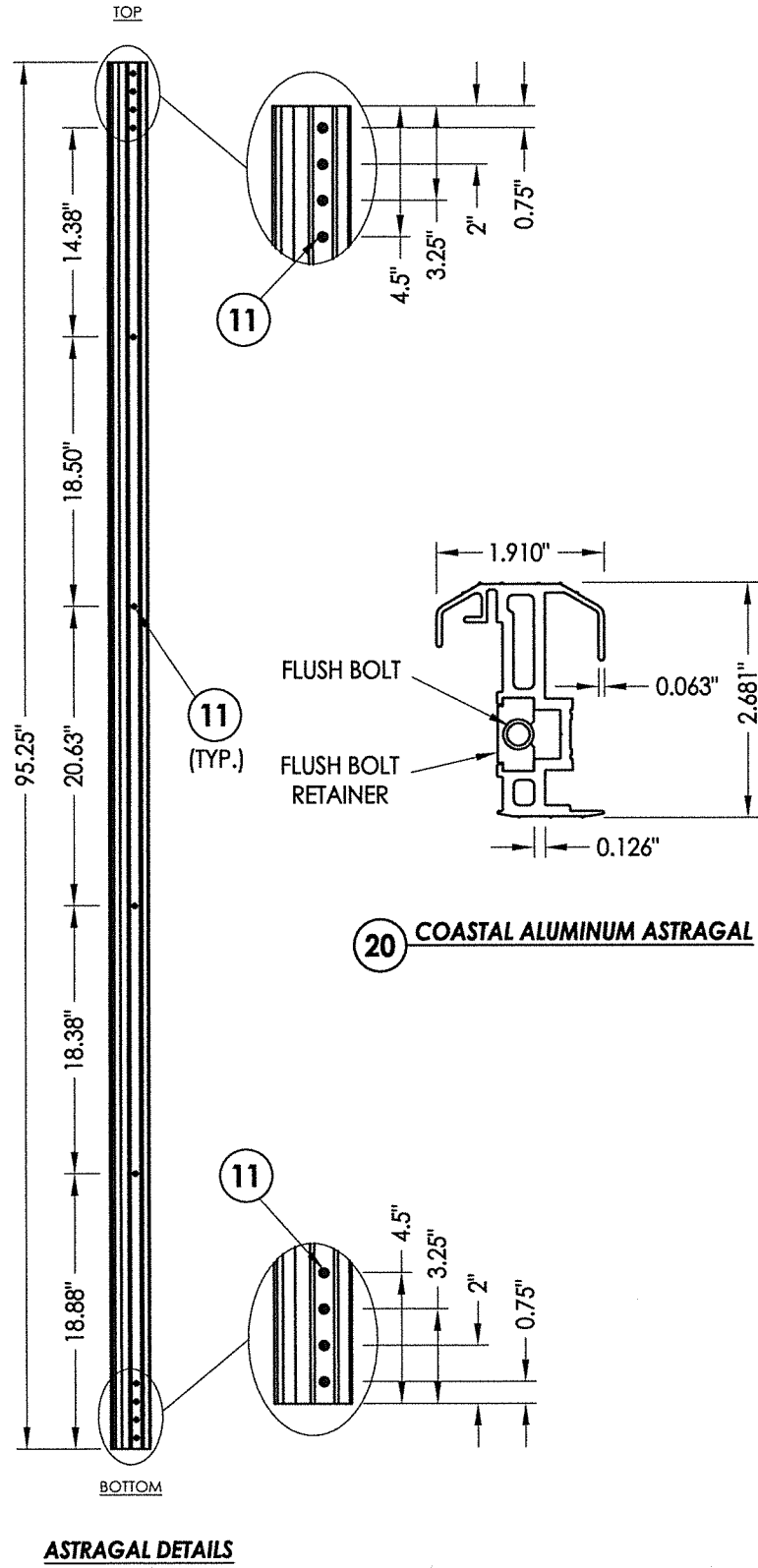

HOPPE MULTIPOINT LOCK
Manual Raised Tongue
Gear System
(Single Door)

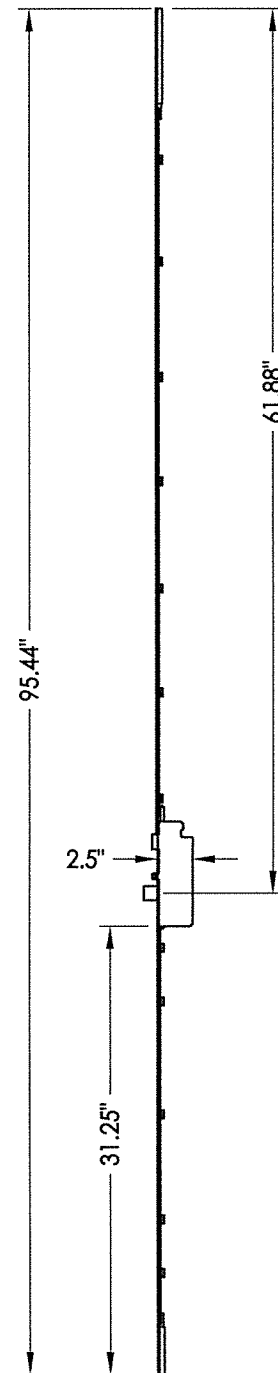

HOPPE MULTIPOINT LOCK
Manual Shootbolt System
(Double Door)

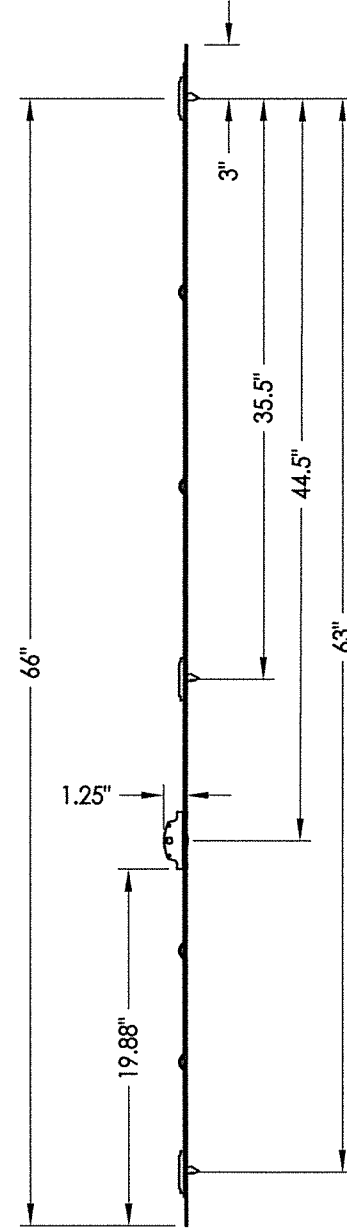

HOPPE MULTIPOINT LOCK
Manual Raised Tongue
Gear System
(Sidelite)

HOPPE MULTI-POINT LOCK SYSTEMS

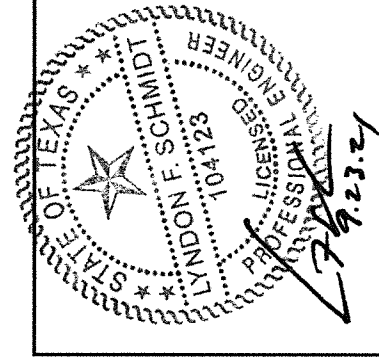

Documents Prepared By: Lyndon F. Schmidt, P.E.
TEXAS P.E. #104123

RW BUILDING CONSULTANTS, INC.
P.O. Box 230 Valrico FL, 33595
Phone No.: 813.659.9197

TEXAS BOARD OF PROFESSIONAL ENGINEERS
CERTIFICATE OF REGISTRATION # F-11852

PRODUCT: THERMA-TRU	
PART OR ASSEMBLY: HARDWARE DETAILS	
NO.	DATE
1	9/23/21
UPDATE TO 2018 IBC/IRC CODE	
LFS	BY
REVISIONS	
DATE: 11/29/17	
SCALE: N.T.S.	
DWG. BY: JK	
CHK. BY: LFS	
DRAWING NO.: TX-4754	
SHEET 10 of 14	

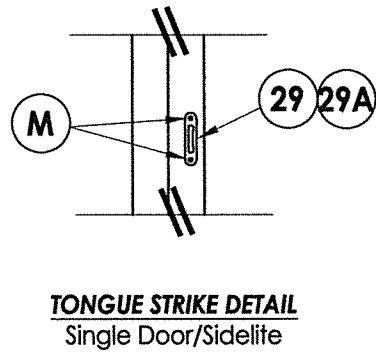

TONGUE STRIKE DETAIL
Single Door/Sidelite

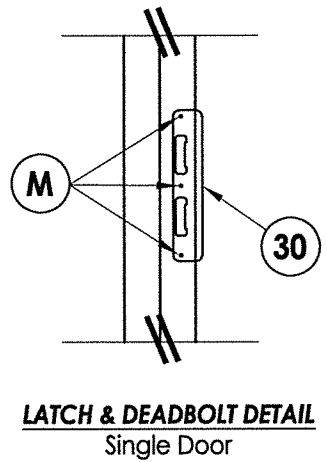

LATCH & DEADBOLT DETAIL
Single Door

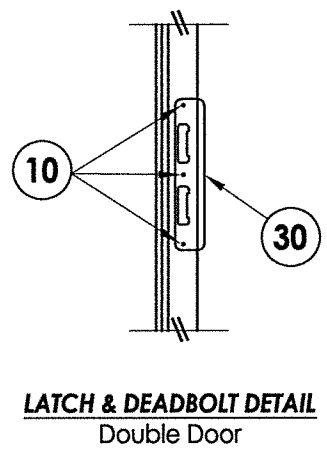

LATCH & DEADBOLT DETAIL
Double Door

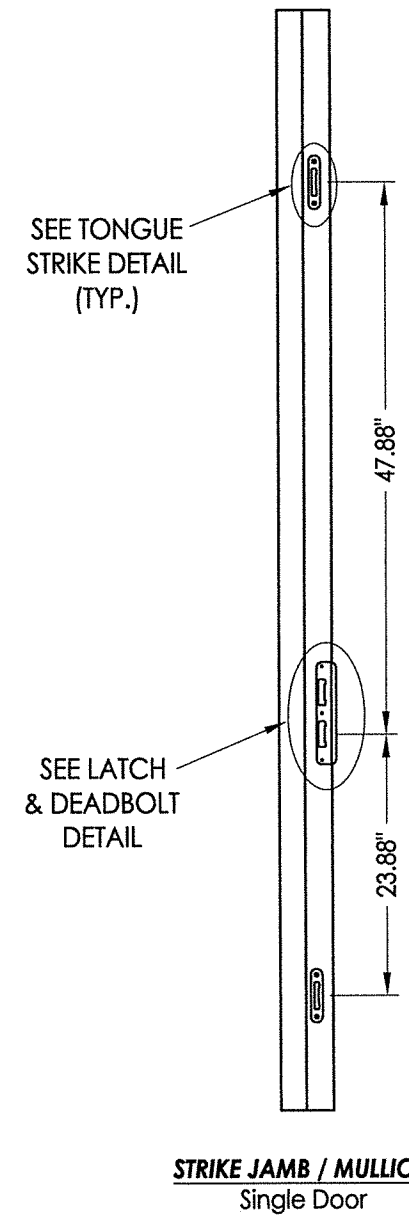

STRIKE JAMB / MULLION
Single Door

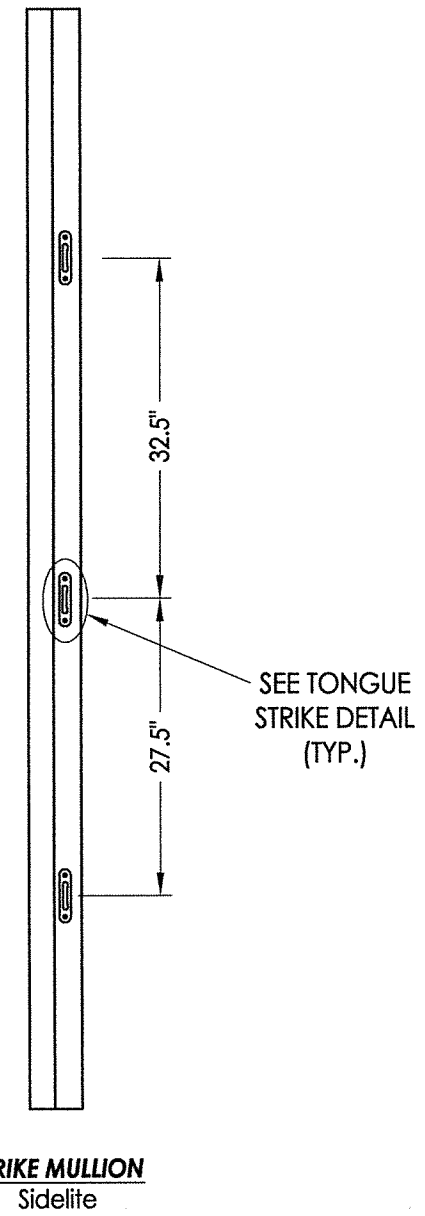

STRIKE MULLION
Sidelite

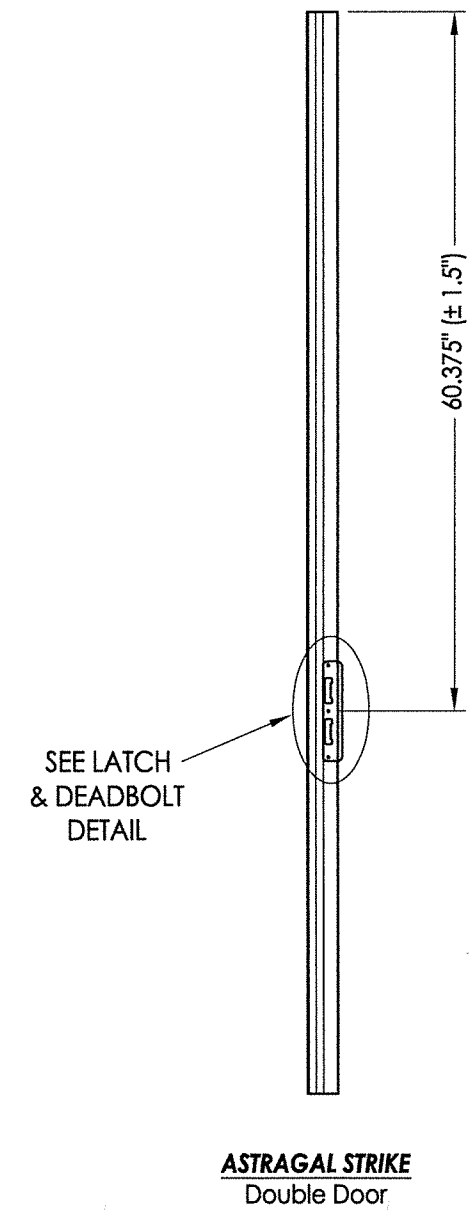

ASTRAGAL STRIKE
Double Door

MULTIPOINT LOCK STRIKE DETAILS

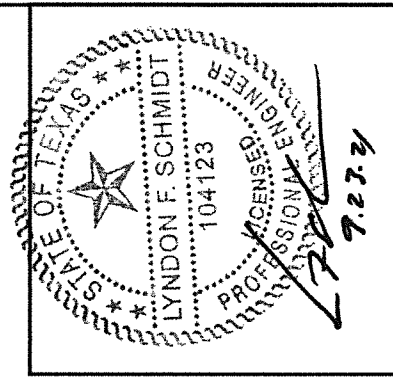

Documents Prepared By: Lyndon F. Schmidt, P.E.
TEXAS P.E. #104123

RW BUILDING CONSULTANTS, INC.
P.O. Box 230 Vairico FL 33595
Phone No.: 813.659.9197

TEXAS BOARD OF PROFESSIONAL ENGINEERS
CERTIFICATE OF REGISTRATION # F-11852

PRODUCT:		THERMA-TRU	
PART OR ASSEMBLY:		HARDWARE STRIKE DETAILS	
NO.	DATE	BY	REVISIONS
1	9/23/21	LFS	UPDATE TO 2018 IBC/IRC CODE
DATE: 11/29/17			
SCALE: N.T.S.			
DWG. BY: JK			
CHK. BY: LFS			
DRAWING NO.: TX-4754			
SHEET 11 OF 14			

Z:\Clients\Therma Tru PERMANENT\B - Texas Dept of Ins\TDI - DR 948 - 6'8 & 8'0 Glazed FG NonImp IS Vented Sidelites (TX 4753-4754)\C - Drawings\TX-4754.dwg

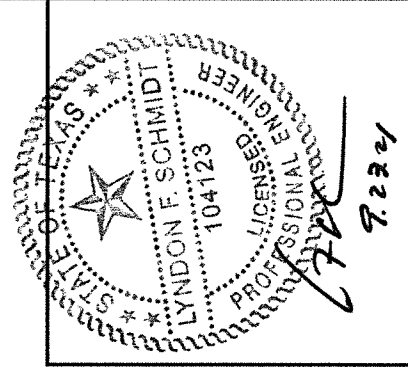

Documents Prepared By: Lyndon F. Schmidt, P.E.
TEXAS P.E. #104123

RW BUILDING CONSULTANTS, INC.
P.O. Box 230 Volico FL 33595
Phone No.: 813.659.9197

TEXAS BOARD OF PROFESSIONAL ENGINEERS
CERTIFICATE OF REGISTRATION # F-11852

PRODUCT: THERMA TRU FIBERGLASS DOOR

PART OR ASSEMBLY: GLAZING DETAILS

NO.	DATE	REVISIONS
1	9/23/21	UPDATE TO 2018 IBC/IRC CODE
		LFS
		BY

DATE: 11/29/17

SCALE: N.T.S.

DWG. BY: JK

CHK. BY: LFS

DRAWING NO.: TX-4754

SHEET 12 OF 14

© 2016 R.W. BUILDING CONSULTANTS INC.

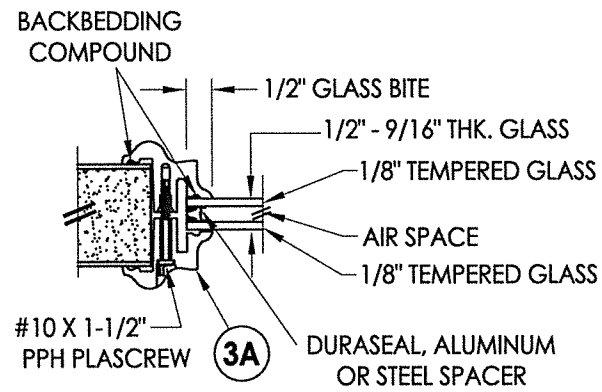

G1 GLAZING DETAIL
BTS Lite Frame
Door Panels

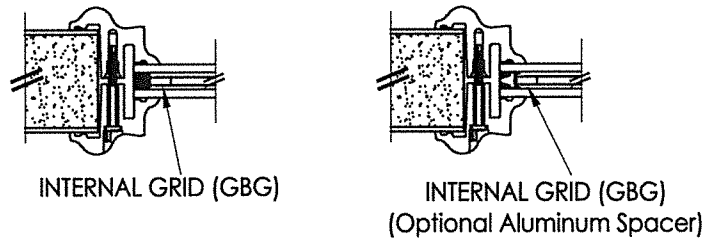

9/16" INSULATED GLASS INSERT OPTIONS

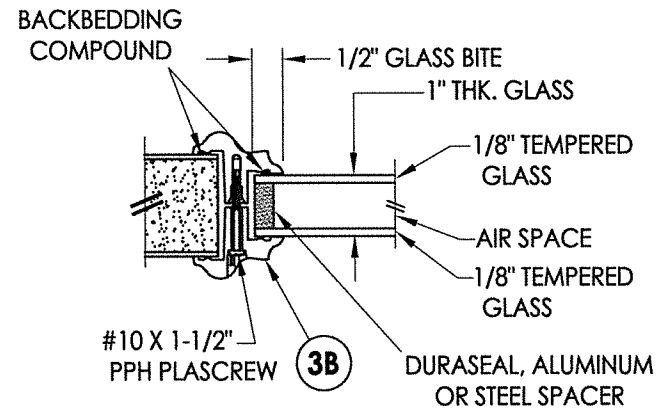

G2 GLAZING DETAIL
BTS Lite Frame
Door Panels

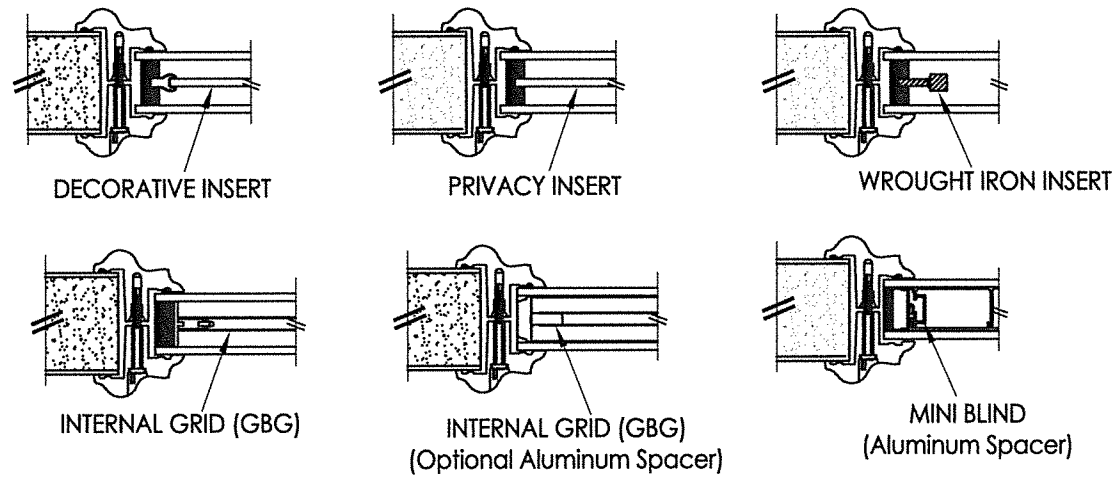

1" INSULATED GLASS INSERT OPTIONS

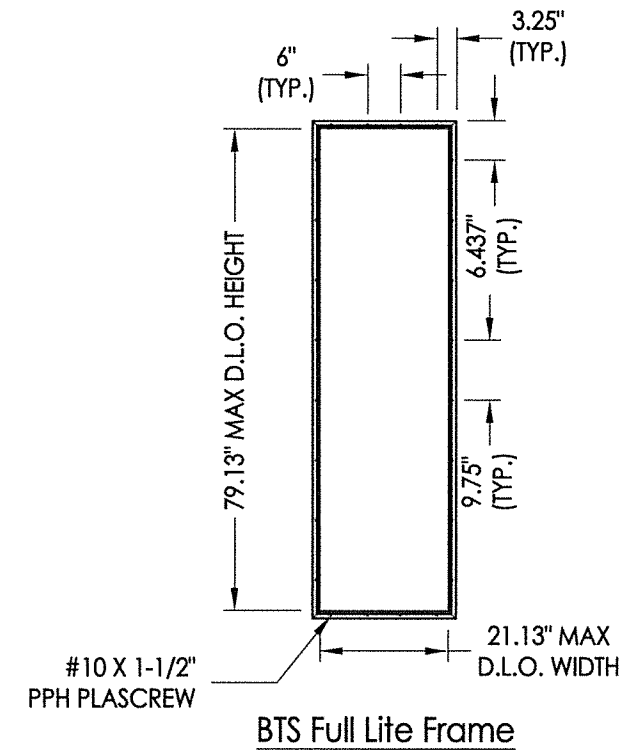

BTS Full Lite Frame

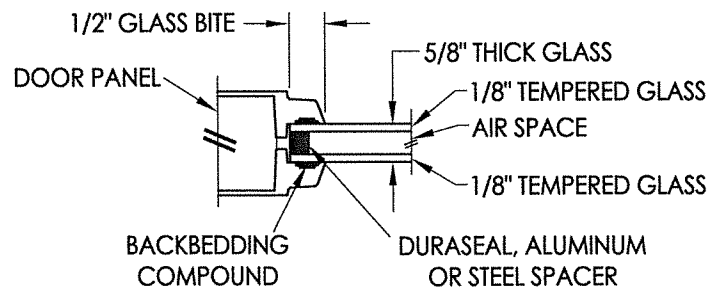

G3 GLAZING DETAIL
Flush Glazing
Door Panels

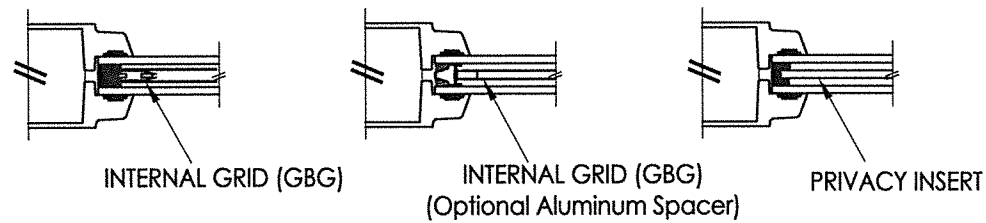

5/8" INSULATED GLASS INSERT OPTIONS

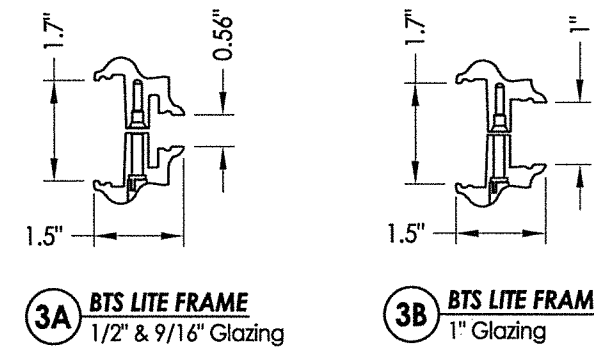

3A BTS LITE FRAME
1/2" & 9/16" Glazing

3B BTS LITE FRAME
1" Glazing

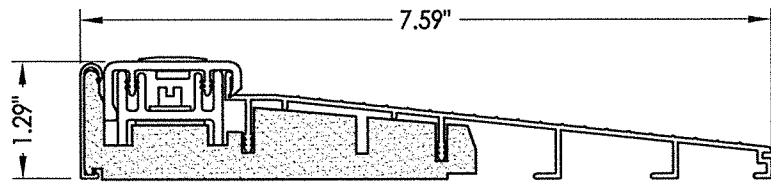

32 INSWING THRESHOLD
Inswing Basic Composite Adjustable Sill 7-1/2"

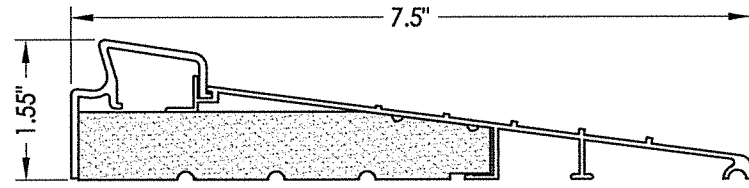

37 INSWING THRESHOLD
Inswing Basic Fixed 7-1/2" Sill

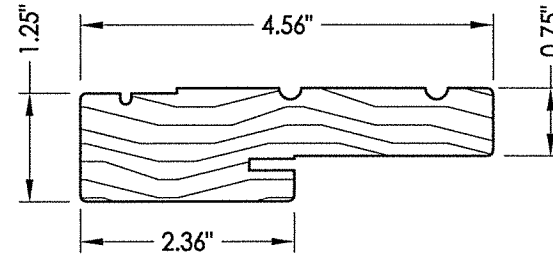

1 WOOD JAMB

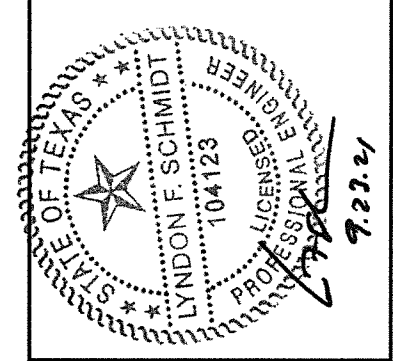

Documents Prepared By: Lyndon F. Schmidt, P.E.
TEXAS P.E. #104123

RW BUILDING CONSULTANTS, INC.
P.O. Box 230 Valrico FL 33595
Phone No.: 813.659.9197

TEXAS BOARD OF PROFESSIONAL ENGINEERS
CERTIFICATE OF REGISTRATION # F-11852

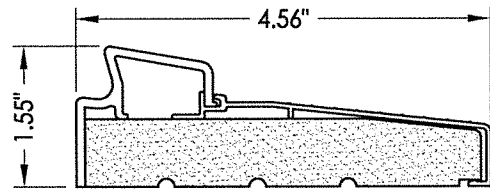

33 INSWING THRESHOLD
Inswing Basic Fixed Sill

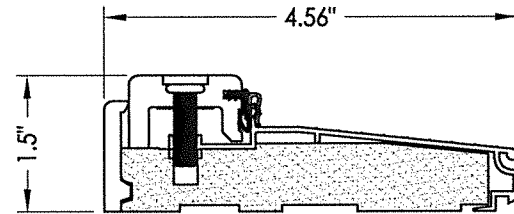

38 INSWING THRESHOLD
Inswing Composite Adjustable Sill

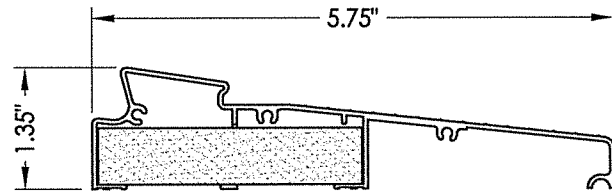

34 INSWING THRESHOLD
Inswing Moderate Climate Sill 1-3/8"

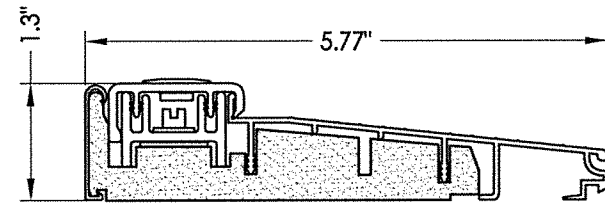

39 INSWING THRESHOLD
Inswing Basic Composite Adjustable Sill

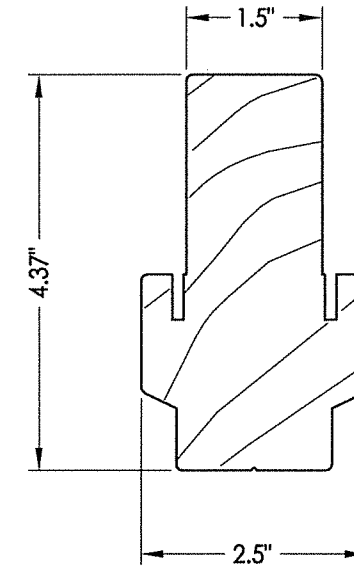

2 INTEGRAL MULLION

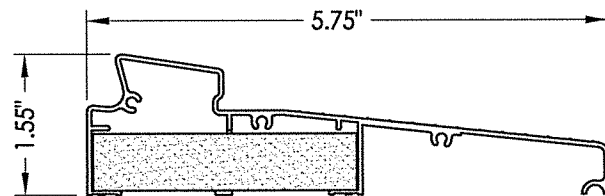

35 INSWING THRESHOLD
Inswing Moderate Climate Sill

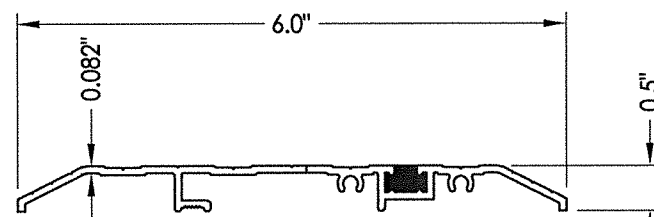

15 PUBLIC ACCESS THRESHOLD

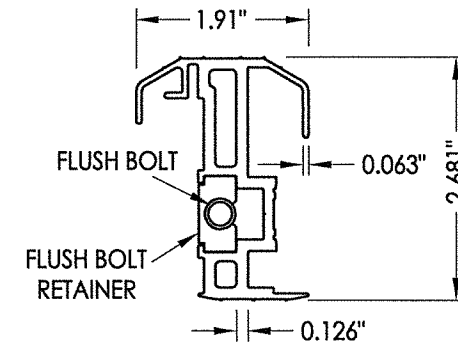

20 COASTAL ALUMINUM ASTRAGAL

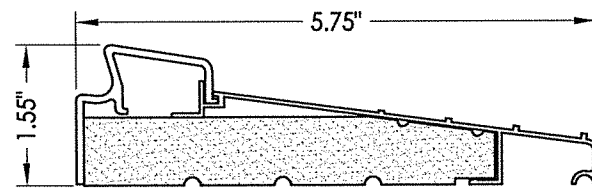

36 INSWING THRESHOLD
Inswing Basic Fixed 5-3/4" Sill

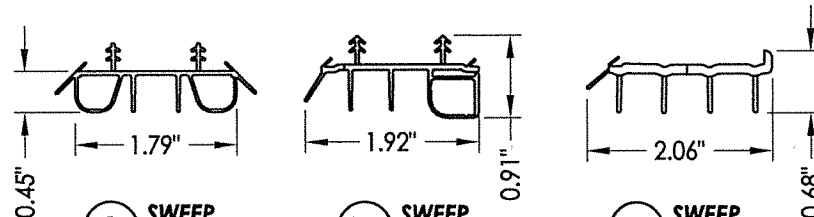

8 SWEEP

8A SWEEP

8B SWEEP

PRODUCT:		THERMA-TRU FIBERGLASS DOOR	
PART OR ASSEMBLY:		COMPONENTS	
NO.	DATE	DESCRIPTION	BY
1	9/23/21	UPDATE TO 2018 IBC/IRC CODE	LFS
REVISIONS			
DATE: 11/29/17			
SCALE: N.T.S.			
DWG. BY: JK			
CHK. BY: LFS			
DRAWING NO.: TX-4754			
SHEET 13 OF 14			

BILL OF MATERIALS		
ITEM #	DESCRIPTION	MATERIAL
A	2X FRAMING (SG >= 0.42)	WOOD
C	1/4" MAX. SHIM SPACE	-
D	1/4" PFH DeWALT OR ITW CONCRETE SCREW (1-3/4" MIN. EMBEDMENT)	STEEL
K	#12 PFH WOOD SCREW (1-1/2" MIN. EMBEDMENT)	STEEL
L	#10 X 2-1/2" PFH WOOD SCREW (1.15" MIN. EMBEDMENT)	STEEL
M	#8 X 1-1/4" PFH WOOD SCREW	STEEL
1	JAMB (FINGER JOINT PINE)	WOOD
2	INTEGRAL MULLION (PINE, SG >=0.42)	WOOD
6	WEATHERSTRIP (MEDIUM REACH)	FOAM
7	WEATHERSTRIP (LONG REACH)	FOAM
8	SWEEP	VINYL
8A	SWEEP (USE w/ MODERATE CLIMATE THRESHOLD)	VINYL
8B	SWEEP (USE w/ PUBLIC ACCESS THRESHOLD)	VINYL
9	4" X 4" HINGE	STEEL
10	#10 x 3/4" PFH WOOD SCREW	STEEL
11	#10 X 1-3/4" PFH WOOD SCREW	STEEL
15	PUBLIC ACCESS THRESHOLD	ALUM
20	COASTAL ALUMINUM ASTRAGAL	STEEL
23	ASTRAGAL & SHOOTBOLT STRIKE PLATE (AT HEAD)	STEEL
24	ASTRAGAL & SHOOTBOLT STRIKE PLATE (AT SILL)	STEEL
29	TONGUE STRIKE PLATE (DOOR TONGUE SYSTEM)	STEEL
29A	TONGUE STRIKE PLATE (SIDELITE TONGUE SYSTEM)	STEEL
30	LATCH & DEADBOLT STRIKE PLATE (TONGUE SYSTEM)	ALUM/COMP
31	MULTIPOINT STRIKE PLATE (TONGUE SYSTEM)	ALUM/COMP
32	INSWING THRESHOLD	ALUM/COMP
33	INSWING THRESHOLD	ALUM/COMP
34	INSWING THRESHOLD	ALUM/COMP
35	INSWING THRESHOLD	ALUM/COMP
36	INSWING THRESHOLD	ALUM/COMP
37	INSWING THRESHOLD	ALUM/COMP
38	INSWING THRESHOLD	ALUM/COMP
39	INSWING THRESHOLD	ALUM/COMP
40	DOOR PANEL (BOOK)	-
41	DOOR PANEL (HYBRID)	-
42	DOOR PANEL (U1)	-
43	DOOR PANEL (BOOK)	-
44	DOOR PANEL (HYBRID)	-
45	DOOR PANEL (U1)	-
46	DOOR PANEL (BOOK)	-
47	DOOR PANEL (HYBRID)	-
48	DOOR PANEL (U1)	-
50	SIDELITE	-

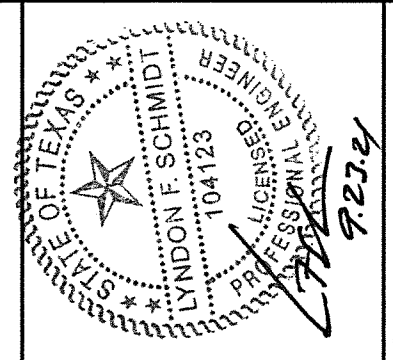

Documents Prepared By: Lyndon F. Schmidt, P.E.
TEXAS P.E. #104123

RW BUILDING CONSULTANTS, INC.
P.O. Box 230 Valrico FL 33595
Phone No.: 813.659.9197

TEXAS BOARD OF PROFESSIONAL ENGINEERS
CERTIFICATE OF REGISTRATION # F-11852

PRODUCT: THERMA-TRU FIBERGLASS DOOR

PART OR ASSEMBLY: BILL OF MATERIALS

NO.	DATE	REVISIONS
1	9/23/21	UPDATE TO 2018 IBC/IRC CODE
		LFS
		BY

DATE: 11/29/17
SCALE: N.T.S.
DWG. BY: JK
CHK. BY: LFS
DRAWING NO.: TX-4754
SHEET 14 of 14

CONCRETE ANCHOR NOTES:

- Concrete anchor locations at the corners may be adjusted to maintain the min. edge distance to mortar joints.
- Concrete anchor locations noted as "MAX. ON CENTER" must be adjusted to maintain the min. edge distance to mortar joints, additional concrete anchors may be required to ensure the "MAX. ON CENTER" dimension are not exceeded.
- Concrete anchor table:

ANCHOR TYPE	ANCHOR SIZE	MIN. EMBEDMENT	MIN. CLEARANCE TO MASONRY EDGE	MIN. CLEARANCE TO ADJACENT ANCHOR
ITW TAPCON®	1/4"	1-3/4"	2"	4"
DeWALT ULTRACON+®	1/4"	1-3/4"	1"	4"

WOOD SCREW INSTALLATION NOTES:

- Maintain a minimum 5/8" edge distance, 1" end distance, & 1" o.c. spacing of wood screws to prevent the splitting of wood.