



Glazed Steel Door

"NON-IMPACT"
INSWING / OUTSWING

EVALUATED FOR USE IN THE STATE OF TEXAS

The Glazed Steel Door system described herein complies with the 2018 International Residential Code (IRC), Sections R301 & R609 and the 2018 International Building Code (IBC), Sections 1404.13, 1609, 1709.5, 2403 and 2404 subject to the following conditions:

1. Anchors shall be as listed and spaced as shown in the details. Anchor embedment to base material shall be beyond wall dressing or stucco.
2. When used in areas requiring wind-borne debris protection this product is required to be protected with an impact resistant covering that complies with Section R301.2.1.2 of the IRC and Section 1609.2 of the IBC.
3. Allowable design pressure requirements must be equal to or less than the design pressure rating shown in the design pressure chart, sheet 1 of this drawing.
4. Conditions not covered by this drawing are subject to further engineering analysis.

TABLE OF CONTENTS	
SHEET #	DESCRIPTION
1	Typical elevations, design pressures & general notes
2	Door panel details
3	Slidette panel details (lip lite insert glazing)
4	Horizontal cross sections
5	Vertical cross sections
6	Vertical cross sections
7	Frame anchoring

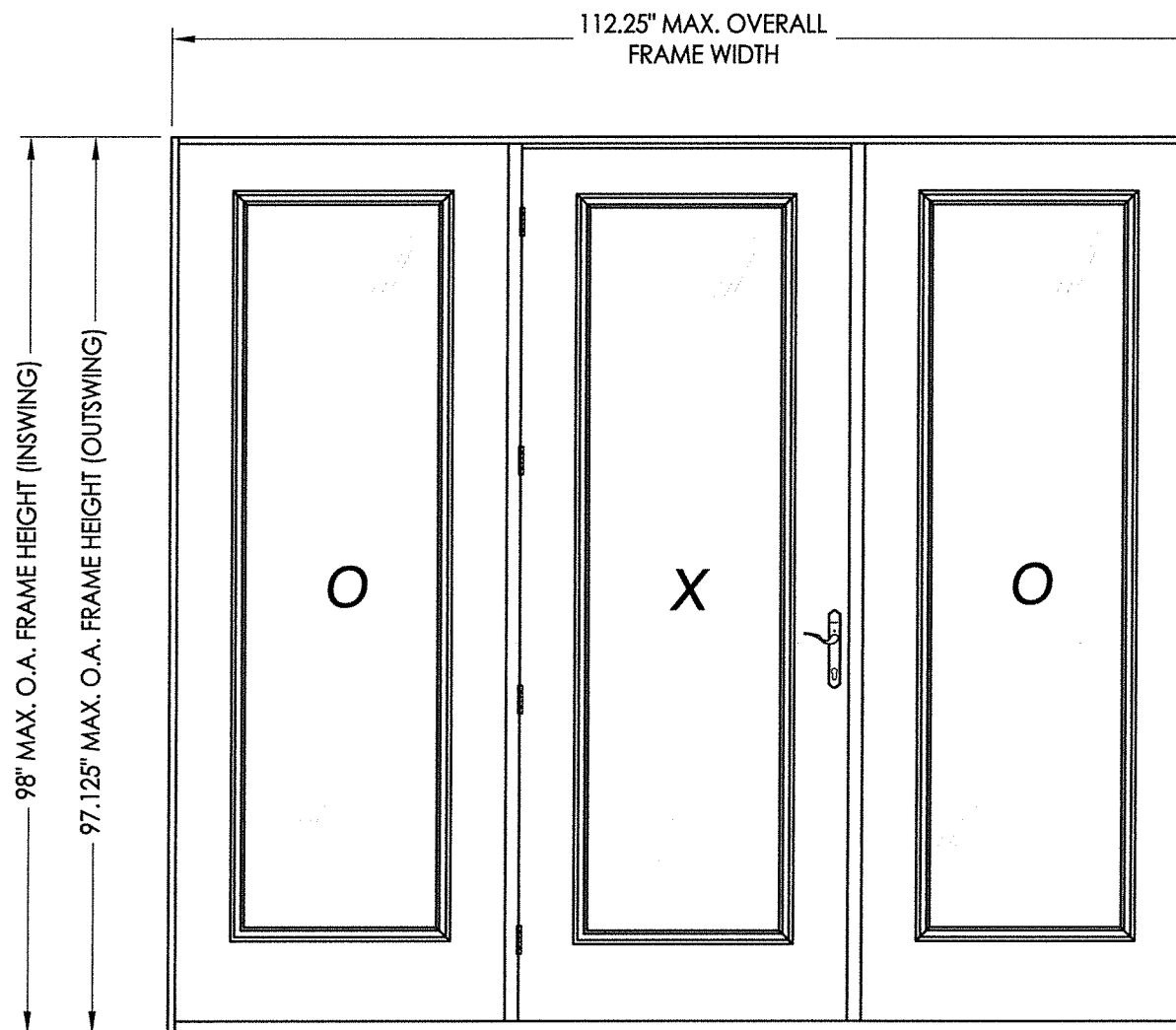

CONFIG.	MODEL	DESIGN PRESSURE (PSF)	
		POSITIVE	NEGATIVE
OXO	INSWING	+35.0	-35.0
OXO	OUTSWING	+45.0	-45.0

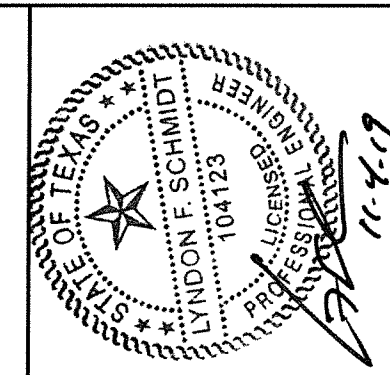

Documents Prepared By: Lyndon F. Schmidt, P.E.
TEXAS P.E. #104123

RW BUILDING CONSULTANTS, INC.
P.O. Box 230 Valrico FL 33595
Phone No.: 813.659.9197
TEXAS BOARD OF PROFESSIONAL ENGINEERS
CERTIFICATE OF REGISTRATION # F-11852

PRODUCT: ENDURA
PART OR ASSEMBLY:
TYPICAL ELEVATION, DESIGN PRESSURES & GENERAL NOTES

NO.	DATE	REVISIONS
1	10/23/19	ADD "FusionFrame" OPTION & UPDATE TO 2018 IBC/IRC CODE

DATE: 11/16/16
SCALE: N.T.S.
DWG. BY: JK
CHK. BY: LFS
DRAWING NO.: TX-4687
SHEET 1 OF 7

R:\Clients\Endura PERMANENT\B - Texas Dept of Ins\TDI - DR-864 Masonite ST Glazed (Trilennium)\C - Drawings\TX-4684.85.87.88.dwg, 2.4

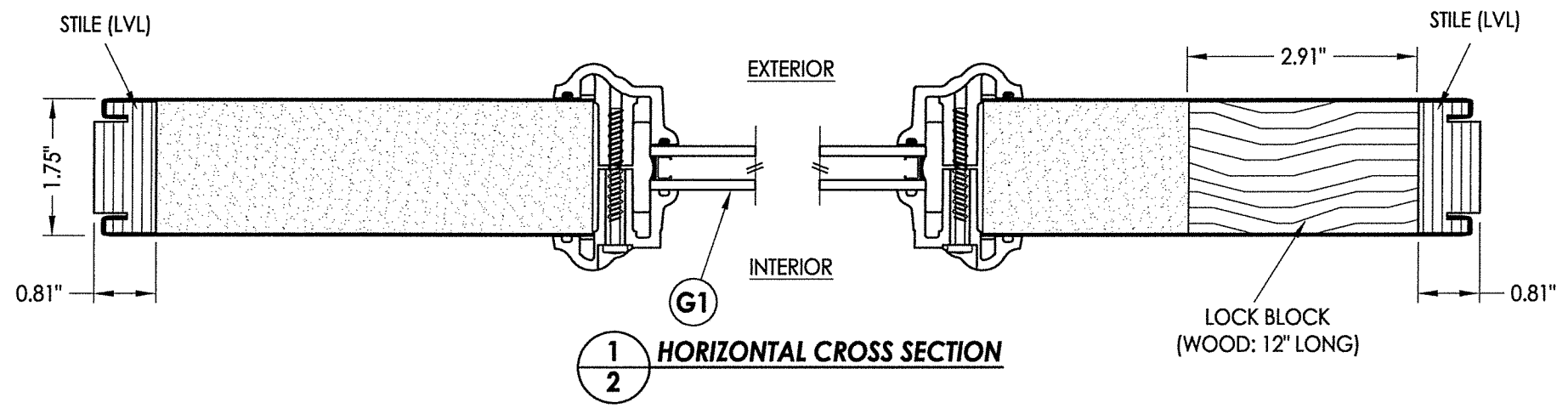

1
2 HORIZONTAL CROSS SECTION

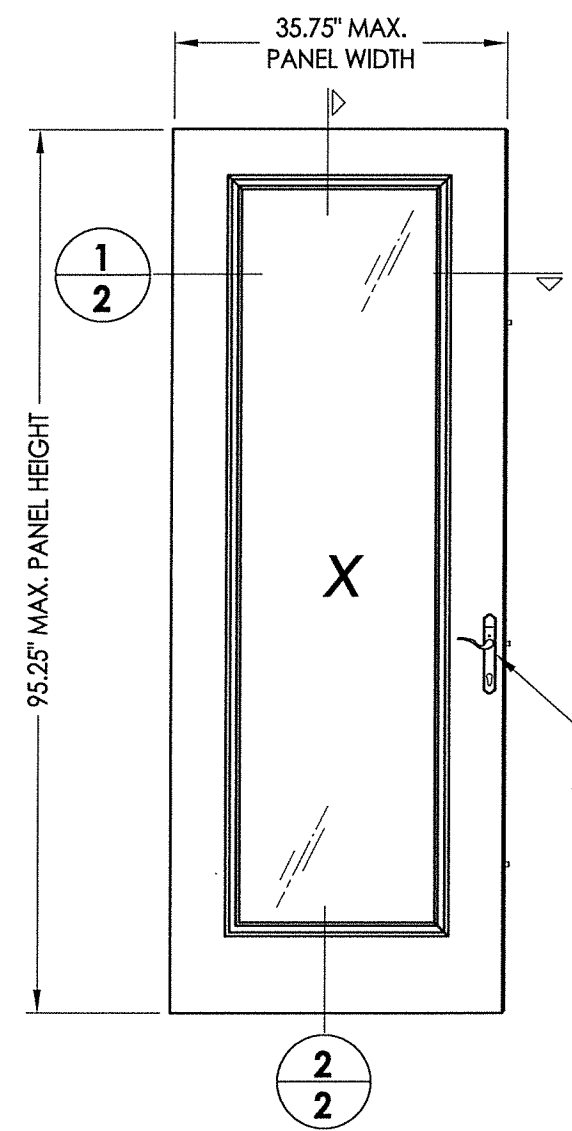

2
2 DOOR PANEL
Masonite
Steel (Wood Edge)

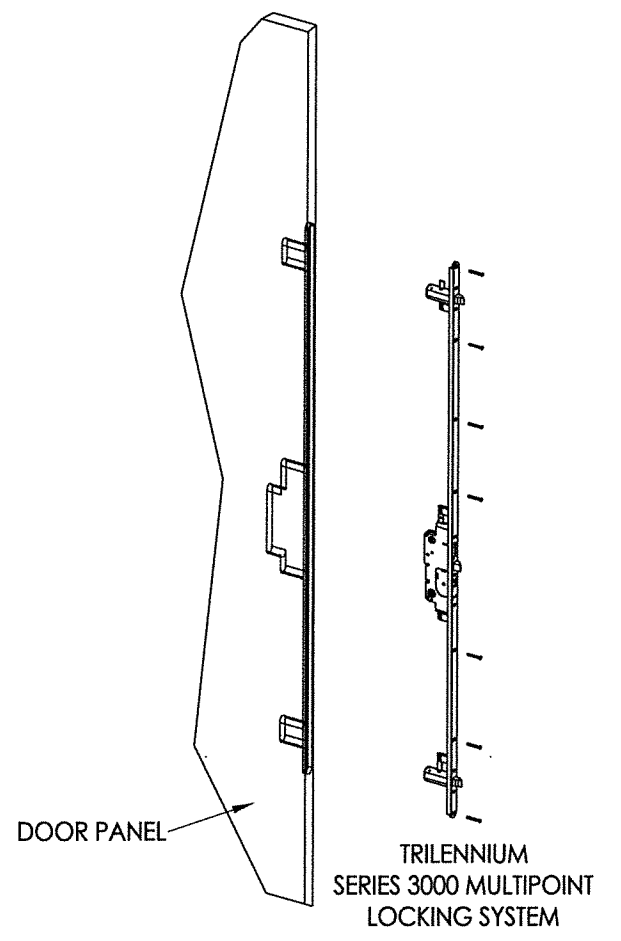

HARDWARE TABLE	
MANUFACTURER	MODEL
Endura	Trilennium® 3000 Series Multipoint lock (3pt.)

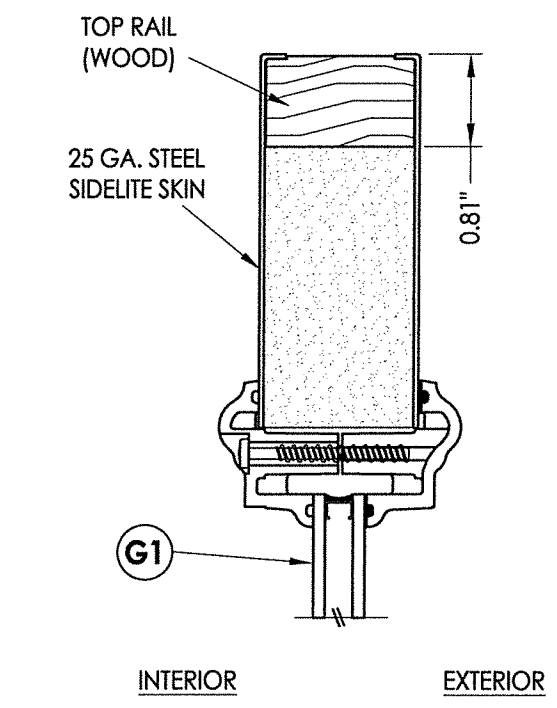

2
2 VERTICAL CROSS SECTION

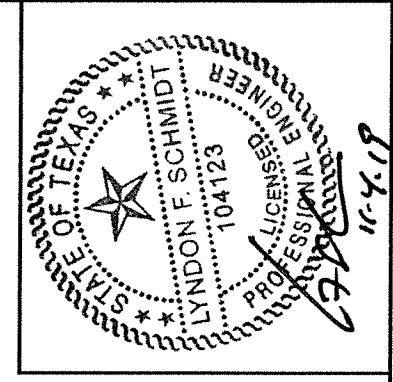

Documents Prepared By: Lyndon F. Schmidt, P.E.
TEXAS P.E. #104123

RW BUILDING CONSULTANTS, INC.
P.O. Box 230 Valrico FL, 33595
Phone No.: 813.659.9197

TEXAS BOARD OF PROFESSIONAL ENGINEERS
CERTIFICATE OF REGISTRATION # F-11852

PRODUCT:	ENDURA	
PART OR ASSEMBLY:	DOOR PANEL DETAILS & GLAZING DETAIL	
NO.	DATE	BY
1	10/23/19	LFS
ADD "FusionFrame" OPTION & UPDATE TO 2018 IBC/IRC CODE		
REVISIONS		
DATE:	11/16/16	
SCALE:	N.T.S.	
DWG. BY:	JK	
CHK. BY:	LFS	
DRAWING NO.:	TX-4687	
SHEET	2	OF 7

R:\Clients\Endura PERMANENT\B - Texas Dept of Ins\TDI - DR-864 Masonite ST Glazed (Trilennium)\C - Drawings\TX-4684.85.87.88.dwg, 3.4

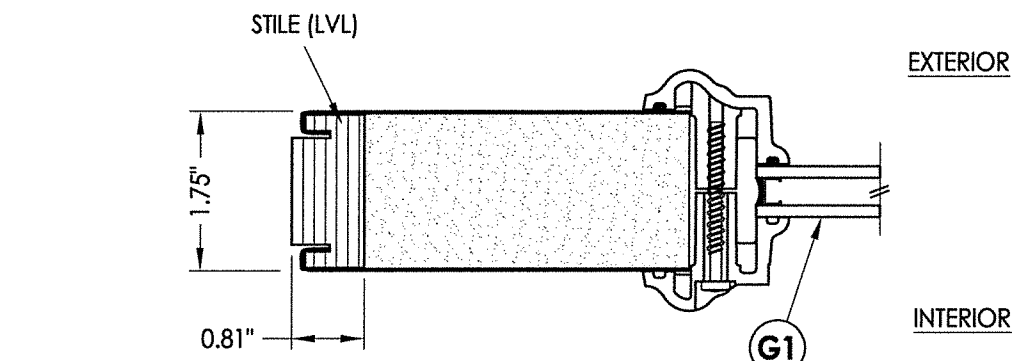

1
3 HORIZONTAL CROSS SECTION

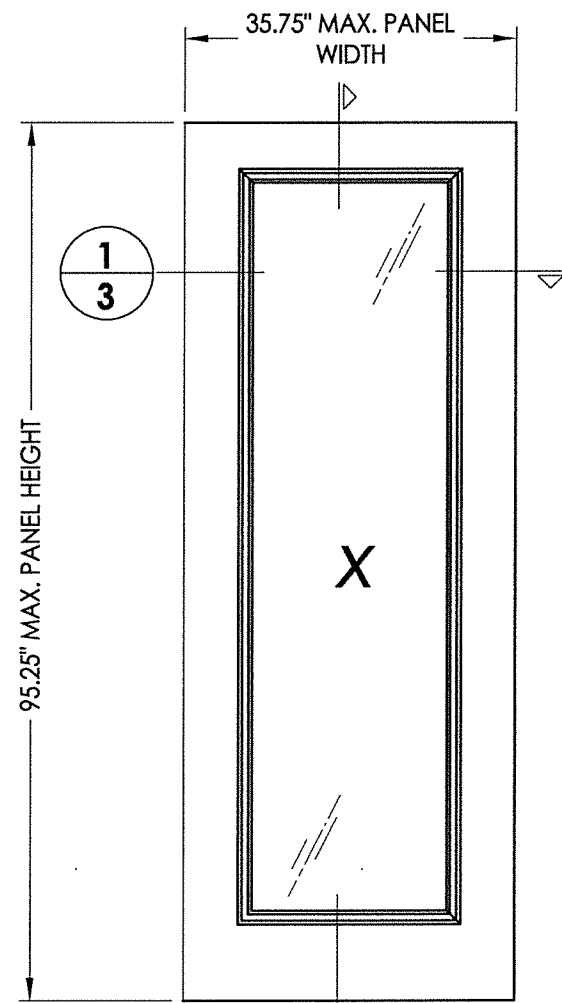

2
3
SIDELITE PANEL
Masonite
Steel (Wood Edge)

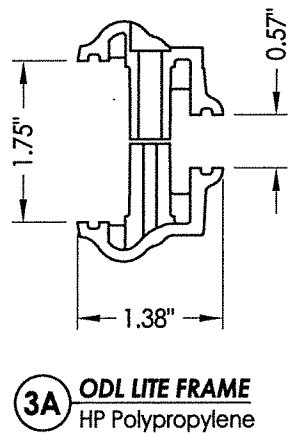
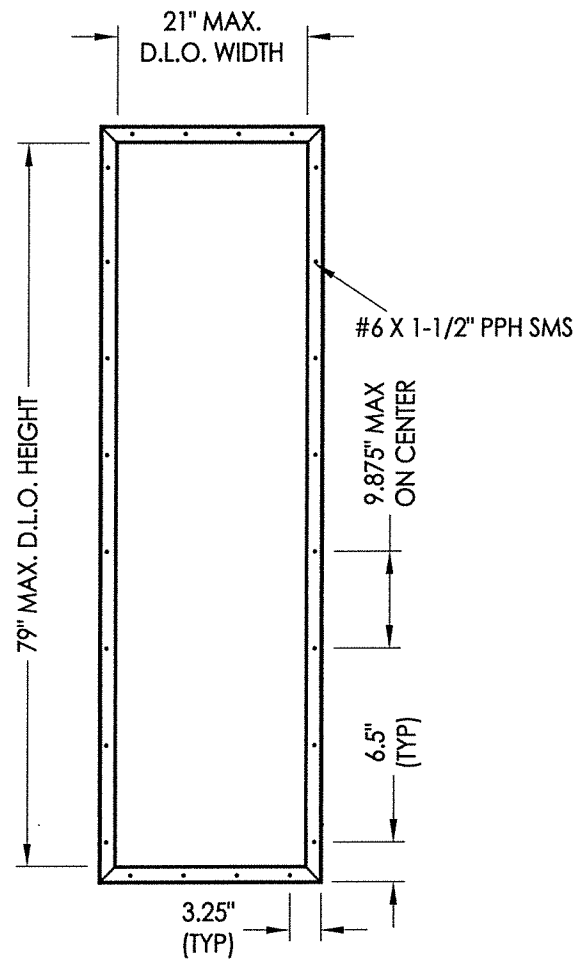

3A OD LITE FRAME
HP Polypropylene

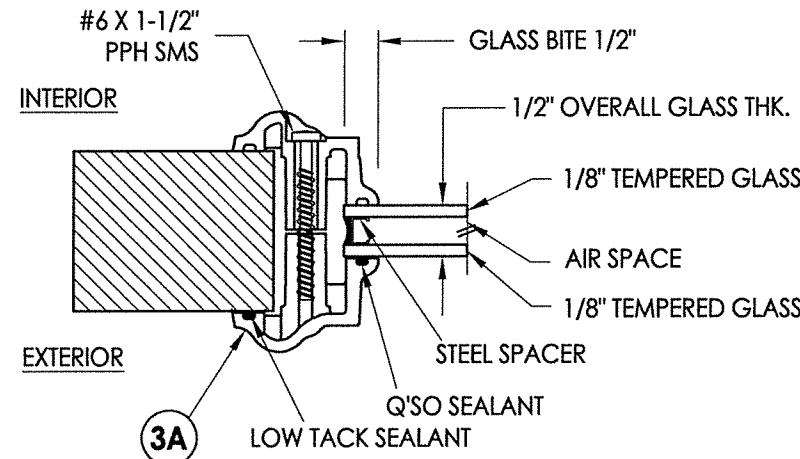

G1 GLAZING DETAIL

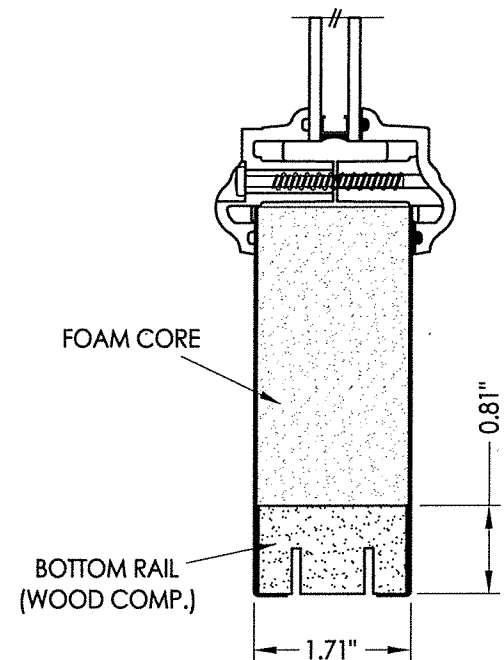
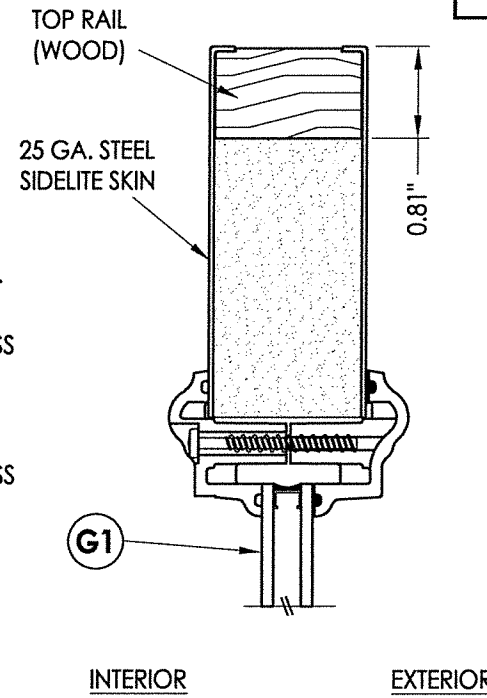

2
3 VERTICAL CROSS SECTION

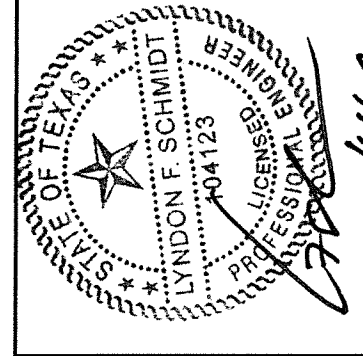

Documents Prepared By: Lyndon F. Schmidt, P.E.
TEXAS P.E. #104123

RW BUILDING CONSULTANTS, INC.
P.O. Box 230 Valrico FL 33595
Phone No.: 813.659.9197
TEXAS BOARD OF PROFESSIONAL ENGINEERS
CERTIFICATE OF REGISTRATION # F-11852

PRODUCT:	ENDURA	
PART OR ASSEMBLY:	SIDELITE PANEL DETAILS (LIP LITE INSERT GLAZING)	
NO.	DATE	BY
1	10/23/19	LFS
ADD: "FusionFrame" OPTION & UPDATE TO 2018 IBC/IRC CODE		
REVISIONS		
DATE:	11/16/16	
SCALE:	N.T.S.	
DWG. BY:	JK	
CHK. BY:	LFS	
DRAWING NO.:	TX-4687	
SHEET	3	OF 7

R:\Clients\Endura PERMANENT\B - Texas Dept of Ins\TDI - DR-864 Masonite ST Glazed (Trilemmium)\C - Drawings\TX-4684.85.87.88.dwg, 4.4

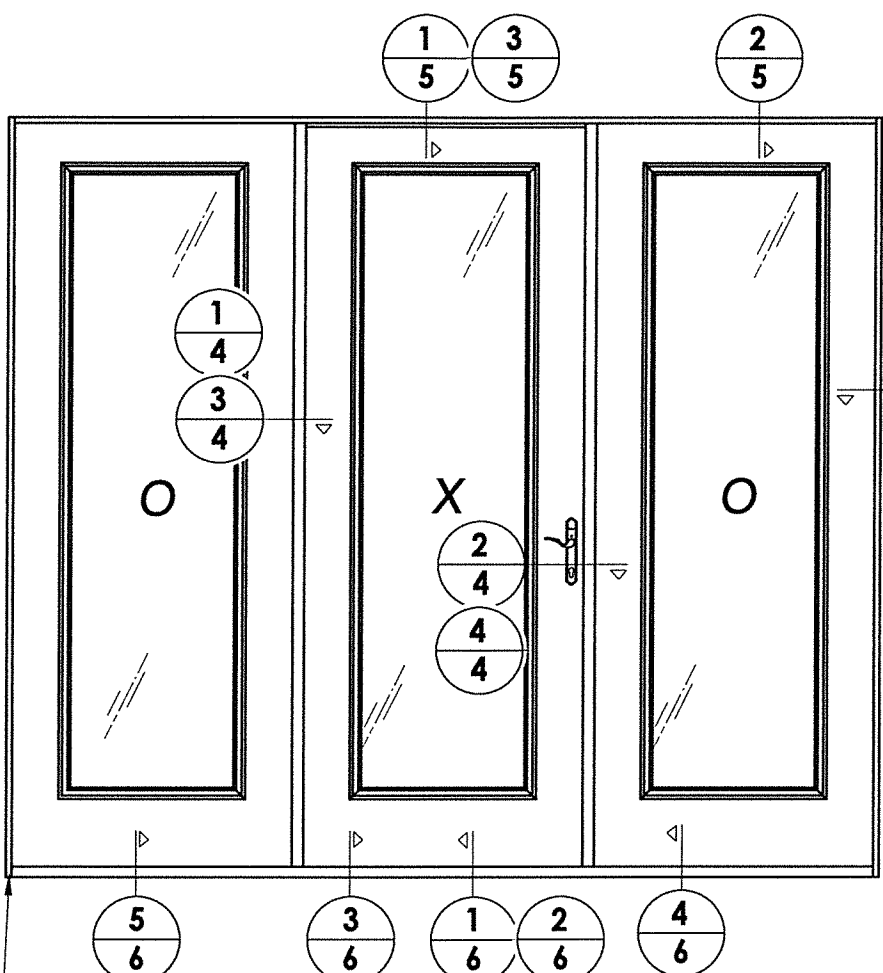

CORNER PADS (TYP.)

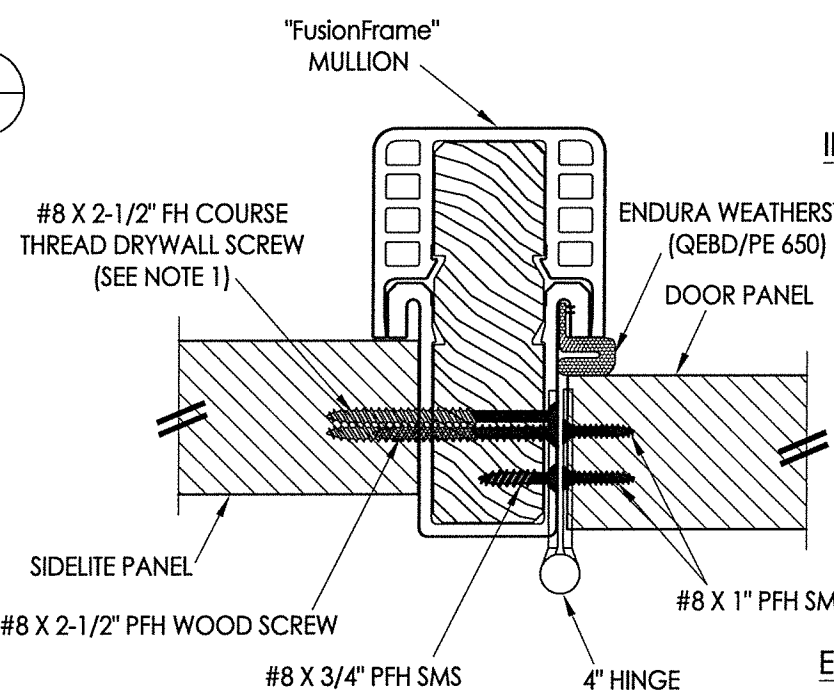
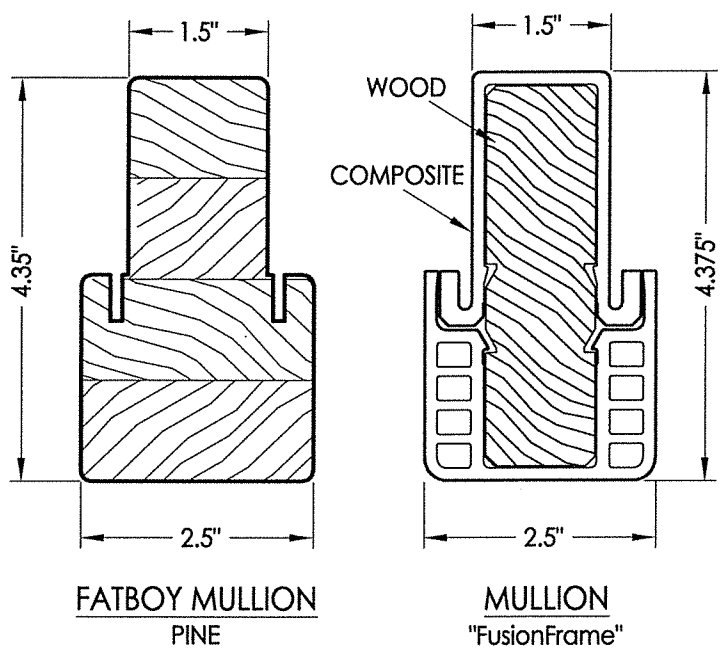

3 HORIZONTAL CROSS SECTION
4 Outswing shown - Inswing also approved

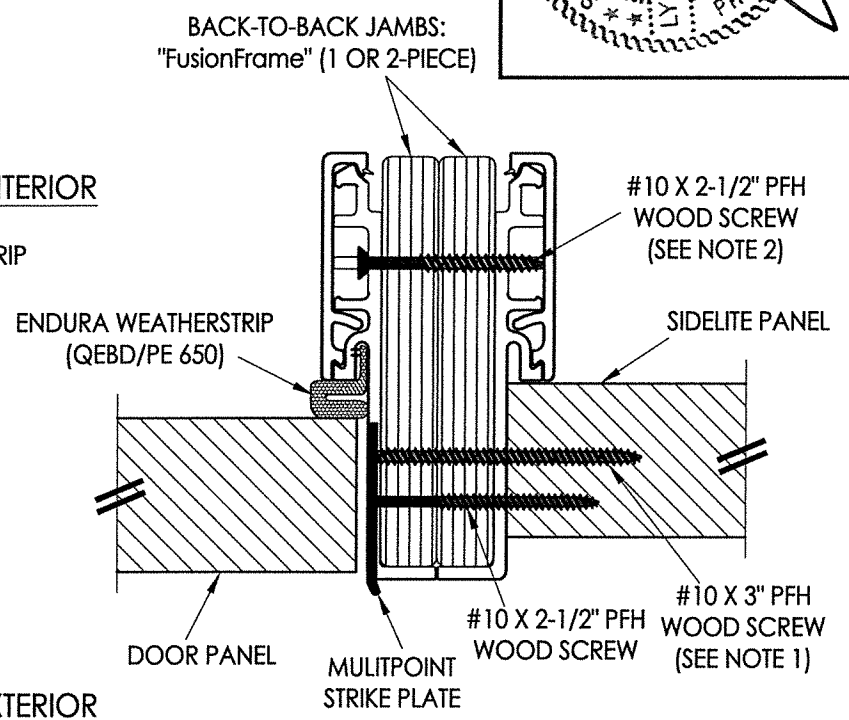

4 HORIZONTAL CROSS SECTION
4 Outswing shown - Inswing also approved

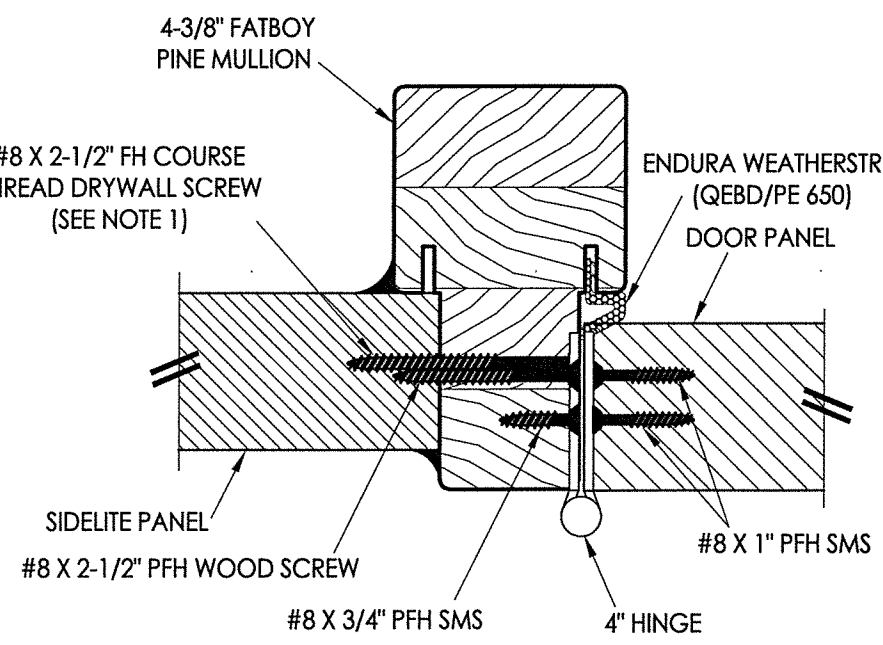

1 HORIZONTAL CROSS SECTION
4 Outswing shown - Inswing also approved

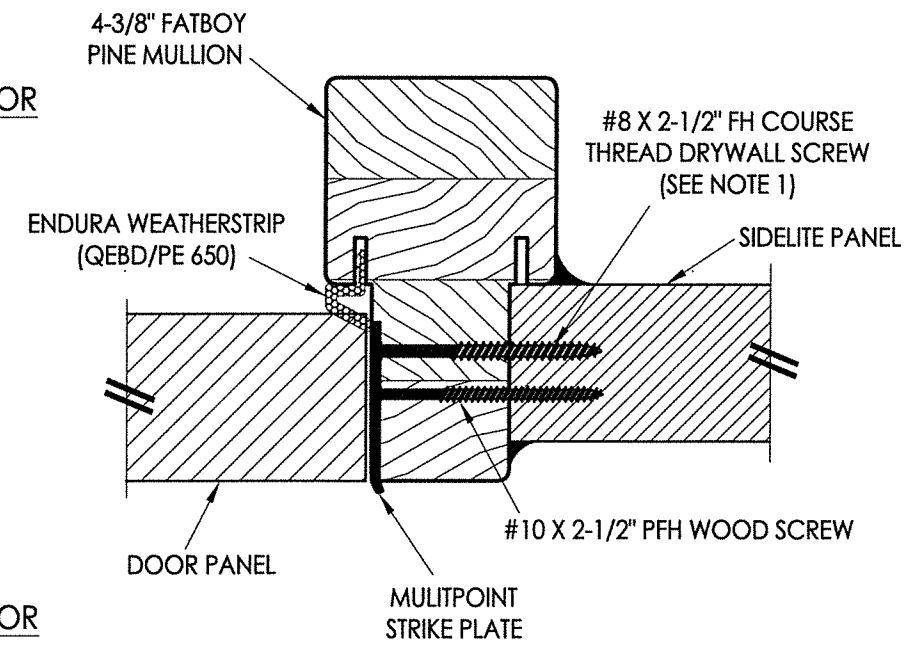

2 HORIZONTAL CROSS SECTION
4 Outswing shown - Inswing also approved

NOTES:
1. Spacing for sidelite screws: 6.5", 35.5", 57.25" and 85" from head to sill (4 total).
2. Spacing for mullion screws: 6" from each end plus 3 more equally spaced (5 total).

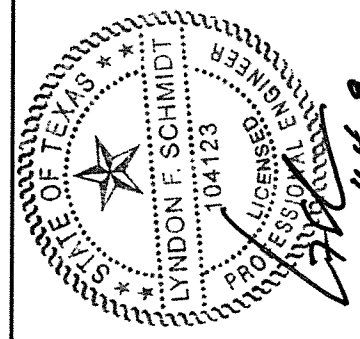

Documents Prepared By: Lyndon F. Schmidt, P.E.
TEXAS P.E. #104123

RW BUILDING CONSULTANTS, INC.
P.O. Box 230 Valrico FL 33595
Phone No.: 813.659.9197

TEXAS BOARD OF PROFESSIONAL ENGINEERS
CERTIFICATE OF REGISTRATION # F-11852

PRODUCT:	ENDURA	
	Steel DOOR	
PART OR ASSEMBLY:	HORIZONTAL CROSS SECTIONS	
NO.	DATE	BY
1	10/23/19	LFS
ADD "FusionFrame" OPTION & UPDATE TO 2018 IBC/IRC CODE		
REVISIONS		
DATE:	11/16/16	
SCALE:	N.T.S.	
DWG. BY:	JK	
CHK. BY:	LFS	
DRAWING NO.:	TX-4687	
SHEET	4	OF 7

© 2016 R.W. BUILDING CONSULTANTS INC.

R:\Clients\Endura PERMANENT\B - Texas Dept of Ins\TDI - DR-864 Masonite ST Glazed (Trilennium)\C - Drawings\TX-4684.85.87.88.dwg, 5.4

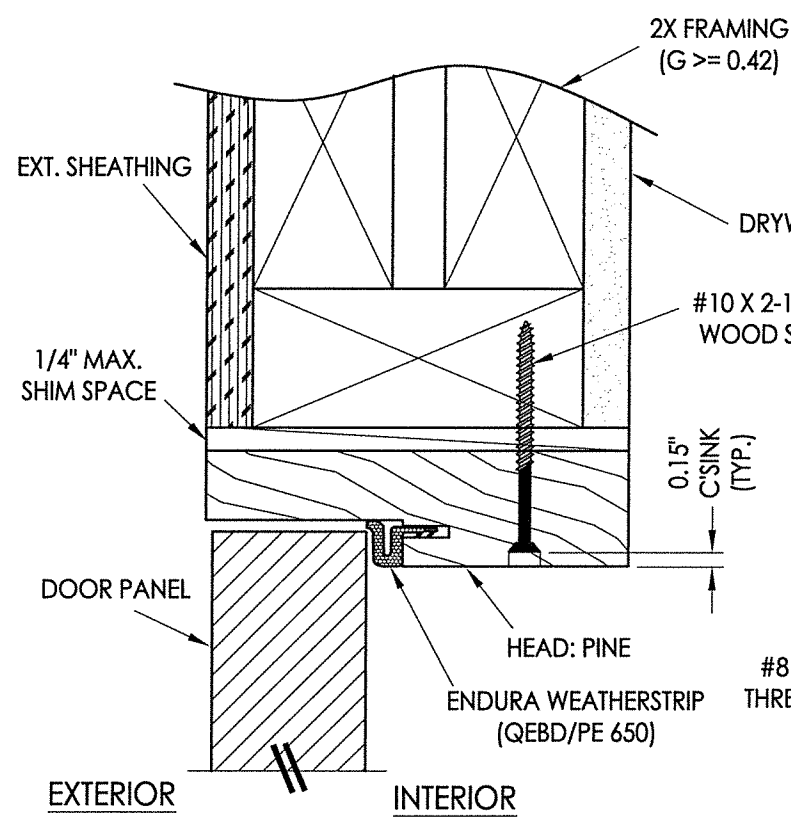

1 VERTICAL CROSS SECTION
5 Outswing shown - inswing also approved

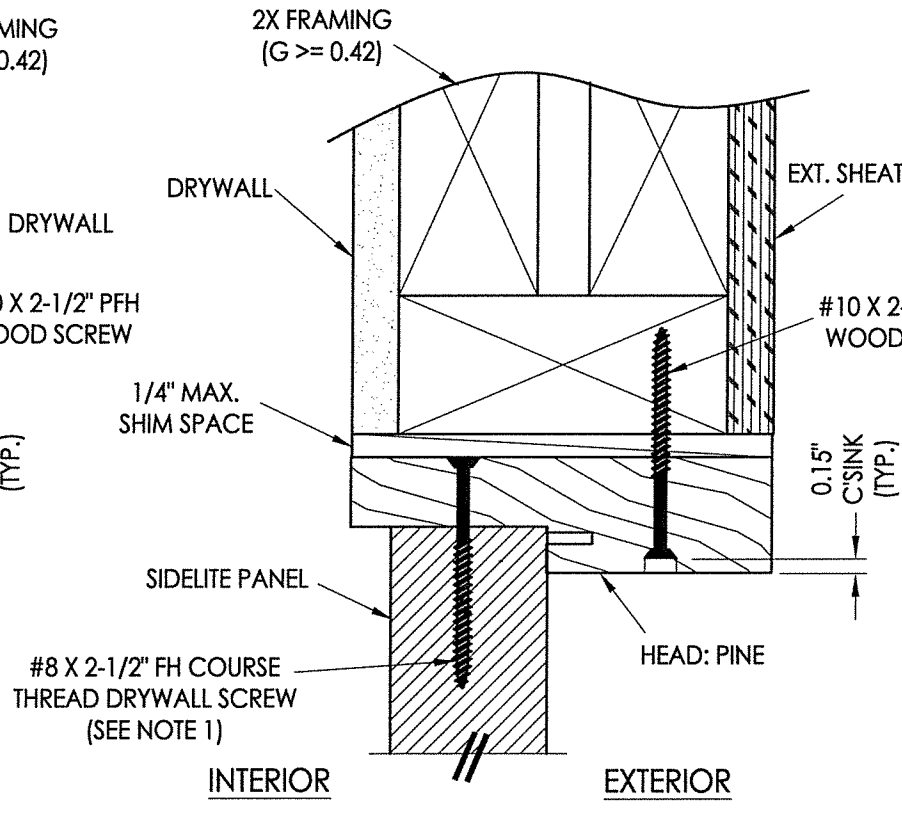

2 VERTICAL CROSS SECTION
5 Inswing shown - Outswing also approved

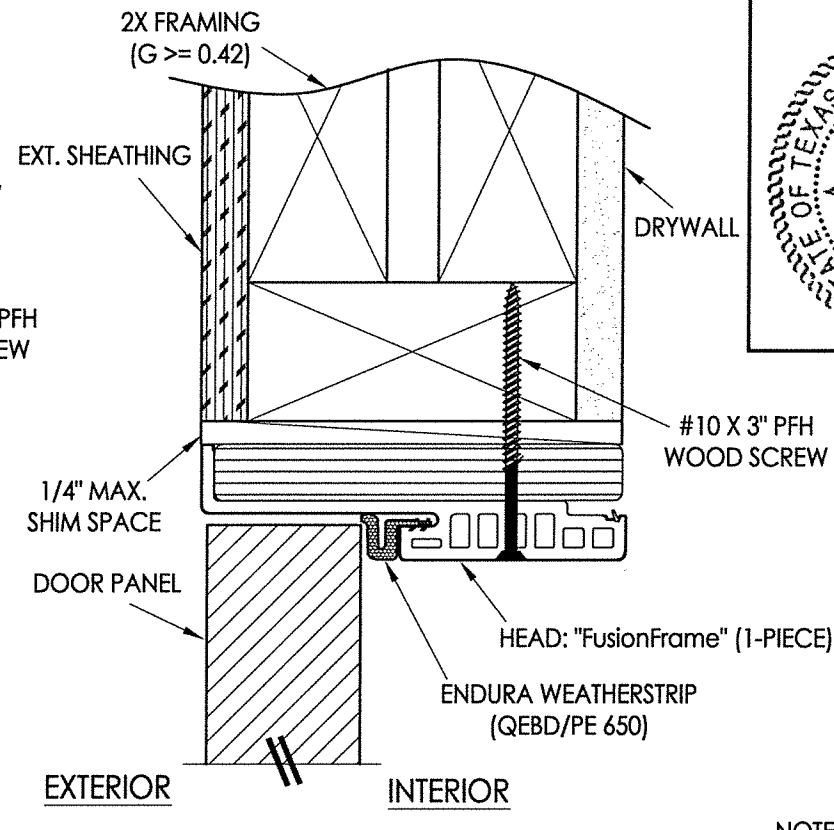

3 VERTICAL CROSS SECTION
5 Outswing shown - inswing also approved

NOTE:
1. Spacing for sidelite screws:
6" from each end (2 total).

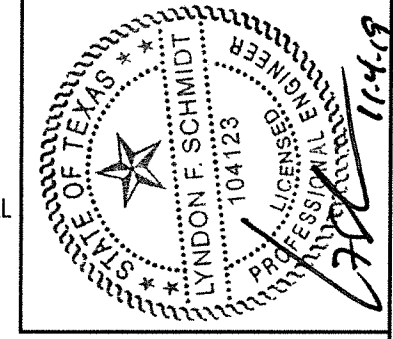

Documents Prepared By: Lyndon F. Schmidt, P.E.
TEXAS P.E. #104123

RW BUILDING CONSULTANTS, INC.
P.O. Box 230 Valrico FL, 33595
Phone No.: 813.659.9197
TEXAS BOARD OF PROFESSIONAL ENGINEERS
CERTIFICATE OF REGISTRATION # F-11852

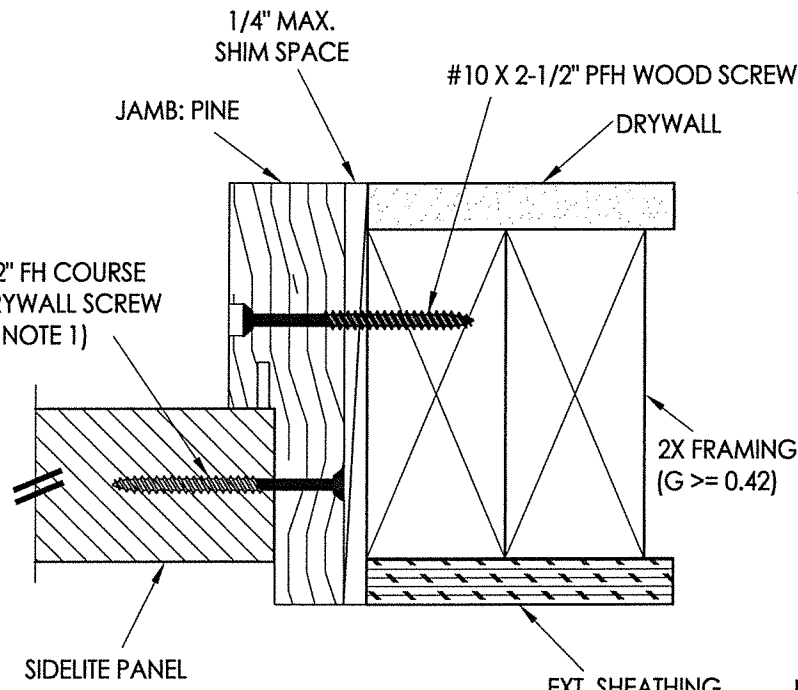
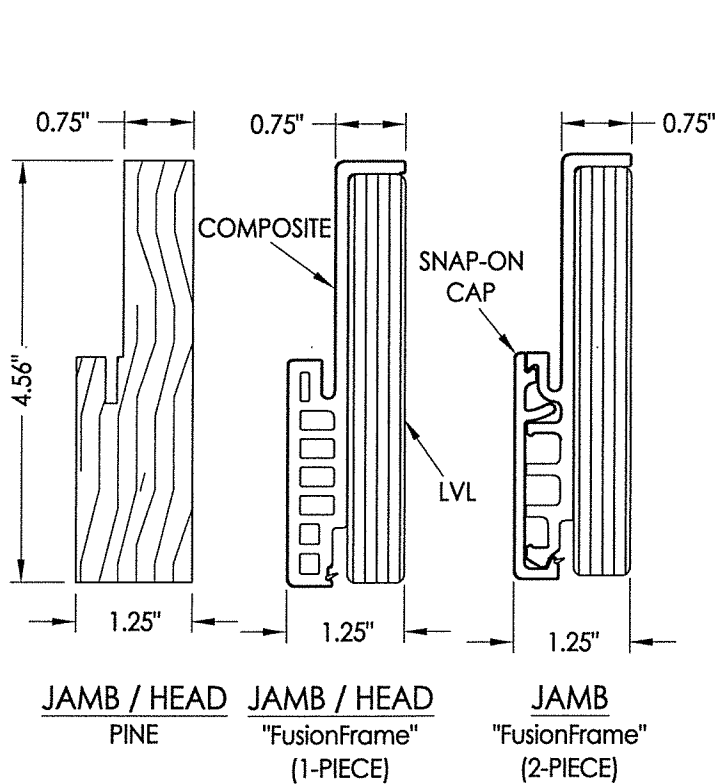

4 HORIZONTAL CROSS SECTION
5 Outswing shown - Inswing also approved

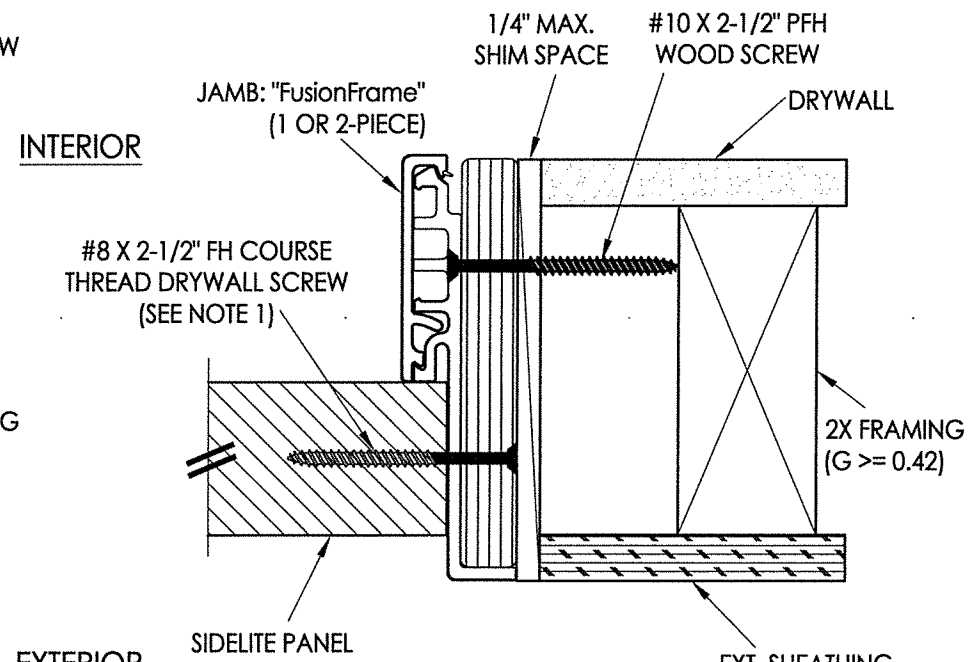

5 HORIZONTAL CROSS SECTION
5 Outswing shown - Inswing also approved

PRODUCT: ENDURA

PART OR ASSEMBLY: VERTICAL CROSS SECTIONS

NO.	DATE	REVISIONS
1	10/23/19	ADD "FusionFrame" OPTION & UPDATE TO 2018 IBC/IRC CODE

DATE:	11/16/16
SCALE:	N.T.S.
DWG. BY:	JK
CHK. BY:	LFS
DRAWING NO.:	TX-4687
SHEET	5 OF 7

© 2016 R.W. BUILDING CONSULTANTS INC.

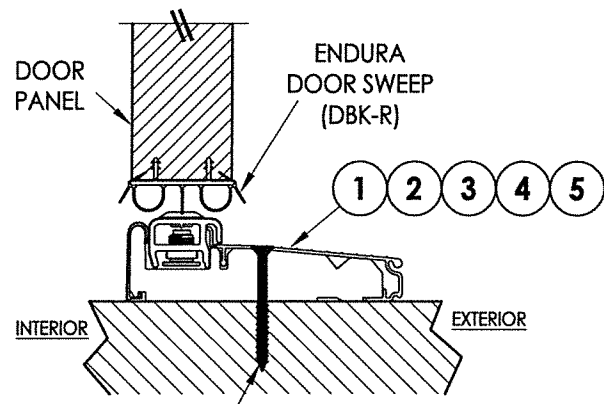

#10 X 2.5" PFH WOOD SCREW OR
1/4" X 2-3/4" ELCO OR ITW CONCRETE SCREW

1 VERTICAL CROSS SECTION
6 Inswing Adjustable Threshold

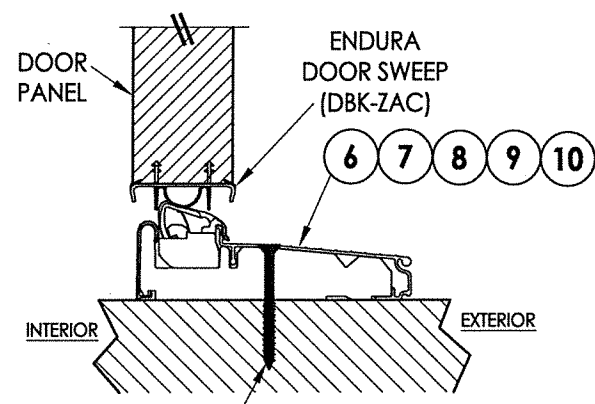

#10 X 2.5" PFH WOOD SCREW OR
1/4" X 2-3/4" ELCO OR ITW CONCRETE SCREW

2 VERTICAL CROSS SECTION
6 Inswing Articulating Threshold

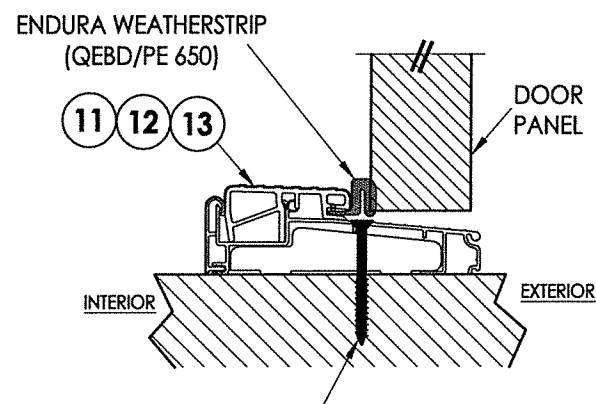

#10 X 2.5" PFH WOOD SCREW OR
1/4" X 2-3/4" ELCO OR ITW CONCRETE SCREW

3 VERTICAL CROSS SECTION
6 Outswing Bump Threshold

NOTE:
1. Spacing for sidelite screws:
6" from each end (2 total).

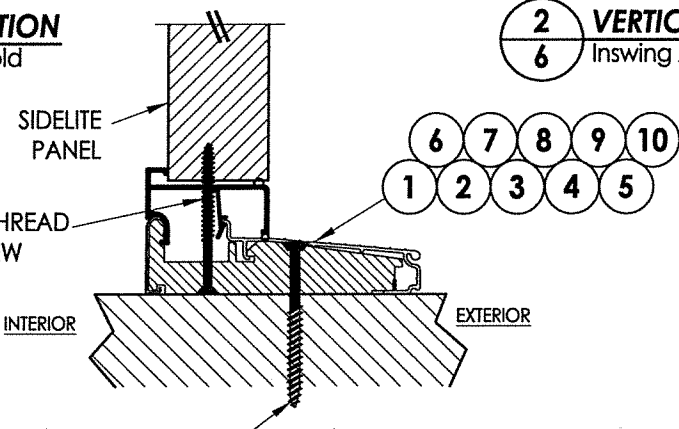

#8 X 2.5" COURSE THREAD
DRYWALL SCREW
(SEE NOTE 1)

#10 X 2.5" PFH WOOD SCREW OR
1/4" X 2-3/4" ELCO OR ITW CONCRETE SCREW

4 VERTICAL CROSS SECTION
6 Inswing configuration

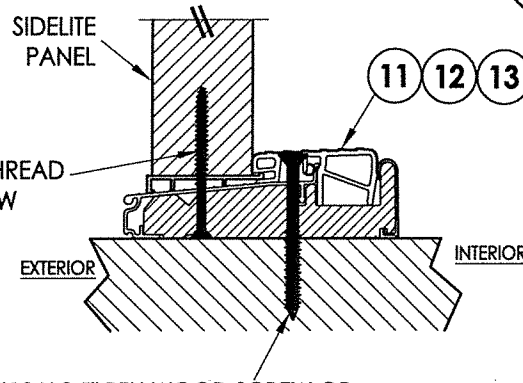

#8 X 2.5" COURSE THREAD
DRYWALL SCREW
(SEE NOTE 1)

#10 X 2.5" PFH WOOD SCREW OR
1/4" X 2-3/4" ELCO OR ITW CONCRETE SCREW

5 VERTICAL CROSS SECTION
6 Outswing configuration

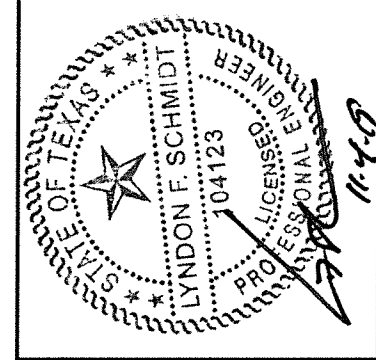

Documents Prepared By: Lyndon F. Schmidt, P.E.
TEXAS P.E. #104123

R.W. BUILDING CONSULTANTS, INC.
P.O. Box 230 Vairico FL 33595
Phone No.: 813.659.9197
TEXAS BOARD OF PROFESSIONAL ENGINEERS
CERTIFICATE OF REGISTRATION # F-11852

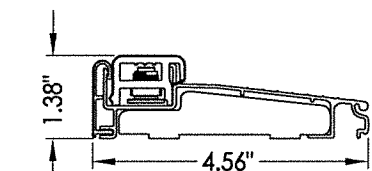

1 INSWING ADJUSTABLE THRESHOLD
ZAI4565

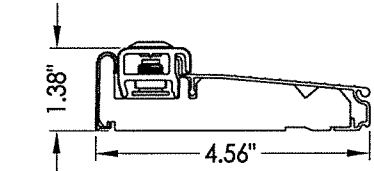

2 INSWING ADJUSTABLE THRESHOLD
ZAI4565FN

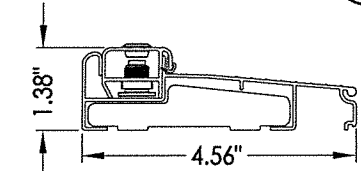

3 INSWING ADJUSTABLE THRESHOLD
ZAI4565

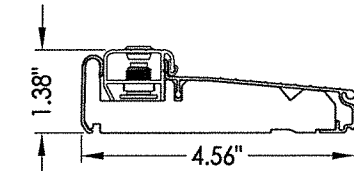

4 INSWING ADJUSTABLE THRESHOLD
ZAI4565FN

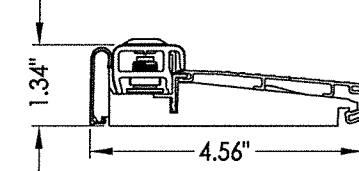

5 INSWING ADJUSTABLE THRESHOLD
ZAI4565RDS

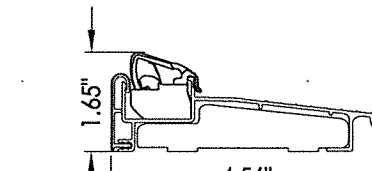

6 INSWING ARTICULATING THRESHOLD
ZACL4565

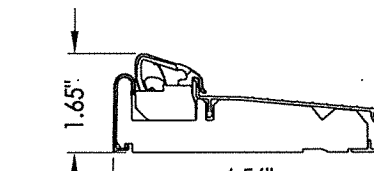

7 INSWING ARTICULATING THRESHOLD
ZAC4565FN

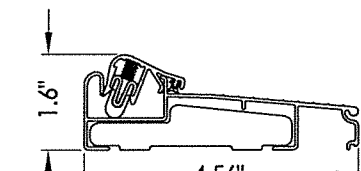

8 INSWING ARTICULATING THRESHOLD
ZAC4565

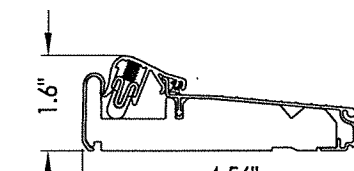

9 INSWING ARTICULATING THRESHOLD
ZAC4565FN

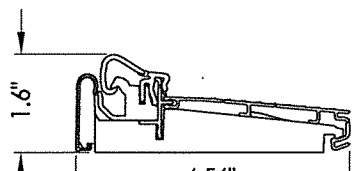

10 INSWING ARTICULATING THRESHOLD
ZAC4565RDS

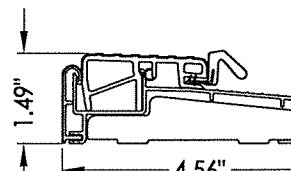

11 OUTSWING THRESHOLD
ZOB4565

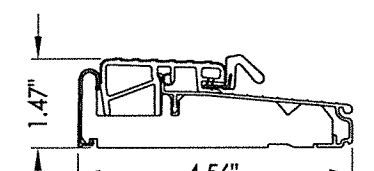

12 OUTSWING THRESHOLD
ZOB4565FN

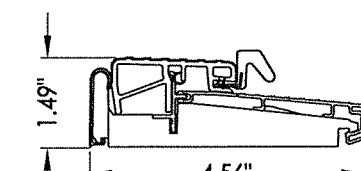

13 OUTSWING THRESHOLD
ZOB4565RDS

PRODUCT: ENDURA
PART OR ASSEMBLY: VERTICAL CROSS SECTIONS

NO.	DATE	BY	REVISIONS
1	10/23/19	LFS	ADD "FusionFrame" OPTION & UPDATE TO 2018 IBC/IRC CODE

DATE: 11/16/16
SCALE: N.T.S.
DWG. BY: JK
CHK. BY: LFS
DRAWING NO.: TX-4687
SHEET 6 OF 7

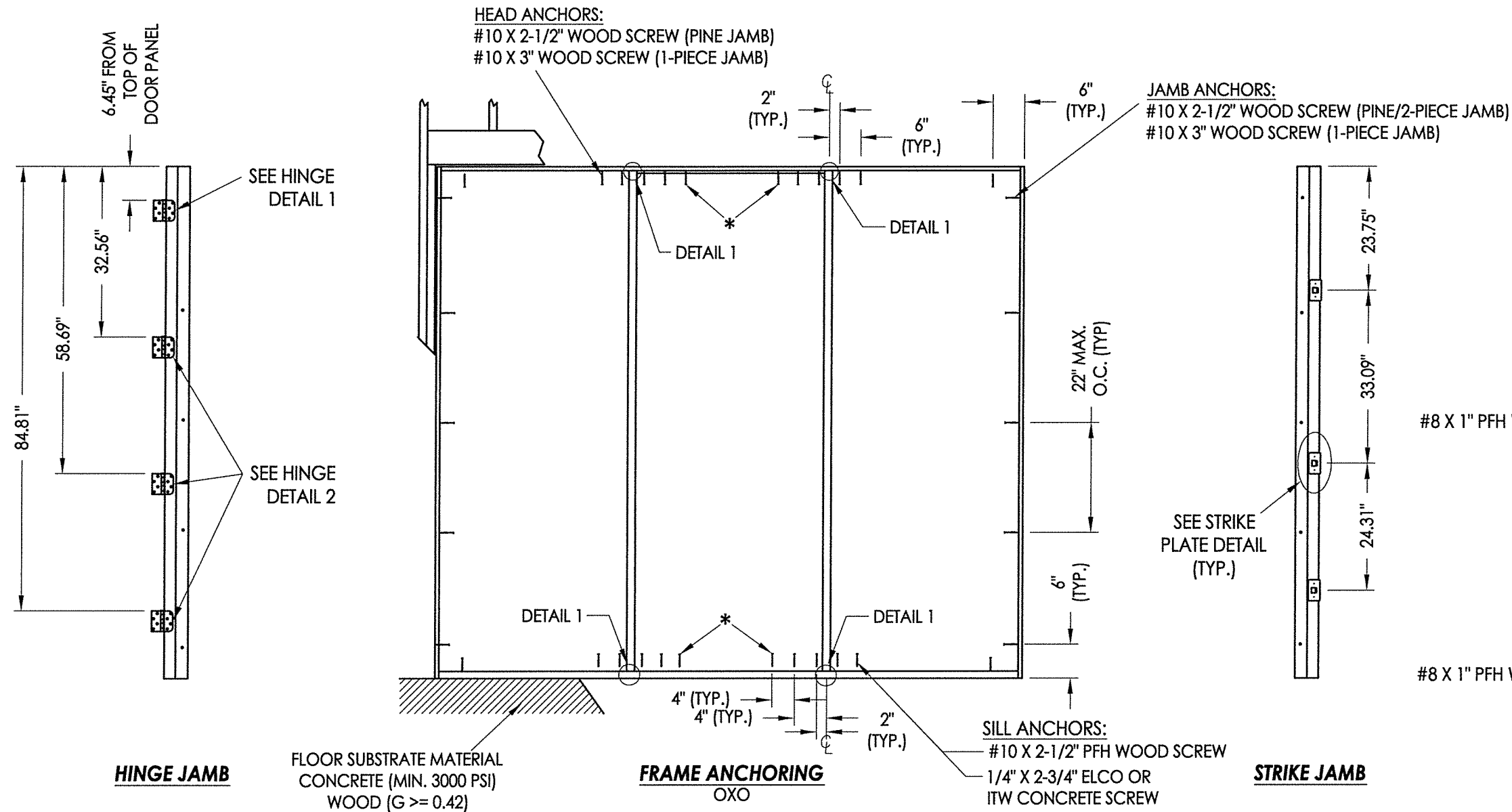

FLOOR SUBSTRATE MATERIAL
 CONCRETE (MIN. 3000 PSI)
 WOOD (G >= 0.42)

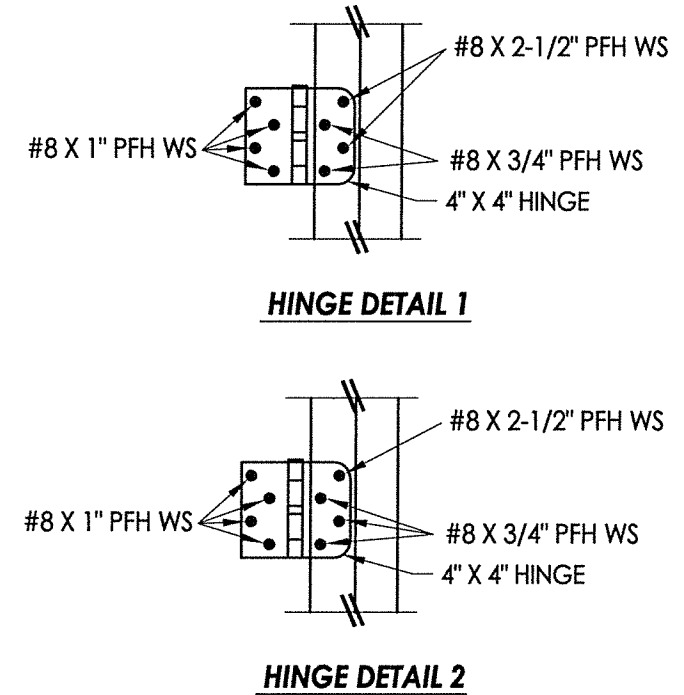

JAMB NOTES:
 THE PINE OR "FusionFrame" 1-PIECE JAMB MAY BE INSTALLED @ THE HEAD OR SIDE JAMB.
 THE FusionFrame" 2-PIECE JAMB MAY BE INSTALLED @ THE SIDE JAMBS ONLY.

INTEGRAL MULLION NOTES:
 THE FATBOY PINE MULLION, "FusionFrame" MULLION, OR THE "FusionFrame" BACK-TO-BACK JAMB (1-PIECE OR 2-PIECE) MAY ALL BE USED AS THE INTEGRAL MULLION.

- CONCRETE ANCHOR NOTES:**
- Concrete anchor locations at the corners may be adjusted to maintain the min. edge distance to mortar joints.
 - Concrete anchor locations noted as "MAX. ON CENTER" must be adjusted to maintain the min. edge distance to mortar joints, additional concrete anchors may be required to ensure the "MAX. ON CENTER" dimension are not exceeded.
 - Concrete anchor table:

ANCHOR TYPE	ANCHOR SIZE	MIN. EMBEDMENT	MIN. CLEARANCE TO MASONRY EDGE	MIN. CLEARANCE TO ADJACENT ANCHOR
ITW TAPCON®	1/4"	1-3/4"	1-1/2"	4"
ELCO ULTRACON®	1/4"	1-3/4"	1"	4"

* NOTE: These anchors are required for D.P. > 40 PSF.

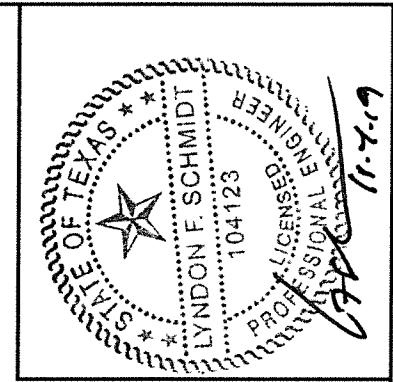
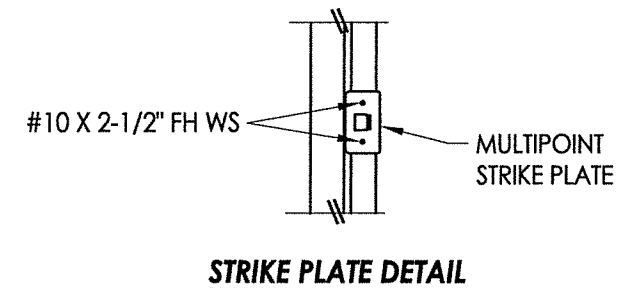
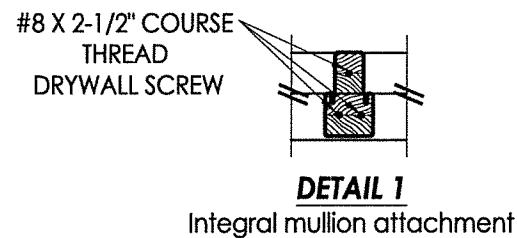

Documents Prepared By: Lyndon F. Schmidt, P.E.
 TEXAS P.E. #104123

RW BUILDING CONSULTANTS, INC.
 P.O. Box 230 Valrico FL 33595
 Phone No.: 813.659.9197

TEXAS BOARD OF PROFESSIONAL ENGINEERS
 CERTIFICATE OF REGISTRATION # F-11852

PRODUCT:	ENDURA
PART OR ASSEMBLY:	FRAME ANCHORING
NO.	DATE
BY	REVISIONS
1	10/23/19 ADD "FusionFrame" OPTION & UPDATE TO 2018 IBC/IRC CODE

DATE: 11/16/16
 SCALE: N.T.S.
 DWG. BY: JK
 CHK. BY: LFS
 DRAWING NO.: TX-4687
 SHEET 7 OF 7