



Opaque Steel Door

"NON-IMPACT"
INSWING / OUTSWING

EVALUATED FOR USE IN THE STATE OF TEXAS

The Steel Door system described herein complies with the 2018 International Residential Code (IRC), Sections R301 & R609 and the 2018 International Building Code (IBC), Sections 1404.13, 1609, 1709.5, 2403 and 2404 subject to the following conditions:

1. Anchors shall be as listed and spaced as shown in the details. Anchor embedment to base material shall be beyond wall dressing or stucco.
2. When used in areas requiring wind-borne debris protection this product is required to be protected with an impact resistant covering that complies with Section R301.2.1.2 of the IRC and Section 1609.2 of the IBC.
3. Allowable design pressure requirements must be equal to or less than the design pressure rating shown in the design pressure chart, sheet 1 of this drawing.
4. Conditions not covered by this drawing are subject to further engineering analysis.

TABLE OF CONTENTS	
SHEET #	DESCRIPTION
1	Typical elevations, design pressures & general notes
2	Astragal details (Ultimate Trilennium)
3	Door panel details
4	Horizontal & vertical cross sections
5	Vertical cross sections
6	Frame anchoring

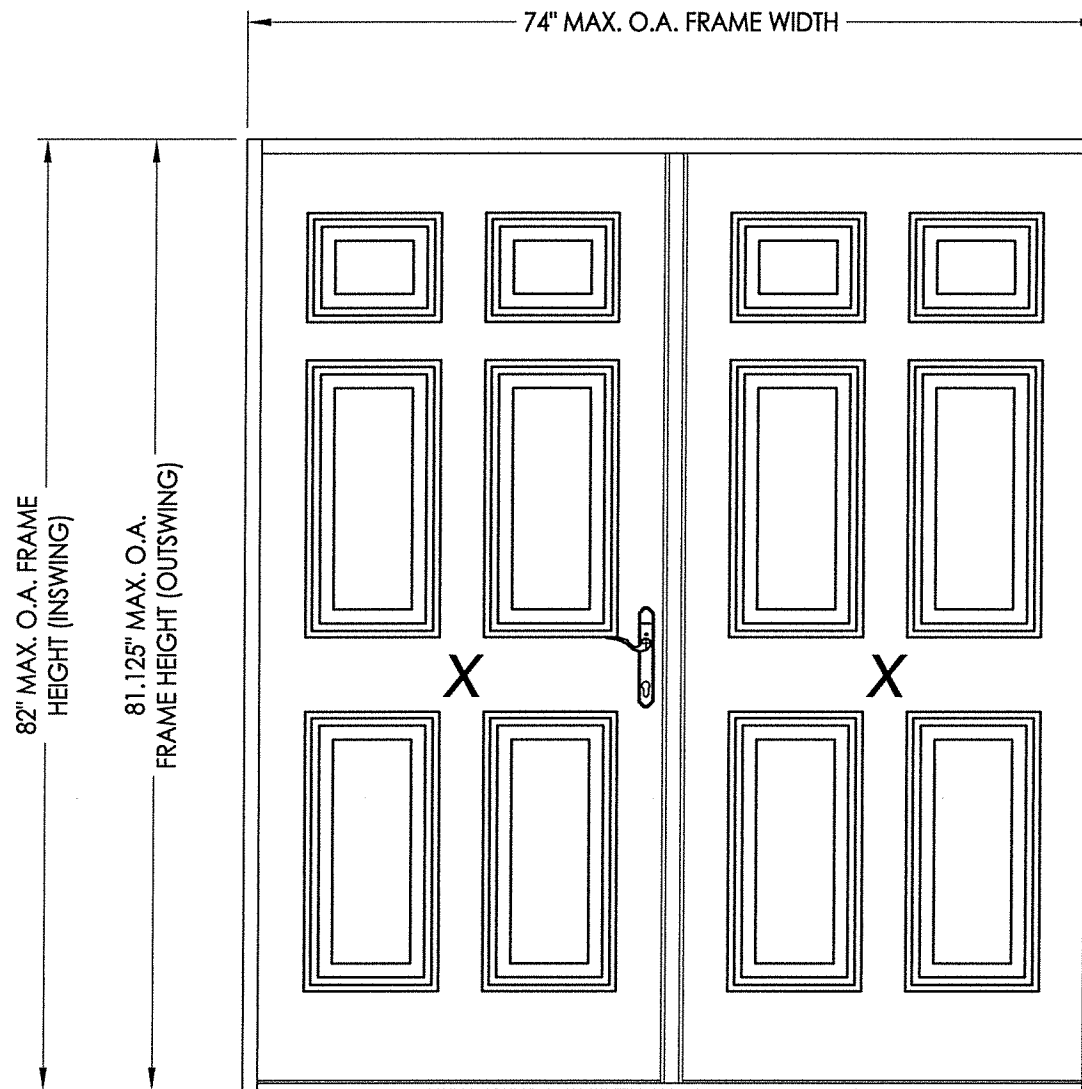

CONFIG.	MODEL	DESIGN PRESSURE (PSF) ULTIMATE TRILENNIUM ASTRAGAL	
		POSITIVE	NEGATIVE
XX	INSWING	+40.0	-40.0
XX	OUTSWING	+45.0	-45.0

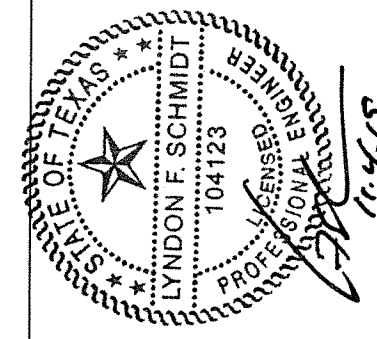

Documents Prepared By: Lyndon F. Schmidt, P.E.
TEXAS P.E. #104123

RW BUILDING CONSULTANTS, INC.
P.O. Box 230 Valrico FL 33595
Phone No.: 813.659.9197

TEXAS BOARD OF PROFESSIONAL ENGINEERS
CERTIFICATE OF REGISTRATION # F-11852

PRODUCT: ENDURA

PART OR ASSEMBLY: TYPICAL ELEVATION, DESIGN PRESSURES & GENERAL NOTES

NO.	DATE	BY	REVISIONS
1	11/4/19	LFS	ADD "FusionFrame" OPTION & UPDATE TO 2018 IBC/IRC CODE

DATE: 11/16/16

SCALE: N.T.S.

DWG. BY: JK

CHK. BY: LFS

DRAWING NO.: TX-4679

SHEET 1 OF 6

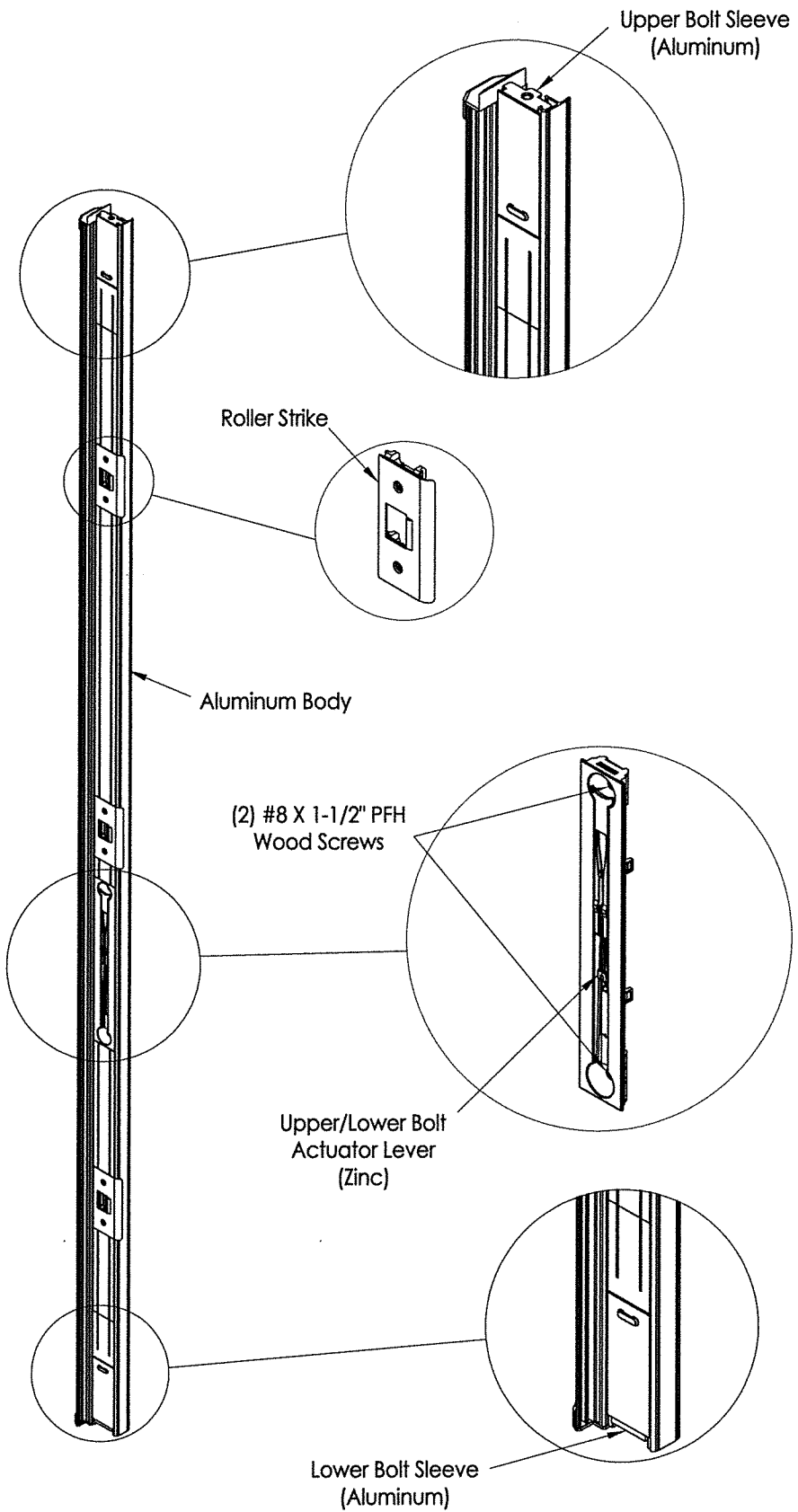

ULTIMATE TRIENNIMUM ASTRAGAL

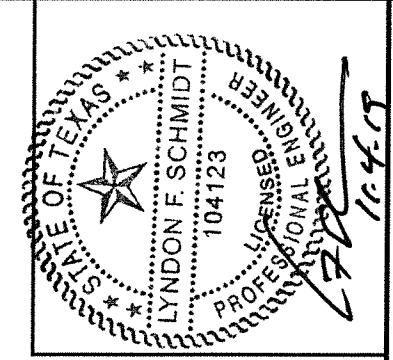
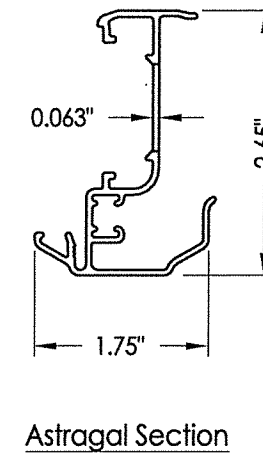
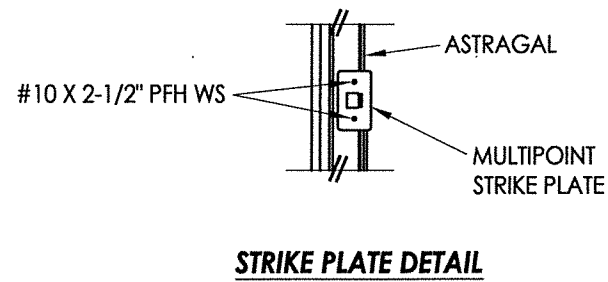
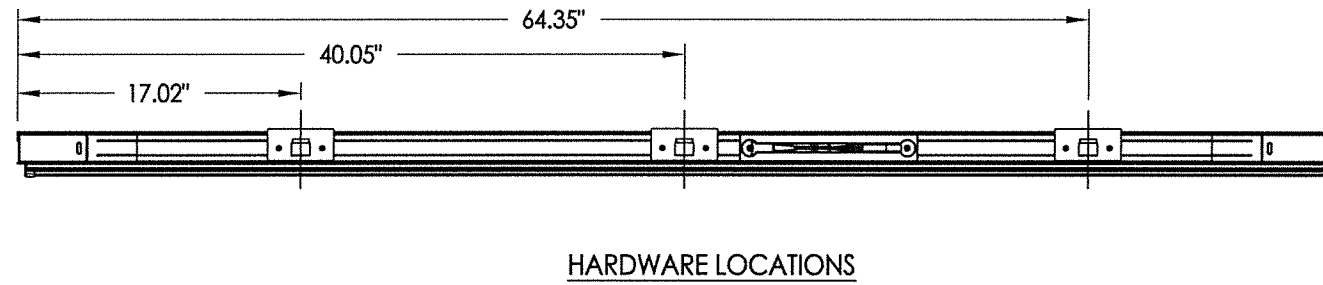
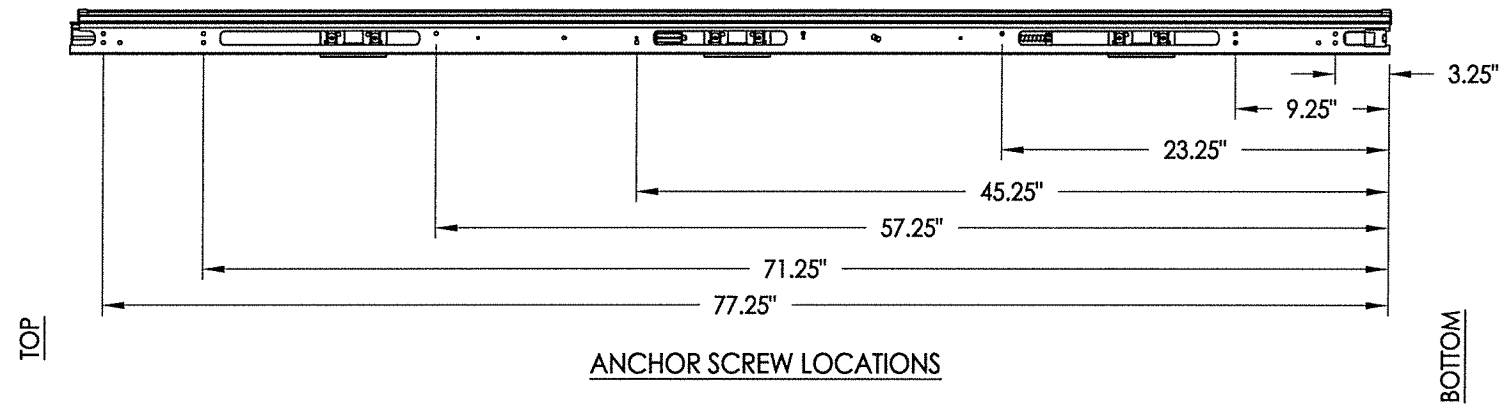

Documents Prepared By: Lyndon F. Schmidt, P.E.
TEXAS P.E. #104123

RW BUILDING CONSULTANTS, INC.
P.O. Box 230 Vairico FL 33595
Phone No.: 813.659.9197

TEXAS BOARD OF PROFESSIONAL ENGINEERS
CERTIFICATE OF REGISTRATION # F-11852

PRODUCT:	ENDURA	
PART OR ASSEMBLY:	ASTRAGAL DETAILS (ULTIMATE TRIENNIMUM)	
NO.	DATE	BY
1	11/4/19	LFS
ADD "FusionFrame" OPTION & UPDATE TO 2018 IBC/IRC CODE		
REVISIONS		
DATE:	11/16/16	
SCALE:	N.T.S.	
DWG. BY:	JK	
CHK. BY:	LFS	
DRAWING NO.:	TX-4679	
SHEET	2 OF 6	

R:\Clients\Endura PERMANENT\B - Texas Dept of Ins\TDI - DR-854 Masonite ST Opaque (Trilennium)\C - Drawings\TX-4678-79.81.82.dwg, 1.3

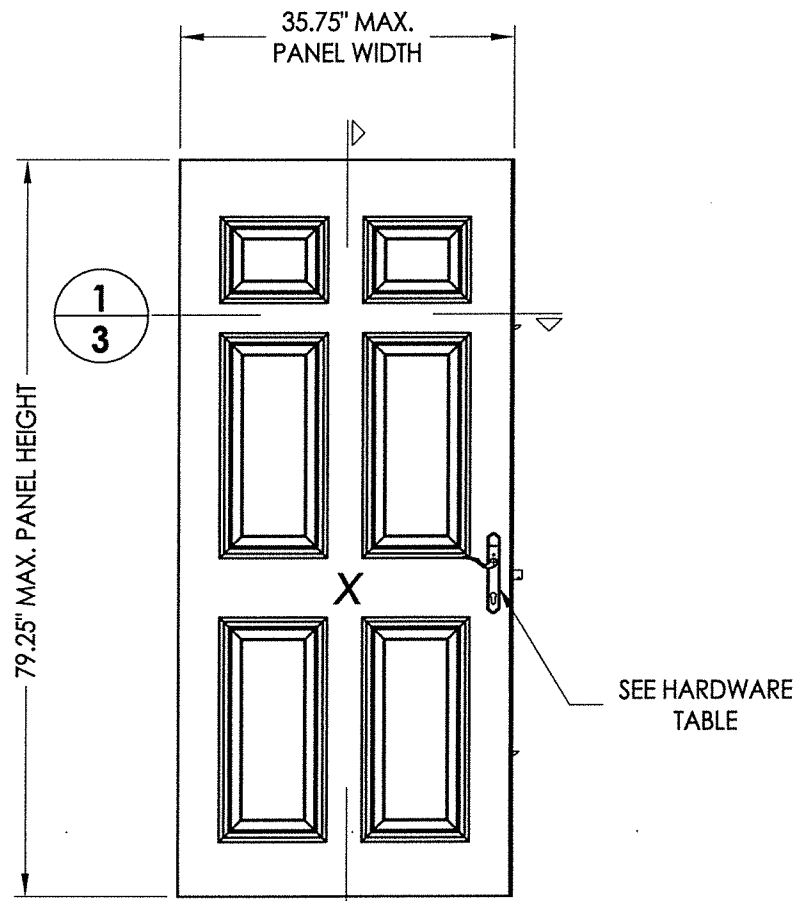

DOOR PANEL
Masonite
Steel (Wood Edge)

DOOR SKIN: 25 GA. STEEL (0.020" MIN. THICKNESS)
CORE MATERIAL: POLYURETHANE FOAM (1.9 PCF MIN.)

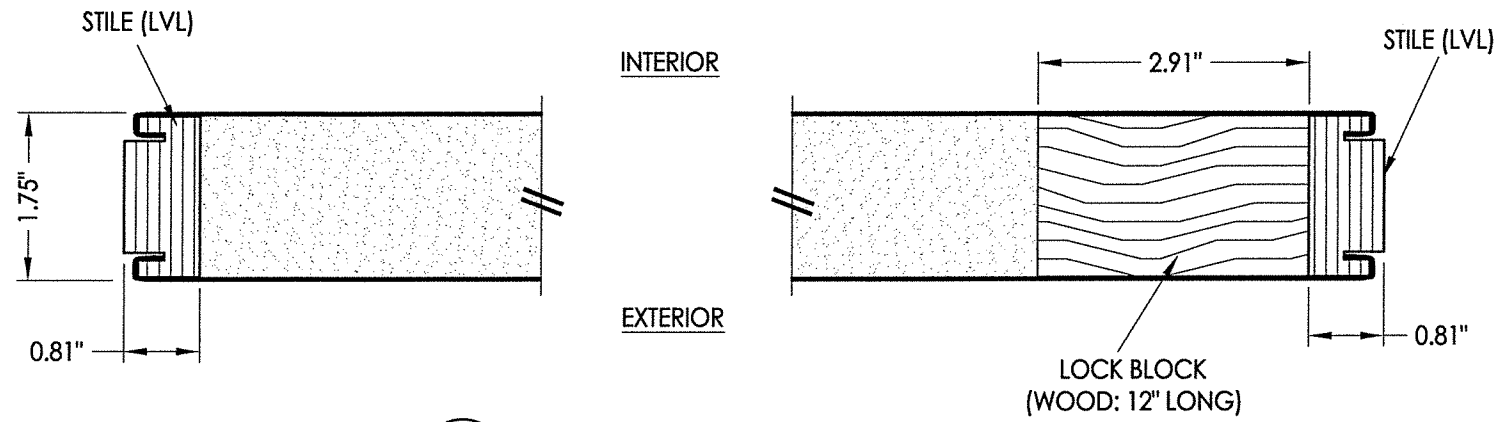

1
3 HORIZONTAL CROSS SECTION

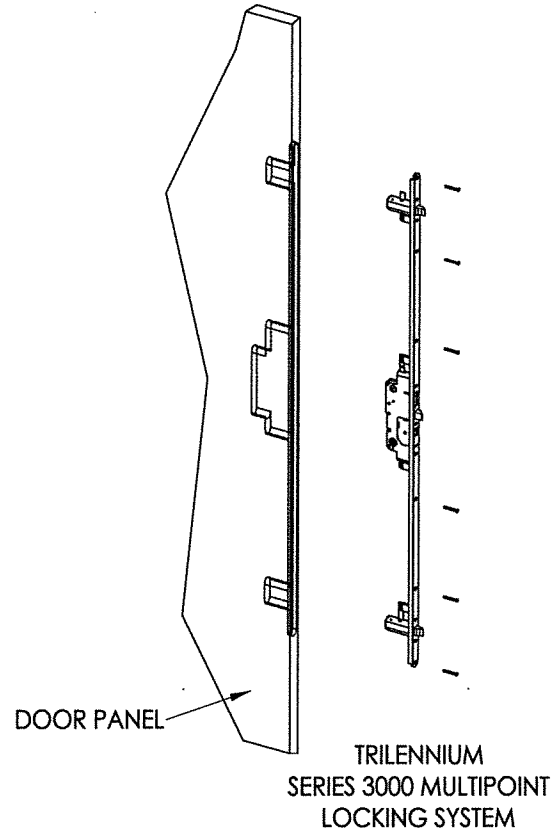

HARDWARE TABLE	
MANUFACTURER	MODEL
Endura	Trilennium® 3000 Series Multipoint lock (3pt.)

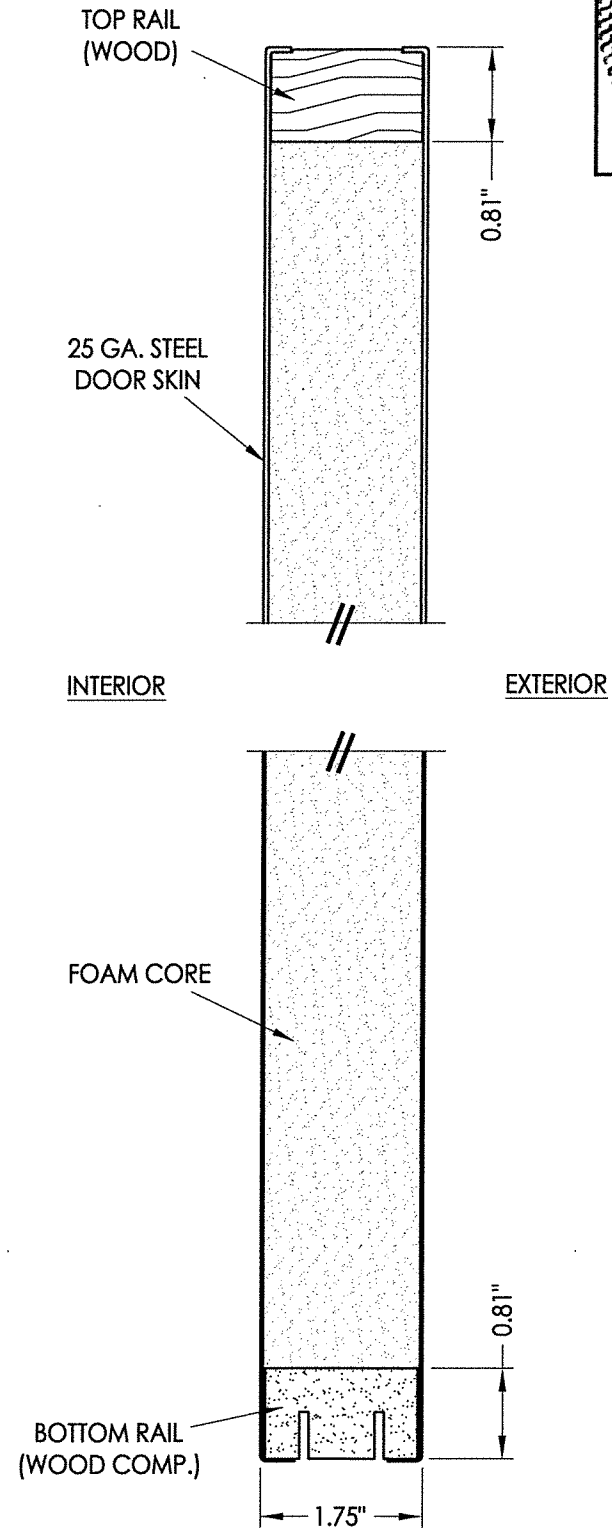

2
3 VERTICAL CROSS SECTION

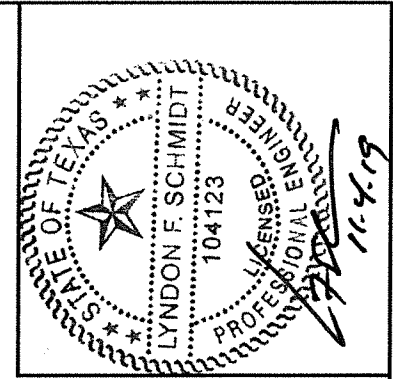

Documents Prepared By: Lyndon F. Schmidt, P.E.
TEXAS P.E. #104123

RW BUILDING CONSULTANTS, INC.
P.O. Box 230 Valrico FL 33595
Phone No.: 813.659.9197
TEXAS BOARD OF PROFESSIONAL ENGINEERS
CERTIFICATE OF REGISTRATION # F-11852

PRODUCT: ENDURA
PART OR ASSEMBLY: DOOR PANEL DETAILS & GLAZING DETAIL

NO.	DATE	REVISIONS	BY
1	11/4/19	ADD "FusionFrame" OPTION & UPDATE TO 2018 IBC/IRC CODE	LFS

DATE: 11/16/16
SCALE: N.T.S.
DWG. BY: JK
CHK. BY: LFS
DRAWING NO.: TX-4679
SHEET 3 OF 6

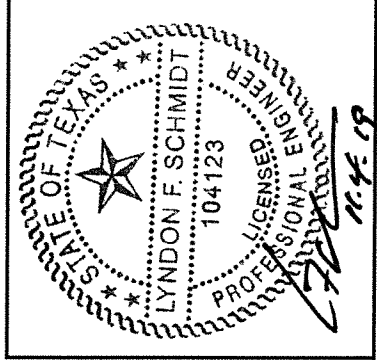
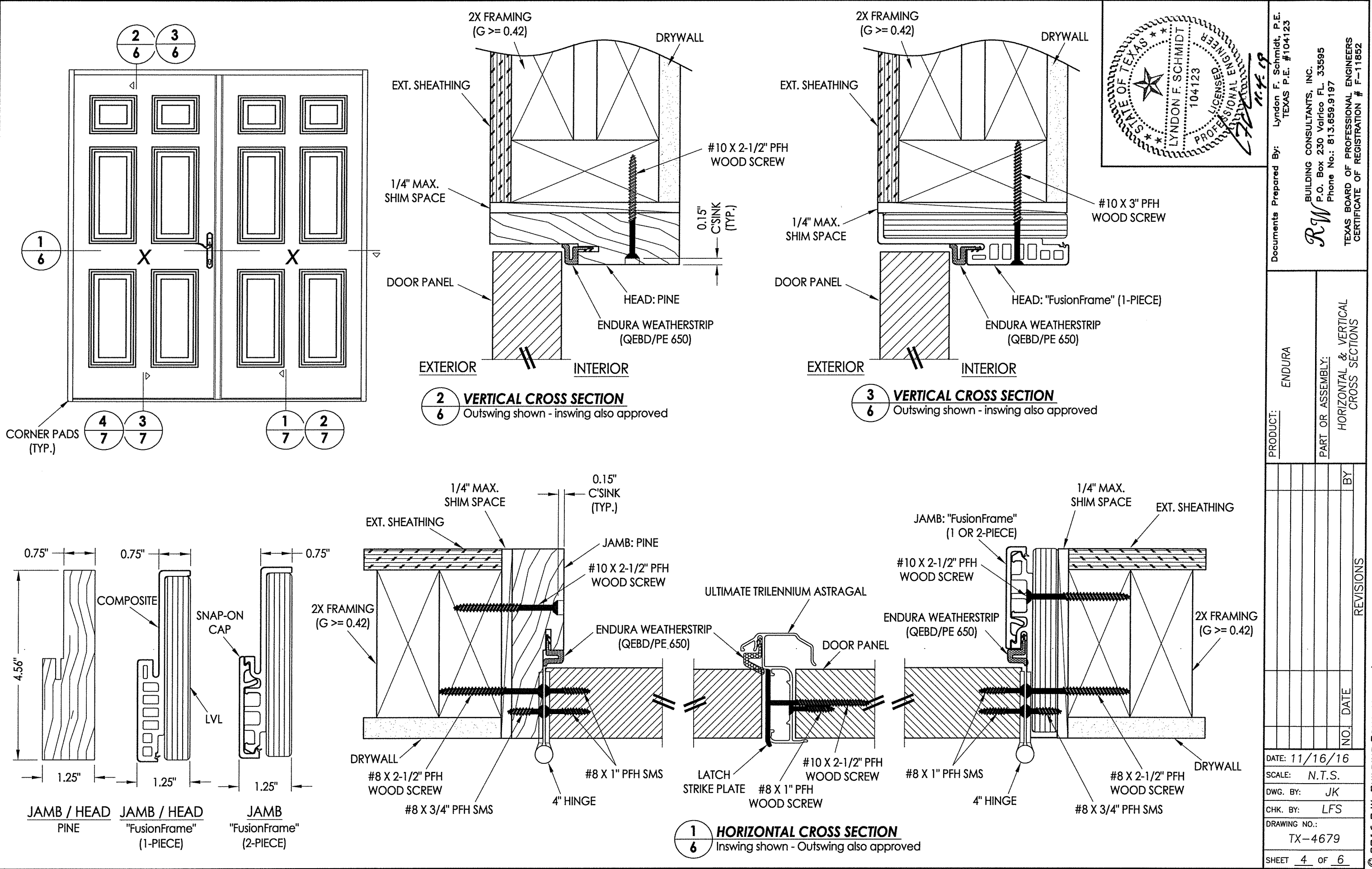

Documents Prepared By: Lyndon F. Schmidt, P.E.
 TEXAS P.E. #104123

RW BUILDING CONSULTANTS, INC.
 P.O. Box 230 Valrico FL, 33595
 Phone No.: 813.659.9197

TEXAS BOARD OF PROFESSIONAL ENGINEERS
 CERTIFICATE OF REGISTRATION # F-11852

PRODUCT: ENDURA

PART OR ASSEMBLY: HORIZONTAL & VERTICAL CROSS SECTIONS

NO.	DATE	BY	REVISIONS

DATE: 11/16/16
 SCALE: N.T.S.
 DWG. BY: JK
 CHK. BY: LFS
 DRAWING NO.: TX-4679
 SHEET 4 OF 6

R:\Clients\Endura PERMANENT\B - Texas Dept of Ins\TDI - DR-854 Masonite ST Opaque (TriLennium)\C - Drawings\TX-4678.79.81.82.dwg, 1.5

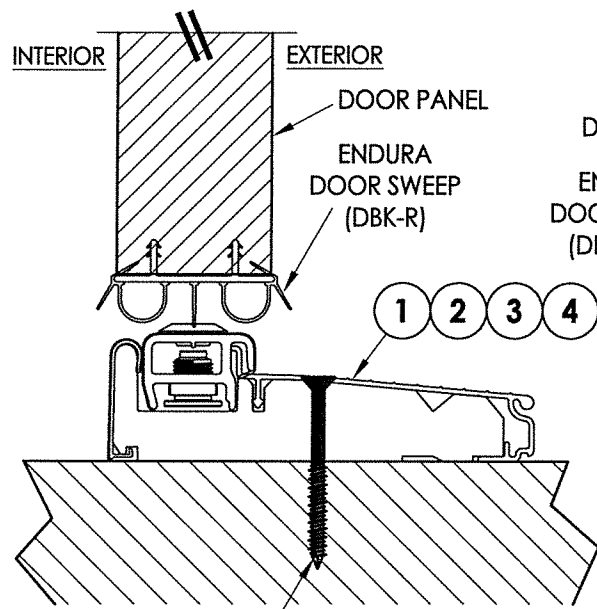

#10 X 2.5" PFH WOOD SCREW OR
1/4" X 2-3/4" ELCO OR ITW CONCRETE SCREW

1 VERTICAL CROSS SECTION
5 Inswing Adjustable Threshold

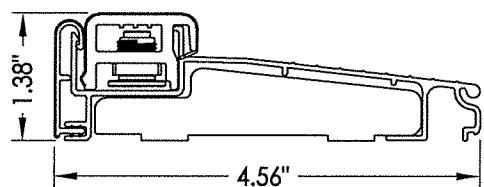

1 INSWING ADJUSTABLE THRESHOLD
ZAIL4565

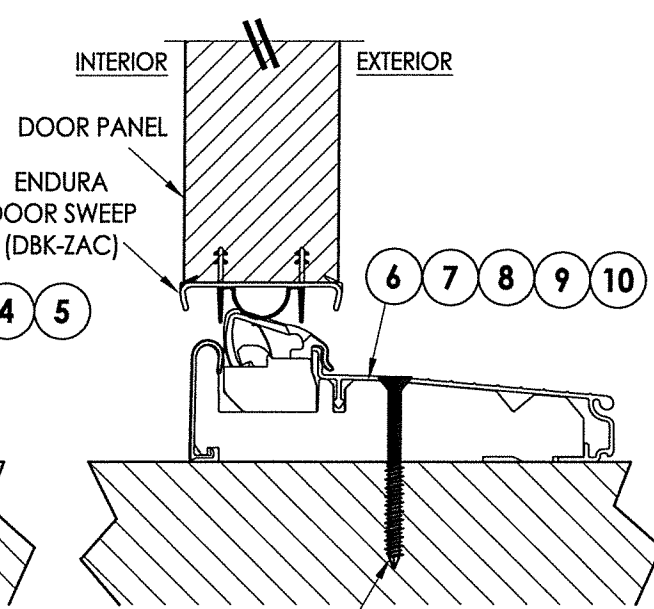

#10 X 2.5" PFH WOOD SCREW OR
1/4" X 2-3/4" ELCO OR ITW CONCRETE SCREW

2 VERTICAL CROSS SECTION
5 Inswing Articulating Threshold
w/ Pin Capture

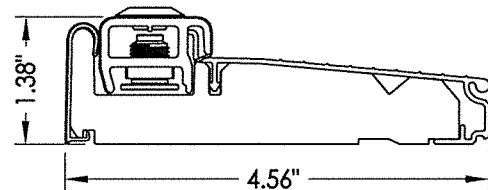

2 INSWING ADJUSTABLE THRESHOLD
ZAI4565FN

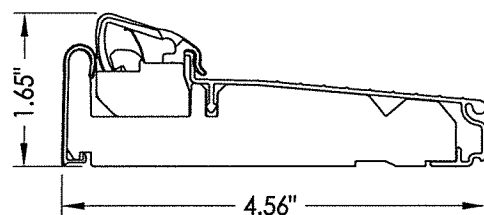

7 INSWING ARTICULATING THRESHOLD
ZAC4565FN

MAX. DESIGN PRESSURE = ±30 PSF

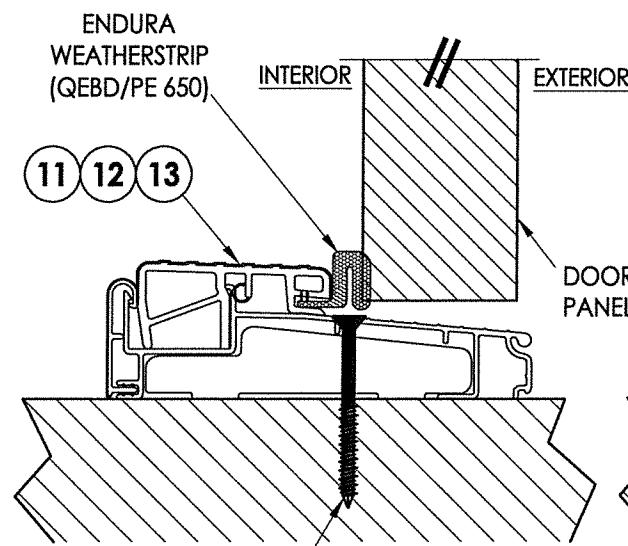

#10 X 2.5" PFH WOOD SCREW OR
1/4" X 2-3/4" ELCO OR ITW CONCRETE SCREW

3 VERTICAL CROSS SECTION
5 Outswing Bump Threshold

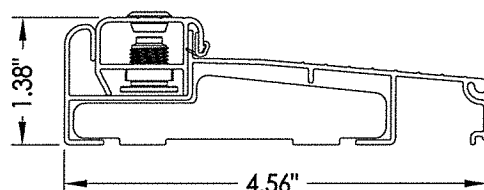

3 INSWING ADJUSTABLE THRESHOLD
ZAILAA4565

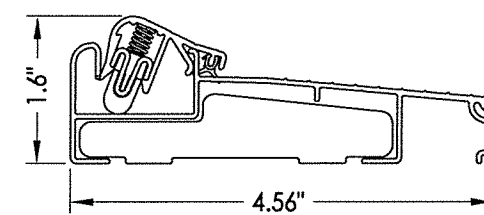

8 INSWING ARTICULATING THRESHOLD
ZACLAA4565

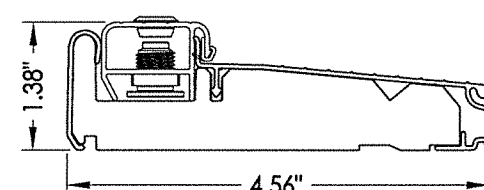

4 INSWING ADJUSTABLE THRESHOLD
ZIAAA4565FN

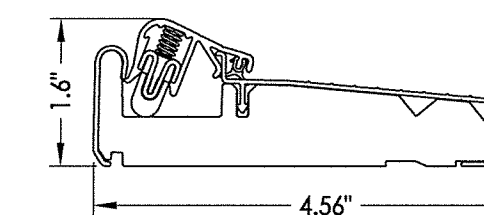

9 INSWING ARTICULATING THRESHOLD
ZACAA4565FN

MAX. DESIGN PRESSURE = ±30 PSF

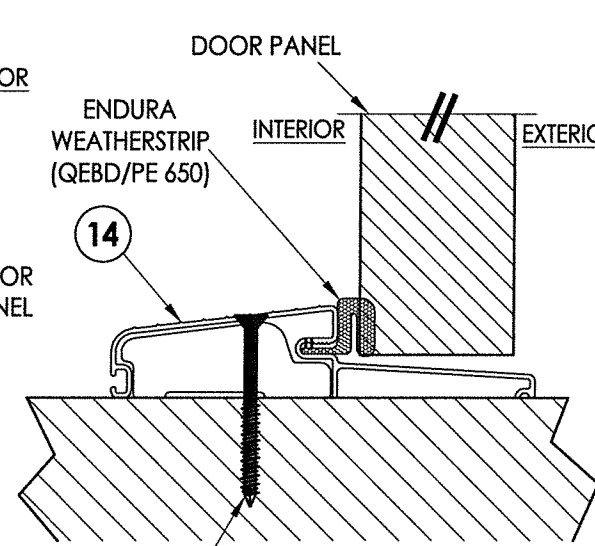

#10 X 2.5" PFH WOOD SCREW OR
1/4" X 2-3/4" ELCO OR ITW CONCRETE SCREW

4 VERTICAL CROSS SECTION
5 Outswing Bump Threshold

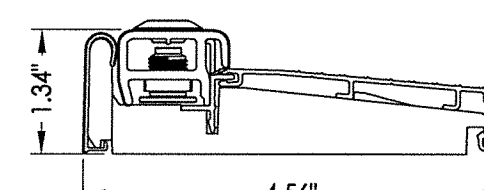

5 INSWING ADJUSTABLE THRESHOLD
ZAI4565RDS

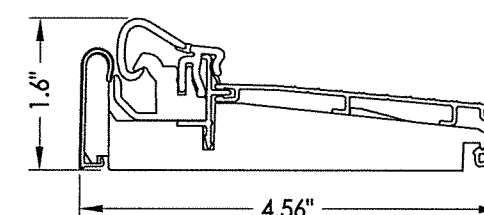

10 INSWING ARTICULATING THRESHOLD
ZAC4565RDS

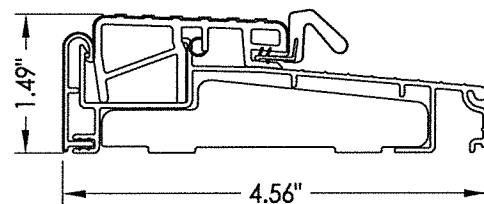

11 OUTSWING THRESHOLD
ZOBL4565

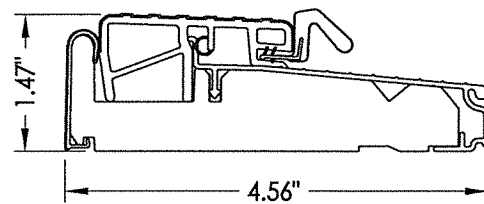

12 OUTSWING THRESHOLD
ZOB4565FN

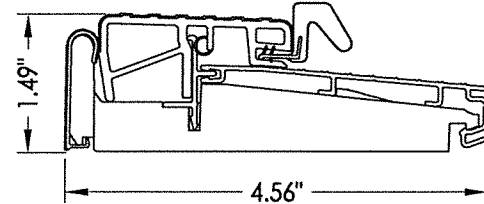

13 OUTSWING THRESHOLD
ZOB4565RDS

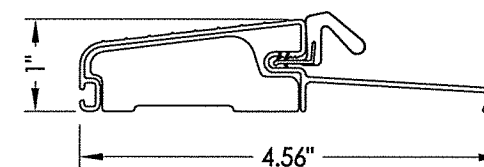

14 OUTSWING THRESHOLD
FOB4566

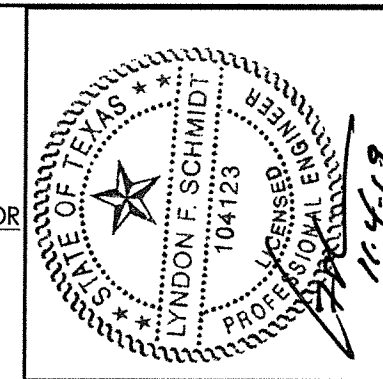

11-4-19

Documents Prepared By: Lyndon F. Schmidt, P.E.
TEXAS P.E. #104123

RW BUILDING CONSULTANTS, INC.
P.O. Box 230 Valrico FL 33595
Phone No.: 813.659.9197

TEXAS BOARD OF PROFESSIONAL ENGINEERS
CERTIFICATE OF REGISTRATION # F-11852

PRODUCT: ENDURA

PART OR ASSEMBLY:

VERTICAL CROSS SECTIONS

NO.	DATE	BY	REVISIONS
1	11/4/19	LFS	ADD "FusionFrame" OPTION & UPDATE TO 2018 IBC/IRC CODE

DATE: 11/16/16

SCALE: N.T.S.

DWG. BY: JK

CHK. BY: LFS

DRAWING NO.: TX-4679

SHEET 5 OF 6

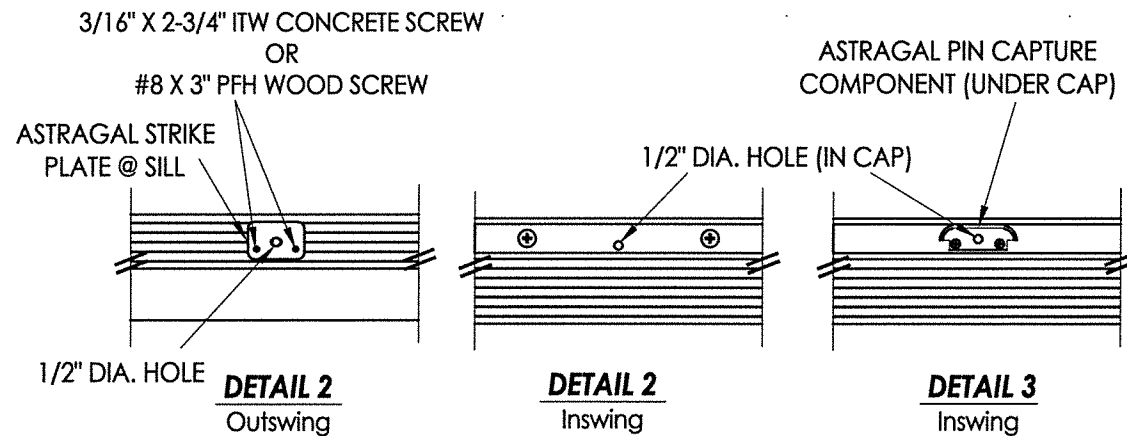
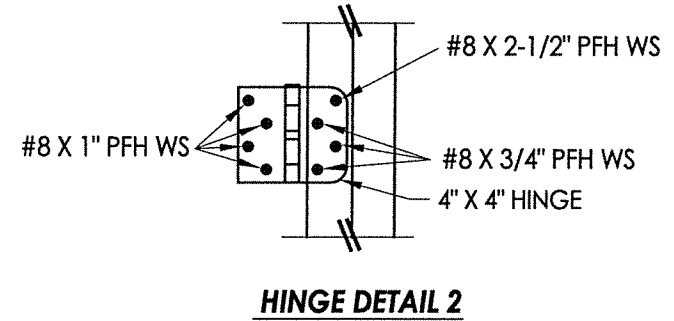
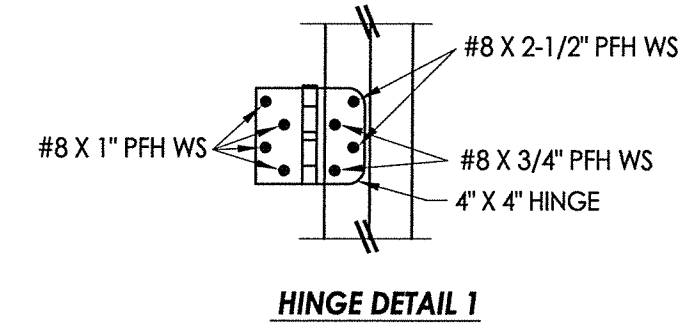
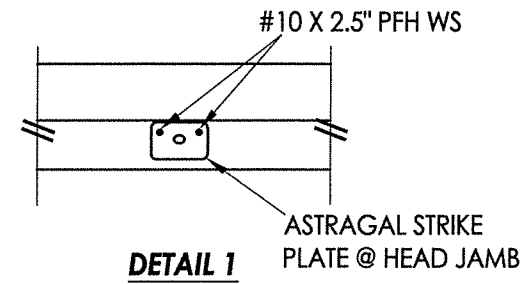
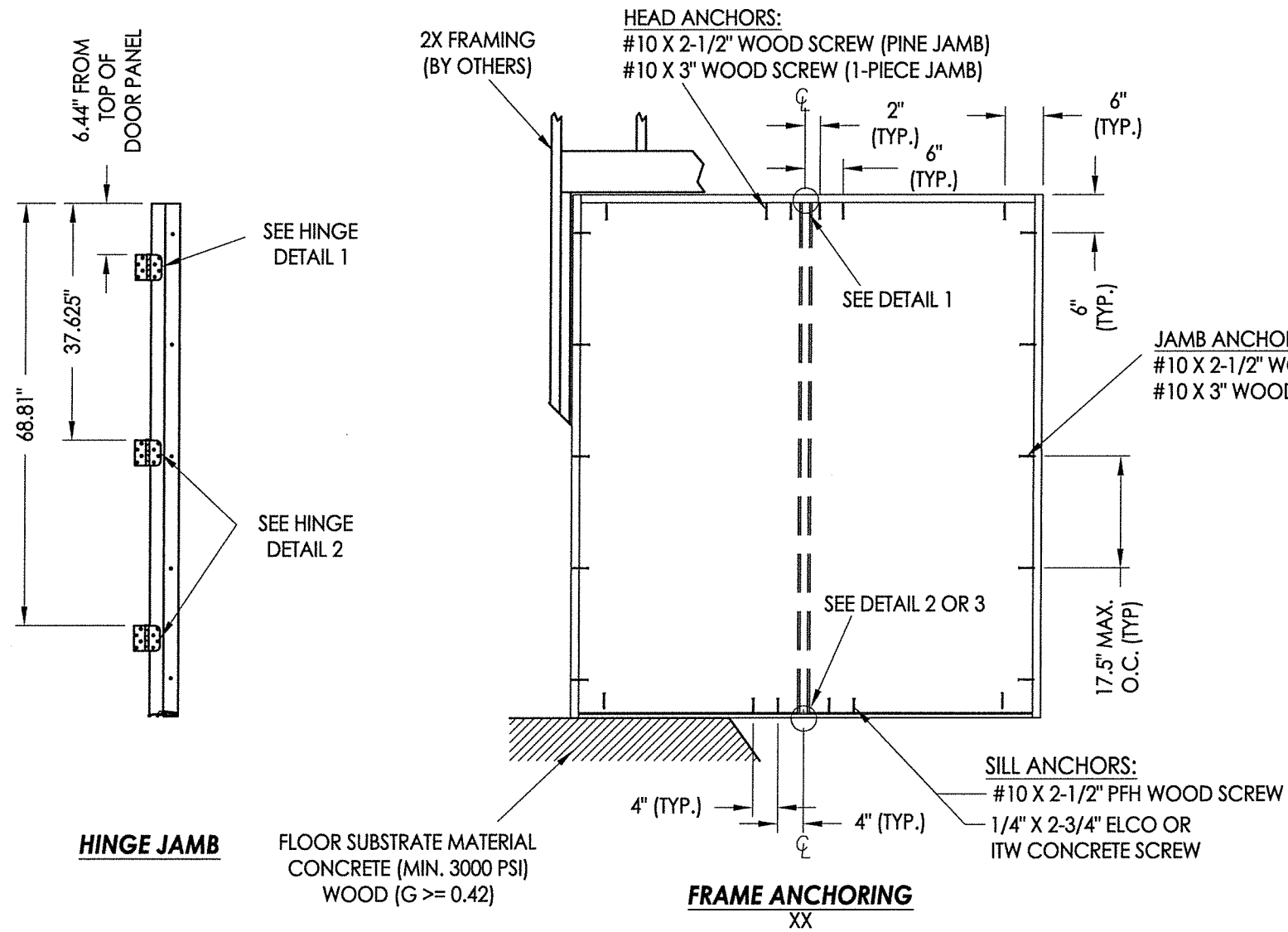

JAMB NOTES:

THE PINE OR "FusionFrame" 1-PIECE JAMB MAY BE INSTALLED @ THE HEAD OR SIDE JAMB.
THE FusionFrame" 2-PIECE JAMB MAY BE INSTALLED @ THE SIDE JAMBS ONLY.

CONCRETE ANCHOR NOTES:

- Concrete anchor locations at the corners may be adjusted to maintain the min. edge distance to mortar joints.
- Concrete anchor locations noted as "MAX. ON CENTER" must be adjusted to maintain the min. edge distance to mortar joints, additional concrete anchors may be required to ensure the "MAX. ON CENTER" dimension are not exceeded.
- Concrete anchor table:

ANCHOR TYPE	ANCHOR SIZE	MIN. EMBEDMENT	MIN. CLEARANCE TO MASONRY EDGE	MIN. CLEARANCE TO ADJACENT ANCHOR
ITW TAPCON®	3/16"	1-3/4"	3"	1-1/2"
ITW TAPCON®	1/4"	1-3/4"	1-1/2"	4"
ELCO ULTRACON®	1/4"	1-3/4"	1"	4"

WOOD SCREW INSTALLATION NOTES:

- Maintain a minimum 5/8" edge distance, 1" end distance, & 1" o.c. spacing of wood screws to prevent the splitting of wood.

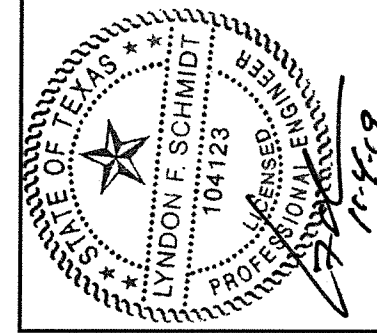

Documents Prepared By: Lyndon F. Schmidt, P.E.
TEXAS P.E. #104123

RW BUILDING CONSULTANTS, INC.
P.O. Box 230 Valrico FL, 33595
Phone No.: 813.669.9197

TEXAS BOARD OF PROFESSIONAL ENGINEERS
CERTIFICATE OF REGISTRATION # F-11852

PRODUCT:	ENDURA
PART OR ASSEMBLY:	FRAME ANCHORING
DATE:	11/16/16
SCALE:	N.T.S.
DWG. BY:	JK
CHK. BY:	LFS
DRAWING NO.:	TX-4679
SHEET	6 OF 6

REVISIONS