



AMERICA'S DOORMAKER  
631 N. FIRST ST. WEST BRANCH, MI 48661

## GLAZED STEEL DOORS DOUBLES w/ or w/o SIDELITES IN SWING / OUT SWING "NON-IMPACT"

### EVALUATED FOR USE IN THE STATE OF TEXAS

The Steel Door system described herein complies with the 2018 International Residential Code (IRC), Sections R301 & R609 and the 2018 International Building Code (IBC), Sections 1404.13, 1609, 1709.5, 2403 and 2404 subject to the following conditions:

1. Anchors shall be as listed and spaced as shown in the details. Anchor embedment to base material shall be beyond wall dressing or stucco.
2. When used in areas requiring wind-borne debris protection this product is required to be protected with an impact resistant covering that complies with Section R301.2.1.2 of the IRC and Section 1609.1.2 of the IBC.
3. Allowable design pressure requirements must be equal to or less than the design pressure rating shown in the design pressure chart, sheet 1 of this drawing.
4. Conditions not covered by this drawing are subject to further engineering analysis.

#### TABLE OF CONTENTS

SHEET#	DESCRIPTION
1	Typical elevations, design pressures & general notes
2	Door & Sidelite panel details
3	Elevations
4	Vertical cross sections
5	Horizontal cross sections
6	Hardware details
7	Frame anchoring
8	Bill of materials and components

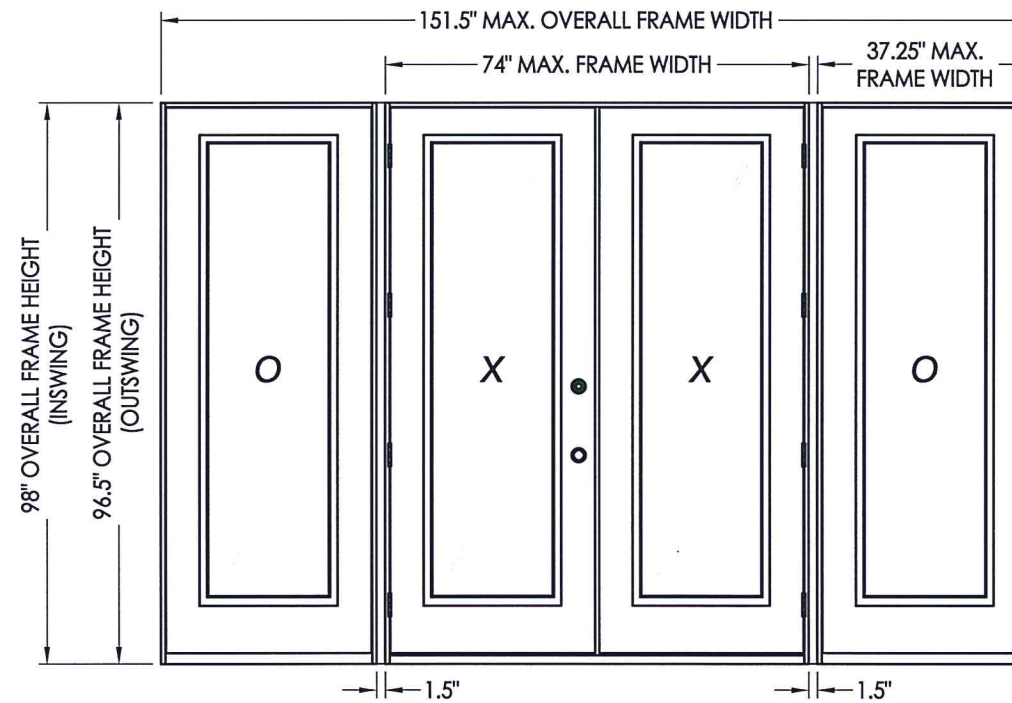
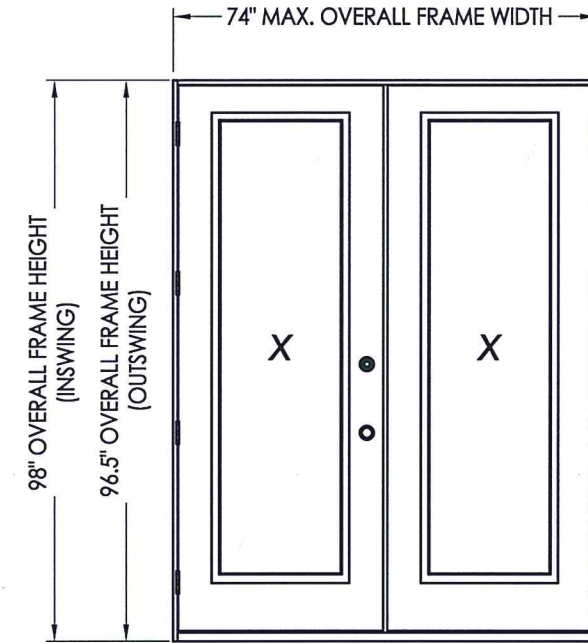

CONFIG.	MAX. FRAME DIMENSION	DESIGN PRESSURE (PSF) INSWING		DESIGN PRESSURE (PSF) OUTSWING	
		POS.	NEG.	POS.	NEG.
XX	74.0" x 98.0"	+40.0	-45.0	+40.0	-40.0
OXXO	151.5" x 98.0"	+40.0	-45.0	+40.0	-40.0

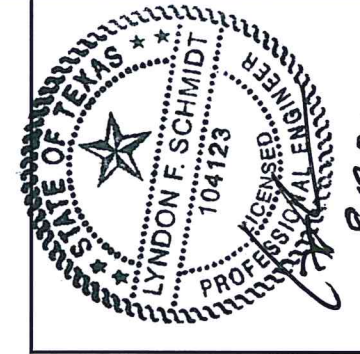

Documents Prepared By: Lyndon F. Schmidt, P.E.  
TEXAS P.E. #104123

RW BUILDING CONSULTANTS, INC.  
P.O. Box 230 Valrico FL 33595  
Phone No.: 813.659.9197

TEXAS BOARD OF PROFESSIONAL ENGINEERS  
CERTIFICATE OF REGISTRATION # F-11852

PRODUCT: TAYLOR DOOR STEEL DOOR

PART OR ASSEMBLY: TYPICAL ELEVATION, DESIGN PRESSURES & GENERAL NOTES

NO.	DATE	DESCRIPTION	BY
1	7/18/20	UPDATE TO 2018 IBC/IRC CODE	LFS

DATE: 11/3/14  
SCALE: N.T.S.  
DWG. BY: JK  
CHK. BY: LFS  
DRAWING NO.: TX-4498  
SHEET 1 OF 8



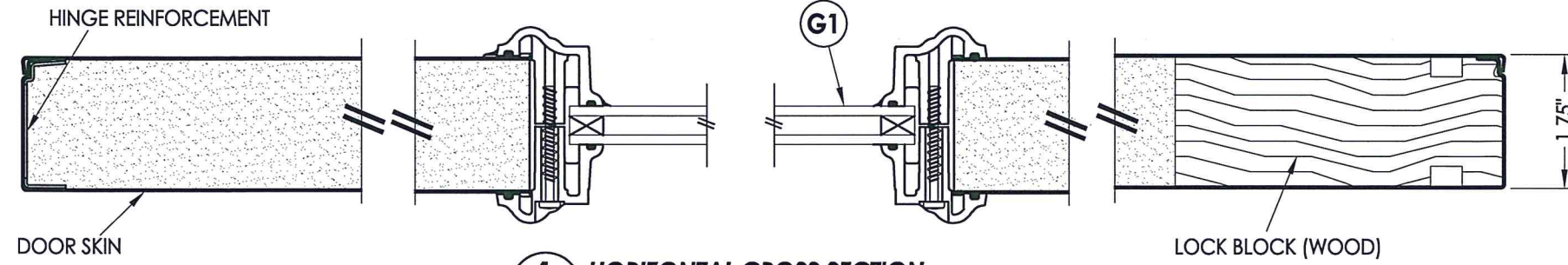

**1**  
**2** HORIZONTAL CROSS SECTION

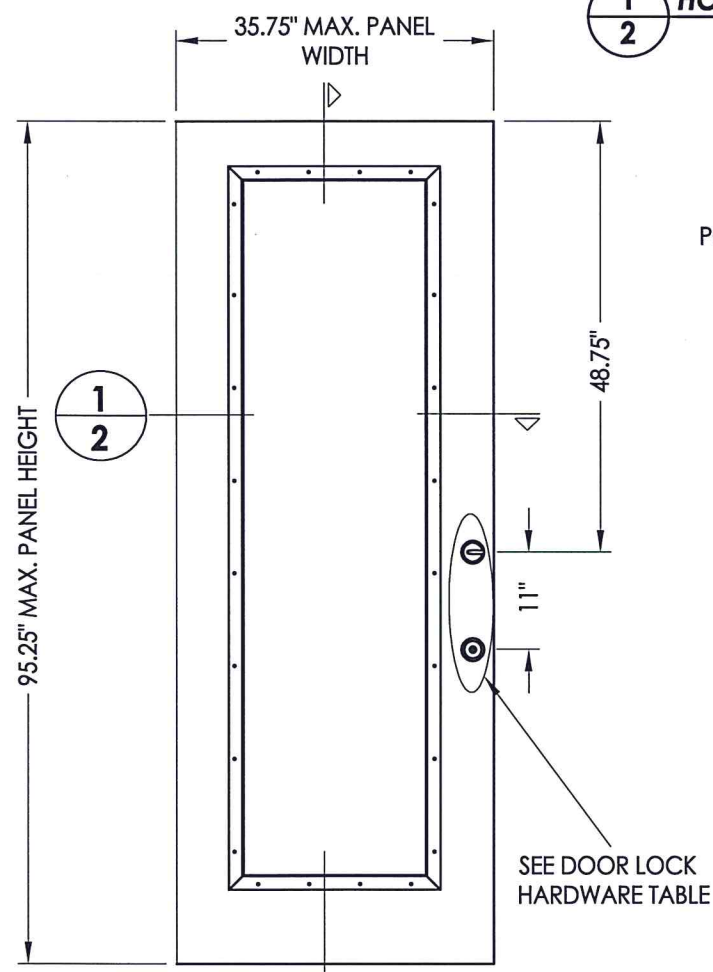

- 40** TAYLOR DOOR DOOR PANEL
- 50** TAYLOR DOOR SIDELITE PANEL

DOOR SKIN: 0.022" MIN. THK. STEEL  
CORE MATERIAL: POLYURETHANE FOAM

HARDWARE CHART	
MANUFACTURER	MODEL
YALE	KNOB: NEW TRADITIONS DEADBOLT: NEW TRADITIONS (800 SERIES)
SCHLAGE	KNOB/LEVER: "F" SERIES DEADBOLT: B60/62

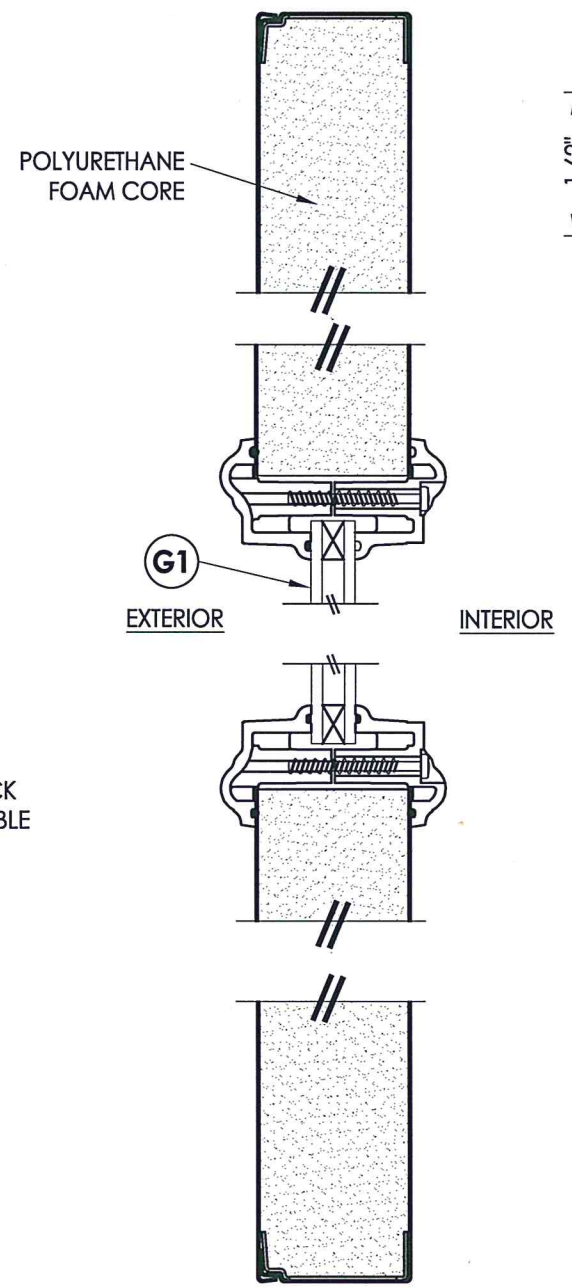

**2**  
**2** VERTICAL CROSS SECTION

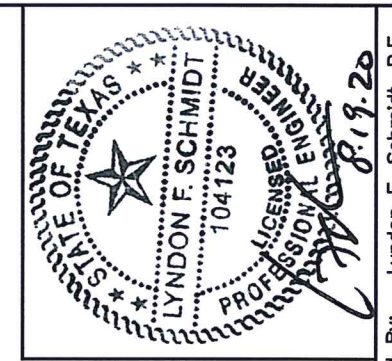
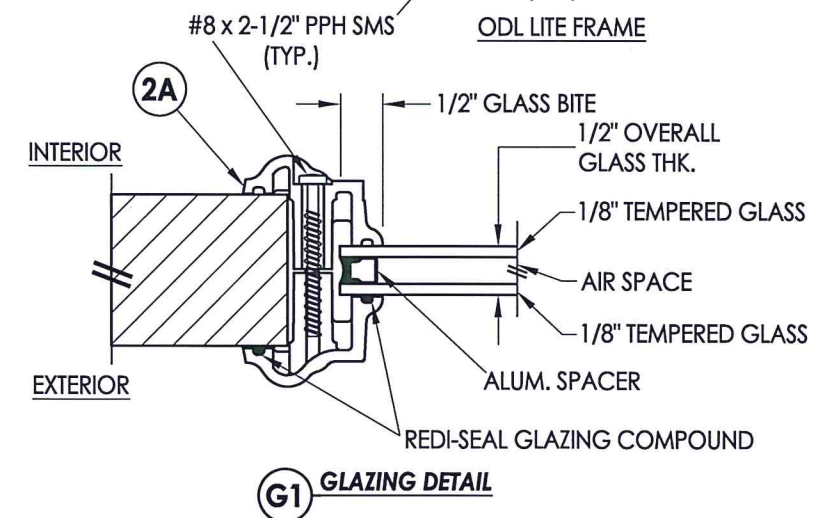
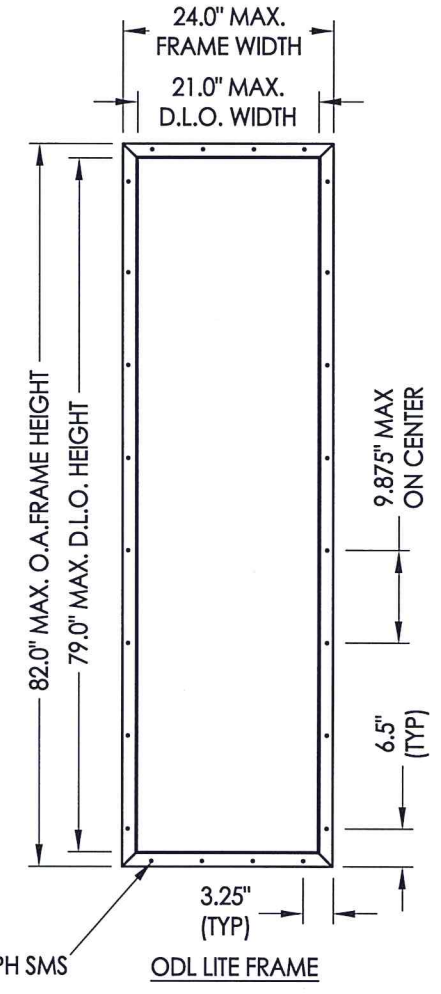
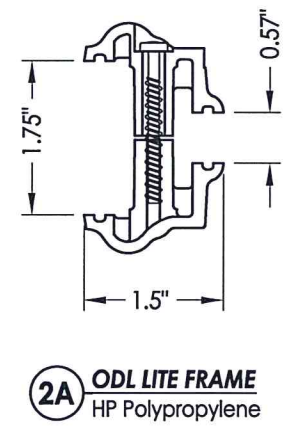
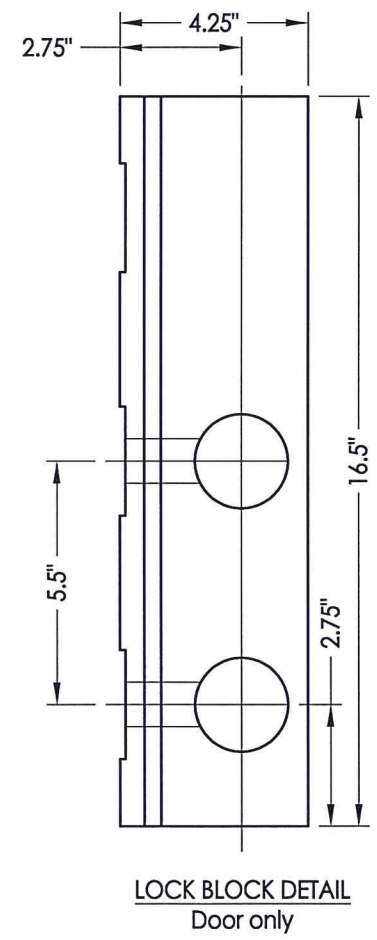
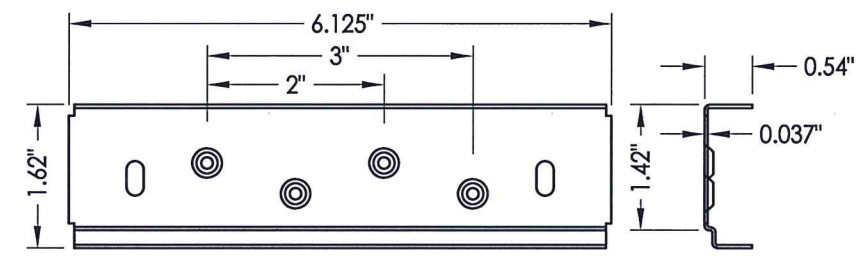

Documents Prepared By: Lyndon F. Schmidt, P.E.  
TEXAS P.E. #104123

**RW** BUILDING CONSULTANTS, INC.  
P.O. Box 230 Valrico FL 33595  
Phone No.: 813.659.9197

TEXAS BOARD OF PROFESSIONAL ENGINEERS  
CERTIFICATE OF REGISTRATION # F-11852

PRODUCT:	TAYLOR DOOR STEEL DOOR
PART OR ASSEMBLY:	DOOR & SIDELITE PANEL DETAILS
DATE:	11/3/14
SCALE:	N.T.S.
DWG. BY:	JK
CHK. BY:	LFS
DRAWING NO.:	TX-4498
SHEET	2 OF 8

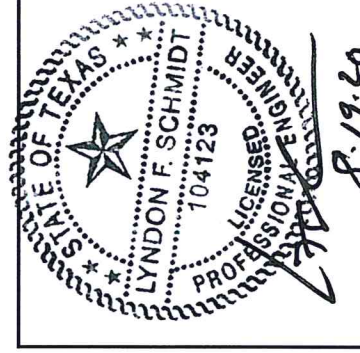
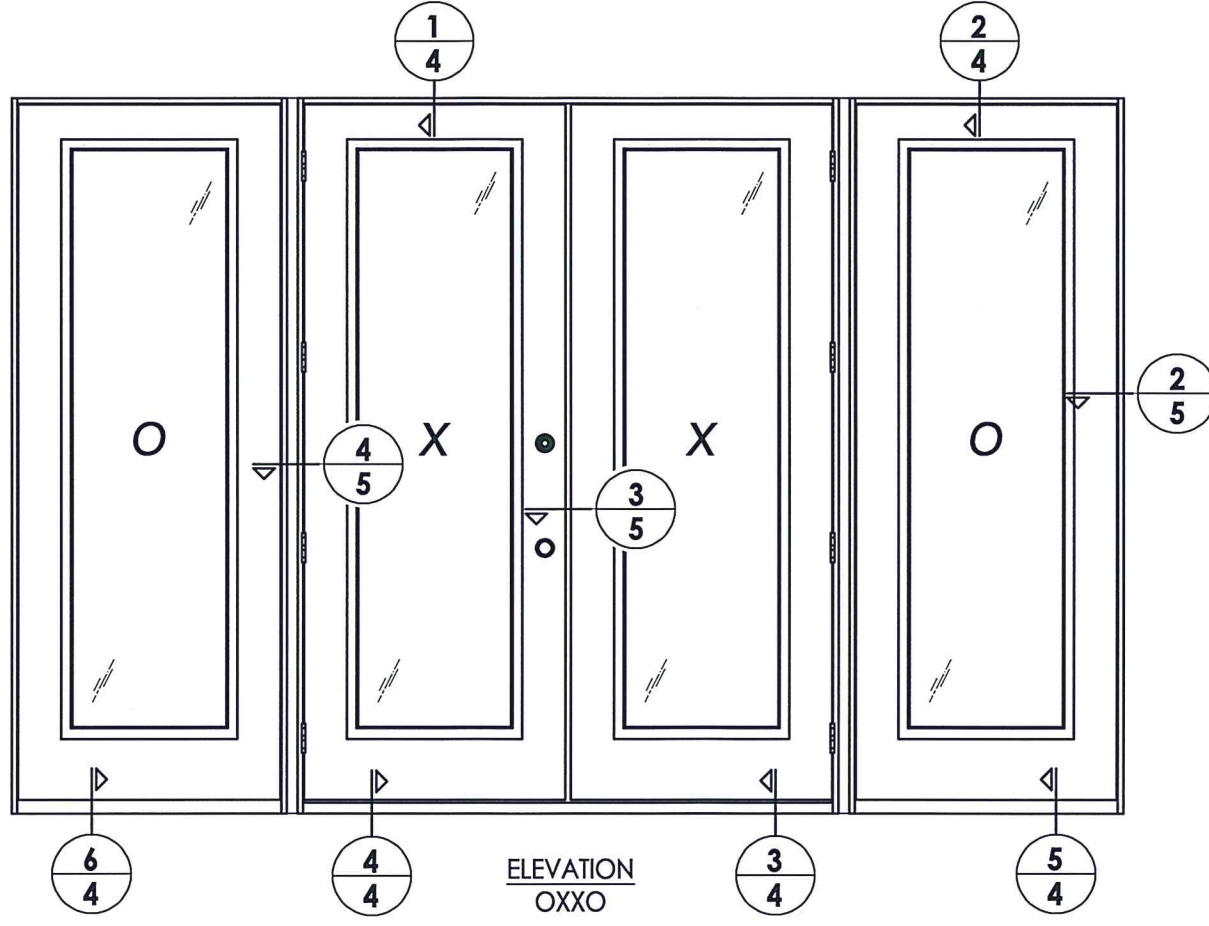
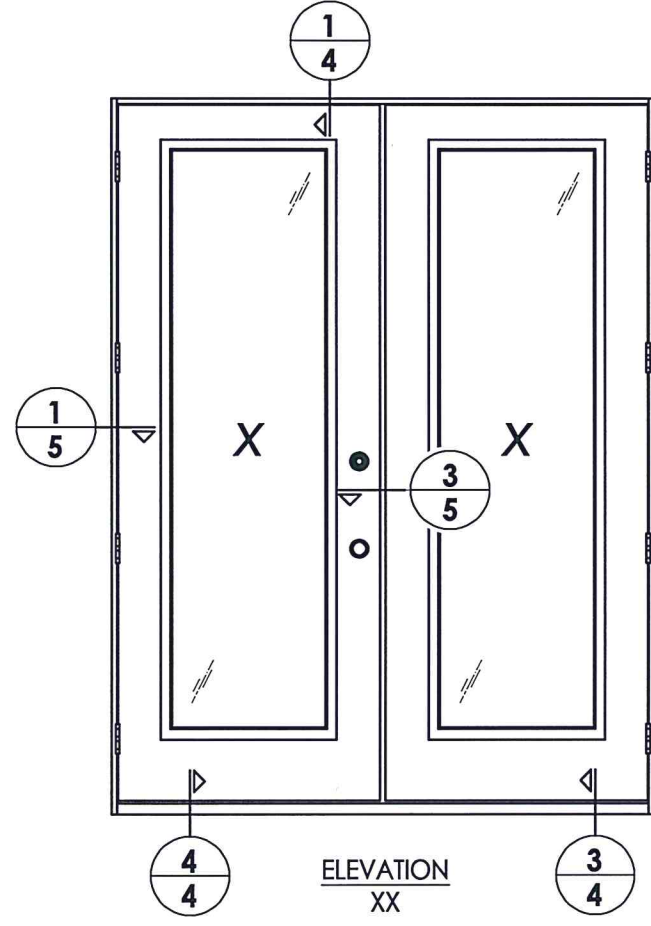

Documents Prepared By: Lyndon F. Schmidt, P.E.  
TEXAS P.E. #104123

**RW** BUILDING CONSULTANTS, INC.  
P.O. Box 230 Valrico FL 33595  
Phone No.: 813.659.9197

TEXAS BOARD OF PROFESSIONAL ENGINEERS  
CERTIFICATE OF REGISTRATION # F-11852

PRODUCT: TAYLOR DOOR  
STEEL DOOR

PART OR ASSEMBLY:  
ELEVATIONS

NO.	DATE	DESCRIPTION	BY
1	7/18/20	UPDATE TO 2018 IBC/IRC CODE	LFS

DATE: 11/3/14  
SCALE: N.T.S.  
DWG. BY: JK  
CHK. BY: LFS  
DRAWING NO.: TX-4498  
SHEET 3 OF 8



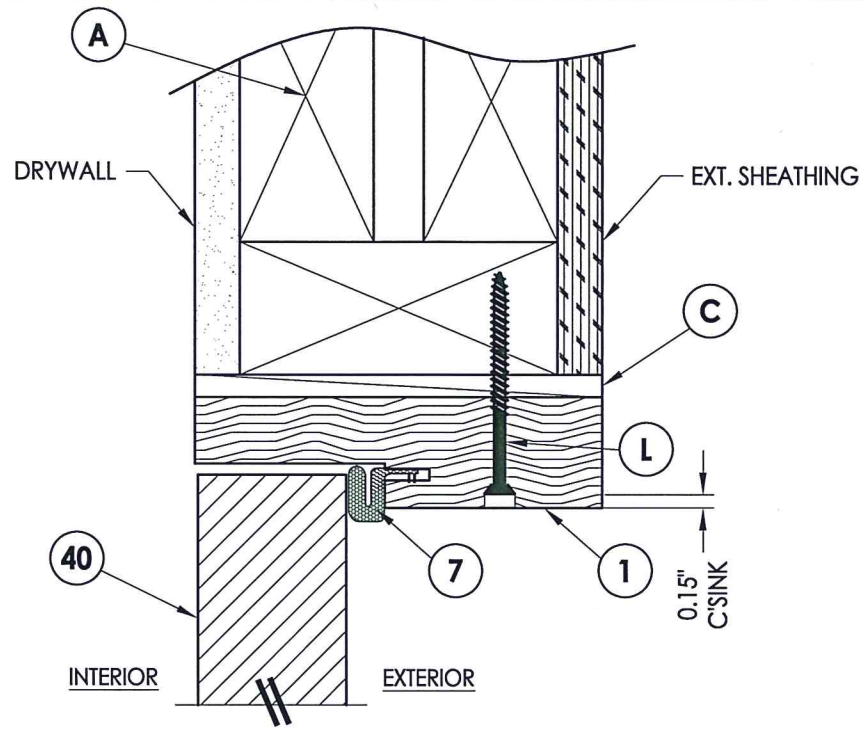

**1 VERTICAL CROSS SECTION**  
4 Inswing shown (Outswing similar)

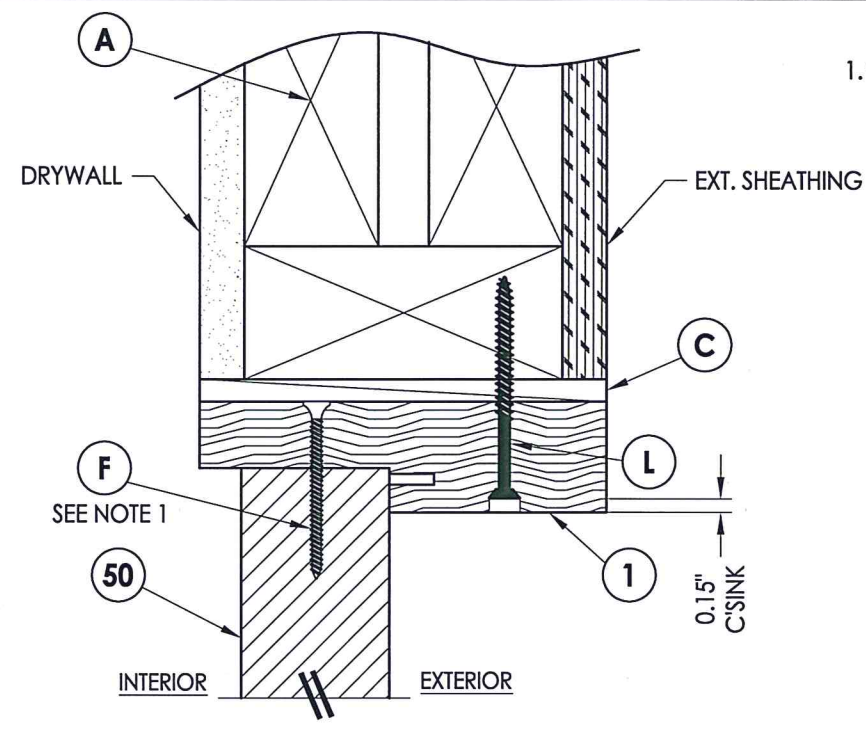

**2 VERTICAL CROSS SECTION**  
4 Inswing shown (Outswing similar)

NOTE:  
1. Spacing for item F or K @ head & sill: 6" from each end plus 1 @ centerline (3 total).

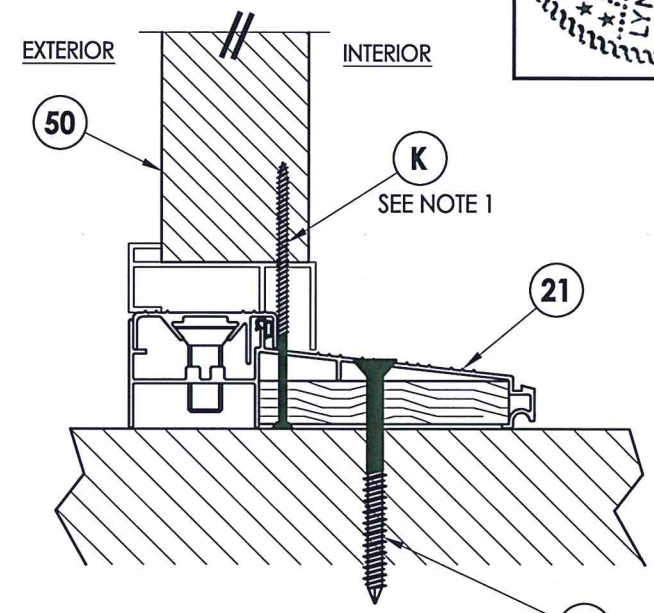

**5 VERTICAL CROSS SECTION**  
4 Inswing sill

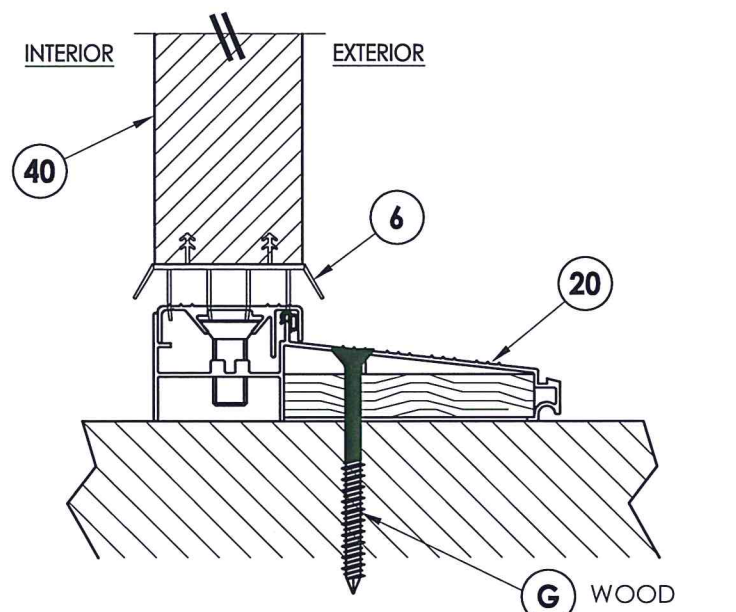

**3 VERTICAL CROSS SECTION**  
4 Inswing sill

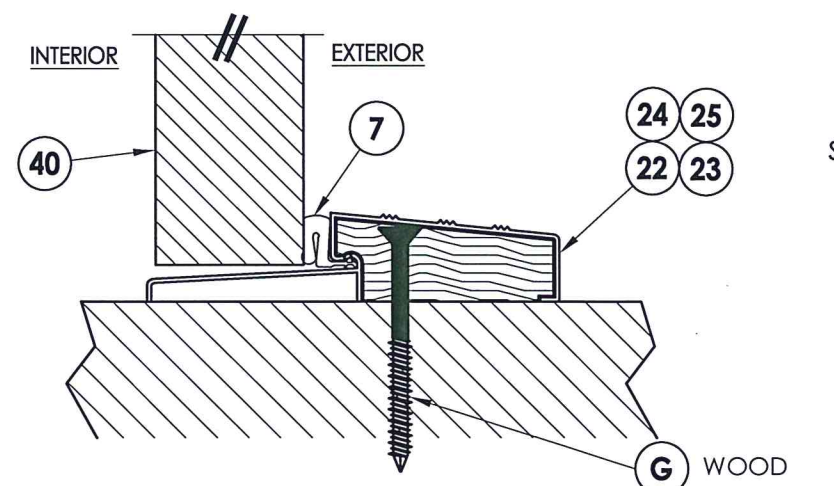

**4 VERTICAL CROSS SECTION**  
4 Outswing sill

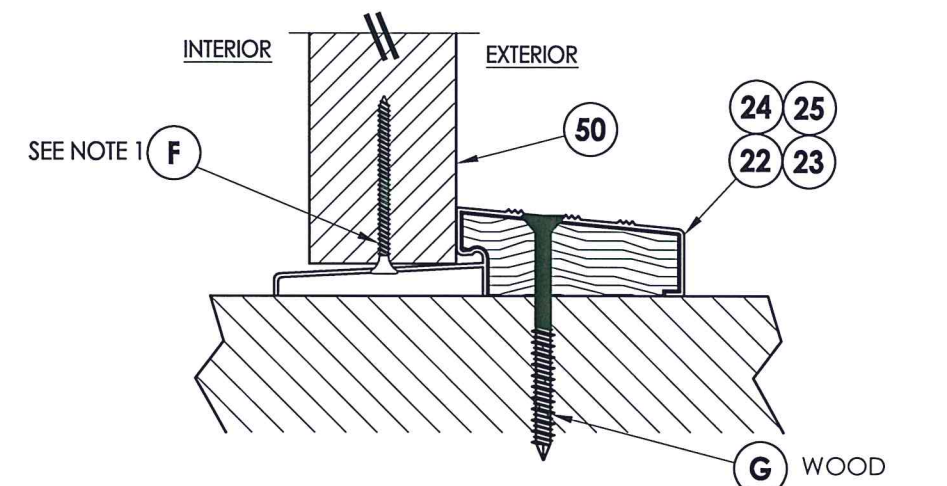

**6 VERTICAL CROSS SECTION**  
4 Outswing sill



Documents Prepared By: Lyndon F. Schmidt, P.E.  
TEXAS P.E. #104723

**RW** BUILDING CONSULTANTS, INC.  
P.O. Box 230 Valrico FL, 33595  
Phone No.: 813.659.9197

TEXAS BOARD OF PROFESSIONAL ENGINEERS  
CERTIFICATE OF REGISTRATION # F-11852

PRODUCT: TAYLOR DOOR  
STEEL DOOR

PART OR ASSEMBLY: VERTICAL CROSS SECTIONS

NO.	DATE	DESCRIPTION	LFS	BY
1	7/18/20	UPDATE TO 2018 IBC/IRC CODE		

DATE: 11/3/14  
SCALE: N.T.S.  
DWG. BY: JK  
CHK. BY: LFS  
DRAWING NO.: TX-4498  
SHEET 4 OF 8



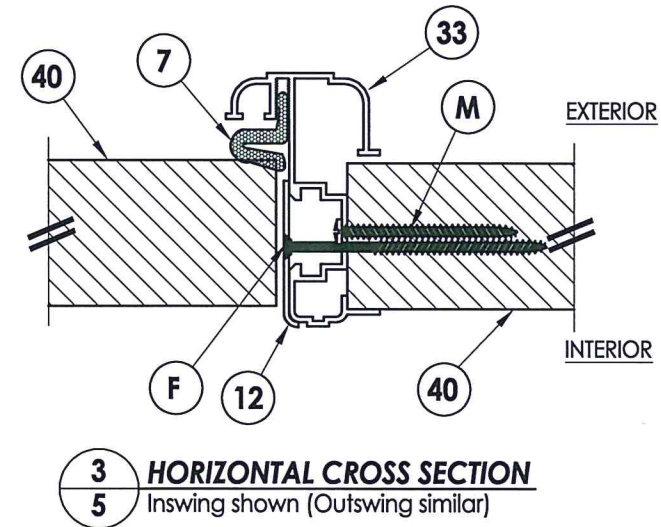
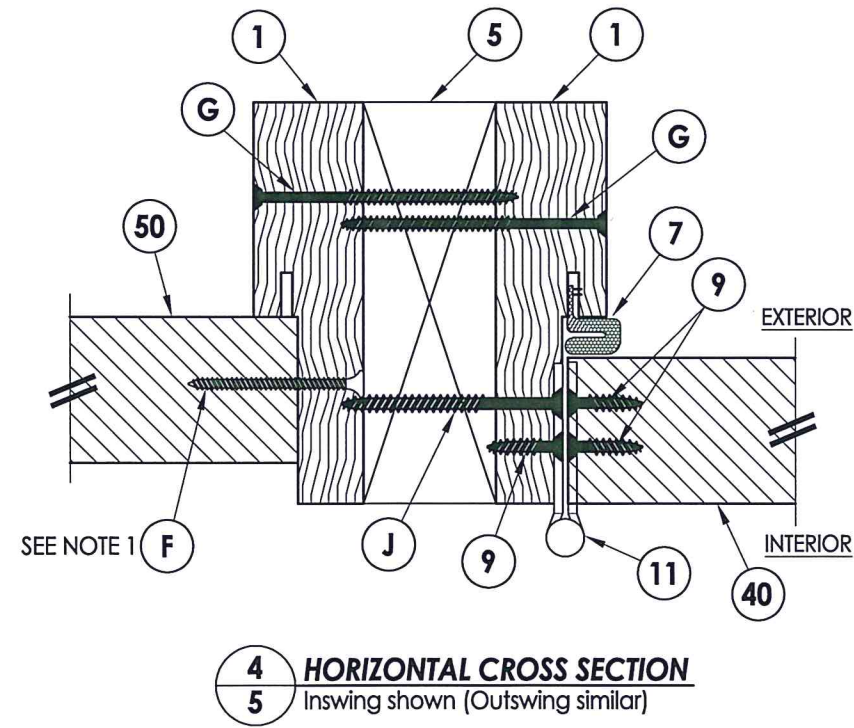
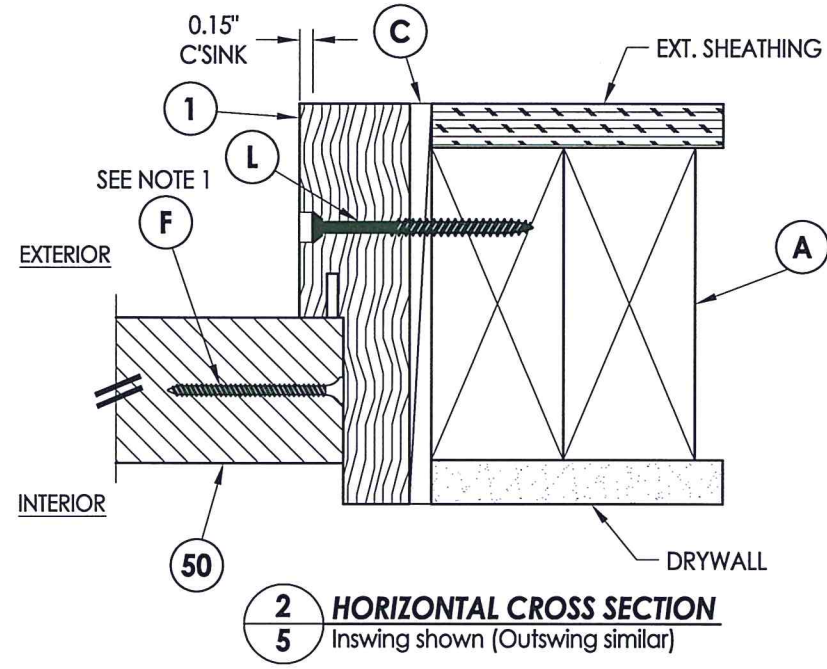
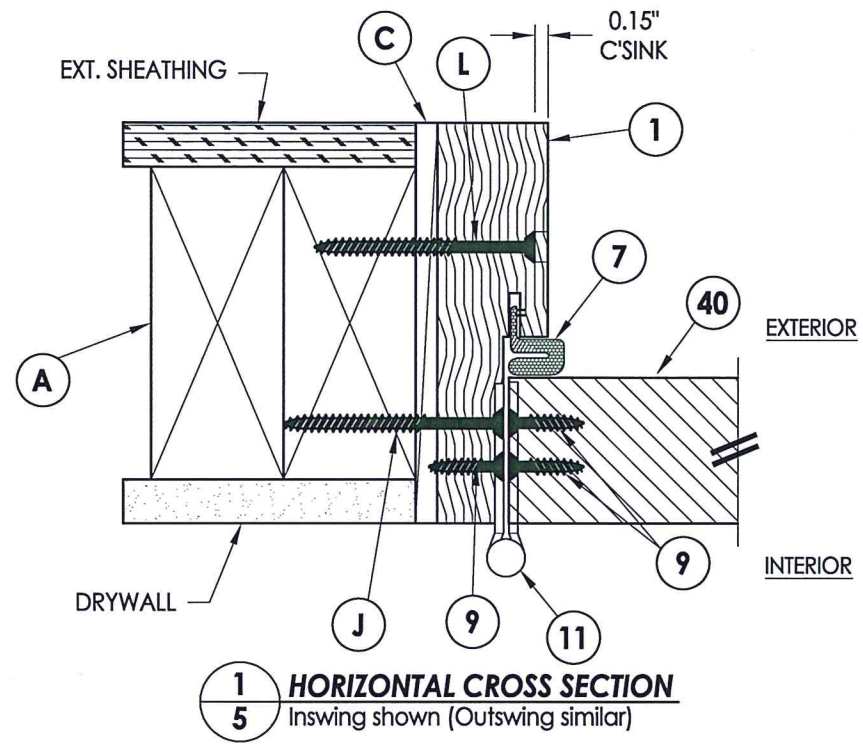

NOTE:  
 1. Spacing for item F: 6" from each end and 6 more equally spaced along sidelite jamb (8 total).

Documents Prepared By: Lyndon F. Schmidt, P.E.  
 TEXAS P.E. #104123  
**RW** BUILDING CONSULTANTS, INC.  
 P.O. Box 230 Valrico FL 33595  
 Phone No.: 813.659.9197  
 TEXAS BOARD OF PROFESSIONAL ENGINEERS  
 CERTIFICATE OF REGISTRATION # F-11852

PRODUCT:	TAYLOR DOOR STEEL DOOR	
PART OR ASSEMBLY:	HORIZONTAL CROSS SECTIONS	
NO.	DATE	REVISIONS
1	7/18/20	UPDATE TO 2018 IBC/IRC CODE
LFS	BY	
DATE: 11/3/14		
SCALE: N.T.S.		
DWG. BY: JK		
CHK. BY: LFS		
DRAWING NO.: TX-4498		
SHEET 5 OF 8		

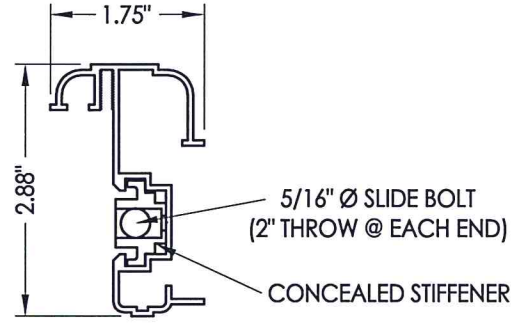
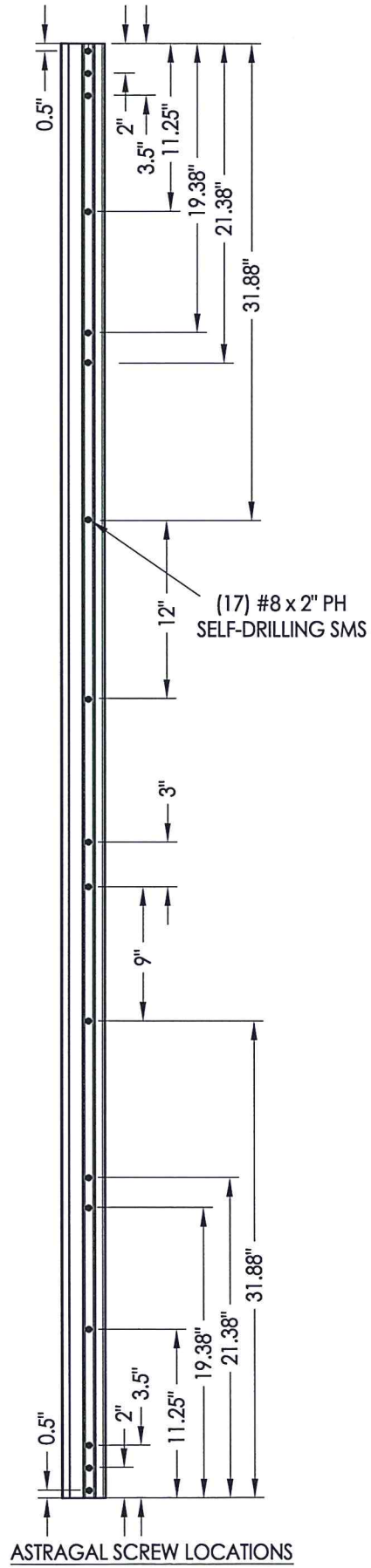

**33** ASTRAGAL  
DLP

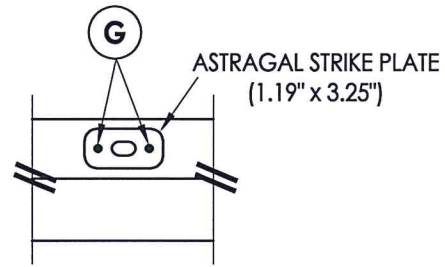

**ASTRAGAL BOLT DETAIL**  
Strike Plate @ Head

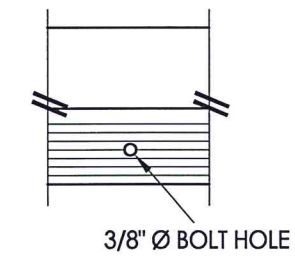

**ASTRAGAL BOLT DETAIL**  
Outswing Threshold

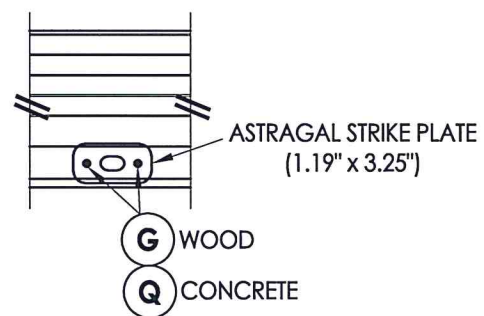

**ASTRAGAL BOLT DETAIL**  
Inswing Threshold

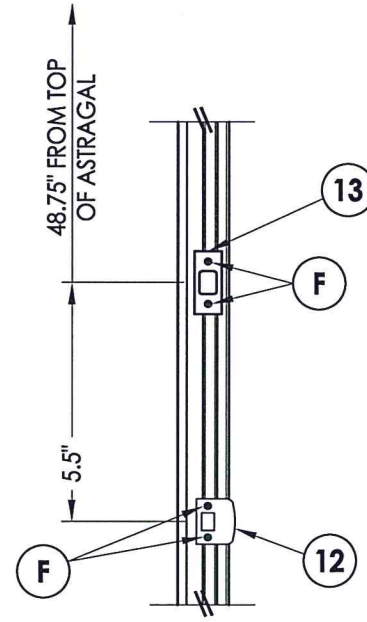

**LATCH AND DEADBOLT DETAILS**

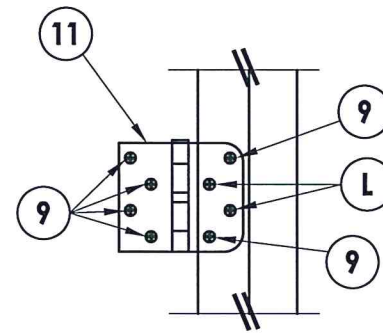

**HINGE DETAIL**

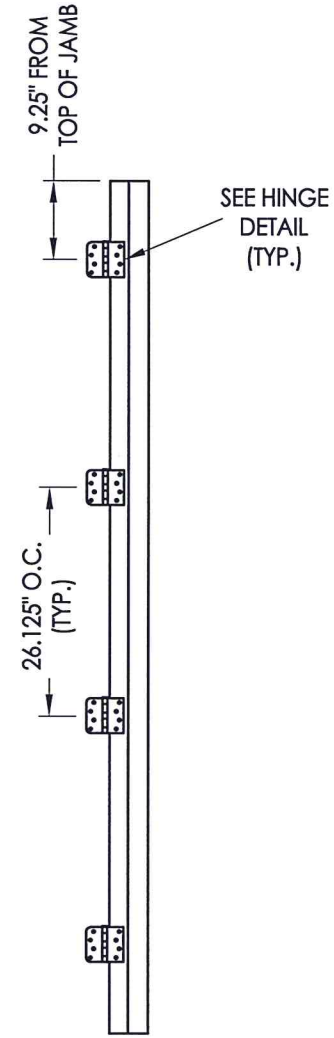

**HINGE JAMB**



Documents Prepared By: Lyndon F. Schmidt, P.E.  
TEXAS P.E. #104123

**RW** BUILDING CONSULTANTS, INC.  
P.O. Box 230 Valrico FL 33595  
Phone No.: 813.659.9197

TEXAS BOARD OF PROFESSIONAL ENGINEERS  
CERTIFICATE OF REGISTRATION # F-11852

PRODUCT:	TAYLOR DOOR STEEL DOOR	
PART OR ASSEMBLY:	HARDWARE DETAILS	
NO.	DATE	REVISIONS
1	7/18/20	UPDATE TO 2018 IBC/IRC CODE
		LFS
		BY
DATE:	11/3/14	
SCALE:	N.T.S.	
DWG. BY:	JK	
CHK. BY:	LFS	
DRAWING NO.:	TX-4498	
SHEET	6	OF 8



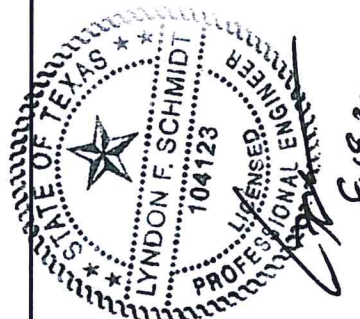
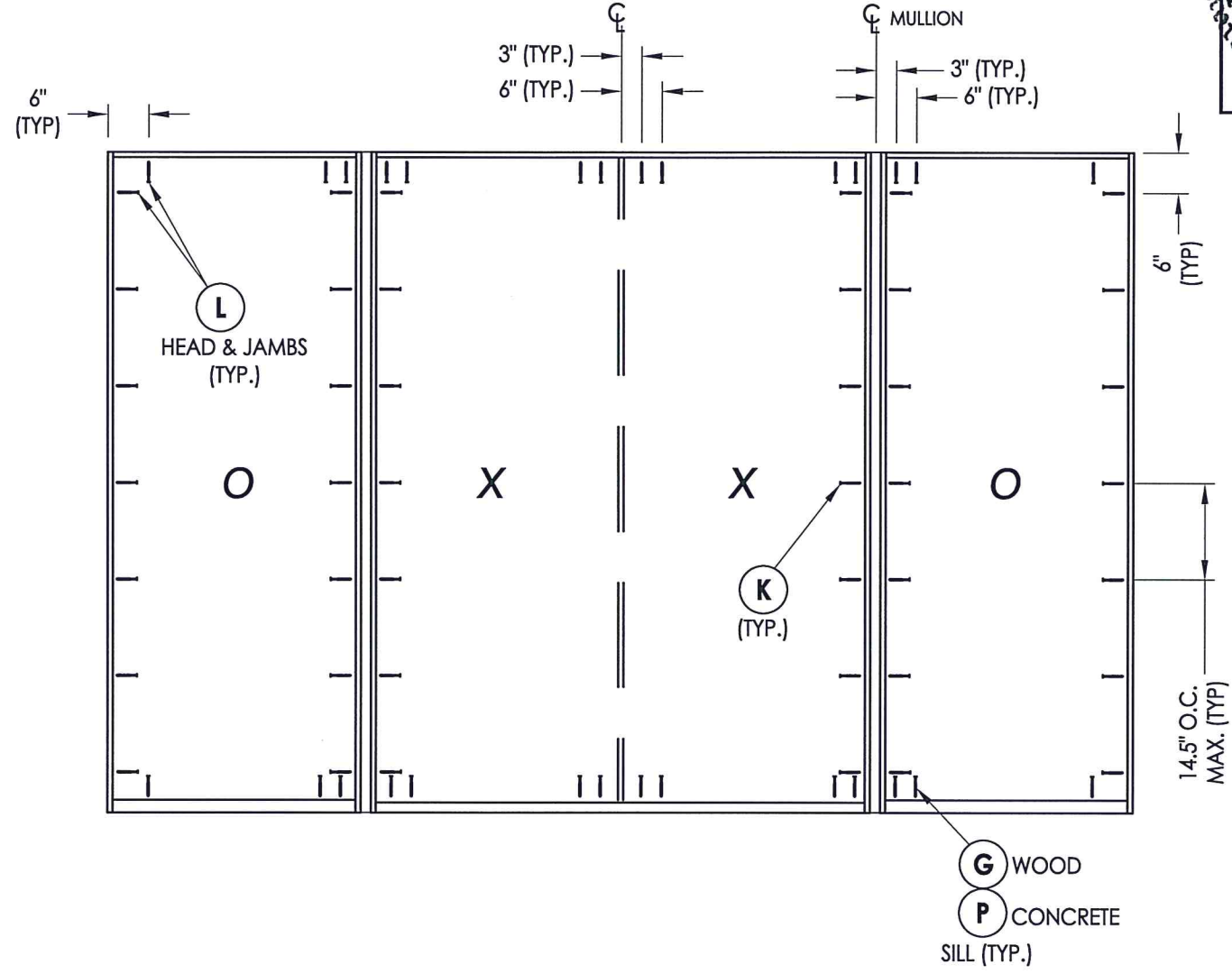
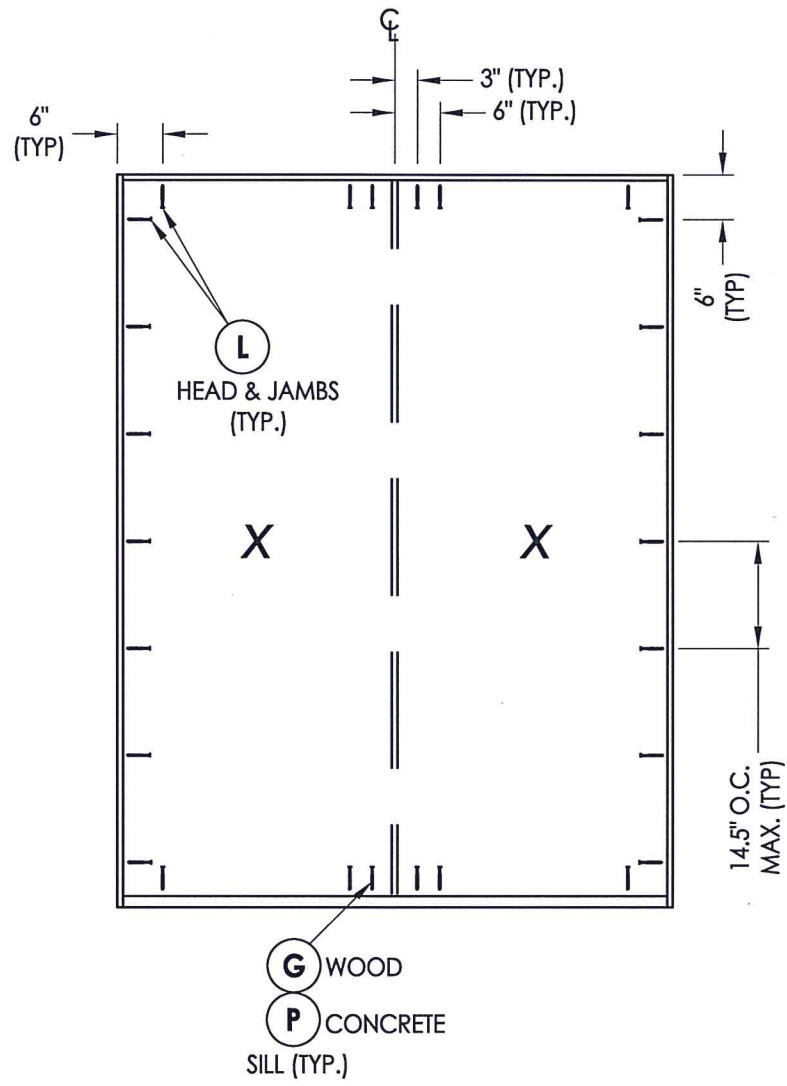

Documents Prepared By: Lyndon F. Schmidt, P.E.  
TEXAS P.E. #104123

**R.W.** BUILDING CONSULTANTS, INC.  
P.O. Box 230 Valrico FL 33595  
Phone No.: 813.659.9197

TEXAS BOARD OF PROFESSIONAL ENGINEERS  
CERTIFICATE OF REGISTRATION # F-11852

PRODUCT: TAYLOR DOOR STEEL DOOR

PART OR ASSEMBLY: FRAME ANCHORING

NO.	DATE	DESCRIPTION	BY
1	7/18/20	UPDATE TO 2018 IBC/IRC CODE	LFS

DATE: 11/3/14

SCALE: N.T.S.

DWG. BY: JK

CHK. BY: LFS

DRAWING NO.: TX-4498

SHEET 7 OF 8

**FRAME ANCHORING**  
2X stud framing  
w/ wood/concrete substrate

BILL OF MATERIALS		
ITEM #	DESCRIPTION	MATERIAL
A	2X FRAMING (SG >= 0.42)	WOOD
C	1/4" MAX. SHIM SPACE	-
F	#7 X 2" PFH DRYWALL SCREW	STEEL
G	#10 X 3" PFH WOOD SCREW (1-1/2" MIN. EMB.)	STEEL
J	#10 X 2-1/2" PFH WOOD SCREW	STEEL
K	#6 X 3" PFH WOOD SCREW	STEEL
L	#10 X 2-1/2" PFH WOOD SCREW (1.15" MIN. EMB.)	STEEL
M	#8 X 2" PH SMS	STEEL
P	1/4" PFH CONCRETE SCREW (1-3/4" MIN. EMB.)	STEEL
Q	3/16" PFH CONCRETE SCREW (1-3/4" MIN. EMB.)	STEEL
1	WOOD JAMB (FINGER-JOINT PINE)	WOOD
5	2X MULLION (SG >= 0.55)	WOOD
6	SWEEP	PVC
7	WEATHERSTRIP	FOAM
9	#10 x 3/4" PFH WOOD SCREW	STEEL
11	4" X 4" HINGE	STEEL
12	LATCH STRIKE PLATE	STEEL
13	DEADBOLT STRIKE PLATE	STEEL
20	INSWING THRESHOLD	ALUM/WOOD
21	INSWING THRESHOLD w/ SIDELITE ADAPTER	ALUM/WOOD
22	OUTSWING THRESHOLD	ALUM/WOOD
23	OUTSWING THRESHOLD	ALUM/WOOD
24	OUTSWING THRESHOLD	ALUM/WOOD
25	OUTSWING THRESHOLD	ALUM
33	ASTRAGAL (DLP)	ALUM
40	DOOR PANEL	-
50	SIDELITE PANEL	-

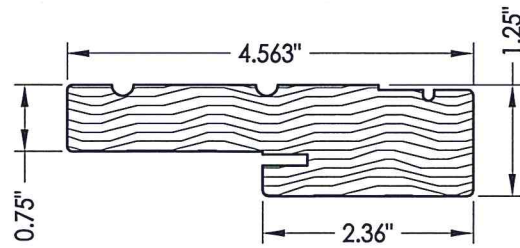

1 WOOD JAMB

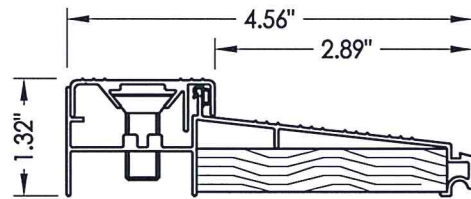

20 INSWING THRESHOLD DLP

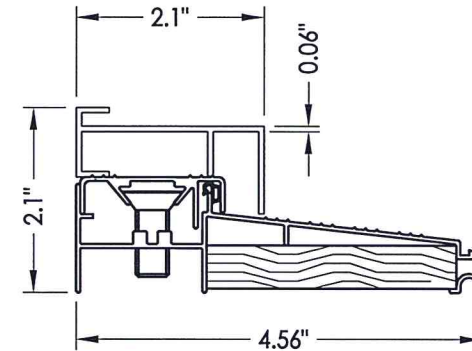

21 INSWING THRESHOLD w/ SIDELITE ADAPTER DLP

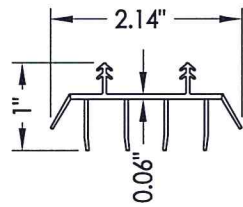

6 SWEEP

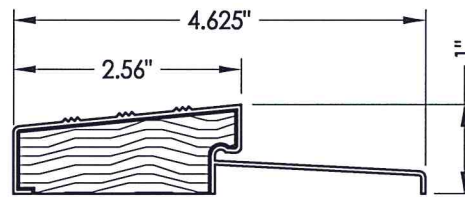

22 OUTSWING THRESHOLD DLP (QOS)

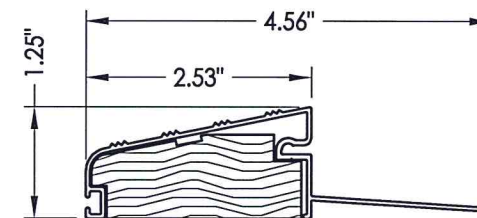

23 OUTSWING THRESHOLD DLP (QOSH)

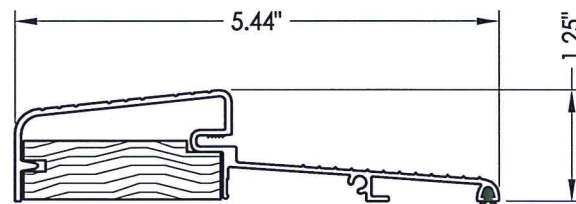

24 OUTSWING THRESHOLD Combo

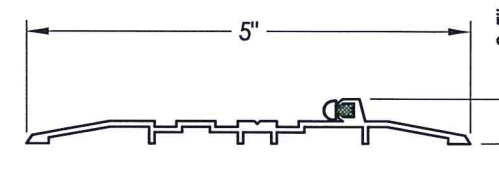

25 OUTSWING THRESHOLD DLP (OSHC)

**CONCRETE ANCHOR NOTES:**

- Concrete anchor locations at the corners may be adjusted to maintain the min. edge distance to mortar joints.
- Concrete anchor locations noted as "MAX. ON CENTER" must be adjusted to maintain the min. edge distance to mortar joints, additional concrete anchors may be required to ensure the "MAX. ON CENTER" dimension are not exceeded.
- Concrete anchor table:

ANCHOR TYPE	ANCHOR SIZE	MIN. EMBEDMENT	MIN. CLEARANCE TO MASONRY EDGE	MIN. CLEARANCE TO ADJACENT ANCHOR
ITW TAPCON®	3/16"	1-3/4"	3"	1-1/2"
DeWALT ULTRACON®	1/4"	1-3/4"	1-1/2"	4"
	1/4"	1-3/4"	1"	4"

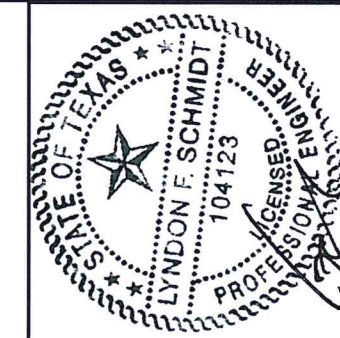

Documents Prepared By: Lyndon F. Schmidt, P.E.  
TEXAS P.E. #104123

RW BUILDING CONSULTANTS, INC.  
P.O. Box 230 Valrico FL, 33595  
Phone No.: 813.659.9197

TEXAS BOARD OF PROFESSIONAL ENGINEERS  
CERTIFICATE OF REGISTRATION # F-11852

PRODUCT: TAYLOR DOOR STEEL DOOR  
PART OR ASSEMBLY: BILL OF MATERIALS & COMPONENTS

NO.	DATE	DESCRIPTION	LFS	BY
1	7/18/20	UPDATE TO 2018 IBC/IRC CODE		

DATE: 11/3/14  
SCALE: N.T.S.  
DWG. BY: JK  
CHK. BY: LFS  
DRAWING NO.: TX-4498

SHEET 8 OF 8