

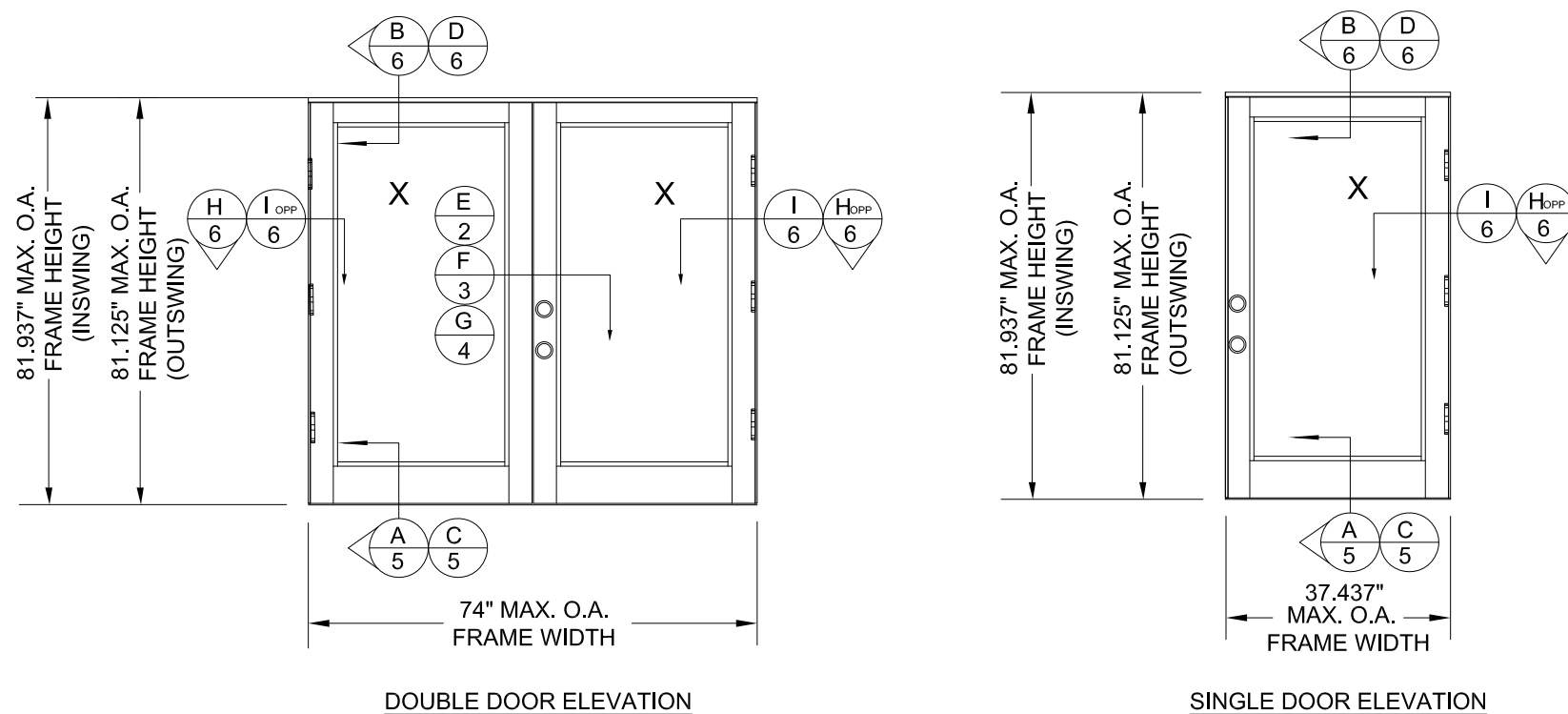

PLASTPRO GLAZED 6'-8" FIBERGLASS DOOR XX AND X, INSWING / OUTSWING IMPACT

REVISIONS			
REV	DESCRIPTION	DATE	APPROVED
C	REVISED PER NEW CODE	11/10/2021	R.L.



GENERAL NOTES:

1. THIS PRODUCT HAS BEEN EVALUATED AND IS IN COMPLIANCE WITH THE 2018 IBC AND 2018 IRC.
2. PRODUCT ANCHORS SHALL BE AS LISTED AND SPACED AS SHOWN ON DETAILS. ANCHOR EMBEDMENT TO BASE MATERIAL SHALL BE BEYOND WALL DRESSING.
3. INSTALLATION DETAILS DESCRIBED HEREIN ARE GENERIC AND MAY NOT REFLECT ACTUAL CONDITIONS FOR A SPECIFIC SITE. IF INSTALLATION METHODS DEVIATE FROM THESE APPROVED DETAILS FURTHER INVESTIGATION BY A LICENSED REGISTERED DESIGN PROFESSIONAL IS REQUIRED.
4. ADEQUACY OF EXISTING STRUCTURAL CONCRETE / MASONRY AND 2X FRAMING PER INSTALLATION AS A MAIN WIND FORCE RESISTING SYSTEM CAPABLE OF WITHSTANDING AND TRANSFERRING APPLIED PRODUCT LOADS TO FOUNDATION IS RESPONSIBILITY OF ENGINEER OR ARCHITECT OF RECORD.
5. THIS PRODUCT IS IMPACT RATED AND DOES NOT REQUIRE IMPACT PROTECTION IN WIND BORNE DEBRIS REGIONS.
6. 1X BUCK OVER MASONRY/CONCRETE IS OPTIONAL. WHERE 1X BUCK IS NOT USED DISSIMILAR MATERIALS MUST BE SEPARATED WITH APPROVED COATING OR MEMBRANE. SELECTION OF COATING OR MEMBRANE IS THE RESPONSIBILITY OF THE ARCHITECT OR ENGINEER OF RECORD.
7. APPROVED CONFIGURATIONS: X, XX

Configuration		Frame size (in)	Design pressure rating (psf)		Impact rating
In-swing	XX	74" x 81.937"	+50.0	-50.0	Large and
Out-swing	XX	74" x 81.125"	+50.0	-50.0	
In-swing	X	37.43" x 81.937"	+50.0	-50.0	Small
Out-swing	X	37.43" x 81.125"	+50.0	-50.0	Missile

Plastro fiberglass insert glazed panels SMC 0.140" skin
Refer to sheets 2, 3 & 4 for all hardware options
Refer to sheet 5 for impact glazing insert options

TABLE OF CONTENTS	
SHEET	SHEET DESCRIPTION
1	ELEVATION AND GENERAL NOTES
2 - 4	ASTRAGAL & LOCK DETAILS
5	SILL AND GLAZING DETAILS
6	VERTICAL & HORIZONTAL CROSS SECTIONS
7 - 8	ANCHOR ELEVATIONS AND NOTES
9	COMPONENTS AND BILL OF MATERIALS

ENDURA PRODUCTS, INC.
8817 WEST MARKET STREET
COLFAX, NC 27235

PLASTPRO GLAZED
FIBERGLASS DOORS
ELEVATIONS AND NOTES

DRAWN: RM	DWG. NO. NL-0015	REV C
SCALE NTS	DATE 07/30/13	SHEET 1 OF 9

L. ROBERTO LOMAS P.E.
1432 WOODFORD RD LEWISVILLE, NC 27023
434-688-0609 rllomas@rlomaspe.com

SIGNED: 11/10/2021



Luis R. Lomas P.E.
TX No.: 101889

REVISIONS			
REV	DESCRIPTION	DATE	APPROVED
C	REVISED PER NEW CODE	11/10/2021	R.L.

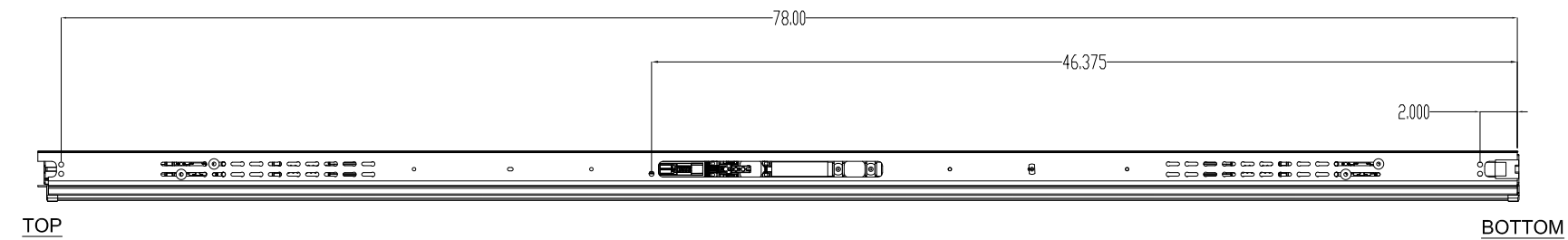
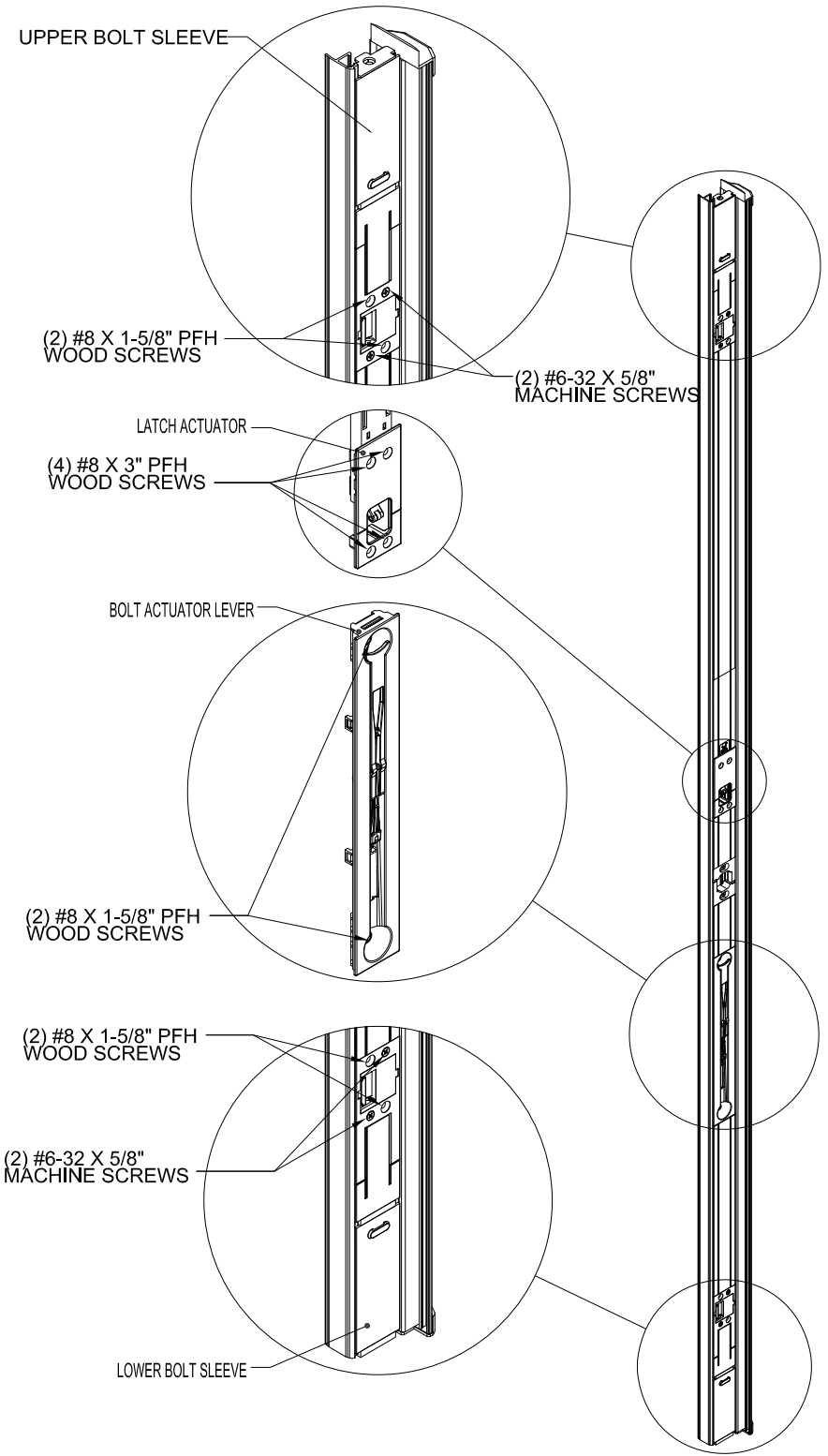

ANCHOR SCREW LOCATIONS

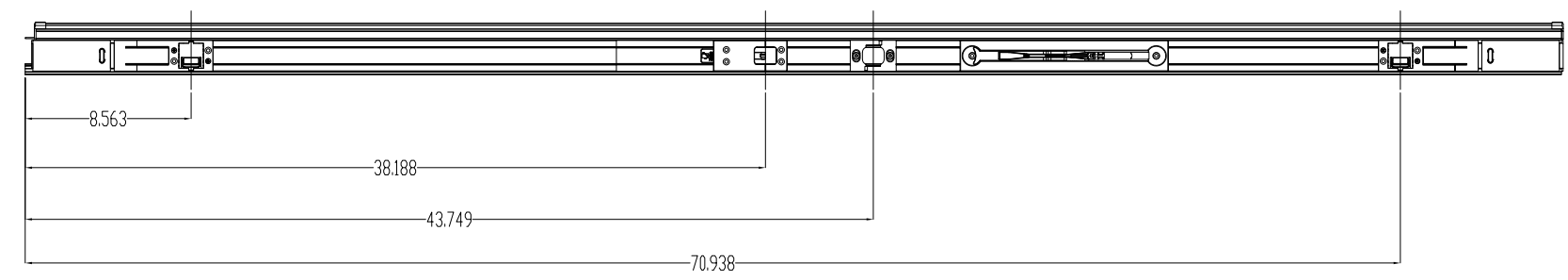

HARDWARE LOCATIONS

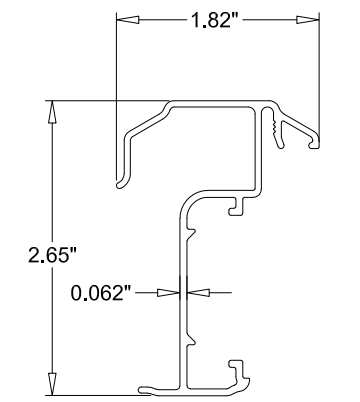
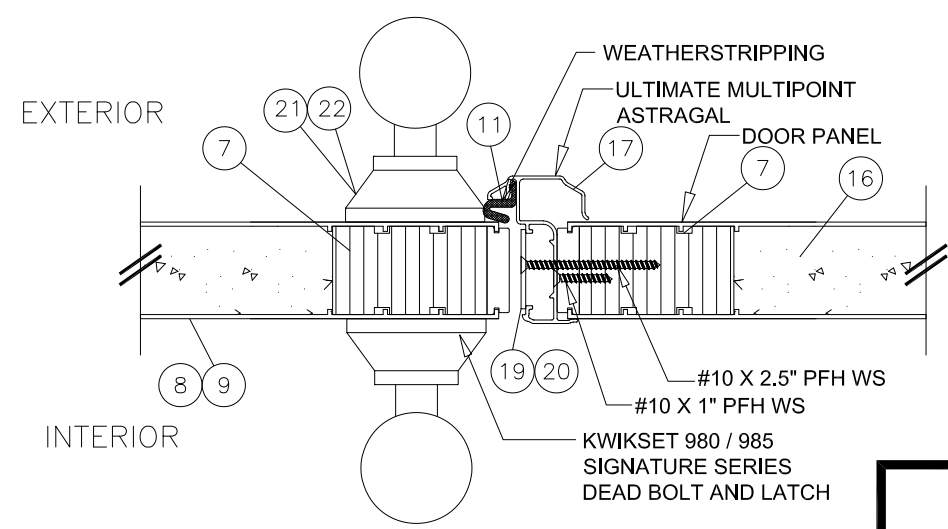

ASTRAGAL SECTION

(E) ASTRAGAL SECTION
(2) INSWING SHOWN-OUTSWING SIMILAR

ULTIMATE MULTIPOINT ASTRAGAL

ENDURA PRODUCTS, INC.
8817 WEST MARKET STREET
COLFAX, NC 27235

PLASPRO GLAZED
FIBERGLASS DOORS
ASTRAGAL AND LOCK DETAILS

DRAWN: RM	DWG NO. NL-0015	REV C
SCALE NTS	DATE 07/30/13	SHEET 2 OF 9

L. ROBERTO LOMAS P.E.
1432 WOODFORD RD LEWISVILLE, NC 27023
434-688-0609 rllomas@rlomaspe.com

SIGNED: 11/10/2021



Luis R. Lomas P.E.
TX No.: 101889

REVISIONS			
REV	DESCRIPTION	DATE	APPROVED
C	REVISED PER NEW CODE	11/10/2021	R.L.

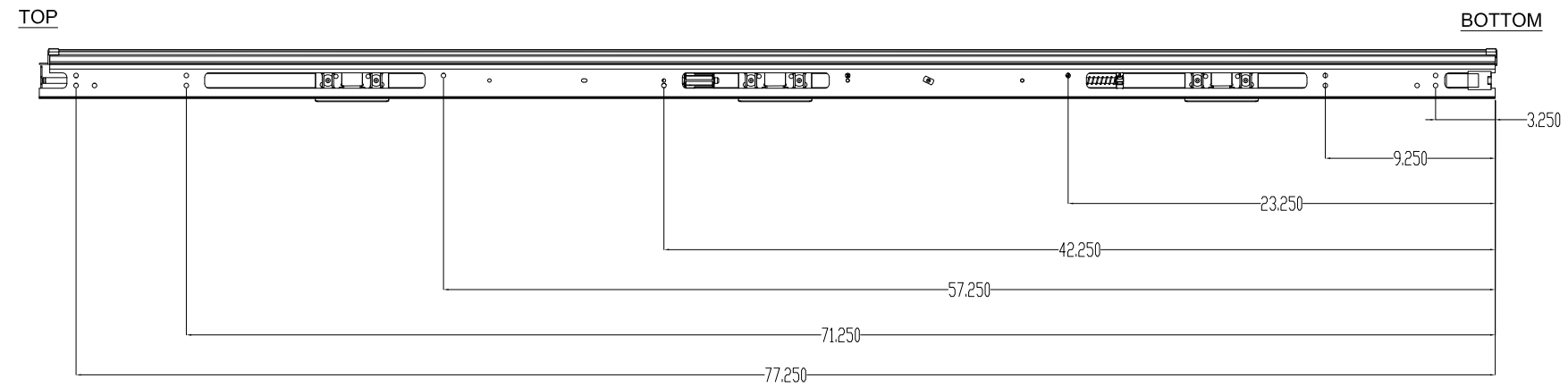

ANCHOR SCREW LOCATIONS

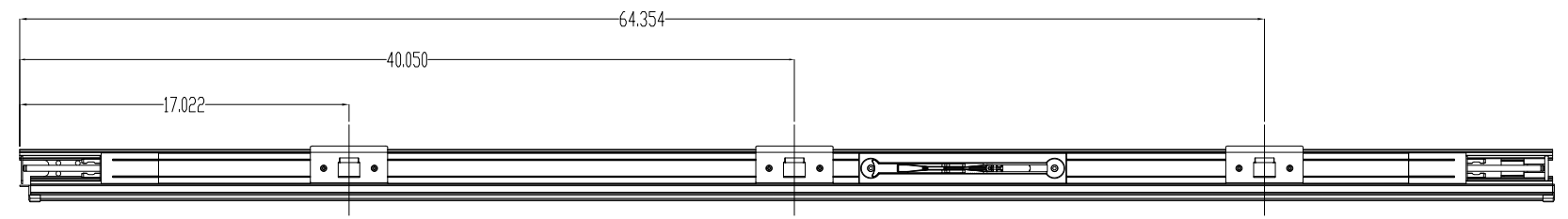

HARDWARE LOCATIONS

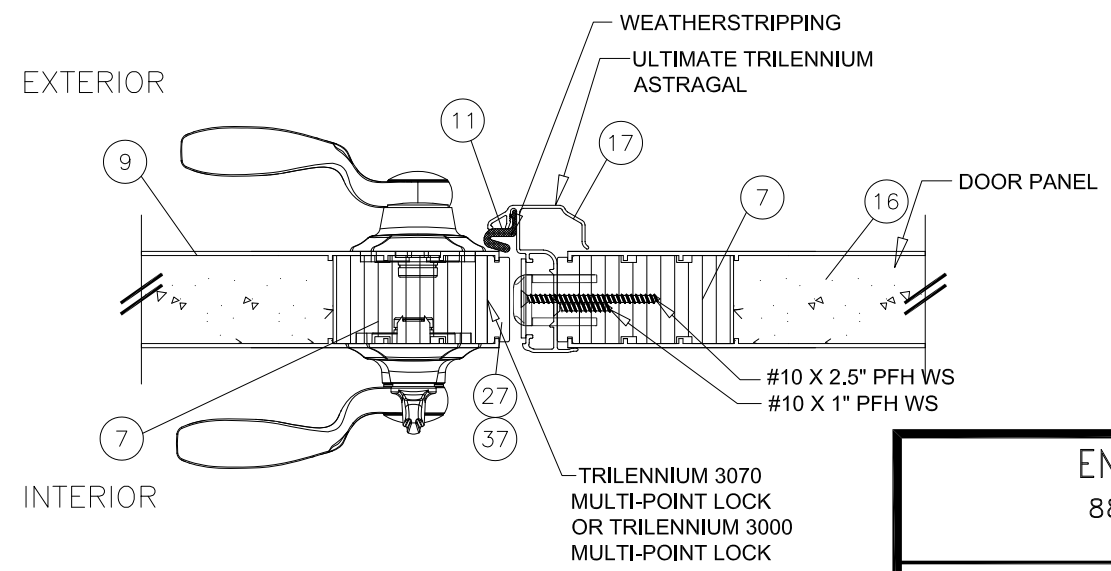

ASTRAGAL SECTION

F
3 ASTRAGAL SECTION
INSWING SHOWN-OUTSWING SIMILAR

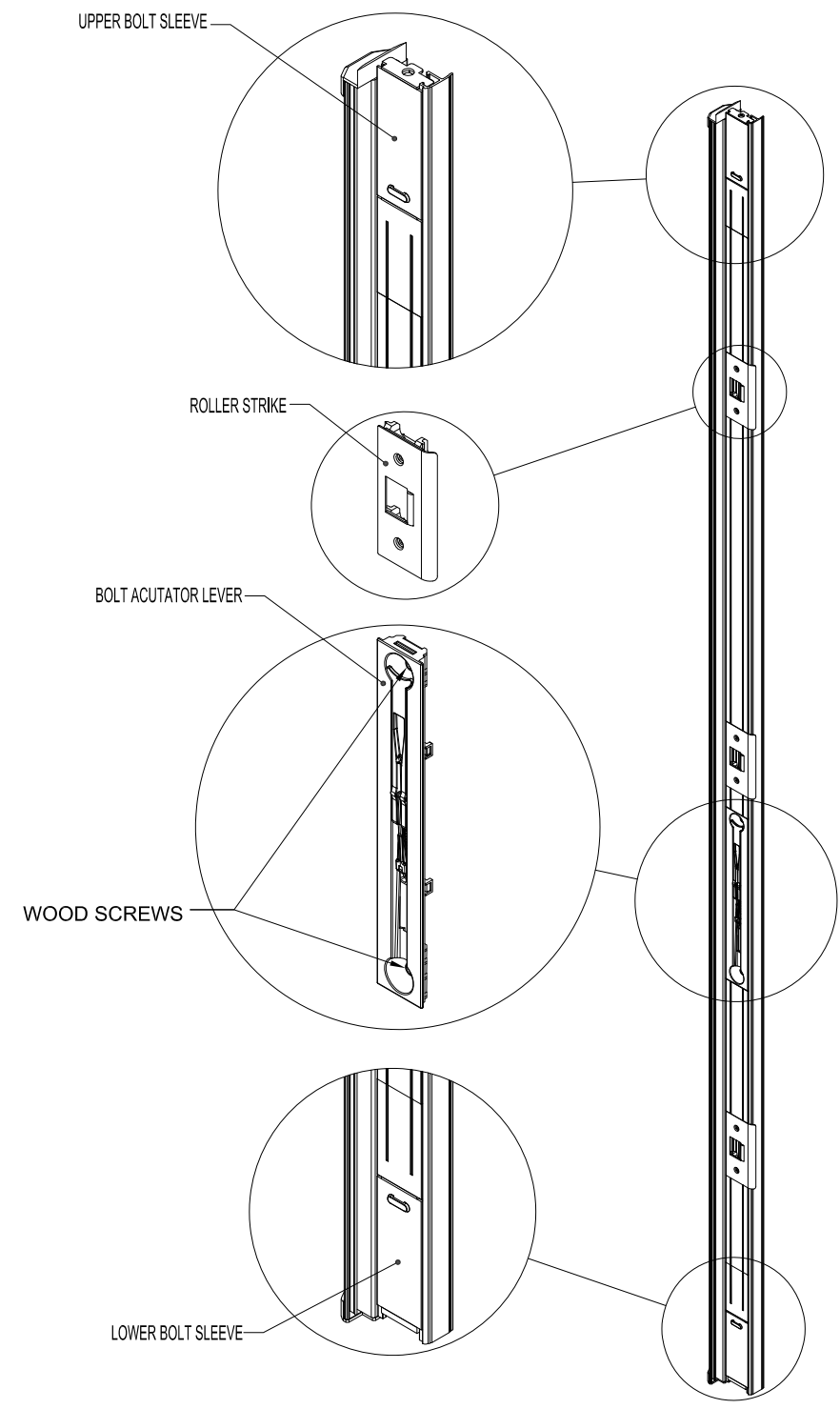

ULTIMATE TRILENNIUM ASTRAGAL

SIGNED: 11/10/2021

ENDURA PRODUCTS, INC.
8817 WEST MARKET STREET
COLFAX, NC 27235

PLASPRO GLAZED
FIBERGLASS DOORS
ASTRAGAL AND LOCK SET DETAILS

DRAWN: RM	DWG NO. NL-0015	REV C
SCALE NTS	DATE 07/30/13	SHEET 3 OF 9

L. ROBERTO LOMAS P.E.
1432 WOODFORD RD LEWISVILLE, NC 27023
434-688-0609 rllomas@lrlomaspe.com



Luis R. Lomas P.E.
TX No.: 101889

REVISIONS			
REV	DESCRIPTION	DATE	APPROVED
C	REVISED PER NEW CODE	11/10/2021	R.L.

TOP

BOTTOM

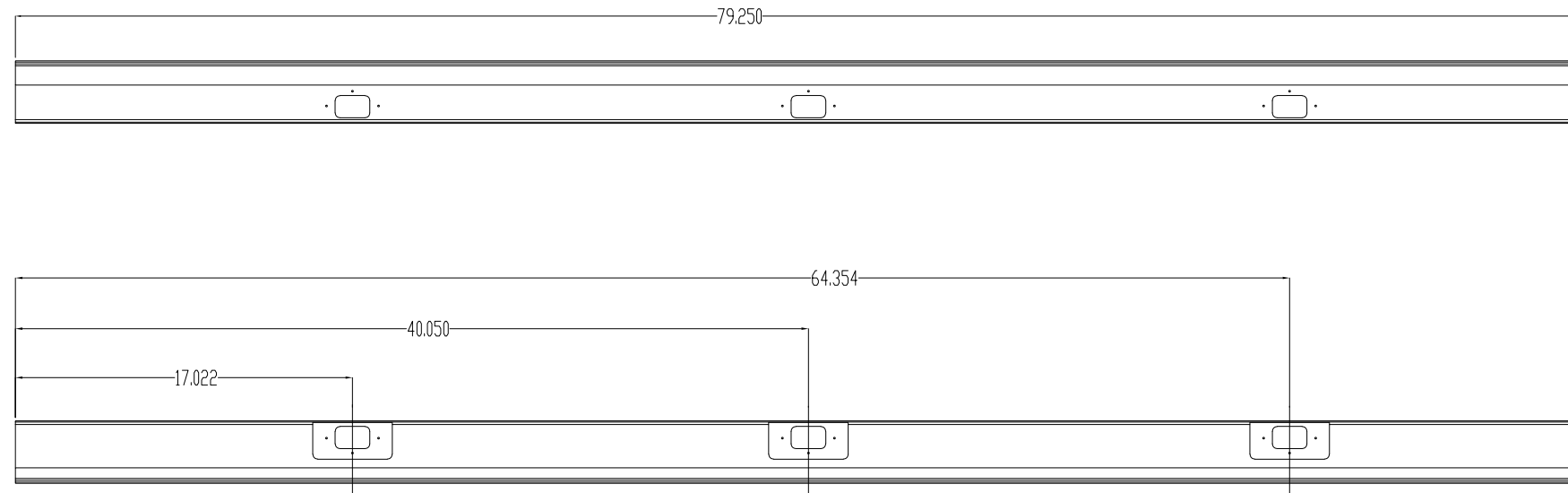

HARDWARE LOCATIONS

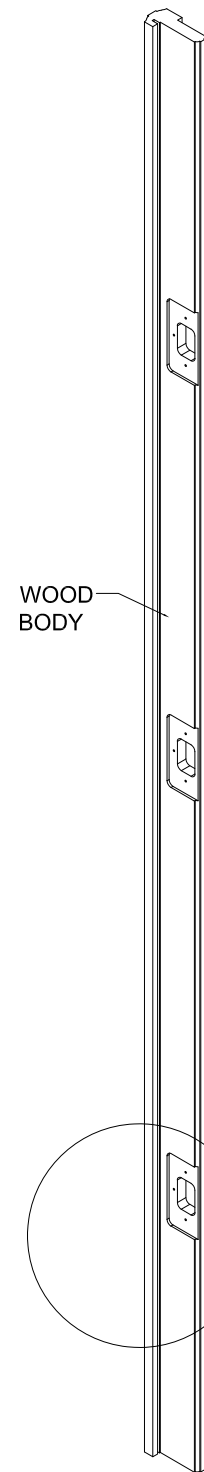

WOOD BODY

ROLLER STRIKE

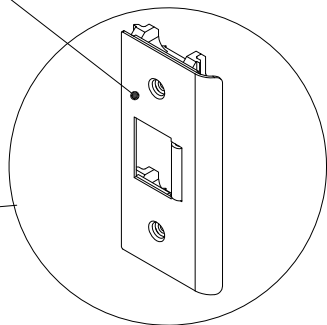

WOOD ASTRAGAL

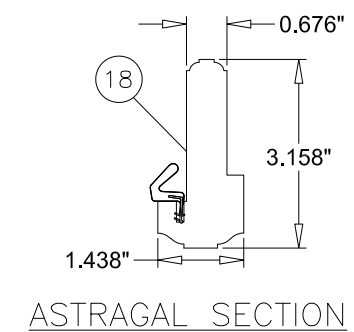
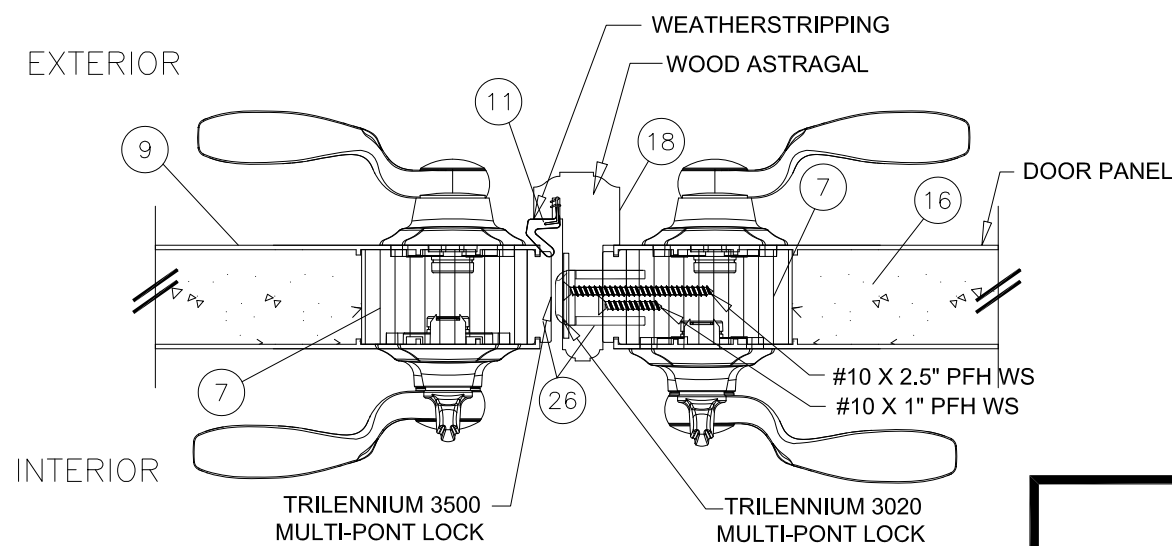

ASTRAGAL SECTION

(G)
4 ASTRAGAL SECTION
INSWING SHOWN-OUTSWING SIMILAR

SIGNED: 11/10/2021

ENDURA PRODUCTS, INC.
8817 WEST MARKET STREET
COLFAX, NC 27235

PLASPRO GLAZED
FIBERGLASS DOORS
ASTRAGAL AND LOCK SET DETAILS

DRAWN: RM	DWG NO. NL-0015	REV C
SCALE NTS	DATE 07/30/13	SHEET 4 OF 9

L. ROBERTO LOMAS P.E.
1432 WOODFORD RD LEWISVILLE, NC 27023
434-688-0609 rllomas@lrlomaspe.com



Luis R. Lomas P.E.
TX No.: 101889

REVISIONS			
REV	DESCRIPTION	DATE	APPROVED
C	REVISED PER NEW CODE	11/10/2021	R.L.

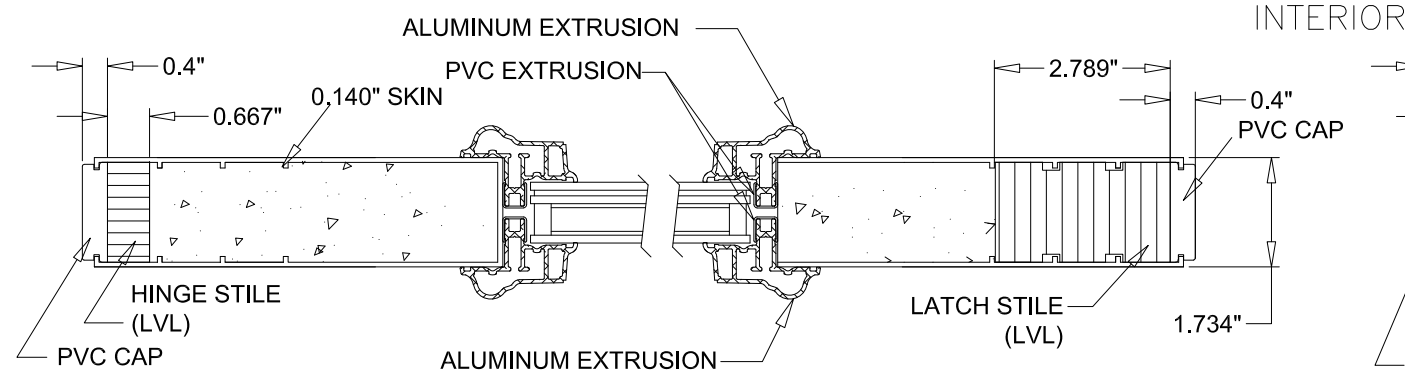

J
5 HORIZONTAL CROSS SECTION
ODL SEVERE WEATHER
GLAZING INSERT OPTION

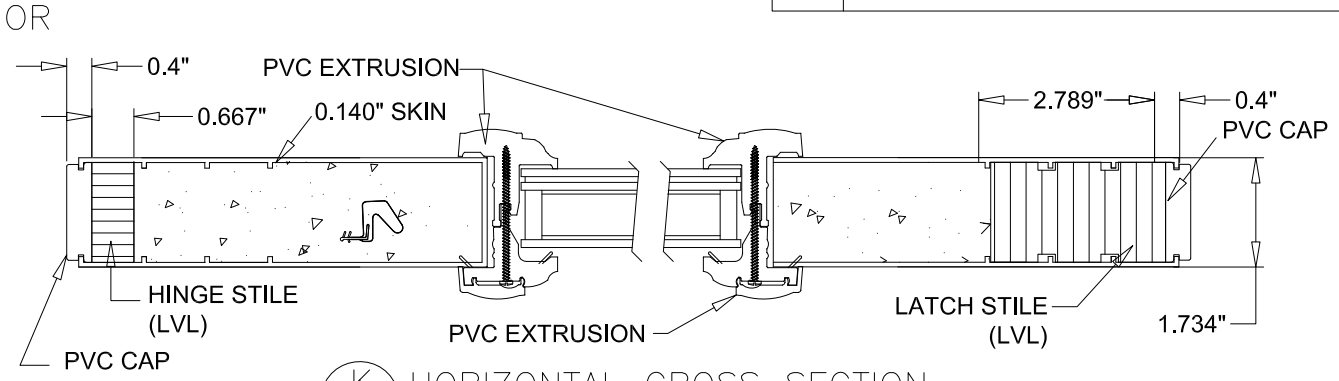

K
5 HORIZONTAL CROSS SECTION
RSL HURRICANE IMPACT
GLAZING INSERT OPTION

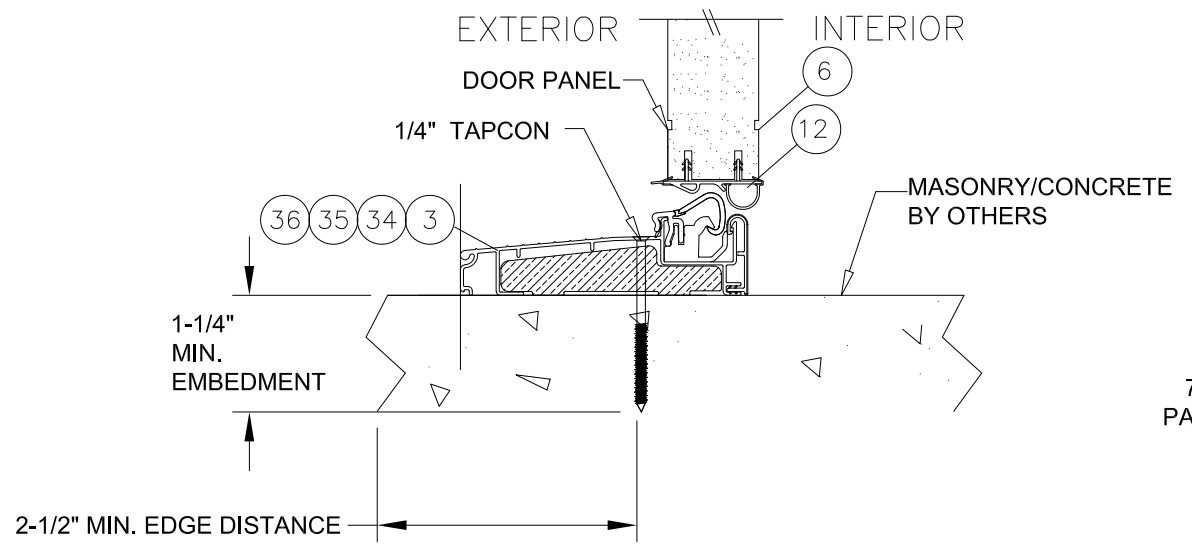

C
5 VERTICAL CROSS SECTION
IN-SWING "Z" SERIES SILL (ZACL4565)

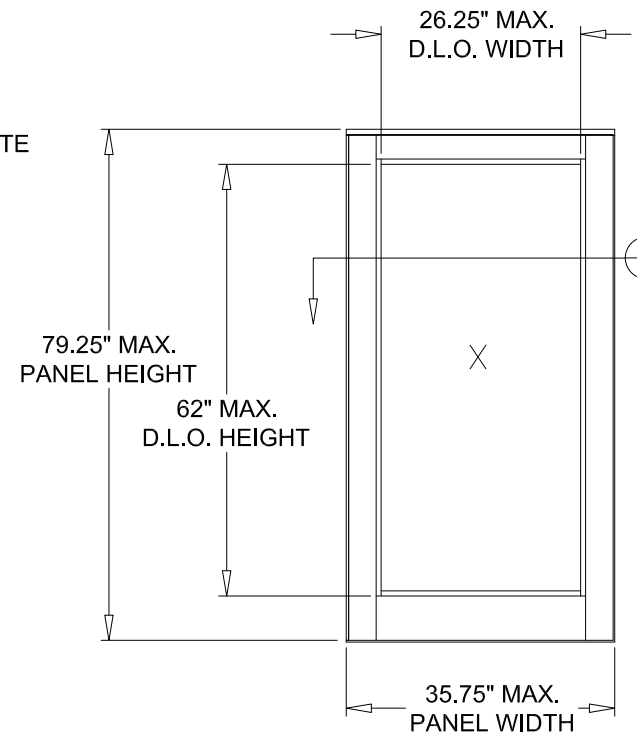

PLASTPRO
INSERT GLAZED
FIBERGLASS

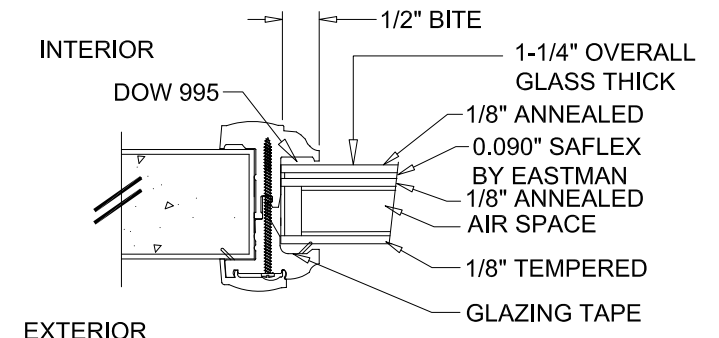

RSL GLAZING DETAIL
ALUMINUM SPACER

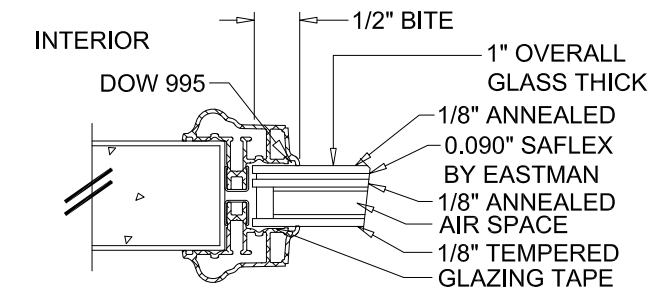

ODL GLAZING DETAIL
ALUMINUM SPACER

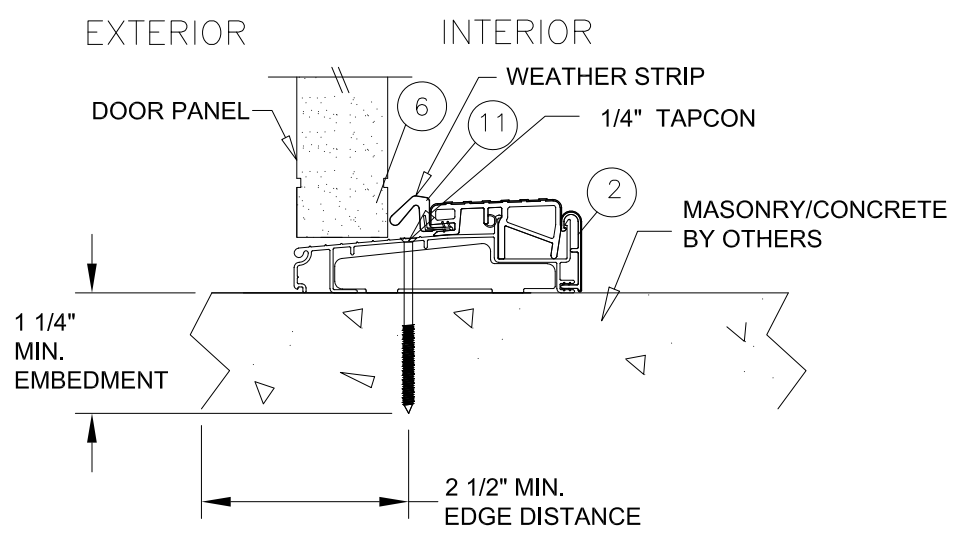

SIGNED: 11/10/2021

ENDURA PRODUCTS, INC.
8817 WEST MARKET STREET
COLFAX, NC 27235

PLASTPRO GLAZED
FIBERGLASS DOORS
GLAZING INSERT AND SILL DETAILS

DRAWN: RM	DWG NO. NL-0015	REV C
SCALE NTS	DATE 07/30/13	SHEET 5 OF 9

L. ROBERTO LOMAS P.E.
1432 WOODFORD RD LEWISVILLE, NC 27023
434-688-0609 rllomas@rlomaspe.com



Luis R. Lomas P.E.
TX No.: 101889

REVISIONS			
REV	DESCRIPTION	DATE	APPROVED
C	REVISED PER NEW CODE	11/10/2021	R.L.

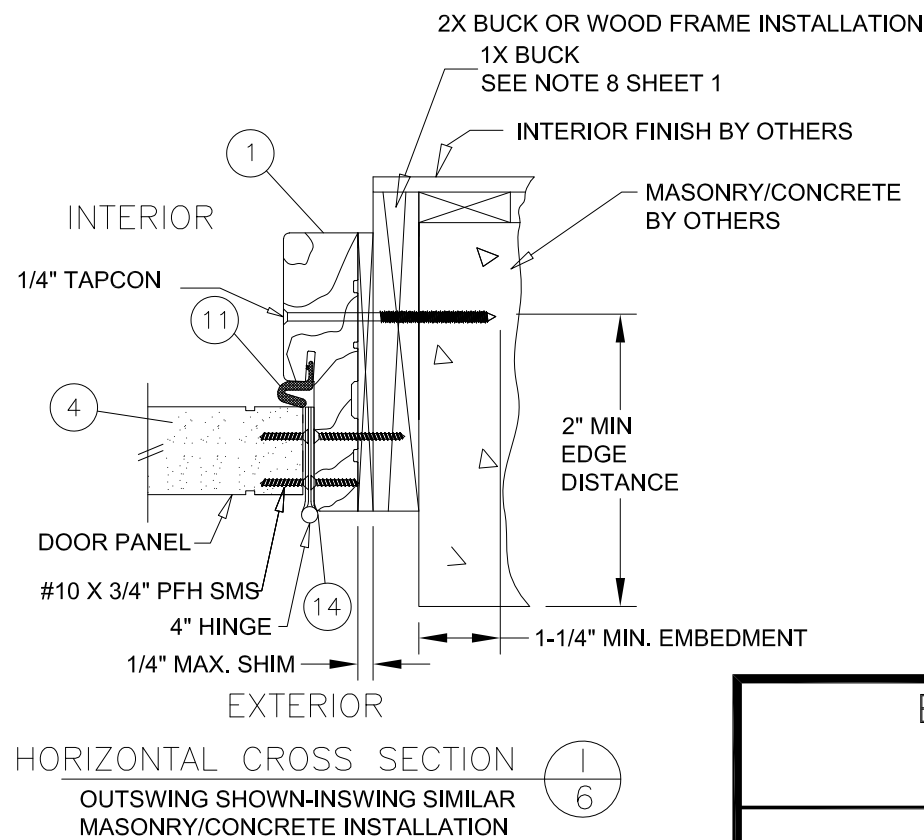
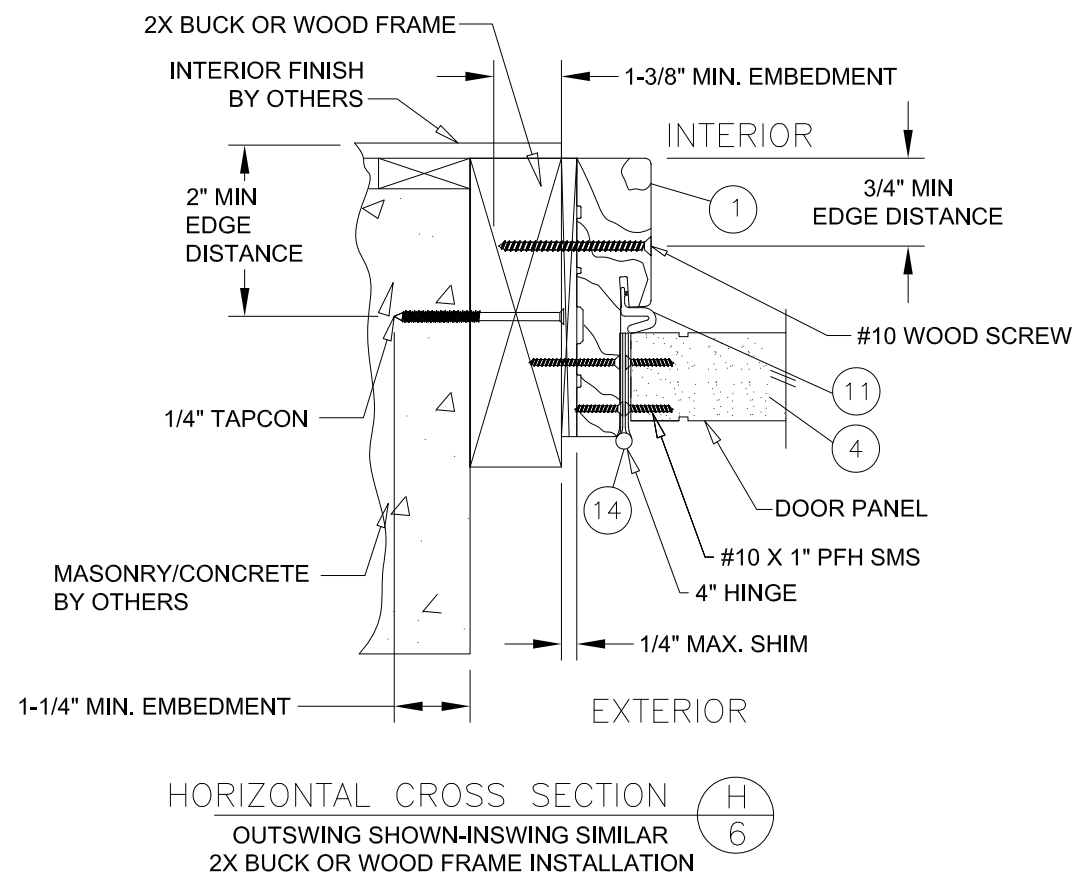
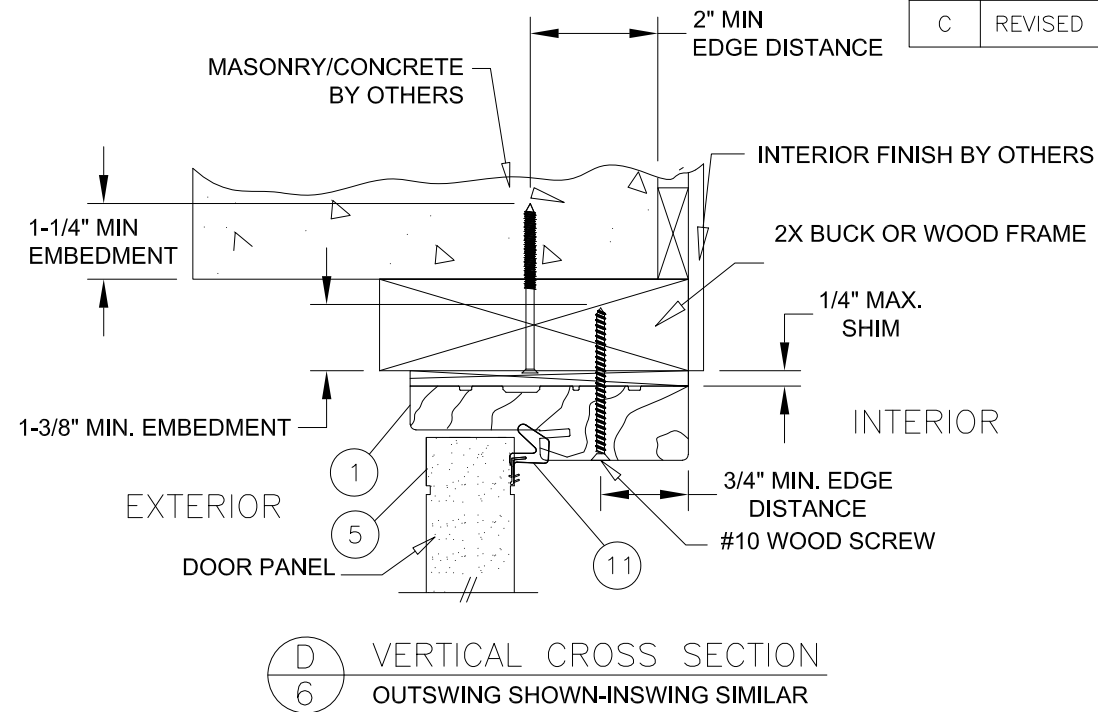
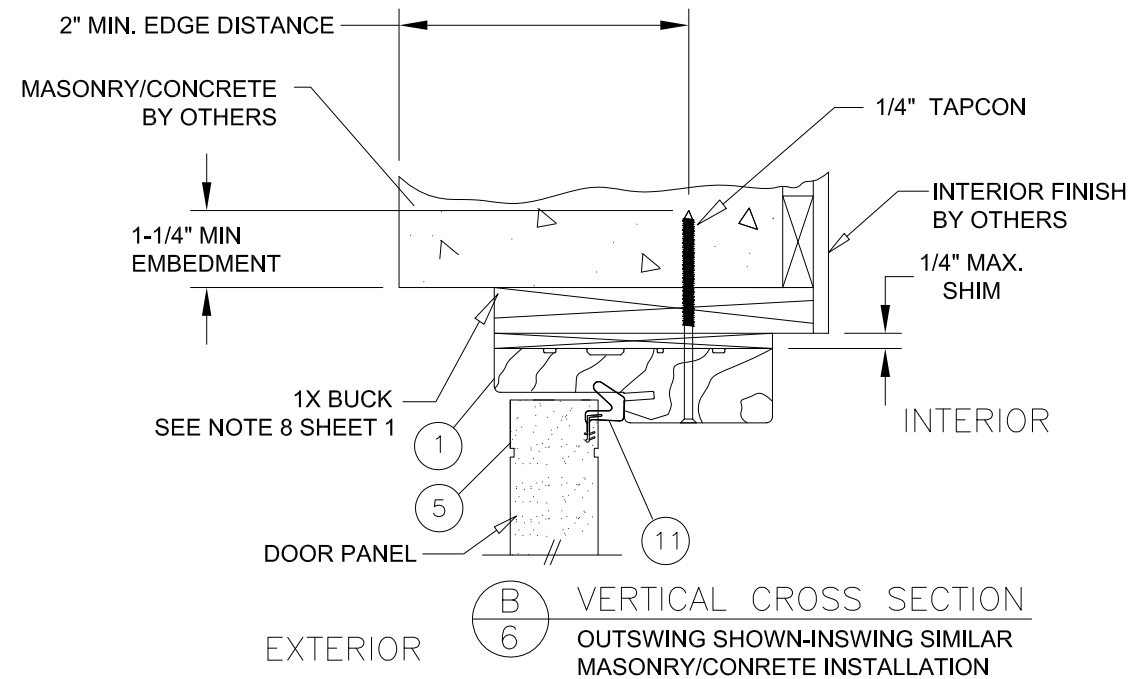

ENDURA PRODUCTS, INC.
8817 WEST MARKET STREET
COLFAX, NC 27235

PLASPRO GLAZED
FIBERGLASS DOORS
DOOR CROSS SECTIONS

DRAWN: RM	DWG NO. NL-0015	REV C
SCALE NTS	DATE 07/30/13	SHEET 6 OF 9

L. ROBERTO LOMAS P.E.
1432 WOODFORD RD LEWISVILLE, NC 27023
434-688-0609 rllomas@rlomaspe.com

SIGNED: 11/10/2021



Luis R. Lomas P.E.
TX No.: 101889

REVISIONS			
REV	DESCRIPTION	DATE	APPROVED
C	REVISED PER NEW CODE	11/10/2021	R.L.

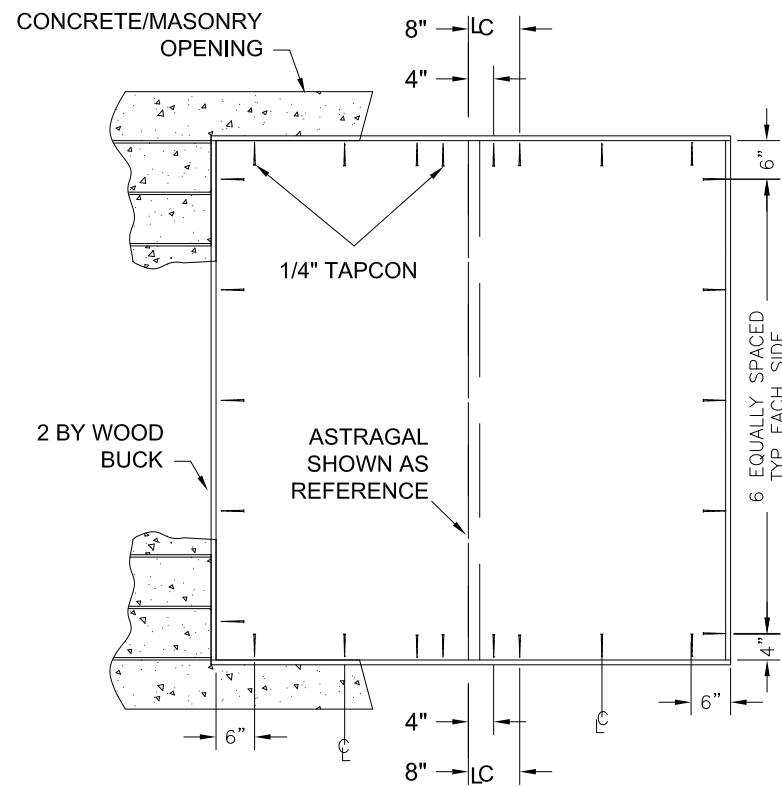

**WOOD BUCK TO
SUBSTRATE ANCHORING
XX**

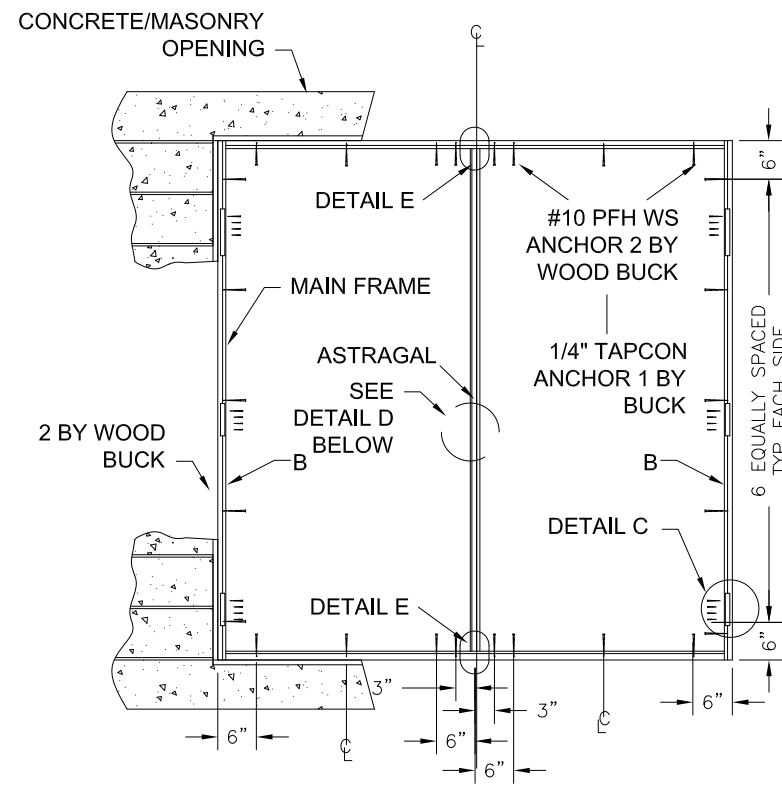

**MAIN FRAME TO
BUCK ANCHORING
XX**

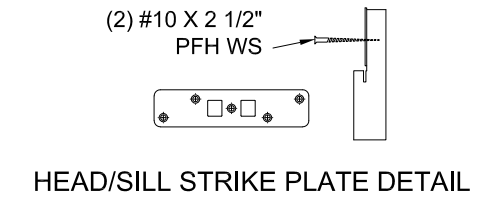
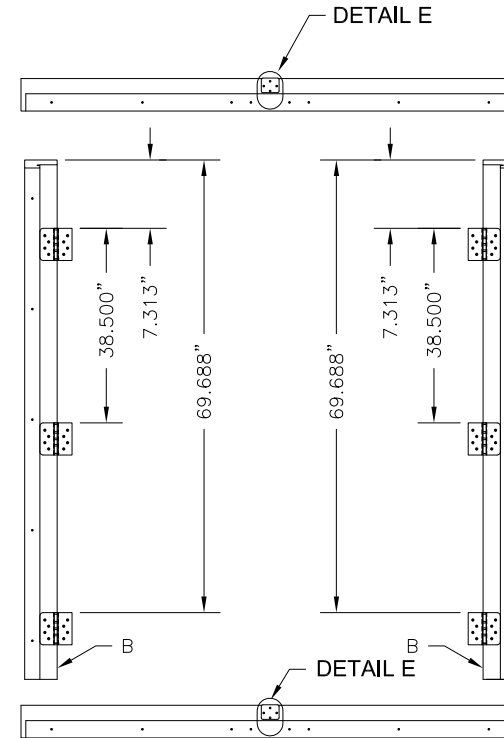

HEAD/SILL STRIKE PLATE DETAIL
3500 / 3020 TRILEMMIUM
ATTACH LOCK THROW BOLT
STRIKE PLATE TO FRAME
AS SHOWN.

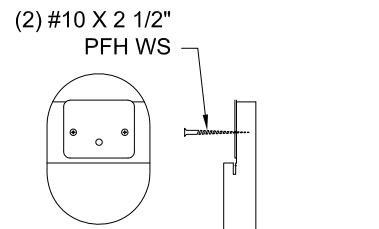

HEAD STRIKE PLATE DETAIL
ULTIMATE MPA ASTRAGAL
ATTACH ASTRAGAL THROW BOLT
STRIKE PLATE TO FRAME
AS SHOWN.

INSTALLATION NOTES:

- ONE (1) INSTALLATION ANCHOR IS REQUIRED AT EACH ANCHOR LOCATION SHOWN.
- NUMBER OF INSTALLATION ANCHORS DEPICTED IS THE MINIMUM NUMBER OF ANCHORS TO BE USED FOR PRODUCT INSTALLATION. ANCHORS MUST MATCH TYPE, SIZE, AND EMBEDMENT OF THOSE SHOWN HEREIN FOR RESPECTIVE SUBSTRATE.
- SHIM AS REQUIRED AT EACH INSTALLATION ANCHOR WITH LOAD BEARING SHIM(S). MAXIMUM ALLOWABLE SHIM SIZE IS 1/4 INCH. SHIM WHERE SPACE OF 1/8 INCH OR GREATER OCCURS. SHIM(S) SHALL BE CONSTRUCTED OF HIGH DENSITY PLASTIC OR BETTER.
- FOR INSTALLATION INTO WOOD FRAMING, USE #10 WOOD SCREWS OF SUFFICIENT LENGTH TO ACHIEVE 1-3/8 INCH MINIMUM EMBEDMENT.
- FOR INSTALLATION THROUGH 1X BUCK TO CONCRETE / MASONRY, OR DIRECTLY INTO CONCRETE / MASONRY, USE 1/4" TAPCON OF SUFFICIENT LENGTH TO ACHIEVE 1-1/4" MINIMUM EMBEDMENT WITH A 2" MINIMUM EDGE DISTANCE.
- ALTERNATE CONCRETE / MASONRY INSTALLATION ANCHORS OF EQUIVALENT PERFORMANCE CHARACTERISTICS CAN BE USED UPON APPROVAL OF ARCHITECT OR ENGINEER OF RECORD.
- MINIMUM EMBEDMENT AND EDGE DISTANCE EXCLUDE WALL FINISHES (INCLUDING BUT NOT LIMITED TO STUCCO, FOAM, BRICK VENEER, AND SIDING).
- INSTALLATION ANCHOR CAPACITIES FOR PRODUCTS HEREIN ARE BASED ON SUBSTRATE MATERIALS WITH THE FOLLOWING PROPERTIES:
 - A. WOOD - MINIMUM SPECIFIC GRAVITY OF 0.42.
 - B. CONCRETE - MINIMUM COMPRESSIVE STRENGTH OF 3192 PSI.
 - C. MASONRY - STRENGTH CONFORMANCE TO ASTM C-90, GRADE N, TYPE 1 (OR GREATER).

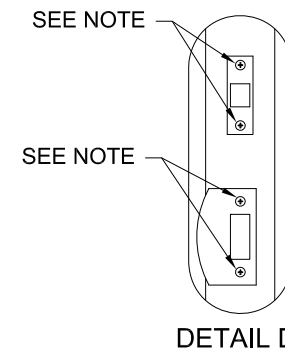

NOTE:
ATTACH STRIKE & DEADBOLT
PLATES TO STRIKE & BUCK
WITH #10 X 2" FH WOOD SCREW
ATTACH STRIKE & DEAD BOLT
PLATES TO ASTRAGAL WITH
#8 X 2 1/2" FH WOOD SCREWS
ATTACH STRIKE TO JAMB &
SIDELITE JAMB WITH #10 X 1 3/4"
FH WOOD SCREW.

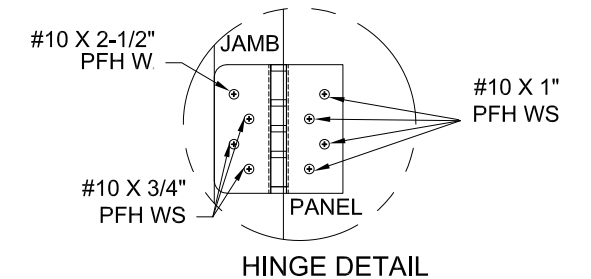

HINGE DETAIL

ENDURA PRODUCTS, INC.
8817 WEST MARKET STREET
COLFAX, NC 27235

PLASPRO GLAZED
FIBERGLASS DOORS
ELEVATION AND ANCHOR LAYOUT

DRAWN: RM	DWG NO. NL-0015	REV C
SCALE NTS	DATE 07/30/13	SHEET 7 OF 9

L. ROBERTO LOMAS P.E.
1432 WOODFORD RD LEWISVILLE, NC 27023
434-688-0609 rllomas@rlomaspe.com

SIGNED: 11/10/2021



Luis R. Lomas P.E.
TX No.: 101889

REVISIONS			
REV	DESCRIPTION	DATE	APPROVED
C	REVISED PER NEW CODE	11/10/2021	R.L.

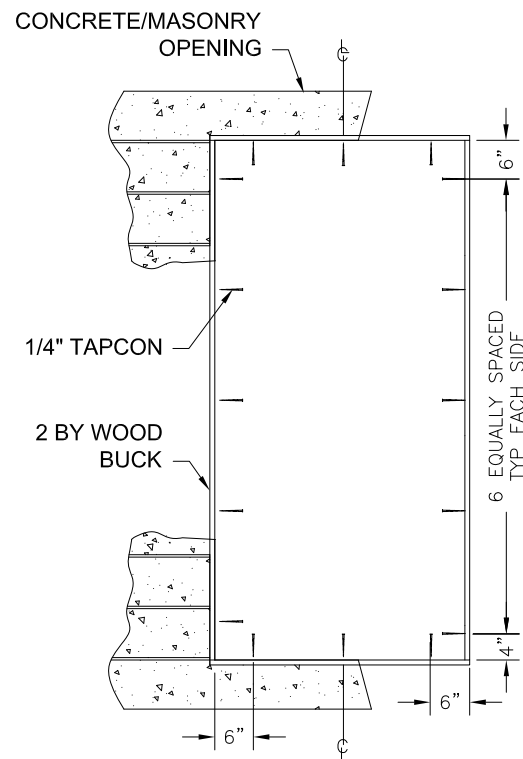

WOOD BUCK TO
SUBSTRATE ANCHORING
X

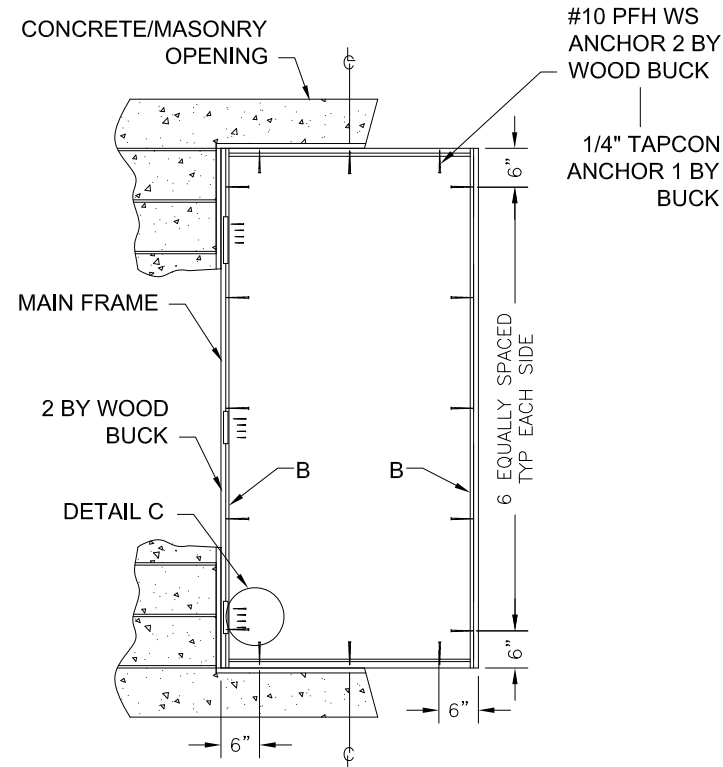

MAIN FRAME TO
BUCK ANCHORING
X

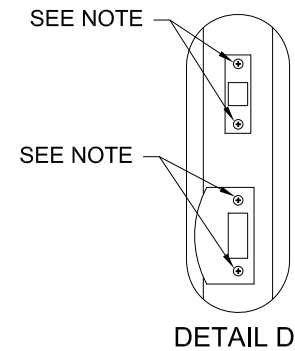
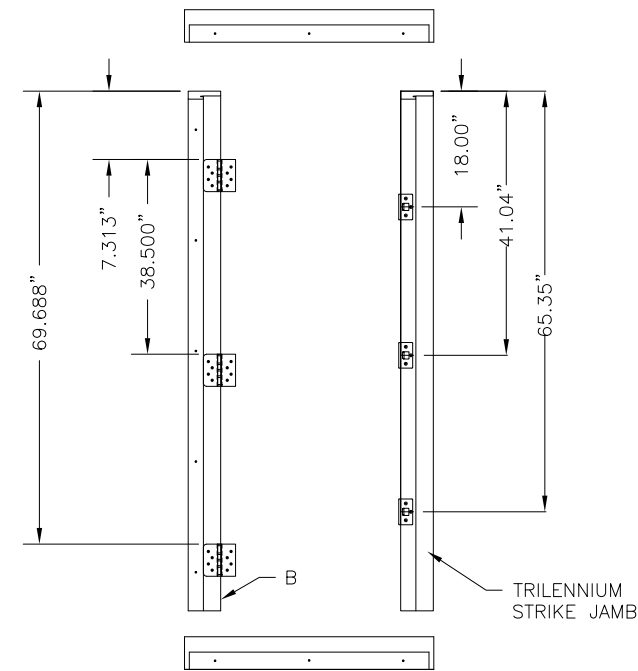

NOTE:
ATTACH STRIKE & DEADBOLT
PLATES TO STRIKE & BUCK
WITH #10 X 2" FH WOOD SCREW
ATTACH STRIKE & DEAD BOLT
PLATES TO ASTRAGAL WITH
#8 X 2 1/2" FH WOOD SCREWS
ATTACH STRIKE TO JAMB &
SIDELITE JAMB WITH #10 X 1 3/4"
FH WOOD SCREW.

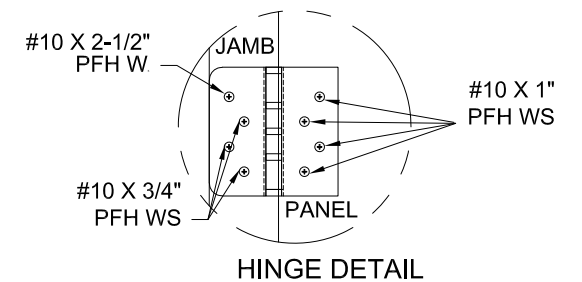

INSTALLATION NOTES:

- ONE (1) INSTALLATION ANCHOR IS REQUIRED AT EACH ANCHOR LOCATION SHOWN.
- NUMBER OF INSTALLATION ANCHORS DEPICTED IS THE MINIMUM NUMBER OF ANCHORS TO BE USED FOR PRODUCT INSTALLATION. ANCHORS MUST MATCH TYPE, SIZE, AND EMBEDMENT OF THOSE SHOWN HEREIN FOR RESPECTIVE SUBSTRATE.
- SHIM AS REQUIRED AT EACH INSTALLATION ANCHOR WITH LOAD BEARING SHIM(S). MAXIMUM ALLOWABLE SHIM SIZE IS 1/4 INCH. SHIM WHERE SPACE OF 1/8 INCH OR GREATER OCCURS. SHIM(S) SHALL BE CONSTRUCTED OF HIGH DENSITY PLASTIC OR BETTER.
- FOR INSTALLATION INTO WOOD FRAMING, USE #10 WOOD SCREWS OF SUFFICIENT LENGTH TO ACHIEVE 1-3/8 INCH MINIMUM EMBEDMENT.
- FOR INSTALLATION THROUGH 1X BUCK TO CONCRETE / MASONRY, OR DIRECTLY INTO CONCRETE / MASONRY, USE 1/4" TAPCON OF SUFFICIENT LENGTH TO ACHIEVE 1-1/4" MINIMUM EMBEDMENT WITH A 2" MINIMUM EDGE DISTANCE.
- ALTERNATE CONCRETE / MASONRY INSTALLATION ANCHORS OF EQUIVALENT PERFORMANCE CHARACTERISTICS CAN BE USED UPON APPROVAL OF ARCHITECT OR ENGINEER OF RECORD.
- MINIMUM EMBEDMENT AND EDGE DISTANCE EXCLUDE WALL FINISHES (INCLUDING BUT NOT LIMITED TO STUCCO, FOAM, BRICK VENEER, AND SIDING).
- INSTALLATION ANCHOR CAPACITIES FOR PRODUCTS HEREIN ARE BASED ON SUBSTRATE MATERIALS WITH THE FOLLOWING PROPERTIES:
 - A. WOOD - MINIMUM SPECIFIC GRAVITY OF 0.42.
 - B. CONCRETE - MINIMUM COMPRESSIVE STRENGTH OF 3192 PSI.
 - C. MASONRY - STRENGTH CONFORMANCE TO ASTM C-90, GRADE N, TYPE 1 (OR GREATER).

ENDURA PRODUCTS, INC.

8817 WEST MARKET STREET
COLFAX, NC 27235

PLASPRO GLAZED
FIBERGLASS DOORS
ELEVATION AND ANCHOR LAYOUT

DRAWN: RM	DWG NO. NL-0015	REV C
SCALE NTS	DATE 07/30/13	SHEET 8 OF 9

L. ROBERTO LOMAS P.E.
1432 WOODFORD RD LEWISVILLE, NC 27023
434-688-0609 rllomas@rlomaspe.com

SIGNED: 11/10/2021



Luis R. Lomas P.E.
TX No.: 101889

BILL OF MATERIAL			
ITEM #	DESCRIPTION	QTY.	MATERIAL
1	HEAD / JAMB		
2	OUTSWING BUMP THRESHOLD ZOBL4565		
3	INSWING ADJUSTABLE THRESHOLD ZACLA4565		
4	DOOR STILE - CORE MATERIAL WOOD OR LVL		
5	DOOR TOP RAIL		
6	DOOR BOTTOM RAIL		
7	DOOR LOCK STILE - CORE MATERIAL WOOD OR LVL		
8	DOOR SKIN (MIN. 0.070" THICK)		
9	DOOR SKIN (MIN. 0.140" THICK)		
10	REINFORCEMENT WOOD FOR LOCKS		
11	COMPRESSION WEATHERSTRIP-PE-650 QLON		
12	VINYL DOOR BOTTOM SWEEP-DBKAC		
13	CORNER PAD		
14	4" X 4" HINGE BUTT		
15	CONTINUOUS LATCH AND HINGE STILE REINFORCEMENT		
16	POLYURETHANE FOAM BY PLASTPRO		
17	EXTRUDED ALUMINUM ASTRAGAL BY ENDURA-6063T-6		
18	WOOD ASTRAGAL BY ENDURA		
19	LATCH STRIKE PLATE		
20	DEAD BOLT STRIKE PLATE		
21	KWIKSET KNOB (SIGNATURE SERIES)		
22	KWIKSET DEADBOLT (SIGNATURE SERIES 980 / 985)		
23	LATCH STRIKE PLATE 3500 / 3020		
24	DEADBOLT PLATE		
25	ASTRAGAL STRIKE PLATE		
26	TRILENNIUM 3500 / 3020 LOCK		
27	TRILENNIUM 3070 MULTIPOINT LOCK		
28	#10 X 3/4" PFH WOOD SCREW (HINGE TO FRAME)		
29	#10 X 2-1/2" PFH WOOD SCREW		
30	#10 X 1" PFH WOOD SCREW		
31	ODL GLAZING INSERT-ALUMINUM LIGHT FRAME		
32	RSL GLAZING INSERT-PVC FRAME		
33	ECLIPSE INTERIOR LOCK TRIM		
34	INSWING THRESHOLD ZACLA4565		
35	INSWING THRESHOLD ZAIL4565		
36	INSWING THRESHOLD ZAILAA4565		
37	TRILENNIUM 3000 MULTIPOINT LOCK		

REVISIONS			
REV	DESCRIPTION	DATE	APPROVED
C	REVISED PER NEW CODE	11/10/2021	R.L.

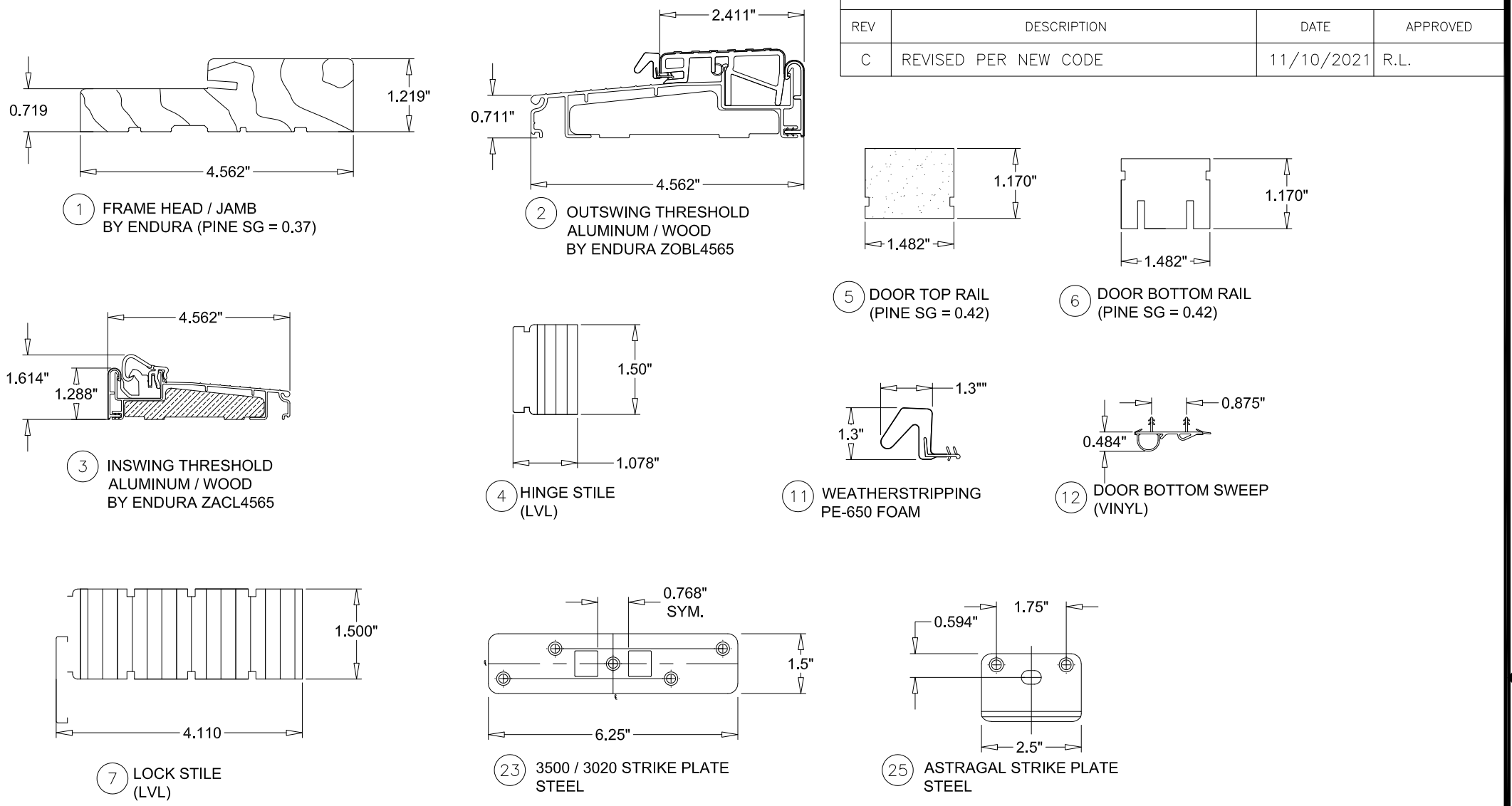

GENERAL PLASTICS NOTES:

- POLYURETHANE CORE FLAME SPREAD INDEX OF 50 AND SMOKE DEVELOPED INDEX OF 60 PER ASTM E84.
- PLASTICS TESTING OF FIBERLASS FACING:

Test Description	Test Method	Test Result
SELF IGNITION TEMP	ASTM D1929	Passed (>650 °F)
RATE OF BURNING	ASTM D635	Passed (C-1;<1.0 in/min)
SMOKE DENSITY	ASTM D2843	Passed (<75%)
TENSILE STRENGTH*	ASTM D638	Passed (<10%)

- PVC PLASTICS TESTING OF RSL LITE FRAME MATERIAL:

Test Description	Test Method	Test Result
SELF IGNITION TEMP	ASTM D1929	Passed (>650 °F)
RATE OF BURNING	ASTM D635	Passed (C-1;<1.0 in/min)
SMOKE DENSITY	ASTM D2843	Passed (<75%)
FLEXURAL STRENGTH*	ASTM D790	BEFORE = 3366 PSI AFTER = *3058 PSI

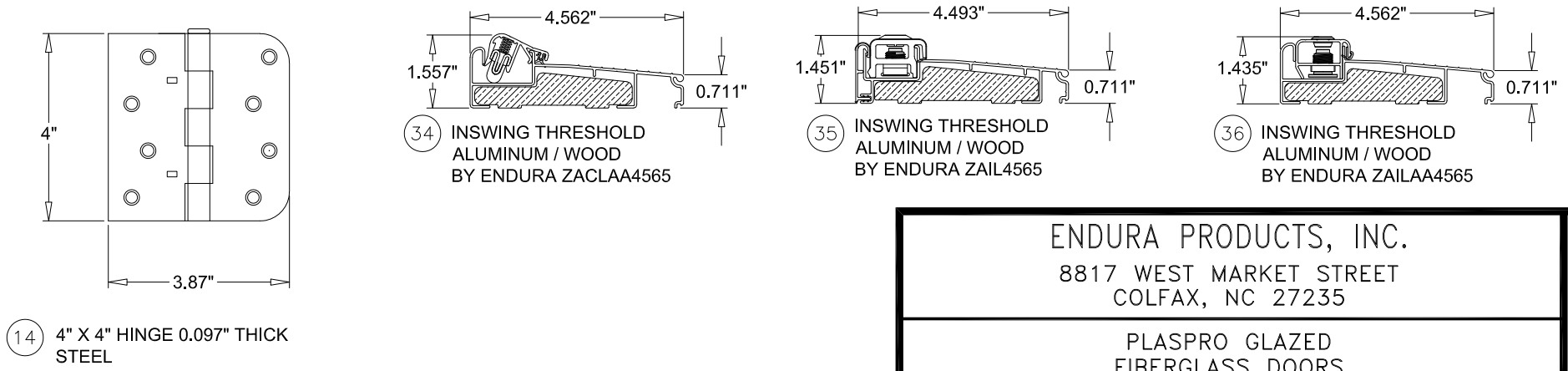

SIGNED: 11/10/2021

ENDURA PRODUCTS, INC.
 8817 WEST MARKET STREET
 COLFAX, NC 27235

PLASPRO GLAZED
 FIBERGLASS DOORS
 BILL OF MATERIALS AND COMPONENTS

DRAWN: RM	DWG NO. NL-0015	REV C
SCALE NTS	DATE 07/30/13	SHEET 9 OF 9

L. ROBERTO LOMAS P.E.
 1432 WOODFORD RD LEWISVILLE, NC 27023
 434-688-0609 rllomas@rlomaspe.com



Luis R. Lomas P.E.
 TX No.: 101889