

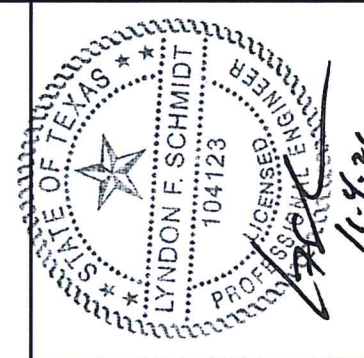

215 EAST ROOSEVELT AVE.  
ZEELAND, MI 49464



Documents Prepared By: Lyndon F. Schmidt, P.E.  
TEXAS P.E. #104123

**RW** BUILDING CONSULTANTS, INC.  
P.O. Box 230 Vairico FL 33595  
Phone No.: 813.659.9197

TEXAS BOARD OF PROFESSIONAL ENGINEERS  
CERTIFICATE OF REGISTRATION # F-11852

# FIBERGLASS ENTRY DOOR IN SWING "IMPACT"

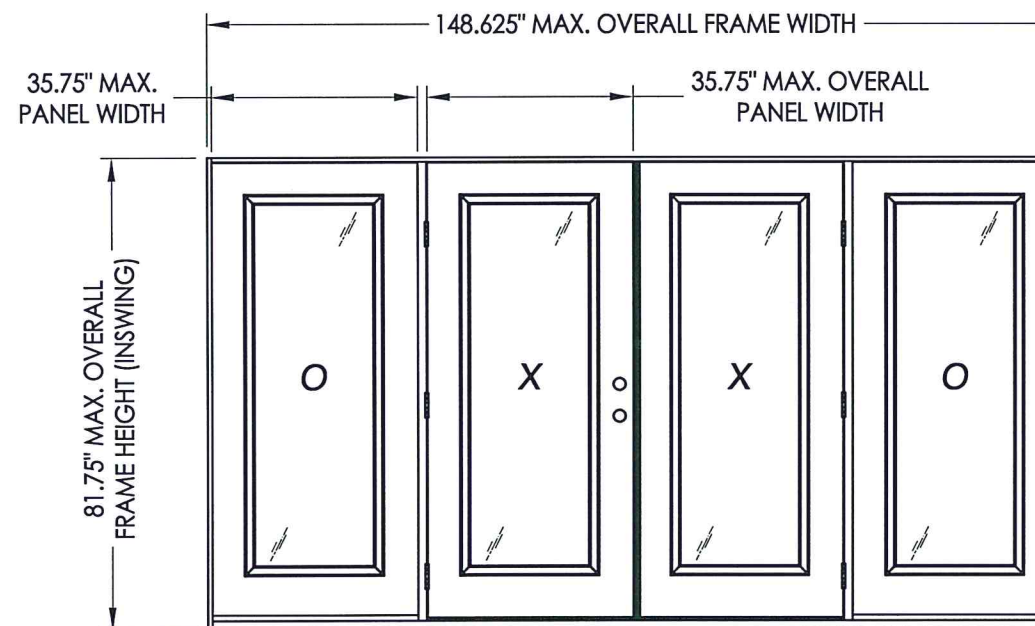

**CONTINUOUS HEAD & SILL**

CONFIGURATION	MAX. FRAME DIMENSION	DESIGN PRESSURE (PSF) INSWING	
		POSITIVE	NEGATIVE
OXXO	148.625" x 81.75"	+45.0	-50.0

EVALUATED FOR USE IN THE STATE OF TEXAS

**TDI DR-692**

The Fiberglass Door system described herein complies with the 2018 International Residential Code (IRC), Sections R301 & R609 and the 2018 International Building Code (IBC), Sections 1404.13, 1609, 1709.5, 2403 and 2404 subject to the following conditions:

1. Anchors shall be as listed and spaced as shown in the details. Anchor embedment to base material shall be beyond wall dressing or stucco.
2. This system has been tested and evaluated as a large missile impact protective system for installation in areas that require wind borne debris protection. This product meets missile level "D" as defined in ASTM E 1996.
3. Allowable design pressure requirements must be equal to or less than the design pressure rating shown in the design pressure chart, sheet 1 of this drawing.
4. Conditions not covered by this drawing are subject to further engineering analysis.

**TABLE OF CONTENTS**

SHEET #	DESCRIPTION
1	Typical elevations, design pressures & general notes
2	Door/Sidelite panel details
3	Lite frame and glazing details
4	Elevation & hardware table
5	Horizontal cross sections
6	Vertical cross sections
7	Vertical cross sections
8	Frame anchoring
9	Astragal details
10	Bill of materials & components

PRODUCT: FIBERGLASS DOOR  
PART OR ASSEMBLY: TYPICAL ELEVATION, DESIGN PRESSURES & GENERAL NOTES

NO.	DATE	BY	REVISIONS
3	10/26/21	LFS	UPDATE TO 2018 IRC/IBC
2	5/31/18	LFS	ADD FLAT FRAME LITE PROFILE
1	12/14/15	JK	ADD H.S. GLAZING OPTION

DATE: 6/13/13

SCALE: N.T.S.

DWG. BY: JK

CHK. BY: LFS

DRAWING NO.: TX-4375

SHEET 1 of 10

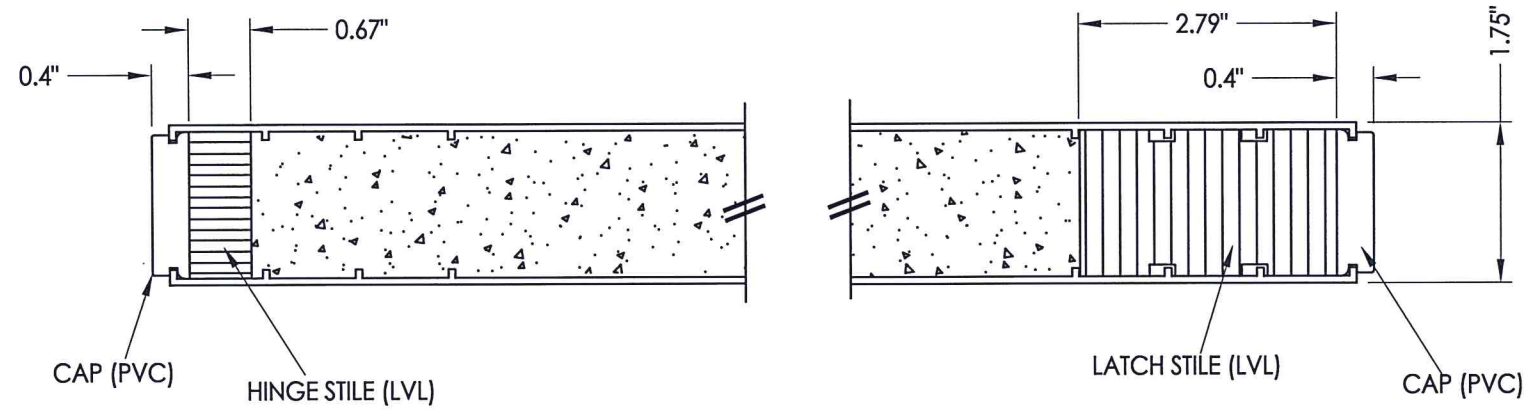

**1**  
**2** HORIZONTAL CROSS SECTION

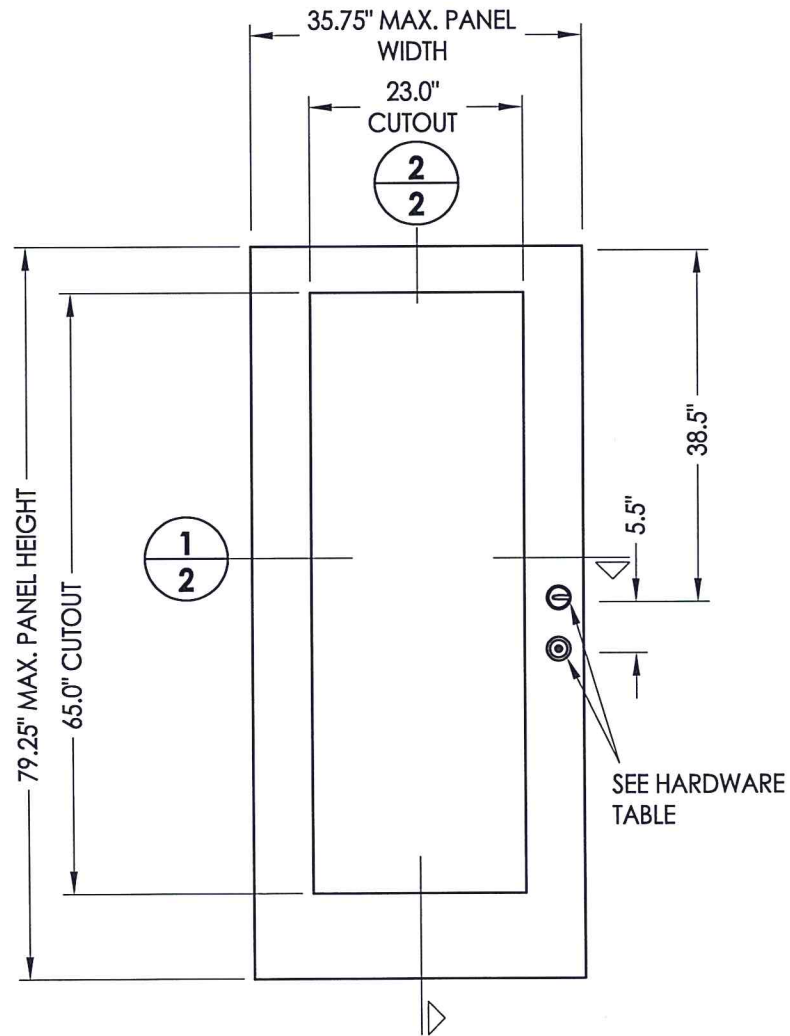

- 40** DOOR PANEL  
Plastpro
- 50** SIDELITE PANEL  
Fiberglass (Plastpro)

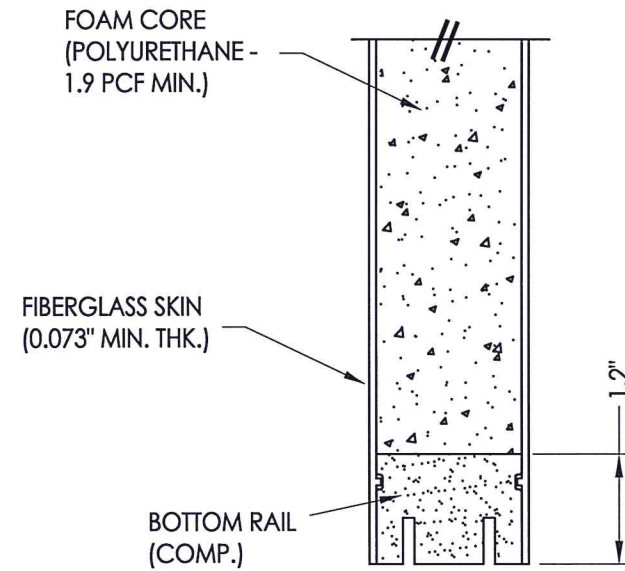
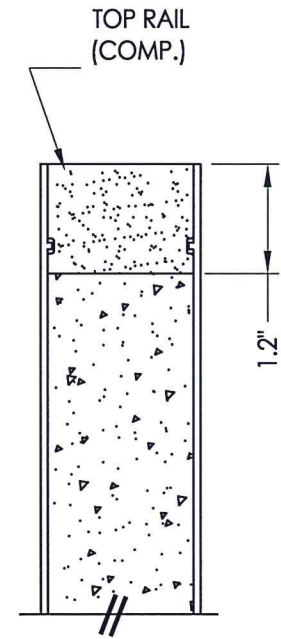

**2**  
**2** VERTICAL CROSS SECTION



Documents Prepared By: Lyndon F. Schmidt, P.E.  
TEXAS P.E. #104123

**RW** BUILDING CONSULTANTS, INC.  
P.O. Box 230 Vairico FL 33595  
Phone No.: 813.659.9197  
TEXAS BOARD OF PROFESSIONAL ENGINEERS  
CERTIFICATE OF REGISTRATION # F-11852

PRODUCT: FIBERGLASS DOOR  
PART OR ASSEMBLY: DOOR/SIDELITE PANEL DETAILS

NO.	DATE	REVISIONS	BY
3	10/26/21	UPDATE TO 2018 IBC/IRC	LFS
2	5/31/18	ADD FLAT FRAME LITE PROFILE	LFS
1	12/14/15	ADD H.S. GLAZING OPTION	JK

DATE: 6/13/13  
SCALE: N.T.S.  
DWG. BY: JK  
CHK. BY: LFS  
DRAWING NO.: TX-4375  
SHEET 2 OF 10



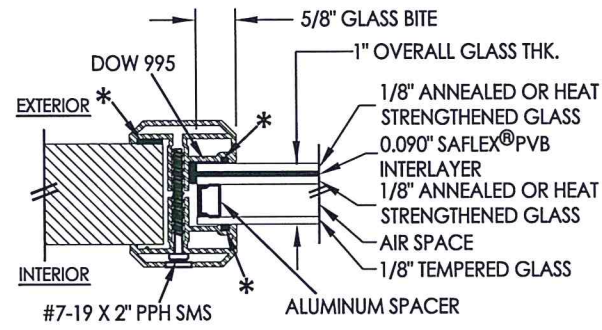

**G1 GLAZING DETAIL**  
Flat Frame Profile

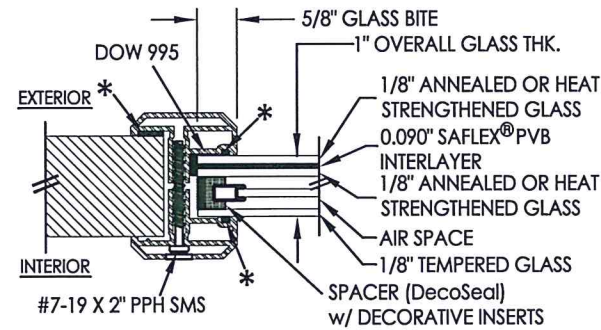

**G3 GLAZING DETAIL**  
Flat Frame Profile

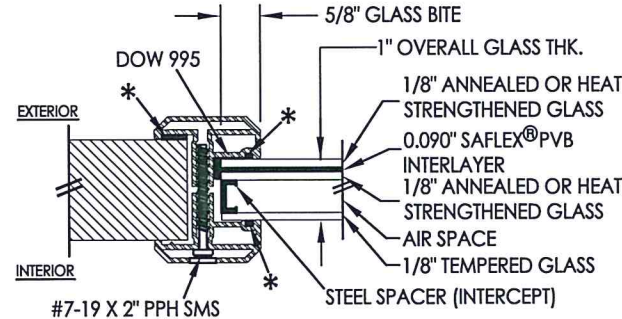

**G2 GLAZING DETAIL**  
Flat Frame Profile

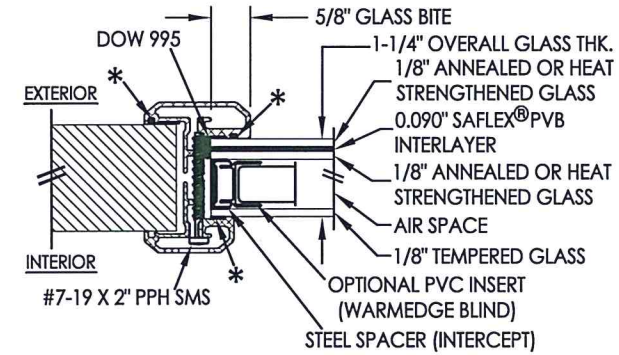

**G4 GLAZING DETAIL**  
Flat Frame Profile  
w/ Blinds Between Glass

\* NON-STRUCTURAL  
BACKBEDDING  
(READI-SEAL)

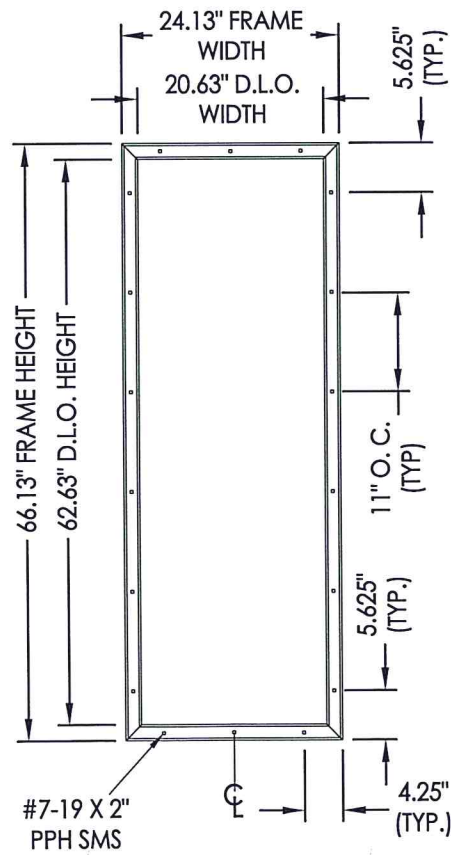

**ODL LITE FRAME**  
"Flat Frame" Aluminum

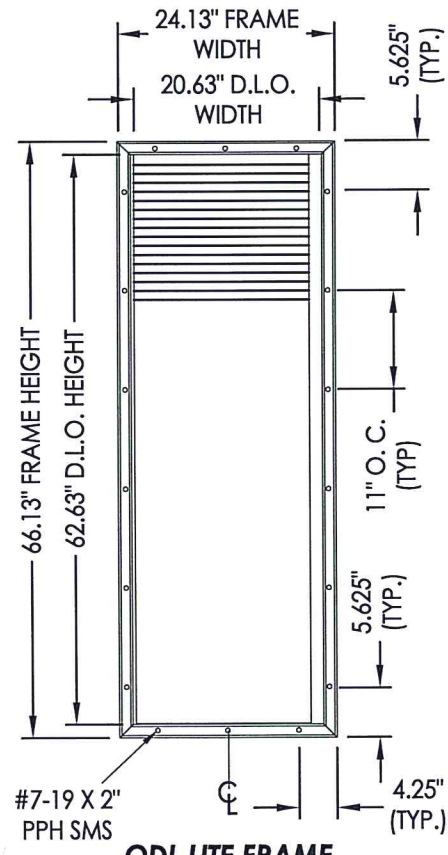

**ODL LITE FRAME**  
"Flat Frame" Aluminum  
w/ Blinds Between Glass

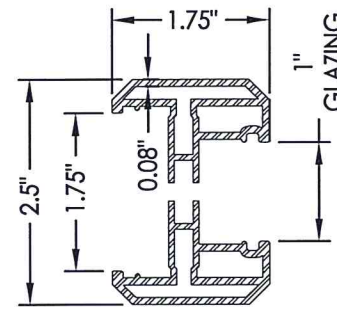

**ODL LITE FLAT FRAME**  
1" GLAZING

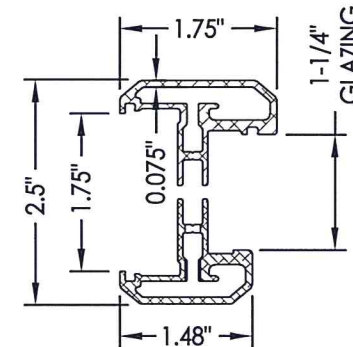

**ODL LITE FLAT FRAME**  
1-1/4" GLAZING

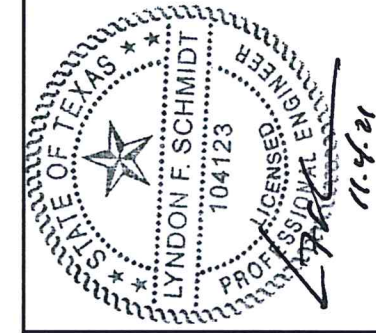

Documents Prepared By: Lyndon F. Schmidt, P.E.  
TEXAS P.E. #104123

**RW** BUILDING CONSULTANTS, INC.  
P.O. Box 230 Valrico FL, 33595  
Phone No.: 813.659.9197  
TEXAS BOARD OF PROFESSIONAL ENGINEERS  
CERTIFICATE OF REGISTRATION # F-11852

PRODUCT: FIBERGLASS DOOR

PART OR ASSEMBLY: LITE FRAME & GLAZING DETAILS

NO.	DATE	REVISIONS
3	10/26/21	UPDATE TO 2018 IBC/IRC
2	5/31/18	ADD FLAT FRAME LITE PROFILE
1	12/14/15	ADD H.S. GLAZING OPTION

DATE: 6/13/13  
SCALE: N.T.S.  
DWG. BY: JK  
CHK. BY: LFS  
DRAWING NO.: TX-4375  
SHEET 3 OF 10

HARDWARE TABLE		
MANUFACTURER	MODEL	
KWIKSET	KNOB: DEADBOLT:	SIGNATURE SERIES SIGNATURE SERIES (980)
SCHLAGE	KNOB: DEADBOLT:	"F" SERIES (F60) "B" SERIES (B60/62)
PAMEX *	KNOB: DEADBOLT:	"F" SERIES "FD7" SERIES

\* MAX. DESIGN PRESSURE FOR PAMEX LOCK  
INSWING = +40/-50 PSF

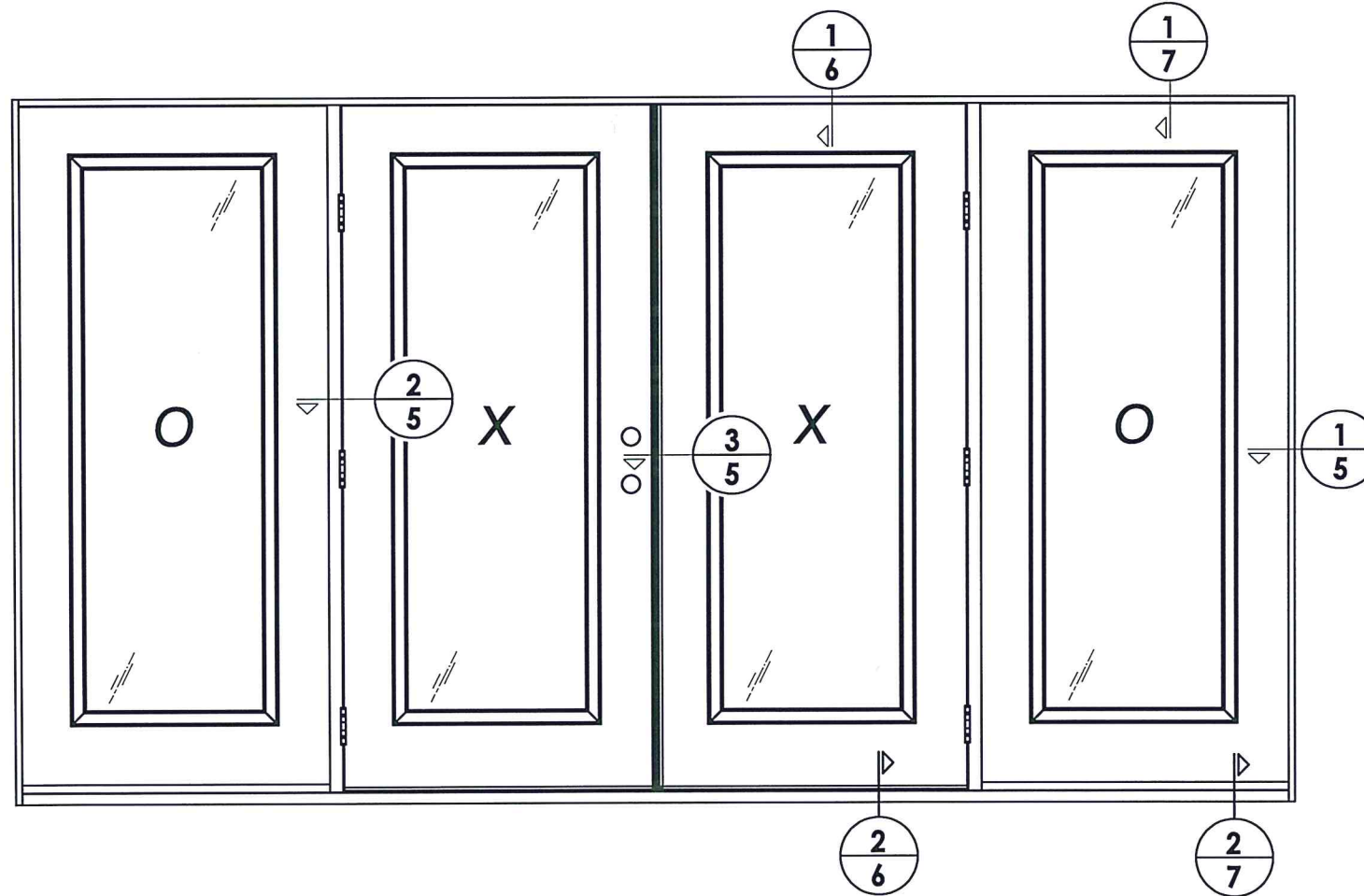

ELEVATION (OXXO)

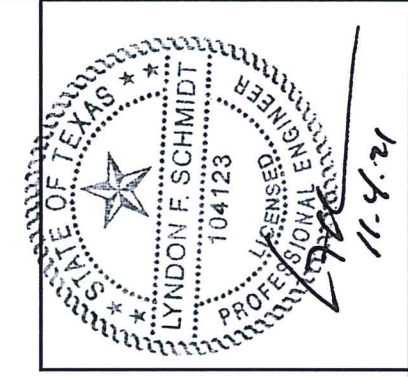

Documents Prepared By: Lyndon F. Schmidt, P.E.  
TEXAS P.E. #104123

**RW** BUILDING CONSULTANTS, INC.  
P.O. Box 230 Vairico FL 33595  
Phone No.: 813.659.9197

TEXAS BOARD OF PROFESSIONAL ENGINEERS  
CERTIFICATE OF REGISTRATION # F-11852

PRODUCT: FIBERGLASS DOOR  
PART OR ASSEMBLY: ELEVATION & HARDWARE TABLE

NO.	DATE	REVISIONS
3	10/26/21	UPDATE TO 2018 IBC/IRC
2	5/31/18	ADD FLAT FRAME LITE PROFILE
1	12/14/15	ADD H.S. GLAZING OPTION

DATE: 6/13/13  
SCALE: N.T.S.  
DWG. BY: JK  
CHK. BY: LFS  
DRAWING NO.: TX-4375  
SHEET 4 of 10



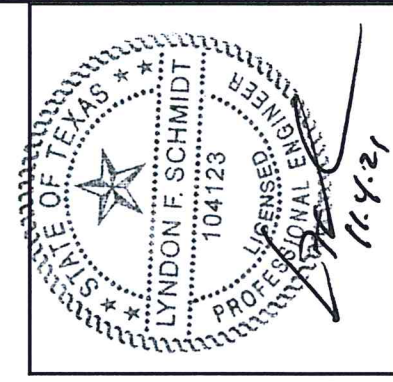

Documents Prepared By: Lyndon F. Schmidt, P.E.  
 TEXAS P.E. #104123

**RW** BUILDING CONSULTANTS, INC.  
 P.O. Box 230 Vairico FL 33595  
 Phone No.: 813.659.9197

TEXAS BOARD OF PROFESSIONAL ENGINEERS  
 CERTIFICATE OF REGISTRATION # F-11852

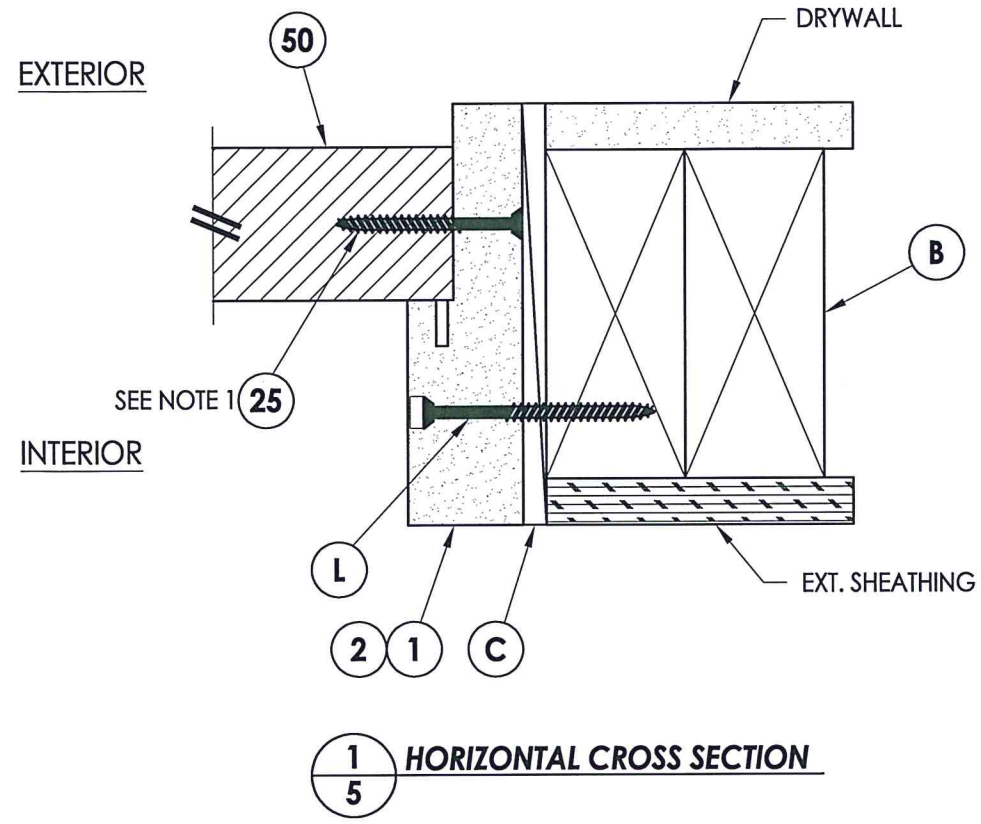

NOTE:  
 1. Sidelite panel screws located 6" from each end plus 4 more equally spaced (6 screws total).

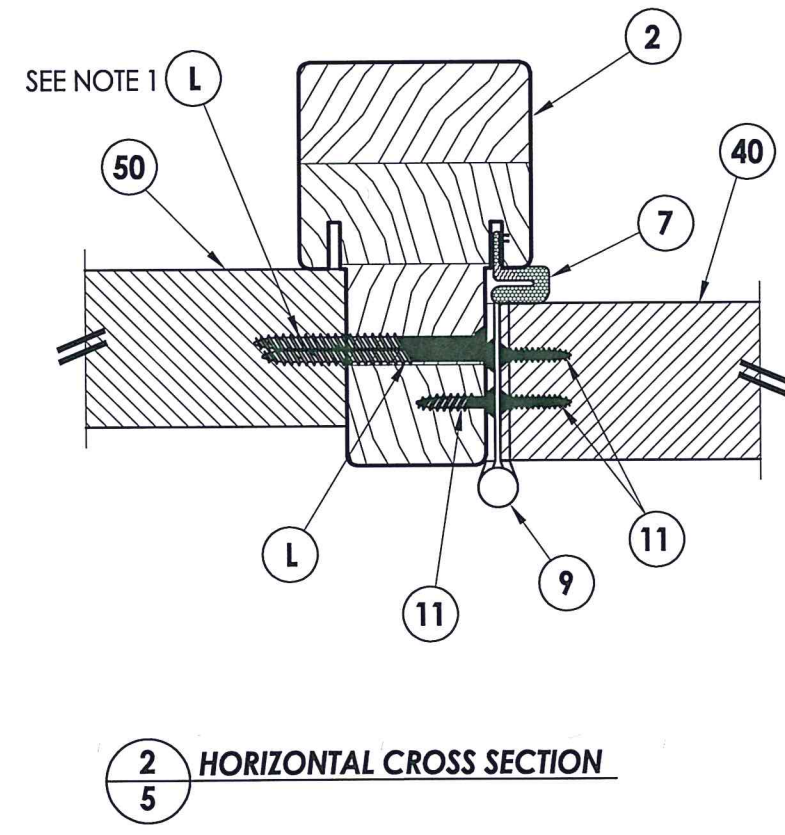

EXTERIOR

INTERIOR

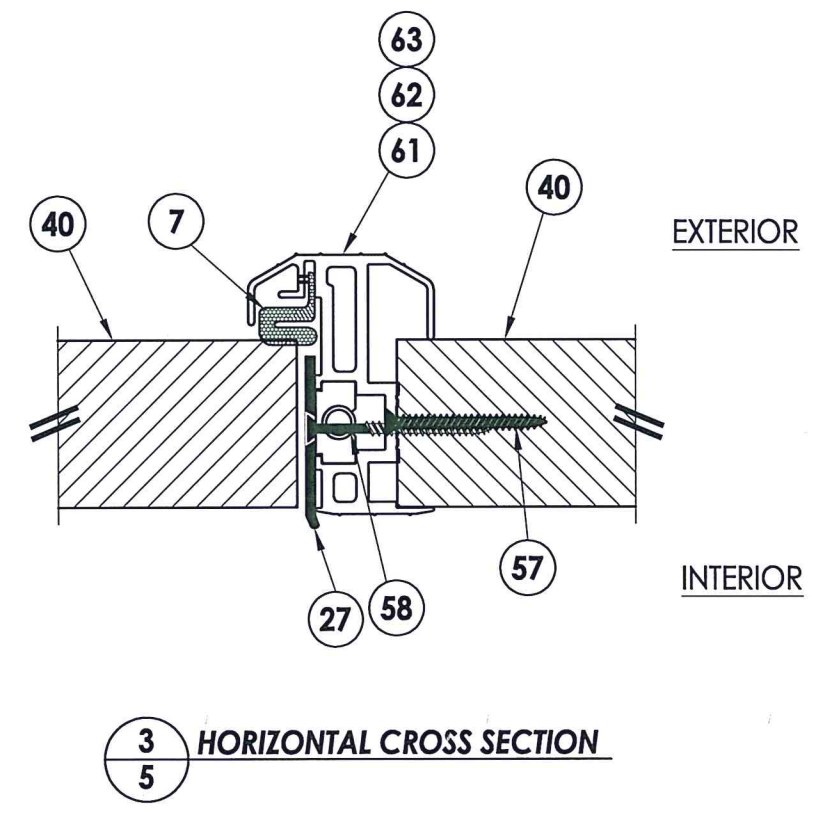

PRODUCT: FIBERGLASS DOOR

PART OR ASSEMBLY: HORIZONTAL CROSS SECTIONS

NO.	DATE	REVISIONS
3	10/26/21	UPDATE TO 2018 IBC/IRC
2	5/31/18	ADD FLAT FRAME LITE PROFILE
1	12/14/15	ADD H.S. GLAZING OPTION
LFS		
LFS		
JK		
BY		

DATE: 6/13/13

SCALE: N.T.S.

DWG. BY: JK

CHK. BY: LFS

DRAWING NO.: TX-4375

SHEET 5 of 10

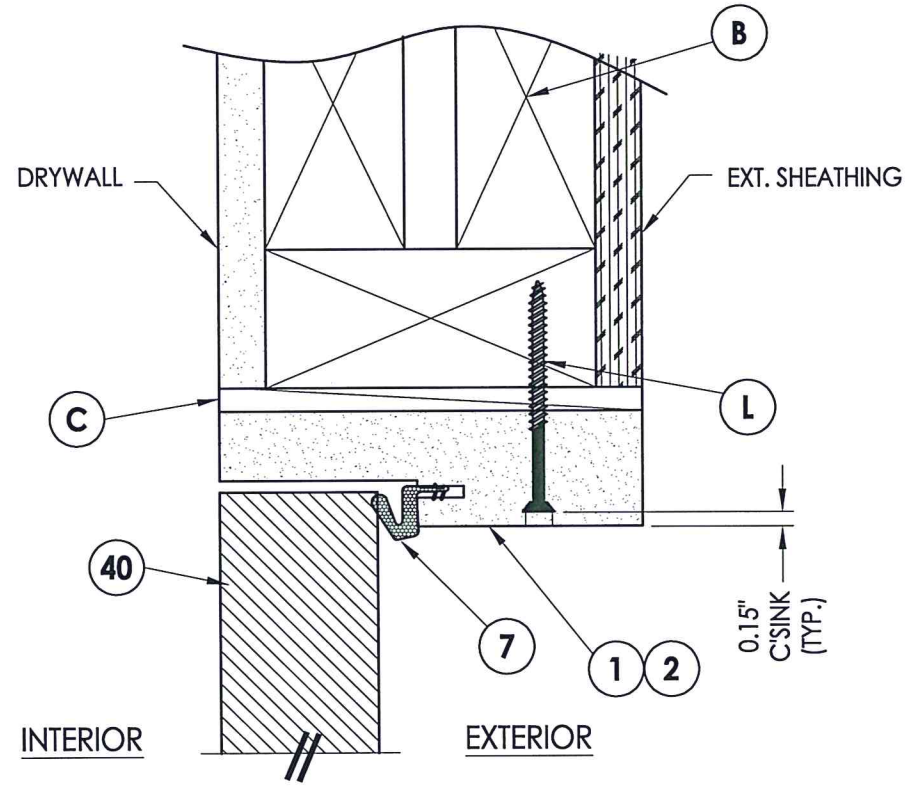

1  
6 VERTICAL CROSS SECTION

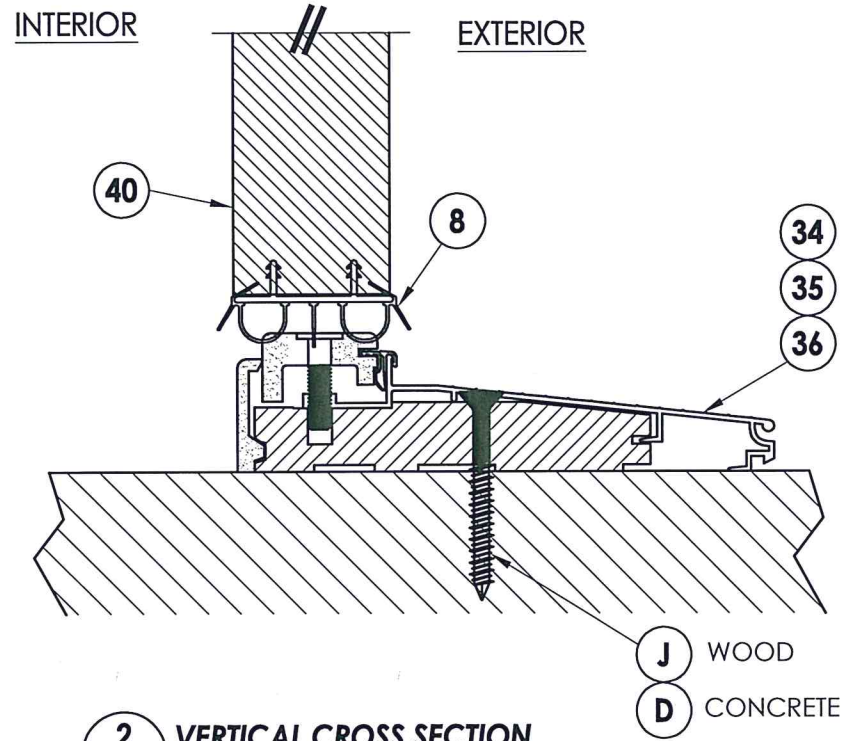

2  
6 VERTICAL CROSS SECTION



Documents Prepared By: Lyndon F. Schmidt, P.E.  
TEXAS P.E. #104123

**RW** BUILDING CONSULTANTS, INC.  
P.O. Box 230 Vairico FL, 33595  
Phone No.: 813.659.9197  
TEXAS BOARD OF PROFESSIONAL ENGINEERS  
CERTIFICATE OF REGISTRATION # F-11852

PRODUCT: FIBERGLASS DOOR  
PART OR ASSEMBLY: VERTICAL CROSS SECTIONS

NO.	DATE	REVISIONS
3	10/26/21	UPDATE TO 2018 IBC/IRC
2	5/31/18	ADD FLAT FRAME LITE PROFILE
1	12/14/15	ADD H.S. GLAZING OPTION

DATE: 6/13/13  
SCALE: N.T.S.  
DWG. BY: JK  
CHK. BY: LFS  
DRAWING NO.: TX-4375  
SHEET 6 of 10



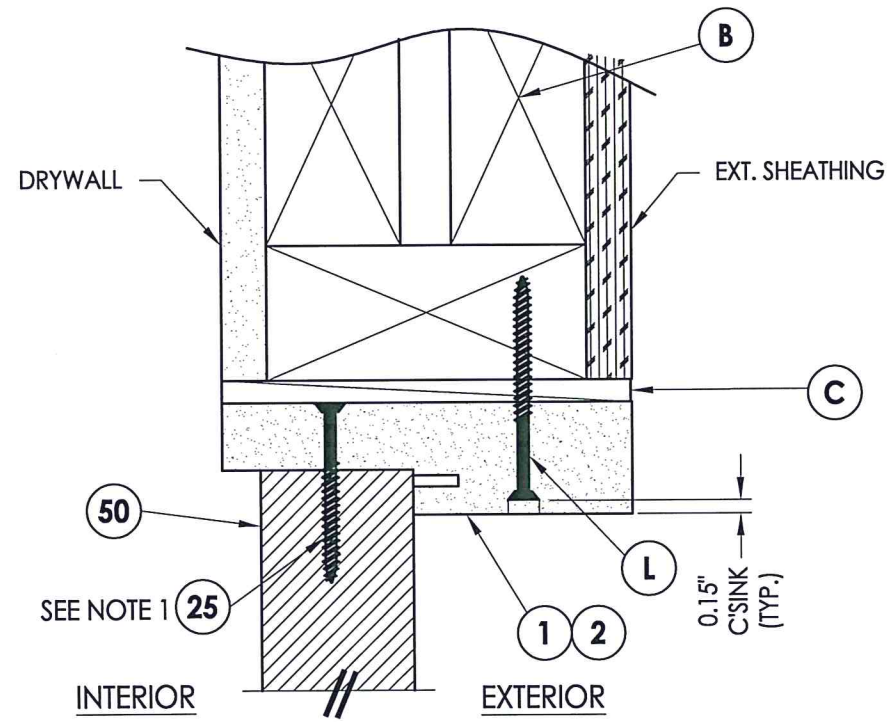

**1**  
**7** VERTICAL CROSS SECTION

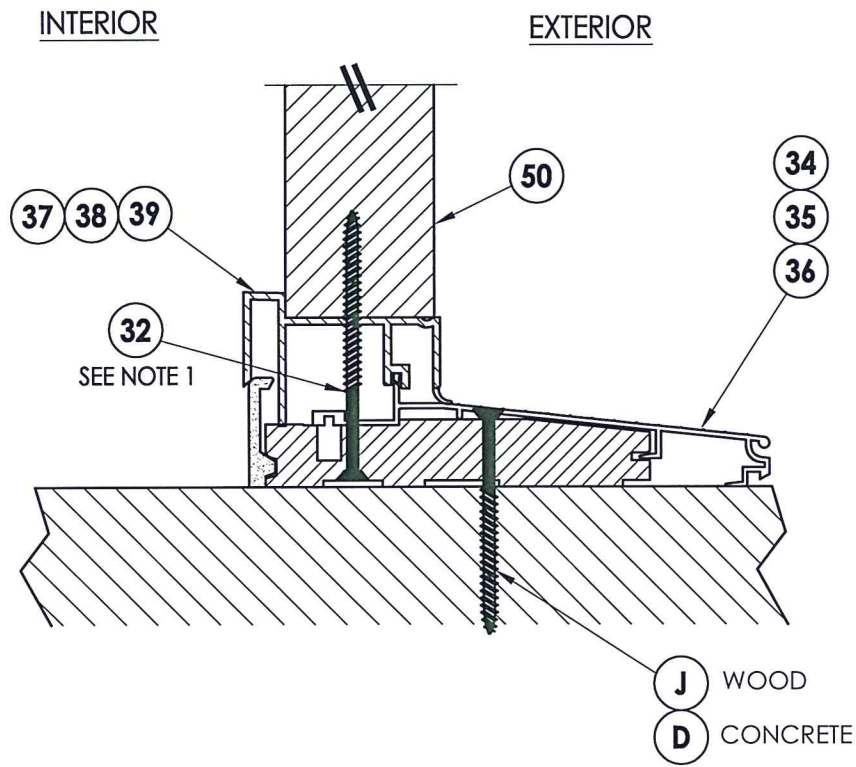

**2**  
**7** VERTICAL CROSS SECTION

NOTE:  
1. Sidelite panel screws located 6" from each end (2 Total).

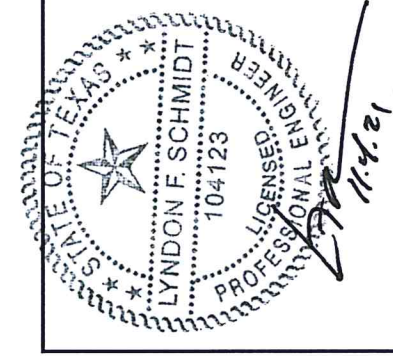

Documents Prepared By: Lyndon F. Schmidt, P.E.  
TEXAS P.E. #104123

**RW** BUILDING CONSULTANTS, INC.  
P.O. Box 230 Valrico FL 33595  
Phone No.: 813.659.9197  
TEXAS BOARD OF PROFESSIONAL ENGINEERS  
CERTIFICATE OF REGISTRATION # F-11852

PRODUCT:	FIBERGLASS DOOR
PART OR ASSEMBLY:	VERTICAL CROSS SECTIONS

NO.	DATE	BY	REVISIONS
3	10/26/21	LFS	UPDATE TO 2018 IBC/IRC
2	5/31/18	LFS	ADD FLAT FRAME LITE PROFILE
1	12/14/15	JK	ADD H.S. GLAZING OPTION

DATE:	6/13/13
SCALE:	N.T.S.
DWG. BY:	JK
CHK. BY:	LFS
DRAWING NO.:	TX-4375
SHEET	7 of 10

Z:\Clients\ODL, Inc. PERMANENT\B - Texas Dept of Ins\TDI - 692\Drawings\TX-4374-75.dwg

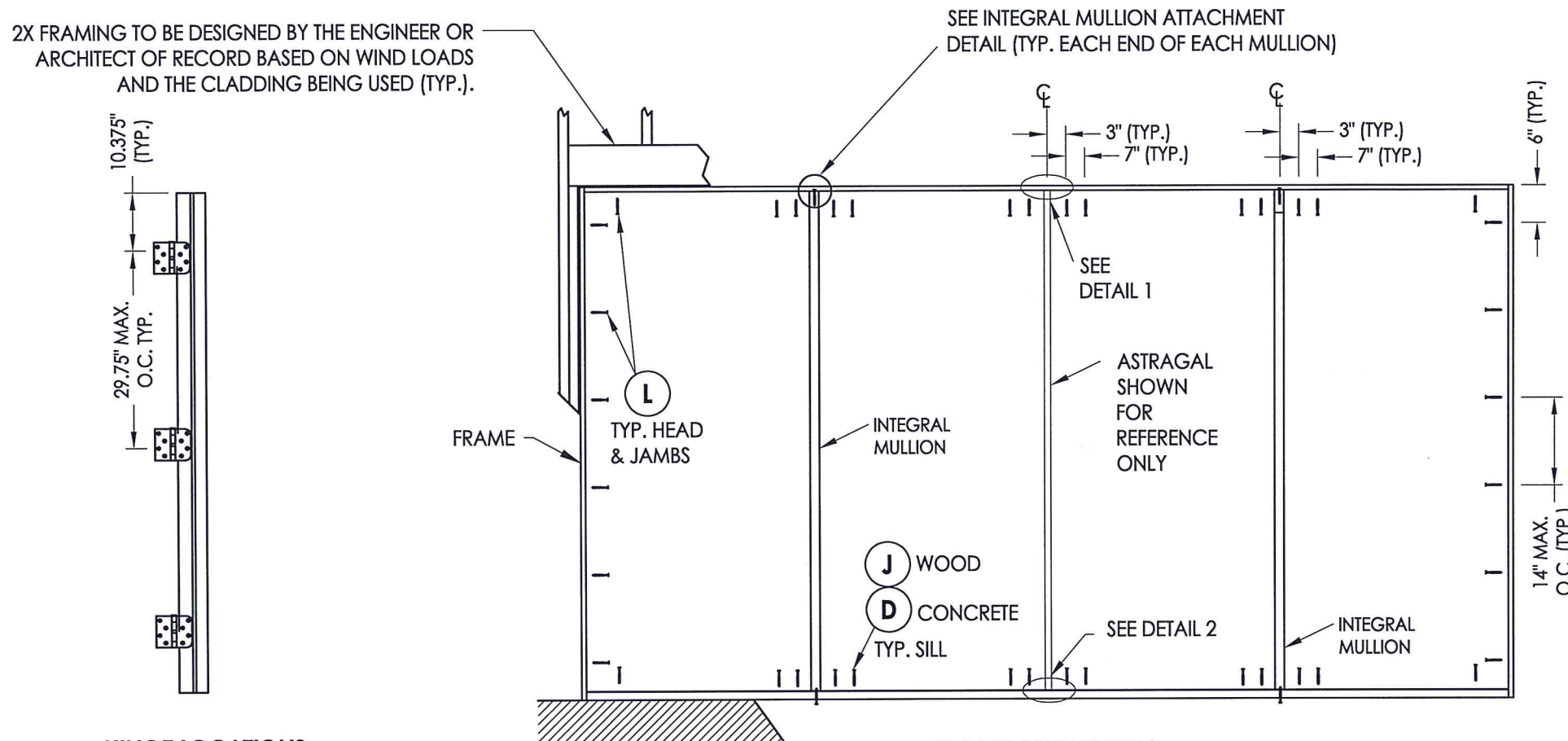

**HINGE LOCATIONS**

**FRAME ANCHORING**  
OXO

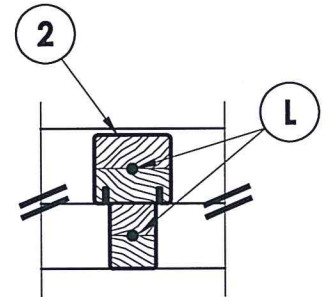

**INTEGRAL MULLION ATTACHMENT DETAIL**

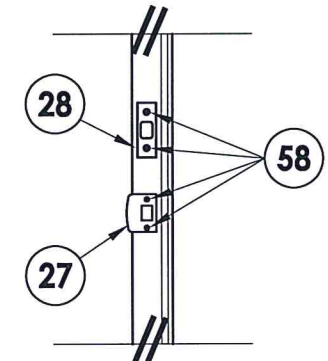

**LATCH & DEAD BOLT DETAIL**  
Kwikset / Schlage / Pamex

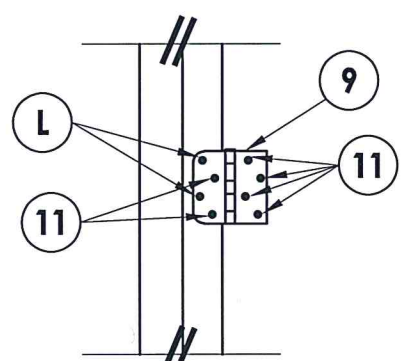

**HINGE DETAIL**  
Inswing

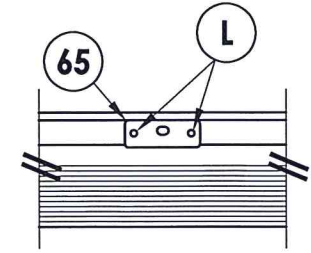

**DETAIL 2**  
Astragal strike @ sill  
(Inswing)

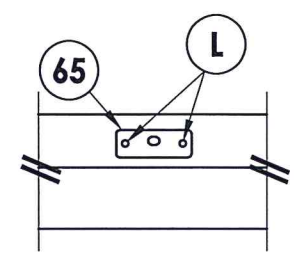

**DETAIL 1**  
Astragal strike @ head

**CONCRETE ANCHOR NOTES:**

1. Concrete anchor locations at the corners may be adjusted to maintain the min. edge distance to mortar joints.
2. Concrete anchor locations noted as "MAX. ON CENTER" must be adjusted to maintain the min. edge distance to mortar joints, additional concrete anchors may be required to ensure the "MAX. ON CENTER" dimension are not exceeded.
3. Concrete anchor table:

ANCHOR TYPE	ANCHOR SIZE	MIN. EMBEDMENT	MIN. CLEARANCE TO MASONRY EDGE	MIN. CLEARANCE TO ADJACENT ANCHOR
ITW TAPCON®	1/4"	1-3/4"	1-1/2"	4"
DeWALT ULTRACON®	1/4"	1-3/4"	1"	3"

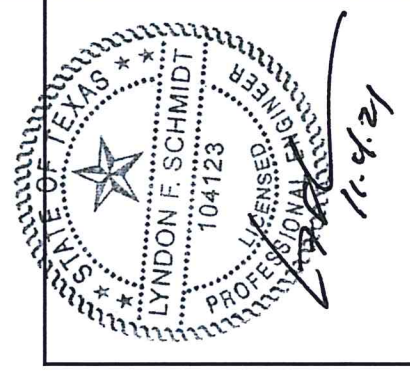

Documents Prepared By: Lyndon F. Schmidt, P.E.  
TEXAS P.E. #104123

**RW** BUILDING CONSULTANTS, INC.  
P.O. Box 230 Vairico FL 33595  
Phone No.: 813.659.9197

TEXAS BOARD OF PROFESSIONAL ENGINEERS  
CERTIFICATE OF REGISTRATION # F-11852

PRODUCT: FIBERGLASS DOOR

PART OR ASSEMBLY: FRAME ANCHORING

NO.	DATE	BY	REVISIONS
3	10/26/21	LFS	UPDATE TO 2018 IBC/IRC
2	5/31/18	LFS	ADD FLAT FRAME LITE PROFILE
1	12/14/15	JK	ADD H.S. GLAZING OPTION

DATE: 6/13/13

SCALE: N.T.S.

DWG. BY: JK

CHK. BY: LFS

DRAWING NO.: TX-4375

SHEET 8 OF 10



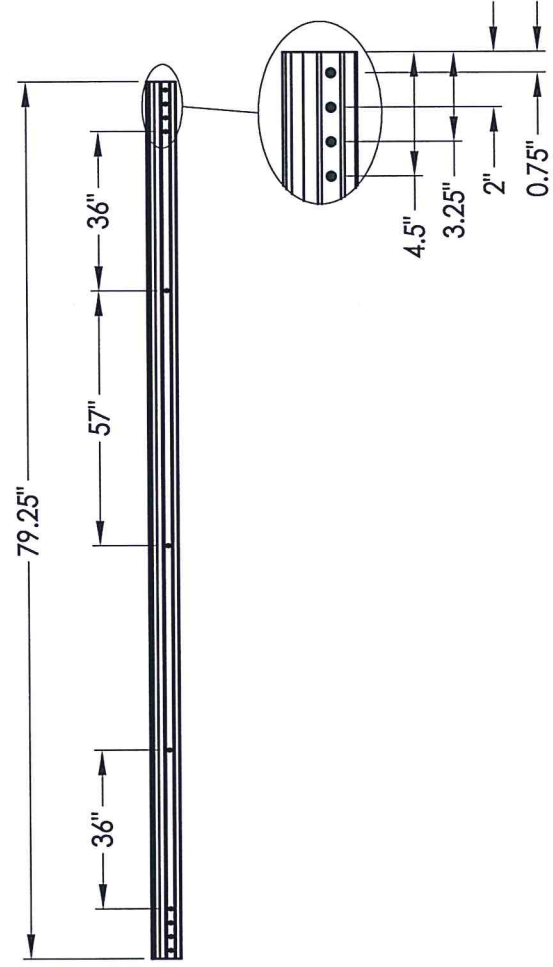

ASTRAGAL SCREW LOCATIONS

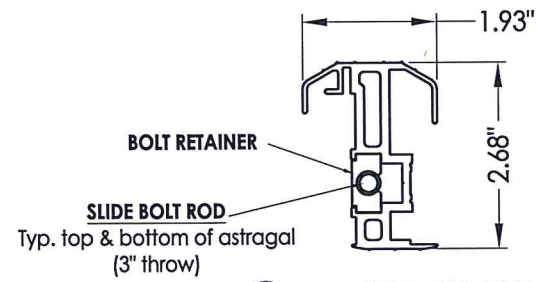

**61 ALUMINUM ASTRAGAL**  
Therma-Tru

**6'8 ALUMINUM ASTRAGAL ASSEMBLY**  
Therma-Tru

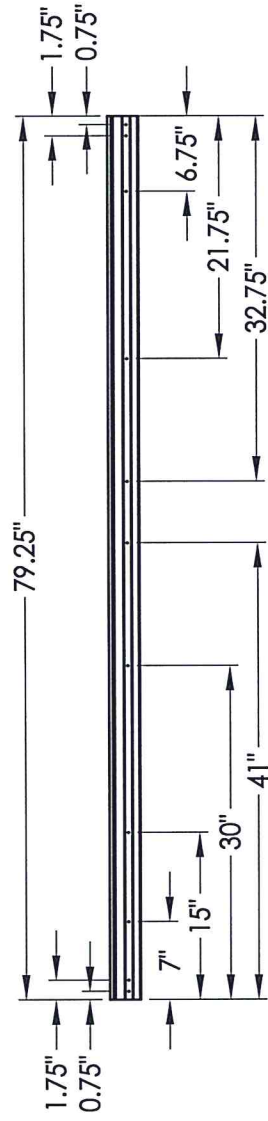

ASTRAGAL SCREW LOCATIONS

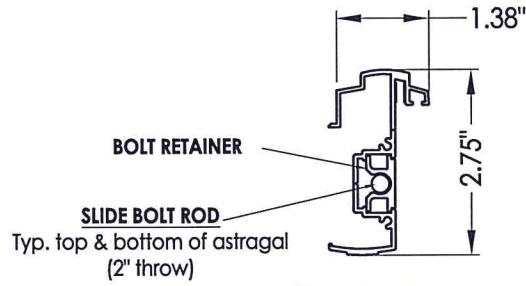

**62 ASTRAGAL**  
Columbia

**6'8 ALUMINUM ASTRAGAL ASSEMBLY**  
Columbia

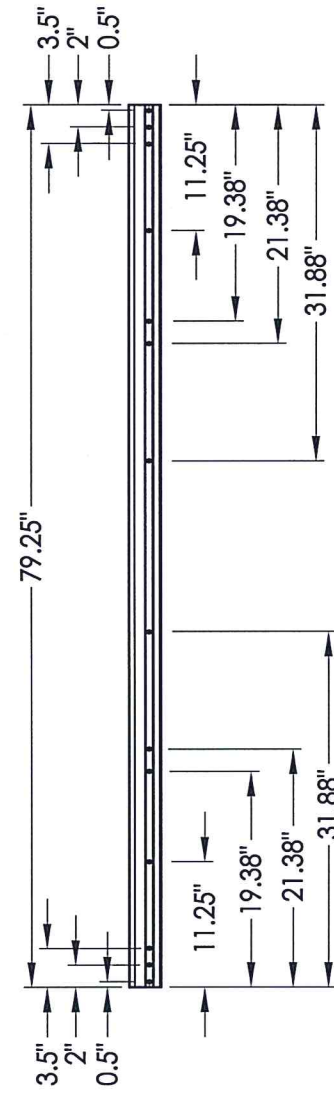

ASTRAGAL SCREW LOCATIONS

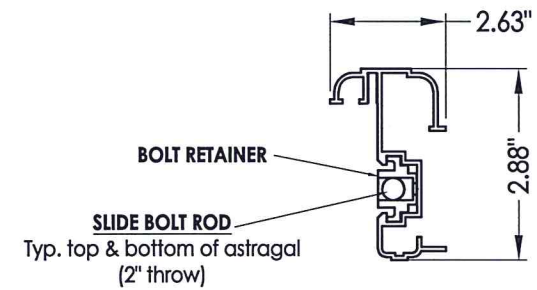

**63 ASTRAGAL**  
DLP

**6'8 ALUMINUM ASTRAGAL ASSEMBLY**  
DLP



Documents Prepared By: Lyndon F. Schmidt, P.E.  
TEXAS P.E. #104123

**RW** BUILDING CONSULTANTS, INC.  
P.O. Box 230 Valrico FL 33595  
Phone No.: 813.659.9197

TEXAS BOARD OF PROFESSIONAL ENGINEERS  
CERTIFICATE OF REGISTRATION # F-11852

PRODUCT:		FIBERGLASS DOOR	
PART OR ASSEMBLY:		ASTRAGAL DETAILS	
NO.	DATE	BY	REVISIONS
3	10/26/21	LFS	UPDATE TO 2018 IBC/IRC
2	5/31/18	LFS	ADD FLAT FRAME LITE PROFILE
1	12/14/15	JK	ADD H.S. GLAZING OPTION

DATE: 6/13/13

SCALE: N.T.S.

DWG. BY: JK

CHK. BY: LFS

DRAWING NO.: TX-4375

SHEET 9 OF 10



Z:\Clients\ODL, Inc. PERMANENT\B - Texas Dept of Ins\TDI - 692\Drawings\TX-4374-75.dwg

BILL OF MATERIALS		
ITEM #	DESCRIPTION	MATERIAL
B	2X FRAMING (G >= 0.42)	WOOD
C	1/4" MAX. SHIM SPACE	-
D	1/4" PFH DeWALT OR ITW CONCRETE SCREW (1-3/4" MIN. EMB.)	STEEL
J	#10 X 3" PFH WOOD SCREW (1-1/2" MIN. EMB.)	STEEL
L	#10 X 2-1/2" PFH WOOD SCREW (1.15" MIN. EMB.)	STEEL
1	HEAD & JAMB	WOOD
2	HEAD & JAMB	COMP
7	WEATHERSTRIP	FOAM
8	DOOR BOTTOM SWEEP	VINYL
9	4" x 4" HINGE	STEEL
11	#9 X 3/4" PFH WOOD SCREW	STEEL
24	#10 X 1-1/2" PFH WOOD SCREW	STEEL
25	#10 X 2" PFH WOOD SCREW	STEEL
27	LATCH STRIKE PLATE	STEEL
28	DEADBOLT STRIKE PLATE	STEEL
32	#8 X 3" PFH WS	STEEL
34	INSWING THRESHOLD	ALUM/COMP
35	INSWING THRESHOLD	ALUM/COMP
36	INSWING THRESHOLD	ALUM/COMP
37	INSWING SIDELITE SEAT	PVC
38	INSWING SIDELITE SEAT	PVC
39	INSWING SIDELITE SEAT	PVC
40	DOOR PANEL - SEE DOOR PANEL DETAIL SHEET FOR DETAILS	-
50	SIDELITE PANEL - SEE SIDELITE PANEL DETAIL SHEET FOR DETAILS	-
57	#8 X 2" PPH SMS	STEEL
58	#8 X 2-1/2" PFH WOOD SCREW	STEEL
61	ASTRAGAL (THERMA-TRU)	ALUM
62	ASTRAGAL (COLUMBIA)	ALUM
63	ASTRAGAL (DLP)	ALUM
65	ASTRAGAL STRIKE PLATE	STEEL

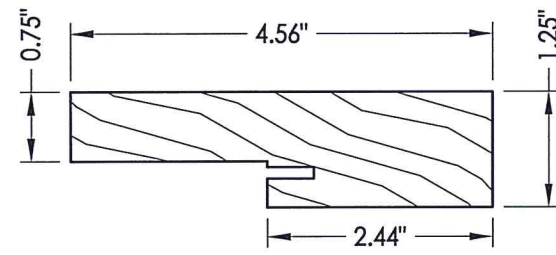

1 HEAD & JAMB  
Finger joint pine

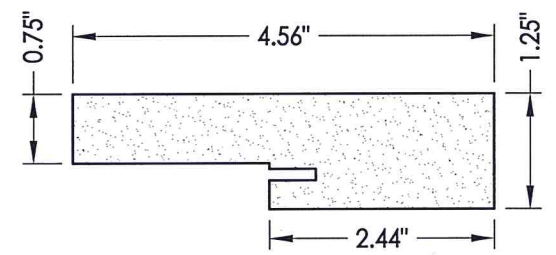

2 HEAD & JAMB  
Composite

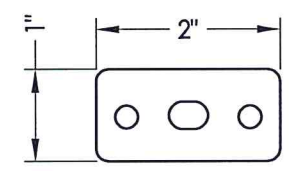

69 HEAD & SILL STRIKE PLATE

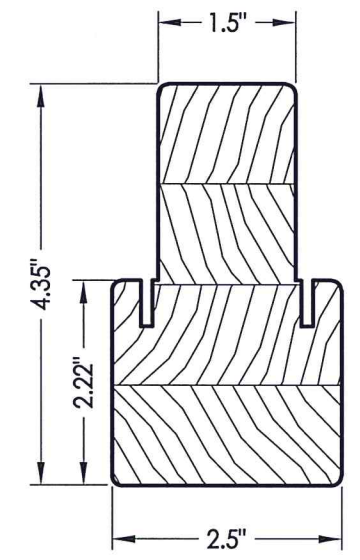

3 INTEGRAL MULLION

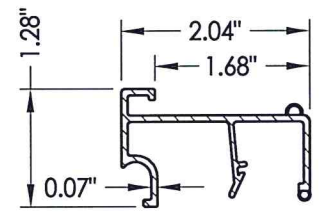

37 INSWING SIDELITE SEAT  
ENDURA 60 SERIES

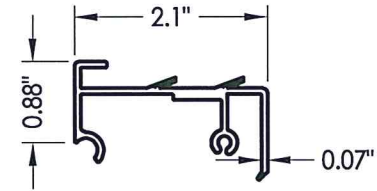

38 SIDELITE SPACER  
Columbia

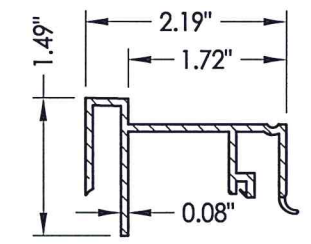

39 INSWING SIDELITE SEAT  
Therma-Tru

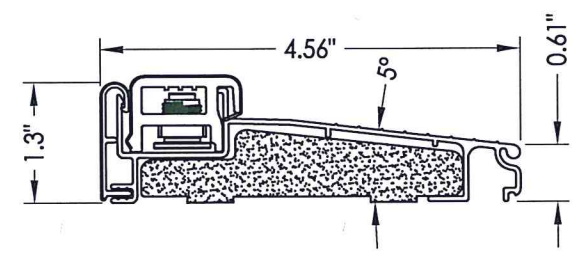

34 INSWING THRESHOLD  
ENDURA ZAIL 4565  
with Composite Substrate

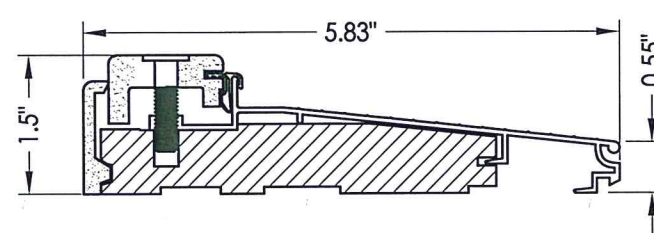

35 INSWING THRESHOLD  
Therma-Tru

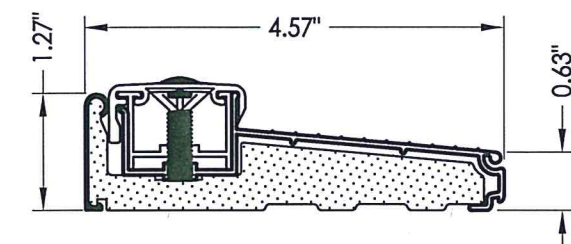

36 INSWING THRESHOLD  
Columbia 900 Series

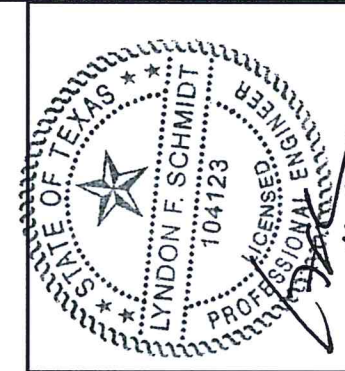

Documents Prepared By: Lyndon F. Schmidt, P.E.  
TEXAS P.E. #104123

RW BUILDING CONSULTANTS, INC.  
P.O. Box 230 Valrico FL 33595  
Phone No.: 813.659.9197  
TEXAS BOARD OF PROFESSIONAL ENGINEERS  
CERTIFICATE OF REGISTRATION # F-11852

PRODUCT: FIBERGLASS DOOR  
PART OR ASSEMBLY: BILL OF MATERIALS & COMPONENTS

NO.	DATE	REVISIONS
3	10/26/21	UPDATE TO 2018 IBC/IRC
2	5/31/18	ADD FLAT FRAME LITE PROFILE
1	12/14/15	ADD H.S. GLAZING OPTION

DATE: 6/13/13  
SCALE: N.T.S.  
DWG. BY: JK  
CHK. BY: LFS  
DRAWING NO.: TX-4375  
SHEET 10 OF 10