



215 EAST ROOSEVELT AVE.
ZEELAND, MI 49464

FIBERGLASS ENTRY DOOR IN SWING "IMPACT"



Documents Prepared By: Lyndon F. Schmidt, P.E.
TEXAS P.E. #104123

RW BUILDING CONSULTANTS, INC.
P.O. Box 230 Valrico FL 33595
Phone No.: 813.659.9197

TEXAS BOARD OF PROFESSIONAL ENGINEERS
CERTIFICATE OF REGISTRATION # F-11852

EVALUATED FOR USE IN THE STATE OF TEXAS

TDI DR-691

The Fiberglass Door system described herein complies with the 2018 International Residential Code (IRC), Sections R301 & R609 and the 2018 International Building Code (IBC), Sections 1404.13, 1609, 1709.5, 2403 and 2404 subject to the following conditions:

1. Anchors shall be as listed and spaced as shown in the details. Anchor embedment to base material shall be beyond wall dressing or stucco.
2. This system has been tested and evaluated as a large missile impact protective system for installation in areas that require wind borne debris protection. This product meets missile level "D" as defined in ASTM E 1996.
3. Allowable design pressure requirements must be equal to or less than the design pressure rating shown in the design pressure chart, sheet 1 of this drawing.
4. Conditions not covered by this drawing are subject to further engineering analysis.
5. Fiber-Classic and Smooth-Star Door panels require the use of "J" part numbers. These door panels must be stained or painted within six months of installation.

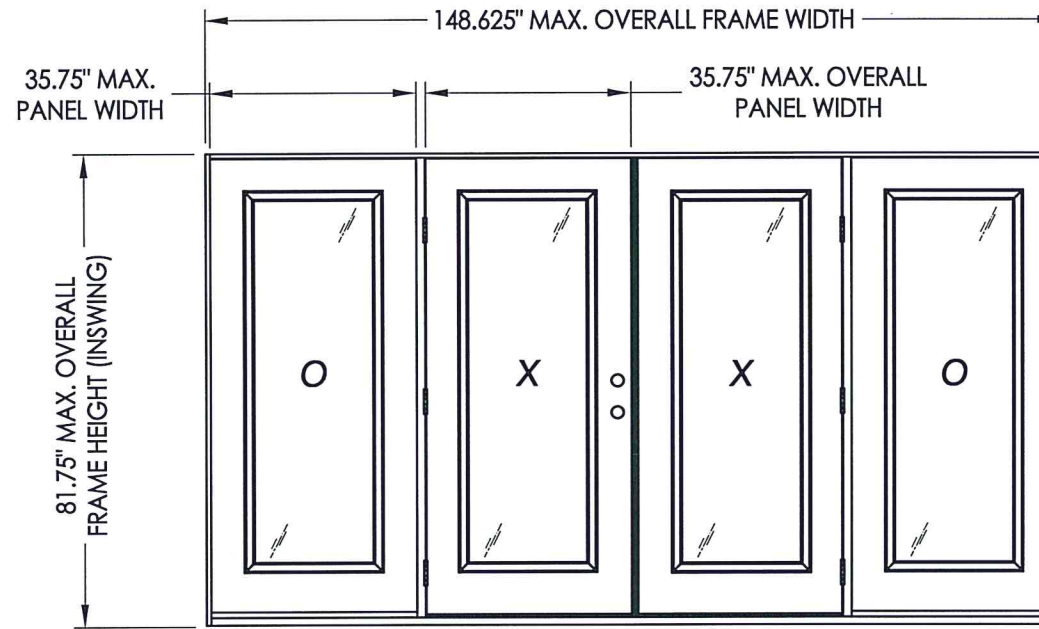

CONTINUOUS HEAD & SILL

TABLE OF CONTENTS	
SHEET #	DESCRIPTION
1	Typical elevations, design pressures & general notes
2	Door/Sidelite panel details
3	Lite frame and glazing details
4	Elevation & hardware table
5	Horizontal cross sections
6	Vertical cross sections
7	Vertical cross sections
8	Frame anchoring
9	Astragal details
10	Bill of materials & components

CONFIGURATION	MAX. FRAME DIMENSION	DESIGN PRESSURE (PSF) INSWING	
		POSITIVE	NEGATIVE
OXXO	148.625" x 81.75"	+45.0	-50.0

PRODUCT: FIBERGLASS DOOR
PART OR ASSEMBLY: TYPICAL ELEVATION, DESIGN PRESSURES & GENERAL NOTES

NO.	DATE	BY	REVISIONS
3	10/25/21	LFS	UPDATE TO 2018 IRC/IRC
2	5/30/18	LFS	ADD FLAT FRAME LITE PROFILE
1	12/14/15	JK	ADD H.S. GLAZING OPTION

DATE: 6/13/13
SCALE: N.T.S.
DWG. BY: JK
CHK. BY: LFS
DRAWING NO.: TX-4332
SHEET 1 of 10

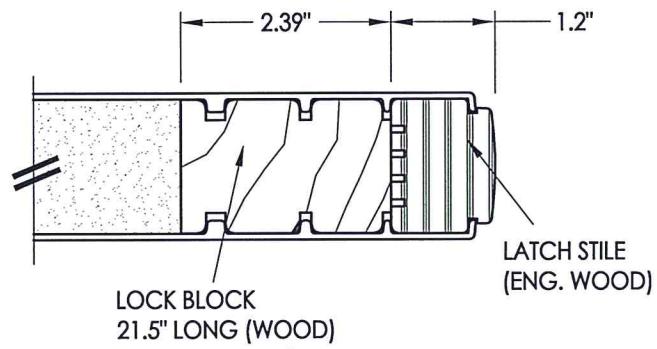
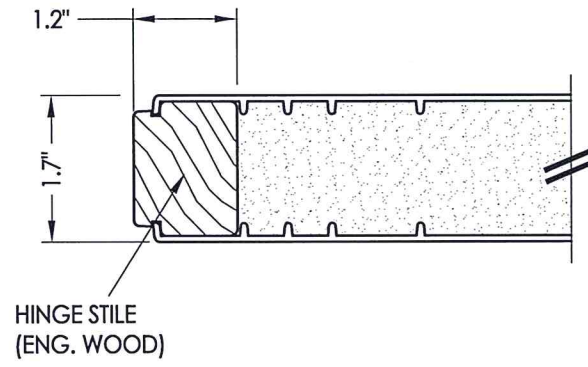

1
2 HORIZONTAL CROSS SECTION

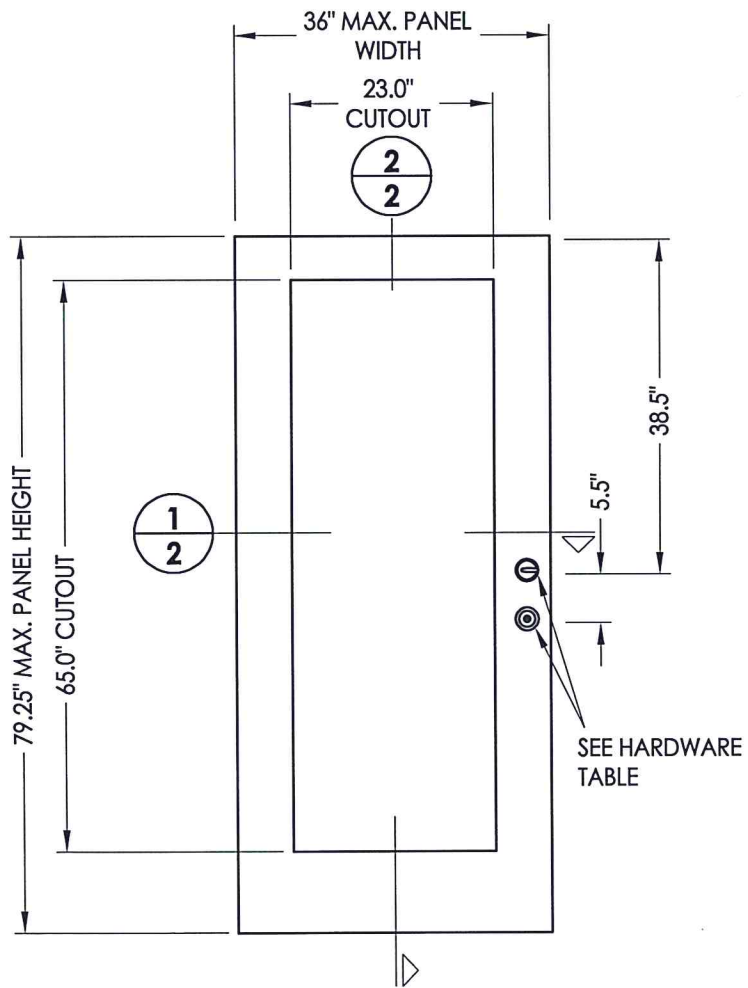

- 40** DOOR PANEL
Fiber Classic (Therma-Tru)
- 50** SIDELITE PANEL
Fiber Classic (Therma-Tru)

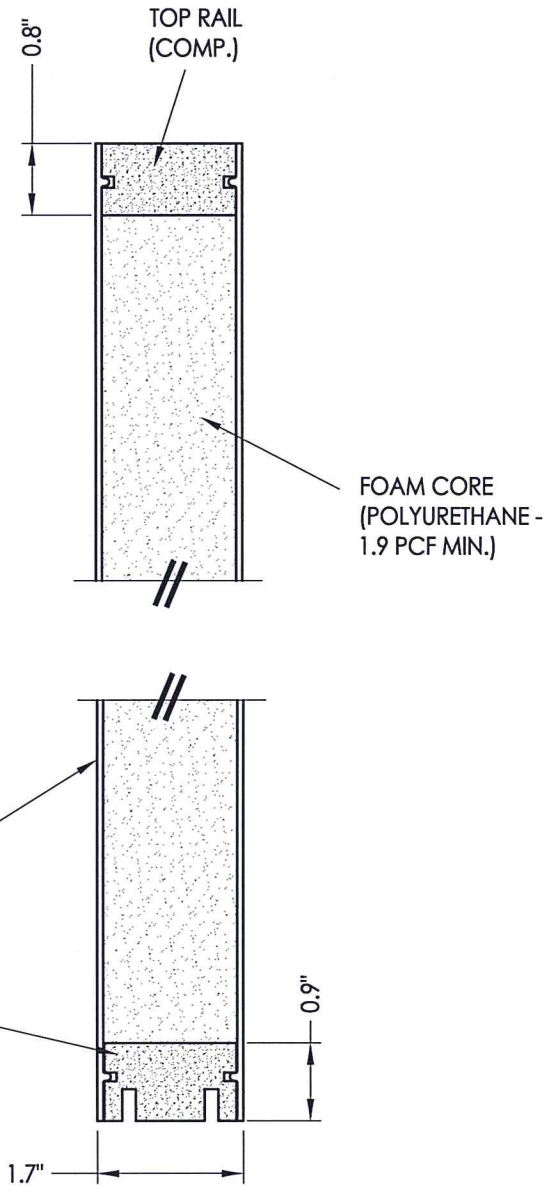

2
2 VERTICAL CROSS SECTION

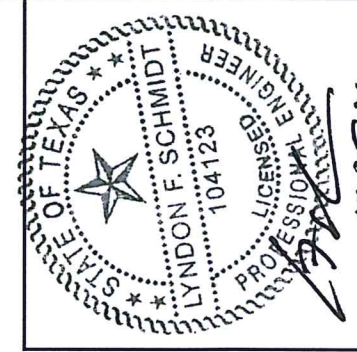

Documents Prepared By: Lyndon F. Schmidt, P.E.
TEXAS P.E. #104123

RW BUILDING CONSULTANTS, INC.

P.O. Box 230 Valrico FL 33595
Phone No.: 813.659.9197

TEXAS BOARD OF PROFESSIONAL ENGINEERS
CERTIFICATE OF REGISTRATION # F-11852

PRODUCT:		FIBERGLASS DOOR	
PART OR ASSEMBLY:		DOOR/SIDELITE PANEL DETAILS	
NO.	DATE	BY	REVISIONS
3	10/25/21	LFS	UPDATE TO 2018 IBC/IRC
2	5/30/18	LFS	ADD FLAT FRAME LITE PROFILE
1	12/14/15	JK	ADD H.S. GLAZING OPTION
DATE: 6/13/13			
SCALE: N.T.S.			
DWG. BY: JK			
CHK. BY: LFS			
DRAWING NO.: TX-4332			
SHEET 2 OF 10			

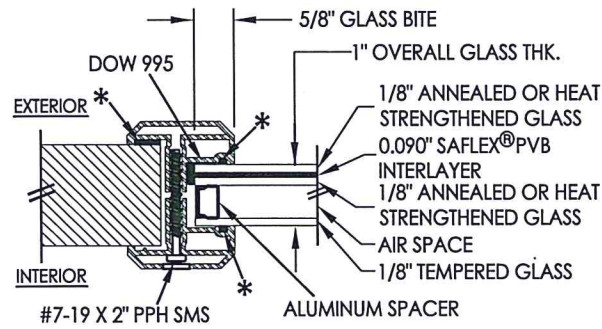

G1 GLAZING DETAIL
Flat Frame Profile

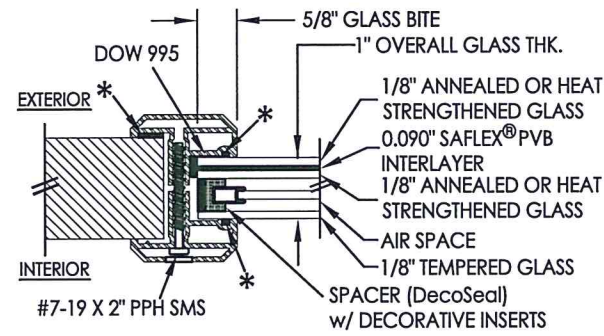

G3 GLAZING DETAIL
Flat Frame Profile

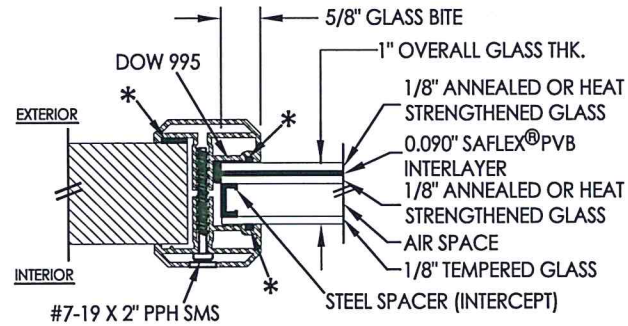

G2 GLAZING DETAIL
Flat Frame Profile

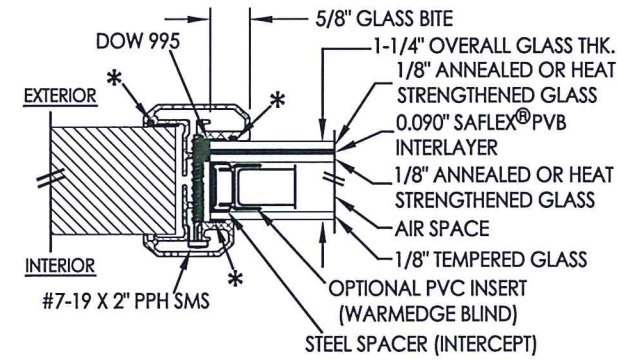

G4 GLAZING DETAIL
Flat Frame Profile
w/ Blinds Between Glass

* NON-STRUCTURAL
BACKBEDDING
(READI-SEAL)

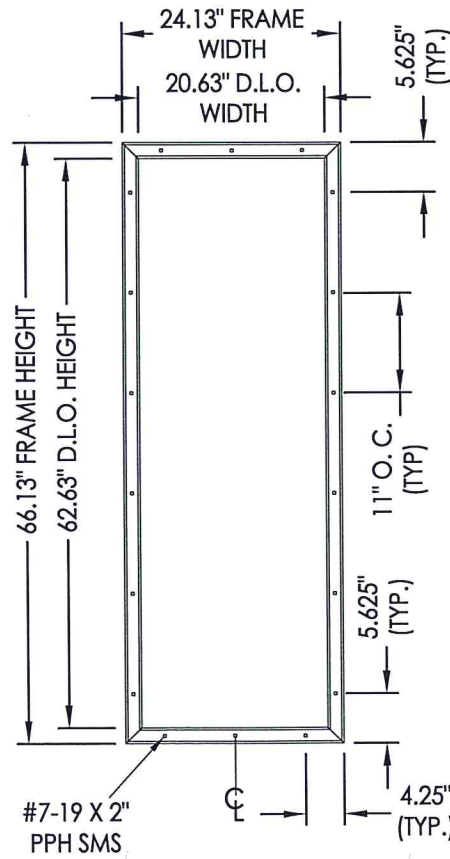

ODL LITE FRAME
"Flat Frame" Aluminum

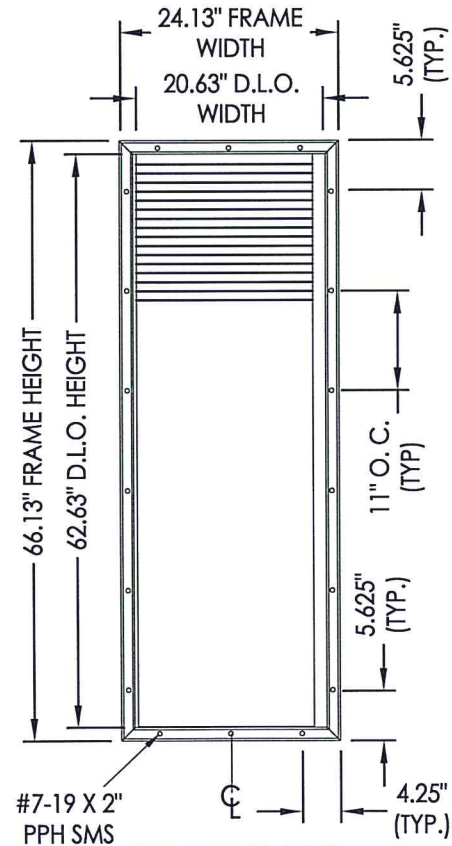

ODL LITE FRAME
"Flat Frame" Aluminum
w/ Blinds Between Glass

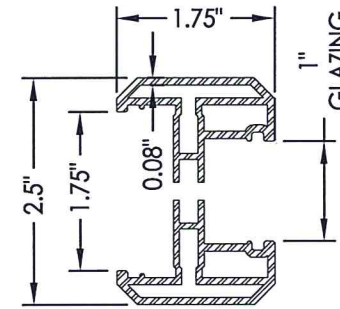

ODL LITE FLAT FRAME
1" GLAZING

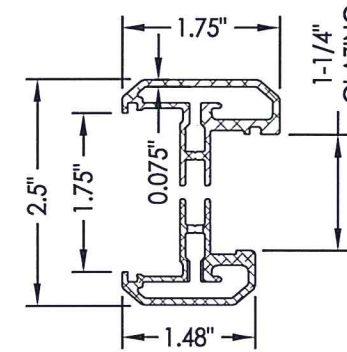

ODL LITE FLAT FRAME
1-1/4" GLAZING

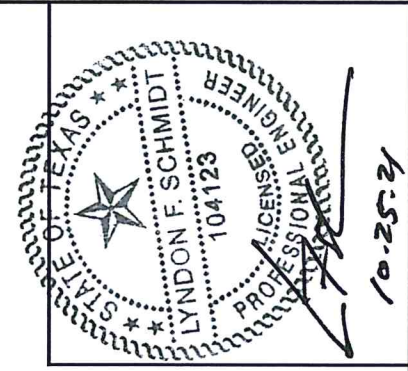

Documents Prepared By: Lyndon F. Schmidt, P.E.
TEXAS P.E. #104123

RW BUILDING CONSULTANTS, INC.
P.O. Box 230 Valrico FL 33595
Phone No.: 813.659.9197
TEXAS BOARD OF PROFESSIONAL ENGINEERS
CERTIFICATE OF REGISTRATION # F-11852

PRODUCT: FIBERGLASS DOOR
PART OR ASSEMBLY: LITE FRAME & GLAZING DETAILS

NO.	DATE	REVISIONS
3	10/25/21	UPDATE TO 2018 IBC/IRC
2	5/30/18	ADD FLAT FRAME LITE PROFILE
1	12/14/15	ADD H.S. GLAZING OPTION

DATE: 6/13/13
SCALE: N.T.S.
DWG. BY: JK
CHK. BY: LFS
DRAWING NO.: TX-4332
SHEET 3 OF 10

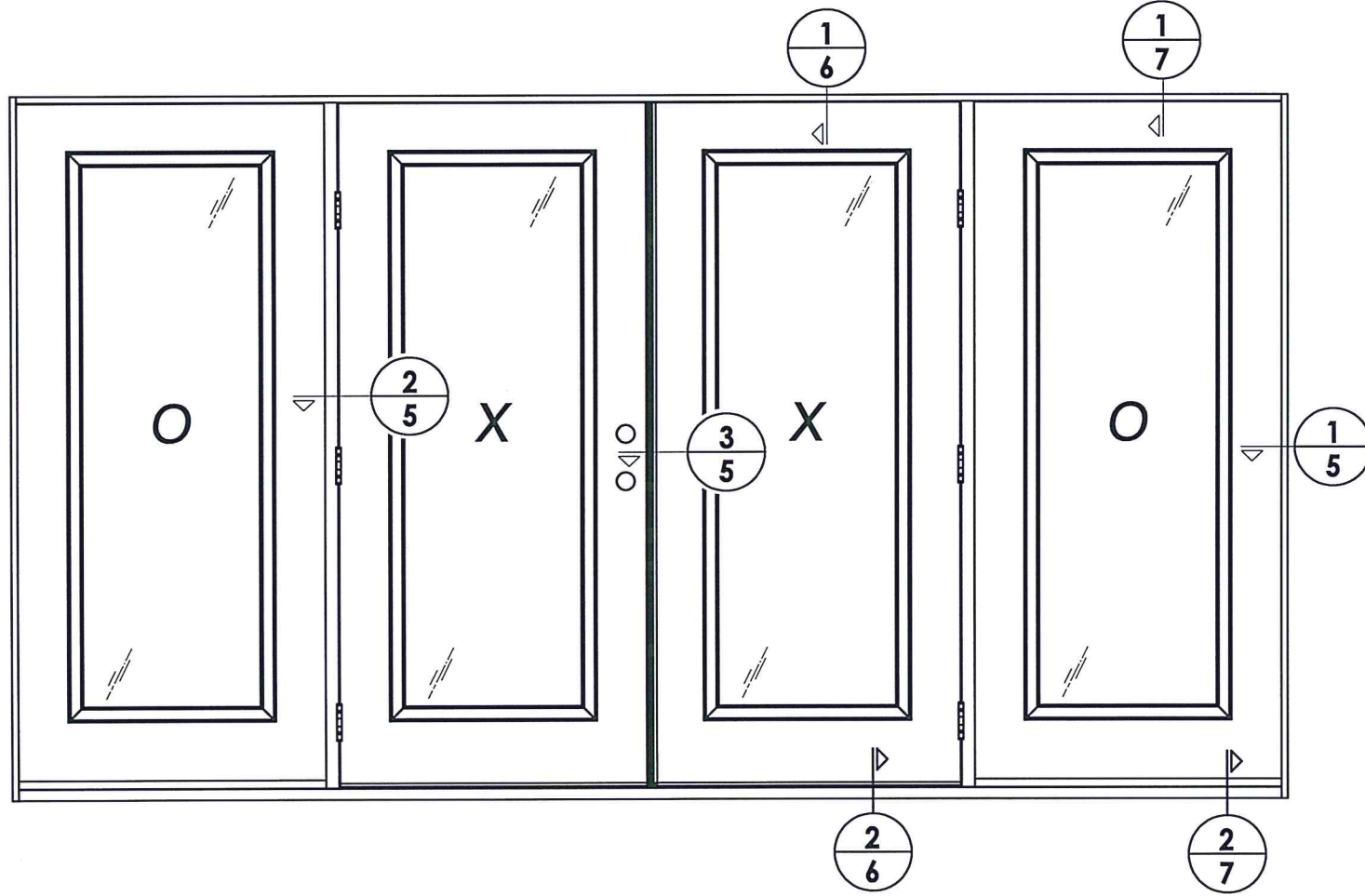

ELEVATION (OXXO)

HARDWARE TABLE		
MANUFACTURER	MODEL	
KWIKSET	KNOB:	SIGNATURE SERIES
	DEADBOLT:	SIGNATURE SERIES (980)
SCHLAGE	KNOB:	"F" SERIES (F60)
	DEADBOLT:	"B" SERIES (B60/62)
PAMEX*	KNOB:	"FT" SERIES
	DEADBOLT:	"FD7" SERIES

* MAX. DESIGN PRESSURE FOR PAMEX LOCK
INSWING = +40/-50 PSF

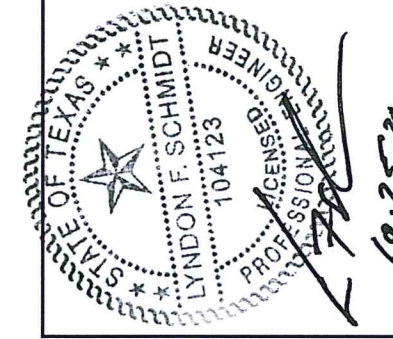

Documents Prepared By: Lyndon F. Schmidt, P.E.
TEXAS P.E. #104123

RW BUILDING CONSULTANTS, INC.
P.O. Box 230 Valrico FL, 33595
Phone No.: 813.659.9197

TEXAS BOARD OF PROFESSIONAL ENGINEERS
CERTIFICATE OF REGISTRATION # F-11852

PRODUCT:		FIBERGLASS DOOR	
PART OR ASSEMBLY:		ELEVATION & HARDWARE TABLE	
NO.	DATE	BY	REVISIONS
3	10/25/21	LFS	UPDATE TO 2018 IBC/IRC
2	5/30/18	LFS	ADD FLAT FRAME LITE PROFILE
1	12/14/15	JK	ADD H.S. GLAZING OPTION

DATE: 6/13/13
SCALE: N.T.S.
DWG. BY: JK
CHK. BY: LFS
DRAWING NO.: TX-4332
SHEET 4 OF 10

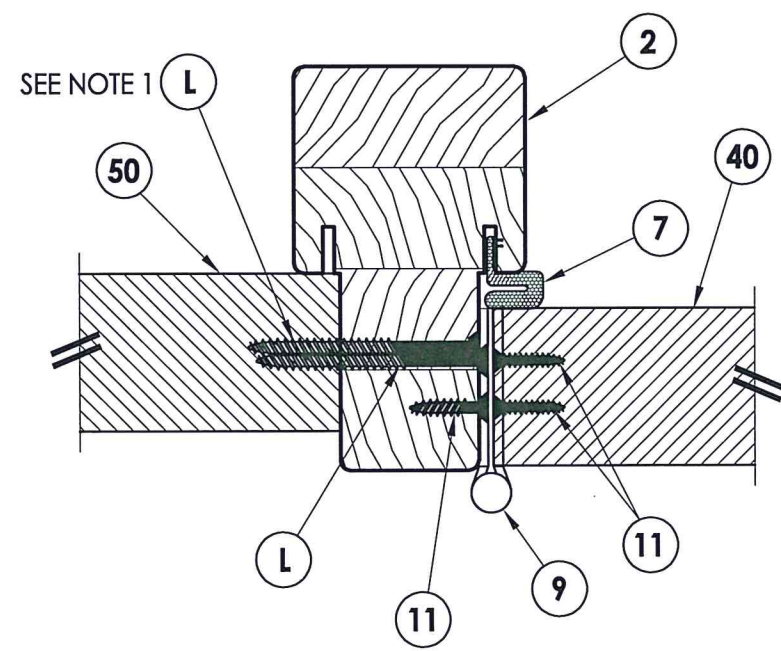

2 HORIZONTAL CROSS SECTION
5

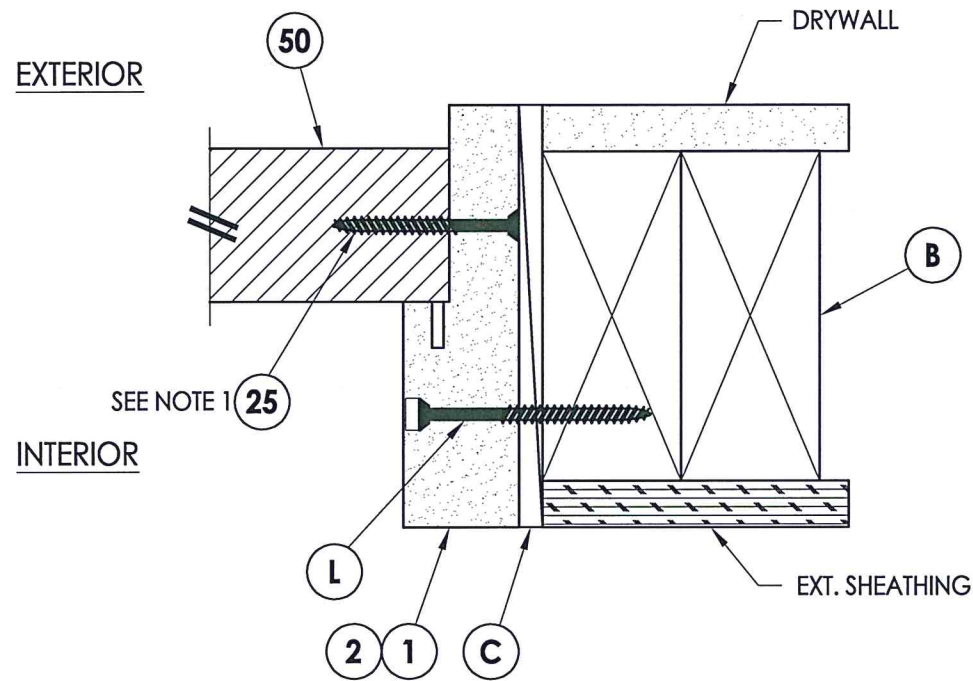

1 HORIZONTAL CROSS SECTION
5

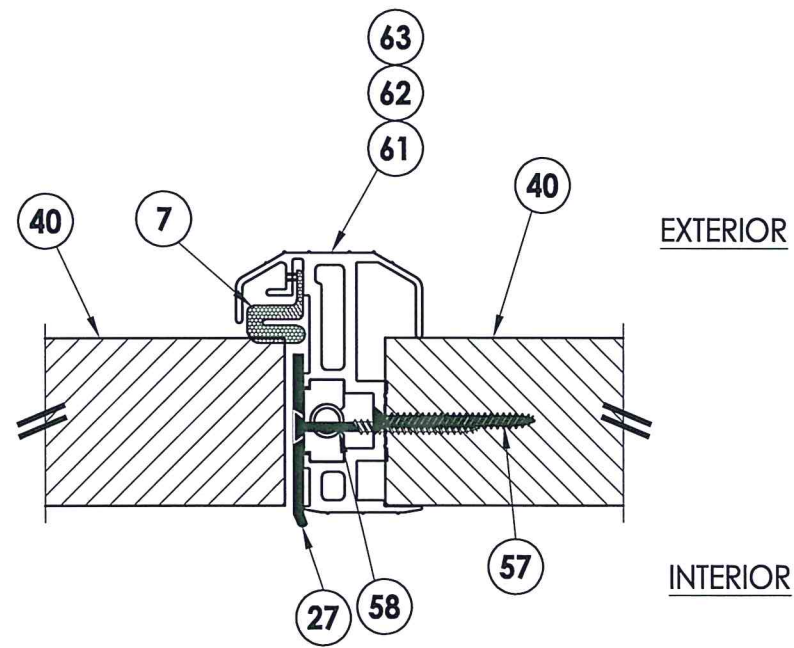

3 HORIZONTAL CROSS SECTION
5

NOTE:
1. Sidelite panel screws located 6" from each end plus 4 more equally spaced (6 screws total).

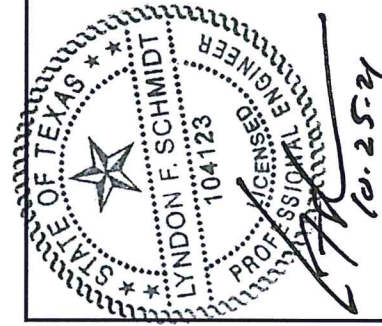

Documents Prepared By: Lyndon F. Schmidt, P.E.
TEXAS P.E. #104123

RW BUILDING CONSULTANTS, INC.
P.O. Box 230 Valrico FL, 33595
Phone No.: 813.659.9197
TEXAS BOARD OF PROFESSIONAL ENGINEERS
CERTIFICATE OF REGISTRATION # F-11852

PRODUCT: FIBERGLASS DOOR
PART OR ASSEMBLY: HORIZONTAL CROSS SECTIONS

NO.	DATE	BY
3	10/25/21	UPDATE TO 2018 IBC/IRC
2	5/30/18	ADD FLAT FRAME LITE PROFILE
1	12/14/15	ADD H.S. GLAZING OPTION

DATE: 6/13/13
SCALE: N.T.S.
DWG. BY: JK
CHK. BY: LFS
DRAWING NO.: TX-4332
SHEET 5 of 10

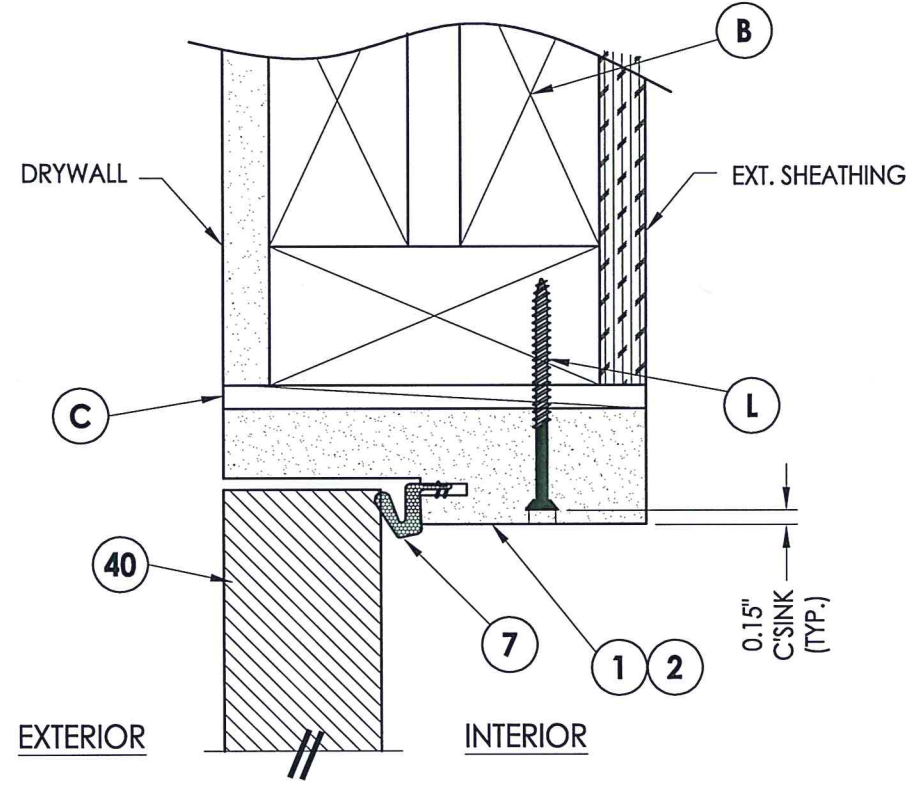

1
6 VERTICAL CROSS SECTION

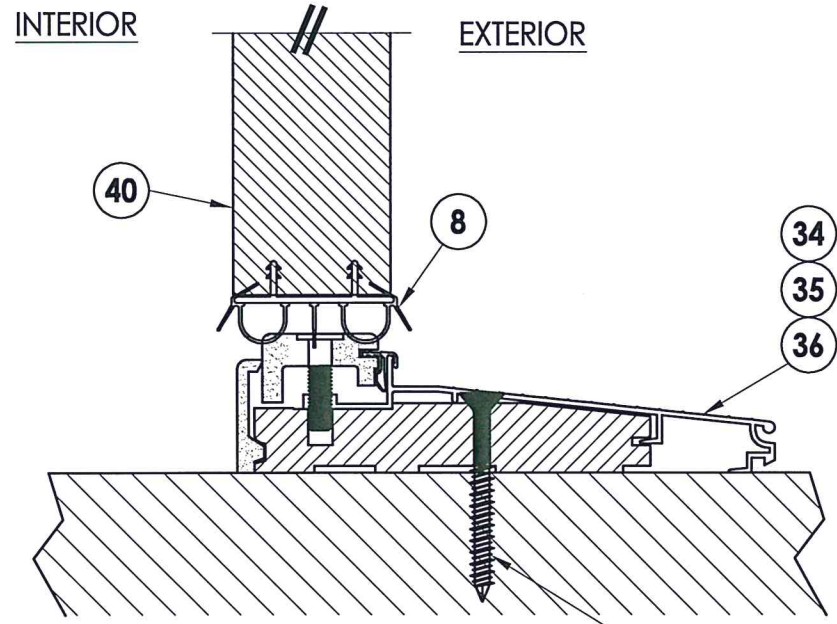

2
6 VERTICAL CROSS SECTION

J WOOD
D CONCRETE

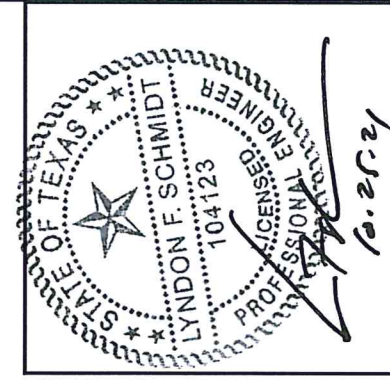

Documents Prepared By: Lyndon F. Schmidt, P.E.
TEXAS P.E. #104123

RW BUILDING CONSULTANTS, INC.
P.O. Box 230 Valrico FL, 33595
Phone No.: 813.659.9197
TEXAS BOARD OF PROFESSIONAL ENGINEERS
CERTIFICATE OF REGISTRATION # F-11852

PRODUCT:		FIBERGLASS DOOR	
PART OR ASSEMBLY:		VERTICAL CROSS SECTIONS	
NO.	DATE	NO.	DATE
3	10/25/21	3	10/25/21
2	5/30/18	2	5/30/18
1	12/14/15	1	12/14/15
DATE: 6/13/13		REVISIONS	
SCALE: N.T.S.			
DWG. BY: JK			
CHK. BY: LFS			
DRAWING NO.: TX-4332			
SHEET 6 OF 10			

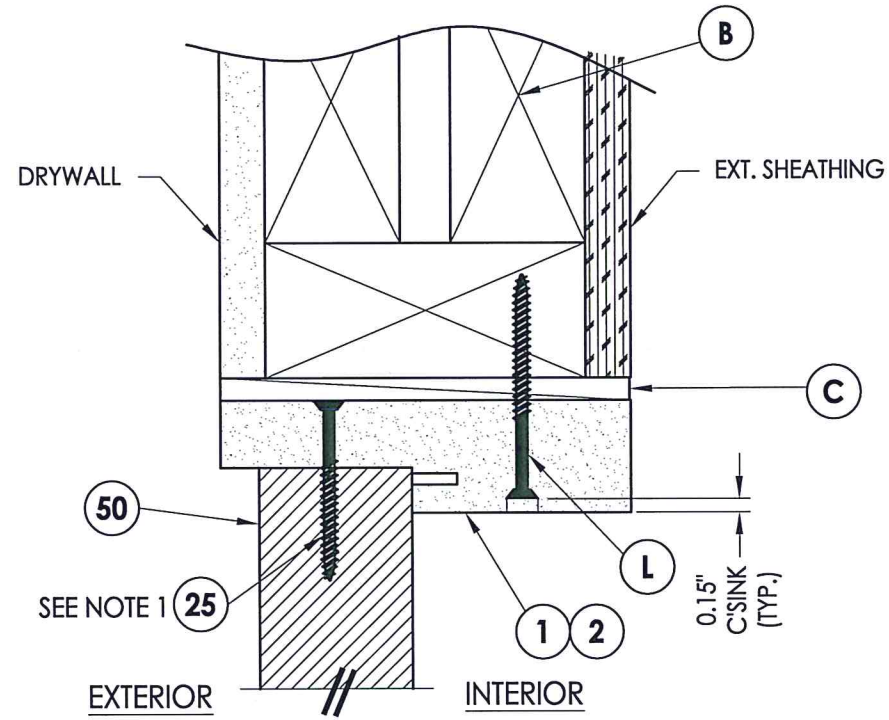

1
7 VERTICAL CROSS SECTION

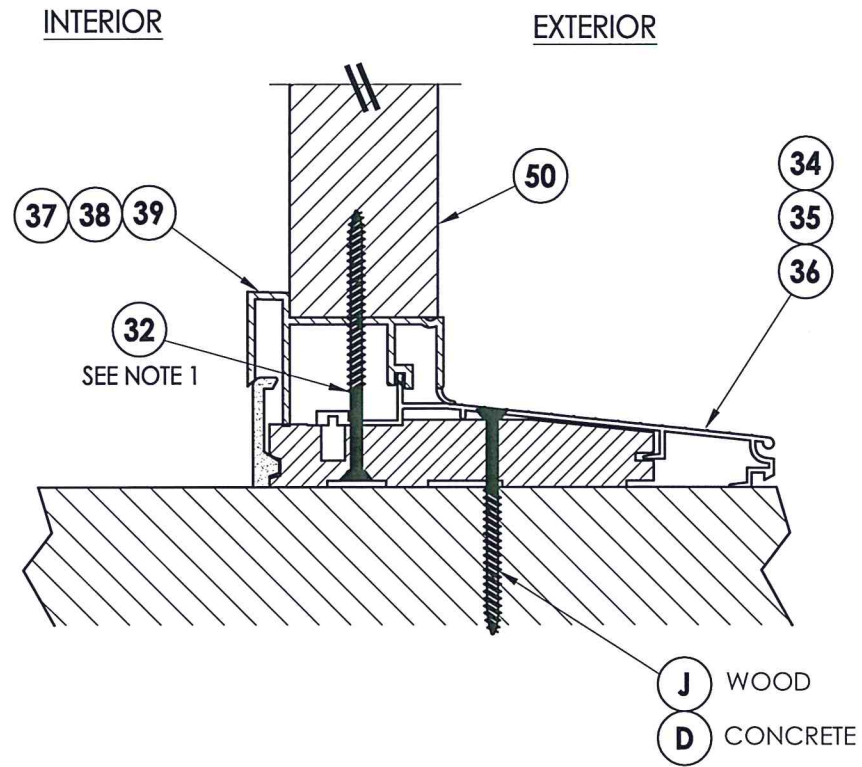

2
7 VERTICAL CROSS SECTION

NOTE:
1. Sidelite panel screws located 6" from each end (2 Total).

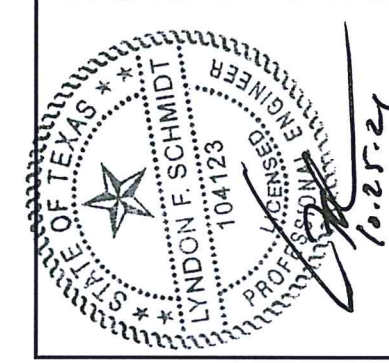

Documents Prepared By: Lyndon F. Schmidt, P.E.
TEXAS P.E. #104123

RW BUILDING CONSULTANTS, INC.
P.O. Box 230 Valrico FL 33595
Phone No.: 813.659.9197
TEXAS BOARD OF PROFESSIONAL ENGINEERS
CERTIFICATE OF REGISTRATION # F-11852

PRODUCT:		FIBERGLASS DOOR	
PART OR ASSEMBLY:		VERTICAL CROSS SECTIONS	
NO.	DATE	BY	REVISIONS
3	10/25/21	LFS	UPDATE TO 2018 IBC/IRC
2	5/30/18	LFS	ADD FLAT FRAME LITE PROFILE
1	12/14/15	JK	ADD H.S. GLAZING OPTION
DATE: 6/13/13			
SCALE: N.T.S.			
DWG. BY: JK			
CHK. BY: LFS			
DRAWING NO.: TX-4332			
SHEET 7 OF 10			

2X FRAMING TO BE DESIGNED BY THE ENGINEER OR ARCHITECT OF RECORD BASED ON WIND LOADS AND THE CLADDING BEING USED (TYP.).

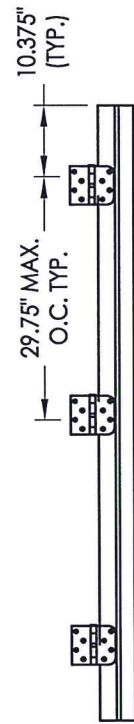

HINGE LOCATIONS

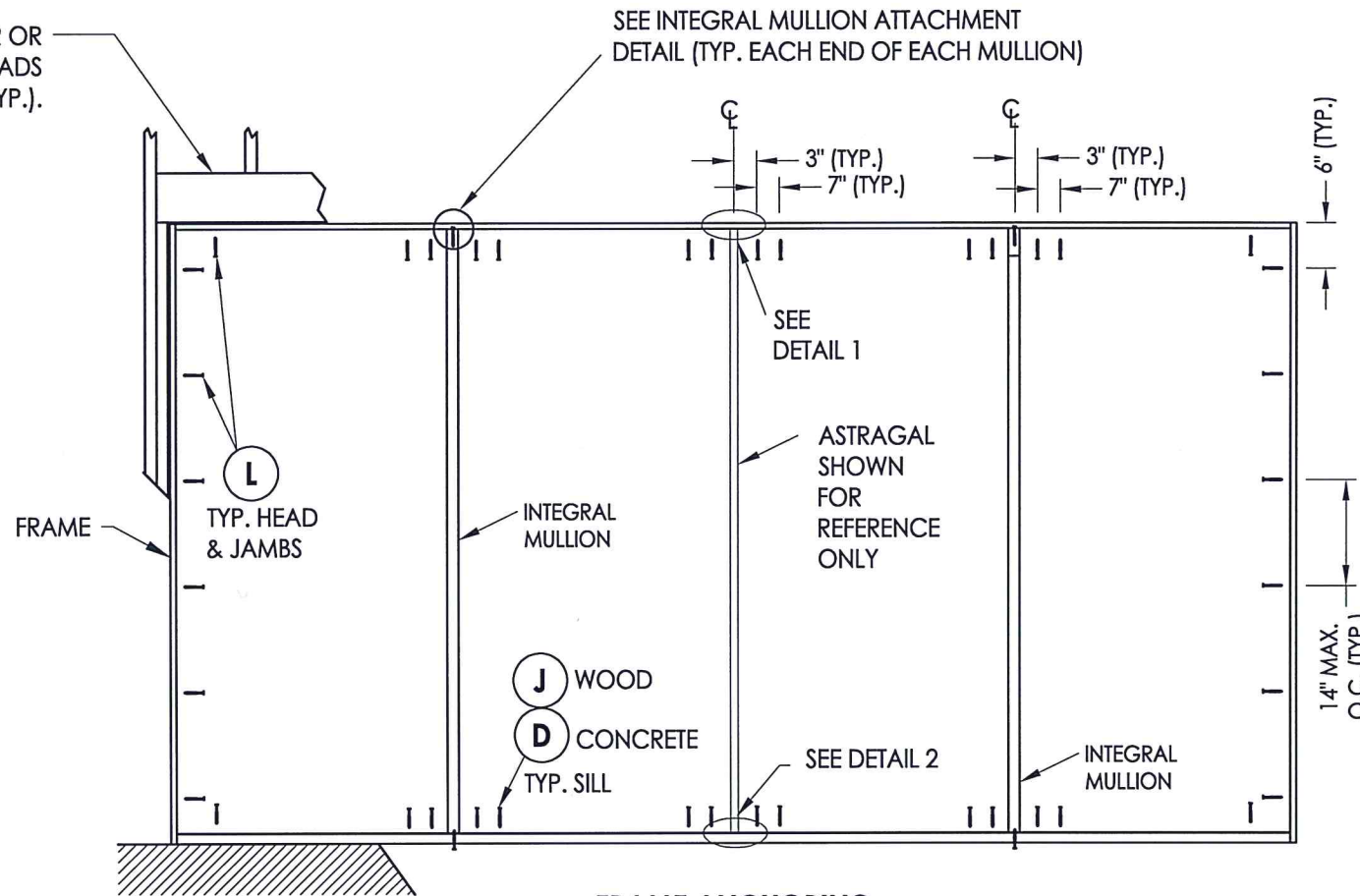

FRAME ANCHORING OXO

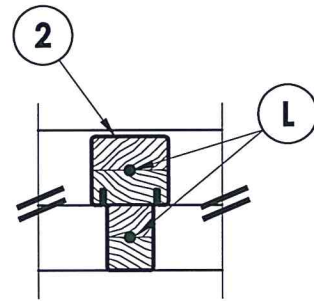

INTEGRAL MULLION ATTACHMENT DETAIL

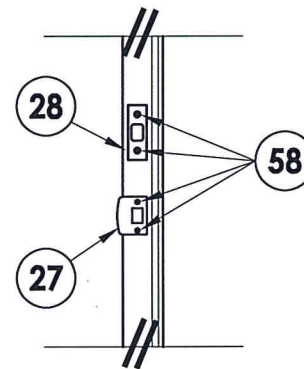

LATCH & DEAD BOLT DETAIL
Kwikset / Schlage / Pamex

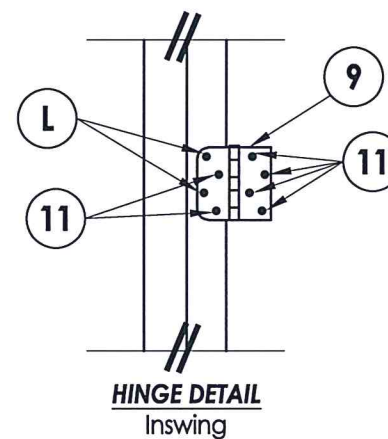

HINGE DETAIL
Inswing

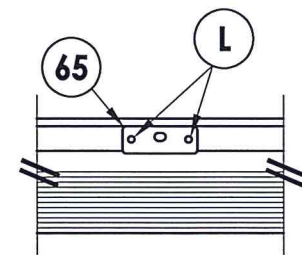

DETAIL 2
Astragal strike @ sill (inswing)

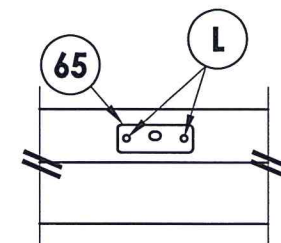

DETAIL 1
Astragal strike @ head

CONCRETE ANCHOR NOTES:

- Concrete anchor locations at the corners may be adjusted to maintain the min. edge distance to mortar joints.
- Concrete anchor locations noted as "MAX. ON CENTER" must be adjusted to maintain the min. edge distance to mortar joints, additional concrete anchors may be required to ensure the "MAX. ON CENTER" dimension are not exceeded.
- Concrete anchor table:

ANCHOR TYPE	ANCHOR SIZE	MIN. EMBEDMENT	MIN. CLEARANCE TO MASONRY EDGE	MIN. CLEARANCE TO ADJACENT ANCHOR
ITW TAPCON®	1/4"	1-3/4"	1-1/2"	4"
DeWALT ULTRACON®	1/4"	1-3/4"	1"	3"



Documents Prepared By: Lyndon F. Schmidt, P.E.
TEXAS P.E. #104123

RW BUILDING CONSULTANTS, INC.
P.O. Box 230 Vairico FL 33595
Phone No.: 813.659.9197
TEXAS BOARD OF PROFESSIONAL ENGINEERS
CERTIFICATE OF REGISTRATION # F-11852

PRODUCT: FIBERGLASS DOOR
PART OR ASSEMBLY: FRAME ANCHORING

NO.	DATE	REVISIONS
3	10/25/21	UPDATE TO 2018 IBC/IRC
2	5/30/18	ADD FLAT FRAME LITE PROFILE
1	12/14/15	ADD H.S. GLAZING OPTION
		NO. DATE
		BY

DATE: 6/13/13
SCALE: N.T.S.
DWG. BY: JK
CHK. BY: LFS
DRAWING NO.: TX-4332
SHEET 8 OF 10

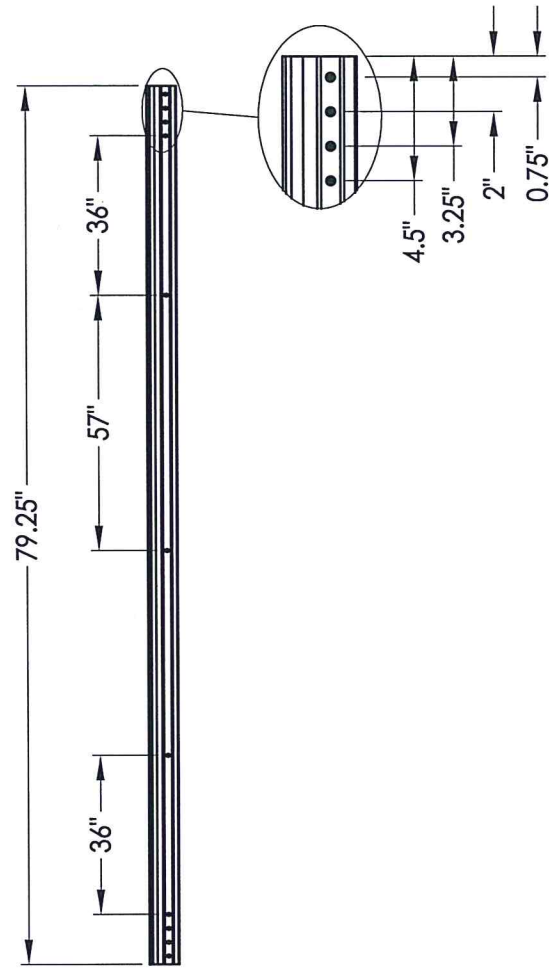

ASTRAGAL SCREW LOCATIONS

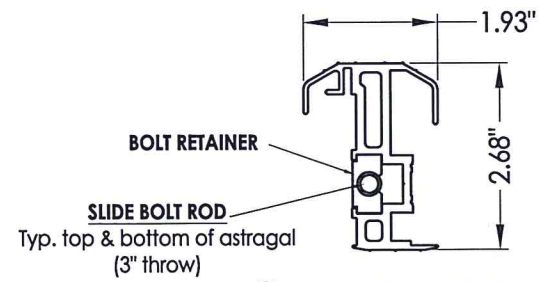

61 ALUMINUM ASTRAGAL
Therma-Tru

6'8 ALUMINUM ASTRAGAL ASSEMBLY
Therma-Tru

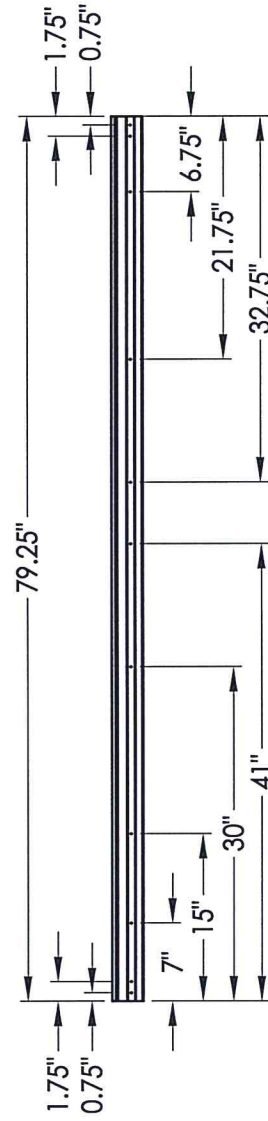

ASTRAGAL SCREW LOCATIONS

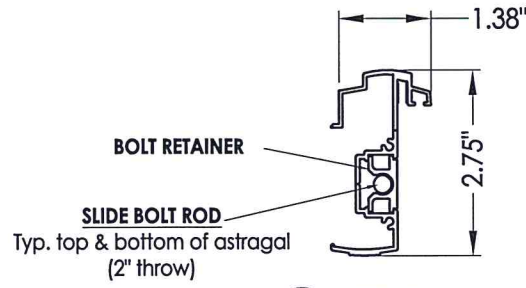

62 ASTRAGAL
Columbia

6'8 ALUMINUM ASTRAGAL ASSEMBLY
Columbia

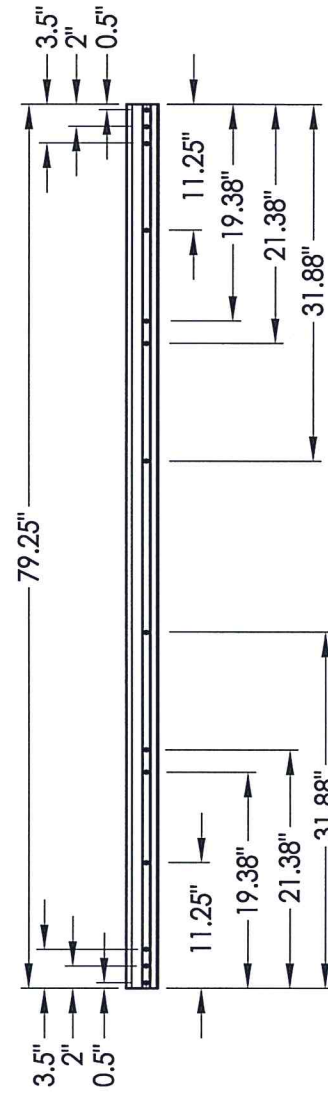

ASTRAGAL SCREW LOCATIONS

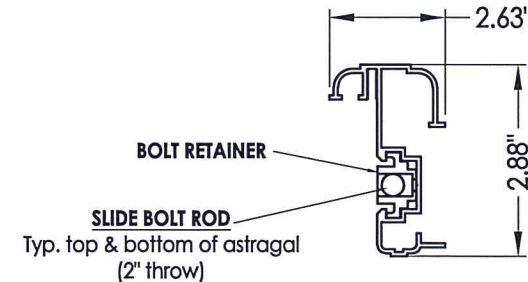

63 ASTRAGAL
DLP

6'8 ALUMINUM ASTRAGAL ASSEMBLY
DLP



Documents Prepared By: Lyndon F. Schmidt, P.E.
TEXAS P.E. #104123

RW BUILDING CONSULTANTS, INC.
P.O. Box 230 Vairico FL 33595
Phone No.: 813.659.9197
TEXAS BOARD OF PROFESSIONAL ENGINEERS
CERTIFICATE OF REGISTRATION # F-11852

PRODUCT:		FIBERGLASS DOOR	
PART OR ASSEMBLY:		ASTRAGAL DETAILS	
NO.	DATE	BY	REVISIONS
3	10/25/21	LFS	UPDATE TO 2018 IBC/IRC
2	5/30/18	LFS	ADD FLAT FRAME LITE PROFILE
1	12/14/15	JK	ADD H.S. GLAZING OPTION
DATE: 6/13/13			
SCALE: N.T.S.			
DWG. BY: JK			
CHK. BY: LFS			
DRAWING NO.: TX-4332			
SHEET 9 OF 10			

BILL OF MATERIALS

ITEM #	DESCRIPTION	MATERIAL
B	2X FRAMING (G >= 0.42)	WOOD
C	1/4" MAX. SHIM SPACE	-
D	1/4" PFH DeWALT OR ITW CONCRETE SCREW (1-3/4" MIN. EMB.)	STEEL
J	#10 X 3" PFH WOOD SCREW (1-1/2" MIN. EMB.)	STEEL
L	#10 X 2-1/2" PFH WOOD SCREW (1.15" MIN. EMB.)	STEEL
1	HEAD & JAMB	WOOD
2	HEAD & JAMB	COMP
7	WEATHERSTRIP	FOAM
8	DOOR BOTTOM SWEEP	VINYL
9	4" x 4" HINGE	STEEL
11	#9 X 3/4" PFH WOOD SCREW	STEEL
24	#10 X 1-1/2" PFH WOOD SCREW	STEEL
25	#10 X 2" PFH WOOD SCREW	STEEL
27	LATCH STRIKE PLATE	STEEL
28	DEADBOLT STRIKE PLATE	STEEL
32	#8 X 3" PFH WS	STEEL
34	INSWING THRESHOLD	ALUM/COMP
35	INSWING THRESHOLD	ALUM/COMP
36	INSWING THRESHOLD	ALUM/COMP
37	INSWING SIDELITE SEAT	PVC
38	INSWING SIDELITE SEAT	PVC
39	INSWING SIDELITE SEAT	PVC
40	DOOR PANEL - SEE DOOR PANEL DETAIL SHEET FOR DETAILS	-
50	SIDELITE PANEL - SEE SIDELITE PANEL DETAIL SHEET FOR DETAILS	-
57	#8 X 2" PPH SMS	STEEL
58	#8 X 2-1/2" PFH WOOD SCREW	STEEL
61	ASTRAGAL (THERMA-TRU)	ALUM
62	ASTRAGAL (COLUMBIA)	ALUM
63	ASTRAGAL (DLP)	ALUM
65	ASTRAGAL STRIKE PLATE	STEEL

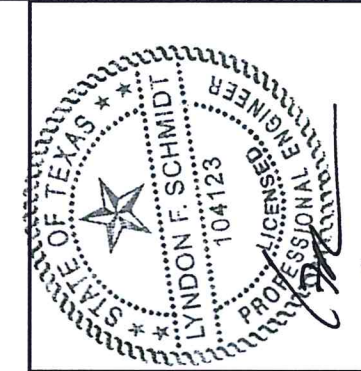

Documents Prepared By: Lyndon F. Schmidt, P.E.
TEXAS P.E. #104123

RW BUILDING CONSULTANTS, INC.
P.O. Box 230 Vairico FL, 33595
Phone No.: 813.659.9197

TEXAS BOARD OF PROFESSIONAL ENGINEERS
CERTIFICATE OF REGISTRATION # F-11852

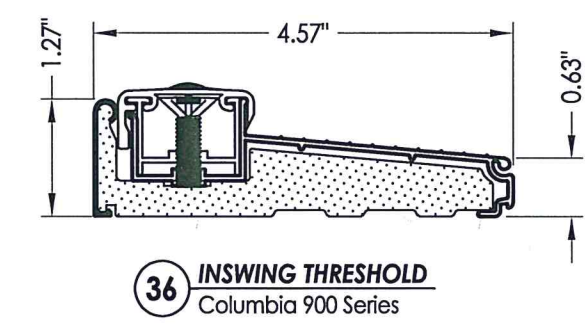
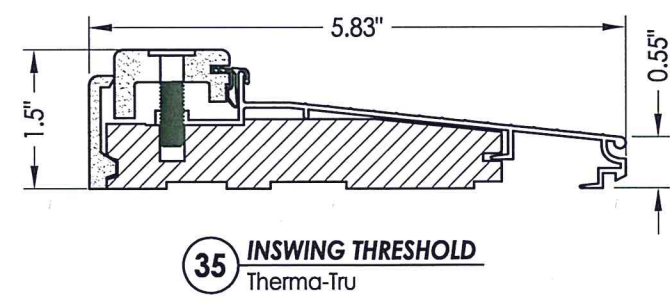
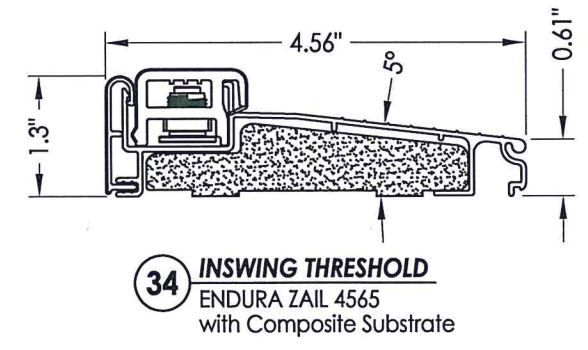
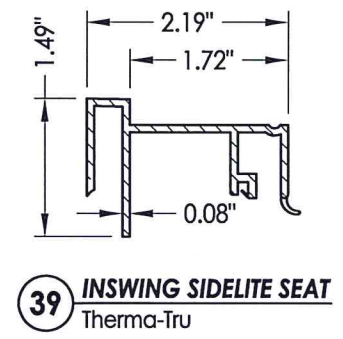
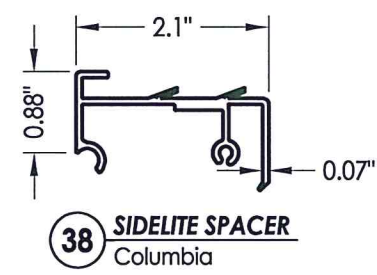
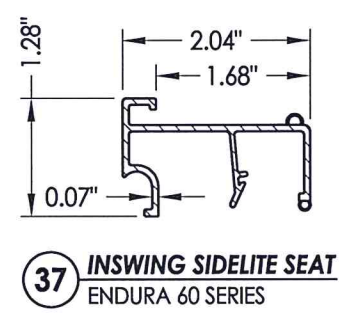
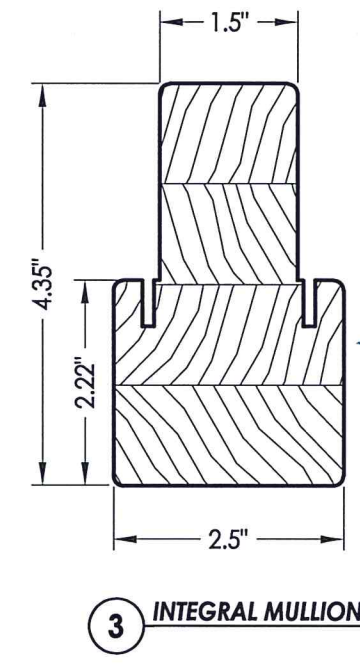
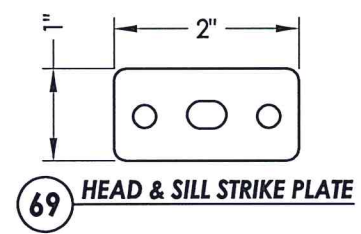
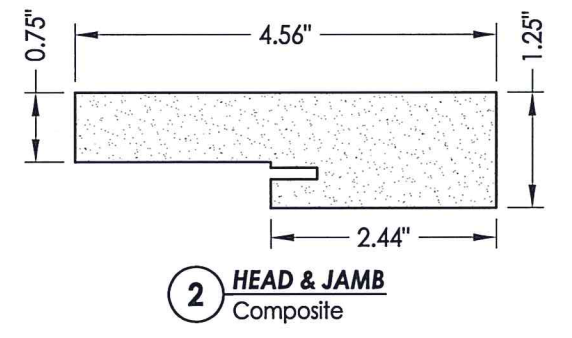
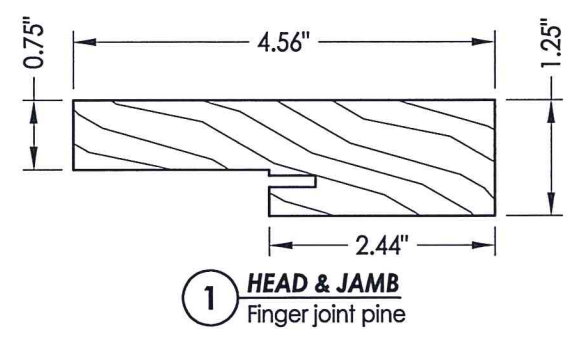

PRODUCT: FIBERGLASS DOOR

PART OR ASSEMBLY: BILL OF MATERIALS & COMPONENTS

NO.	DATE	REVISIONS
3	10/25/21	UPDATE TO 2018 IBC/IRC
2	5/30/18	ADD FLAT FRAME LITE PROFILE
1	12/14/15	ADD H.S. GLAZING OPTION

DATE: 6/13/13

SCALE: N.T.S.

DWG. BY: JK

CHK. BY: LFS

DRAWING NO.: TX-4332

SHEET 10 OF 10