

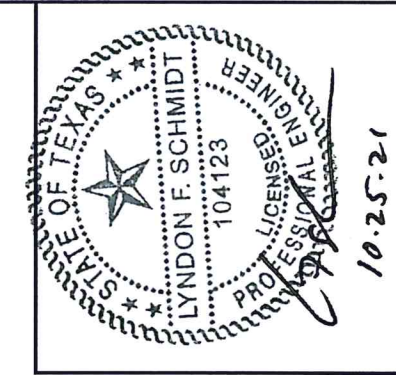

215 EAST ROOSEVELT AVE.
ZEELAND, MI 49464



Documents Prepared By: Lyndon F. Schmidt, P.E.
TEXAS P.E. #104123

RW BUILDING CONSULTANTS, INC.
P.O. Box 230 Vairico FL 33595
Phone No.: 813.659.9197
TEXAS BOARD OF PROFESSIONAL ENGINEERS
CERTIFICATE OF REGISTRATION # F-11852

FIBERGLASS ENTRY DOOR IN SWING "IMPACT"

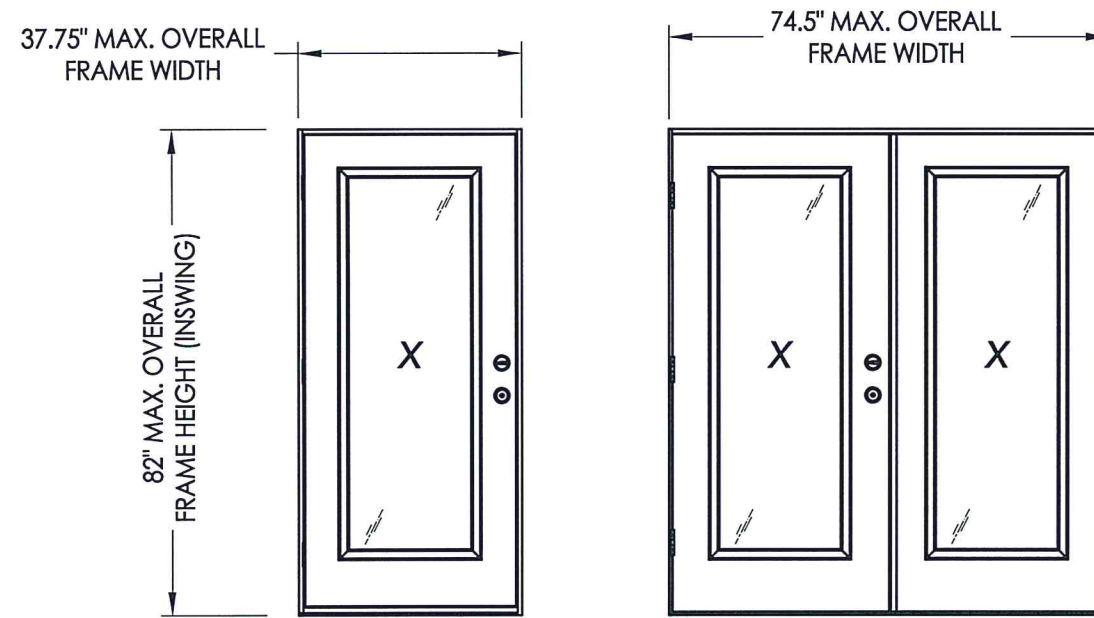

EVALUATED FOR USE IN THE STATE OF TEXAS

TDI DR-691

The Fiberglass Door system described herein complies with the 2018 International Residential Code (IRC), Sections R301 & R609 and the 2018 International Building Code (IBC), Sections 1404.13, 1609, 1709.5, 2403 and 2404 subject to the following conditions:

1. Anchors shall be as listed and spaced as shown in the details. Anchor embedment to base material shall be beyond wall dressing or stucco.
2. This system has been tested and evaluated as a large missile impact protective system for installation in areas that require wind borne debris protection. This product meets missile level "D" as defined in ASTM E 1996.
3. Allowable design pressure requirements must be equal to or less than the design pressure rating shown in the design pressure chart, sheet 1 of this drawing.
4. Conditions not covered by this drawing are subject to further engineering analysis.
5. Fiber-Classic and Smooth-Star Door panels require the use of "J" part numbers. These door panels must be stained or painted within six months of installation.

TABLE OF CONTENTS

SHEET #	DESCRIPTION
1	Typical elevations, design pressures & general notes
2	Door panel details
3	Lite frame and glazing details
4	Elevations & hardware table
5	Horizontal cross sections
6	Vertical cross sections
7	Frame anchoring
8	Astragal details
9	Bill of materials & components

CONFIGURATION	MAX. FRAME DIMENSION	DESIGN PRESSURE (PSF) INSWING	
		POSITIVE	NEGATIVE
X	37.75" x 82.0"	+45.0	-50.0
XX	74.5" x 82.0"	+45.0	-50.0

PRODUCT: FIBERGLASS DOOR
PART OR ASSEMBLY: TYPICAL ELEVATION, DESIGN PRESSURES & GENERAL NOTES

NO.	DATE	REVISIONS
3	10/25/21	UPDATE TO 2018 IRC/IBC
2	5/30/18	ADD FLAT FRAME LITE PROFILE
1	12/14/15	ADD H.S. GLAZING OPTION

DATE: 6/13/13
SCALE: N.T.S.
DWG. BY: JK
CHK. BY: LFS
DRAWING NO.: TX-4329
SHEET 1 OF 9

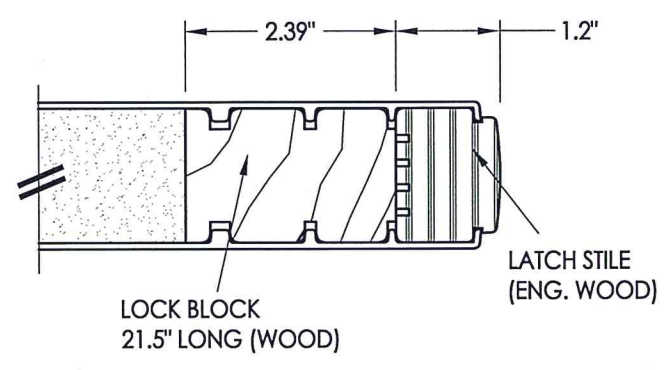
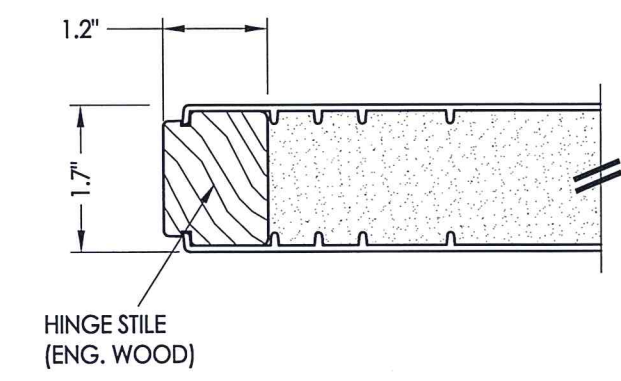

1
2 HORIZONTAL CROSS SECTION

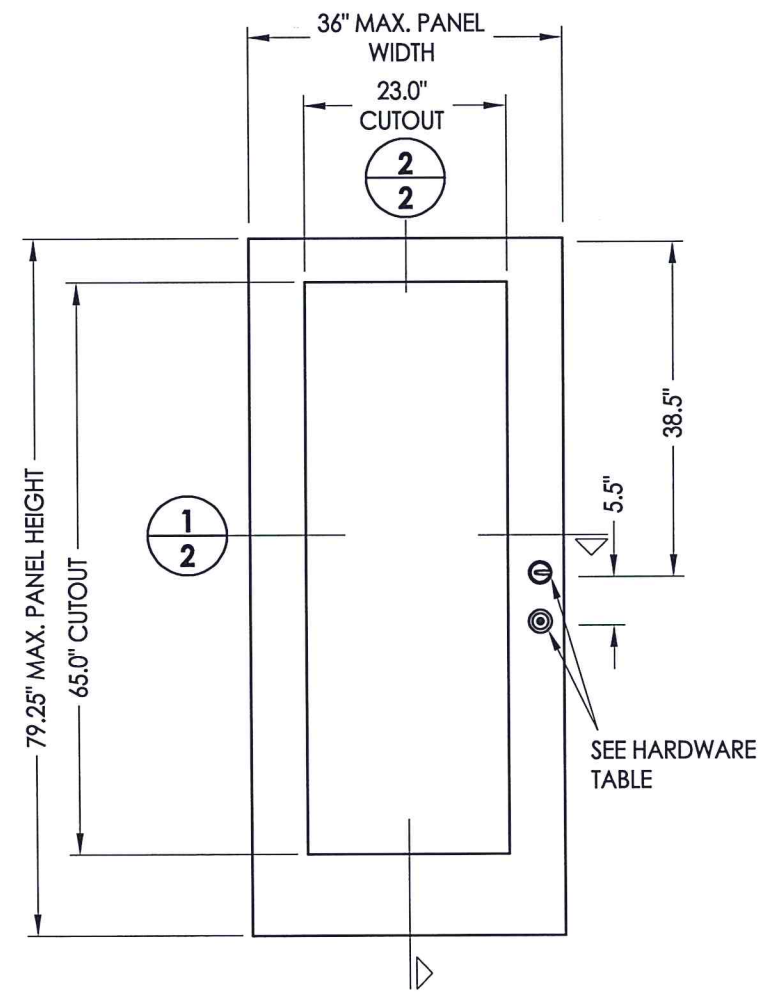

40 DOOR PANEL
Fiber Classic (Therma-Tru)

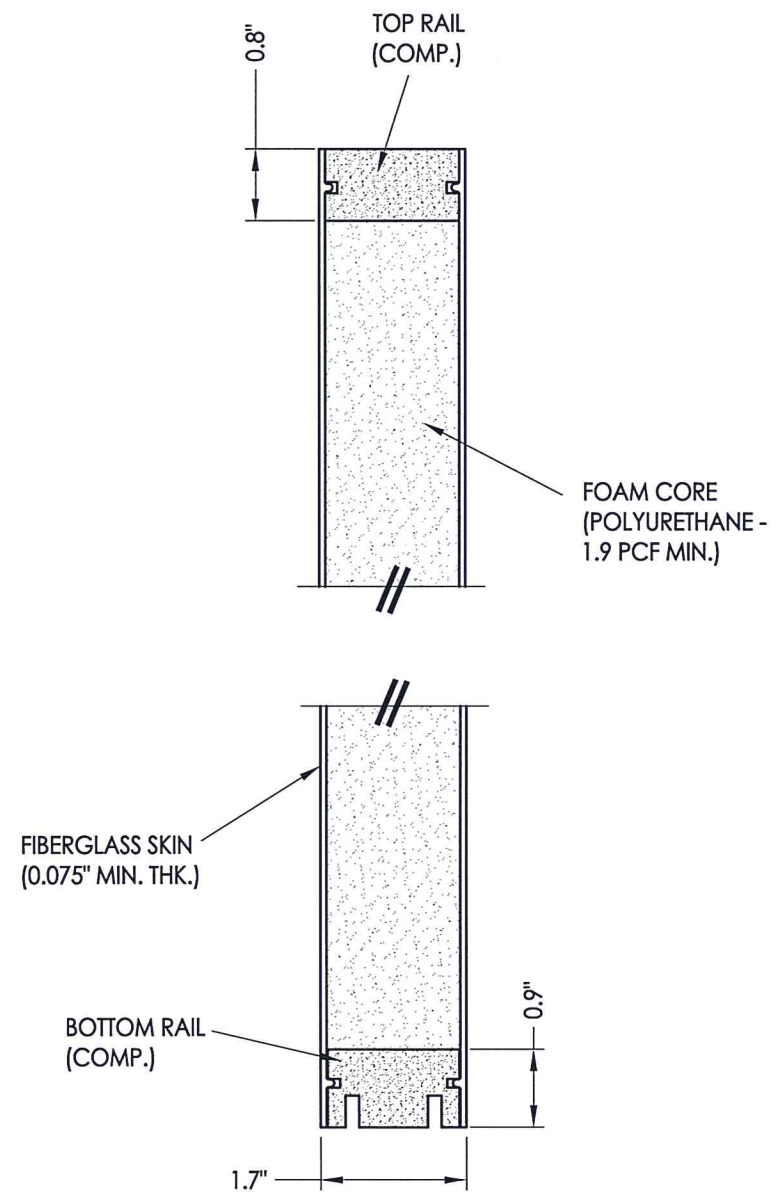

2
2 VERTICAL CROSS SECTION



Documents Prepared By: Lyndon F. Schmidt, P.E.
TEXAS P.E. #104123

RW BUILDING CONSULTANTS, INC.
P.O. Box 230 Valrico FL 33595
Phone No.: 813.659.9197

TEXAS BOARD OF PROFESSIONAL ENGINEERS
CERTIFICATE OF REGISTRATION # F-11852

PRODUCT:	FIBERGLASS DOOR
PART OR ASSEMBLY:	DOOR/SIDELITE PANEL DETAILS

NO.	DATE	BY	REVISIONS
3	10/25/21	LFS	UPDATE TO 2018 IBC/IRC
2	5/30/18	LFS	ADD FLAT FRAME LITE PROFILE
1	12/14/15	JK	ADD H.S. GLAZING OPTION

DATE: 6/13/13
SCALE: N.T.S.
DWG. BY: JK
CHK. BY: LFS
DRAWING NO.: TX-4329
SHEET 2 OF 9

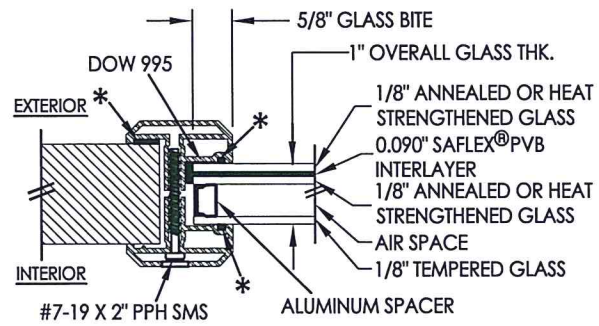

G1 GLAZING DETAIL
Flat Frame Profile

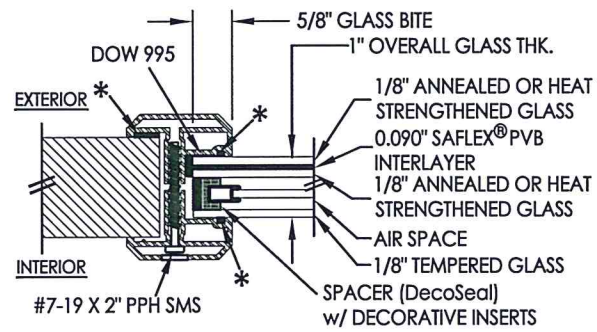

G3 GLAZING DETAIL
Flat Frame Profile

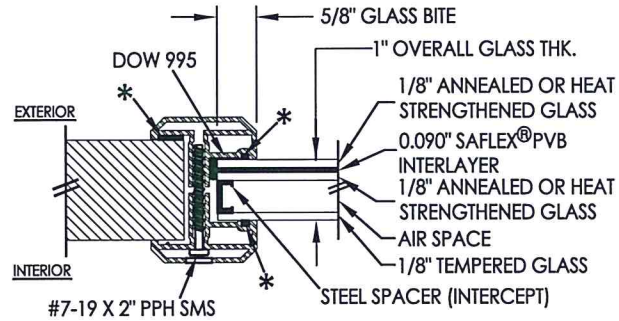

G2 GLAZING DETAIL
Flat Frame Profile

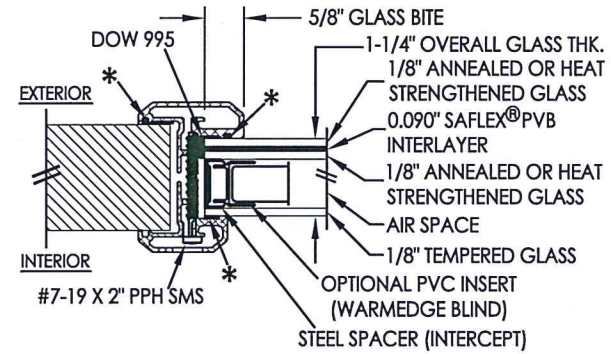

G4 GLAZING DETAIL
Flat Frame Profile
w/ Blinds Between Glass

* NON-STRUCTURAL
BACKBEDDING
(READI-SEAL)

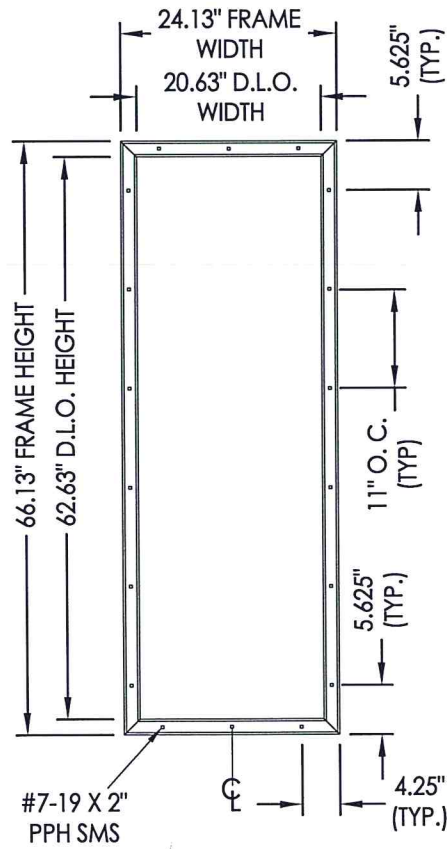

ODL LITE FRAME
"Flat Frame" Aluminum

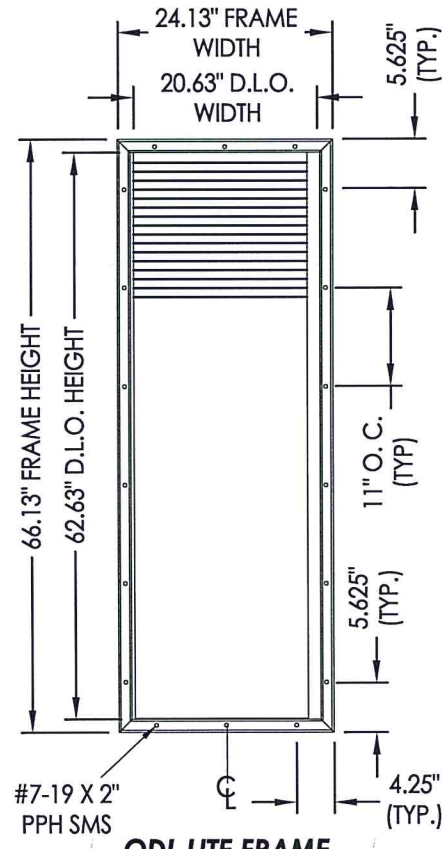

ODL LITE FRAME
"Flat Frame" Aluminum
w/ Blinds Between Glass

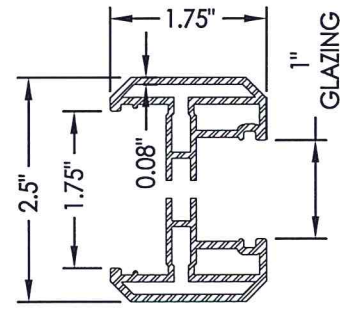

ODL LITE FLAT FRAME
1" GLAZING

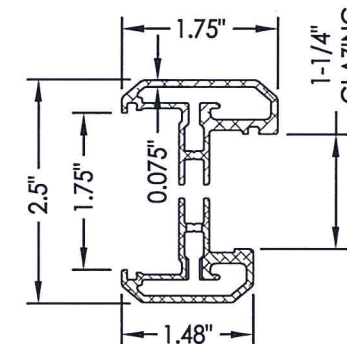

ODL LITE FLAT FRAME
1-1/4" GLAZING

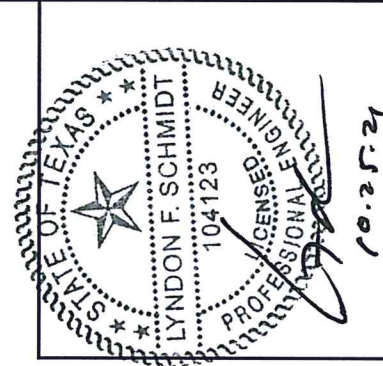

Documents Prepared By: Lyndon F. Schmidt, P.E.
TEXAS P.E. #104123

RW BUILDING CONSULTANTS, INC.
P.O. Box 230 Valrico FL 33595
Phone No.: 813.659.9197

TEXAS BOARD OF PROFESSIONAL ENGINEERS
CERTIFICATE OF REGISTRATION # F-11852

PRODUCT: FIBERGLASS DOOR

PART OR ASSEMBLY: LITE FRAME & GLAZING DETAILS

NO.	DATE	REVISIONS
3	10/25/21	UPDATE TO 2018 IBC/IRC
2	5/30/18	ADD FLAT FRAME LITE PROFILE
1	12/14/15	ADD H.S. GLAZING OPTION

DATE: 6/13/13

SCALE: N.T.S.

DWG. BY: JK

CHK. BY: LFS

DRAWING NO.:

TX-4329

SHEET 3 OF 9

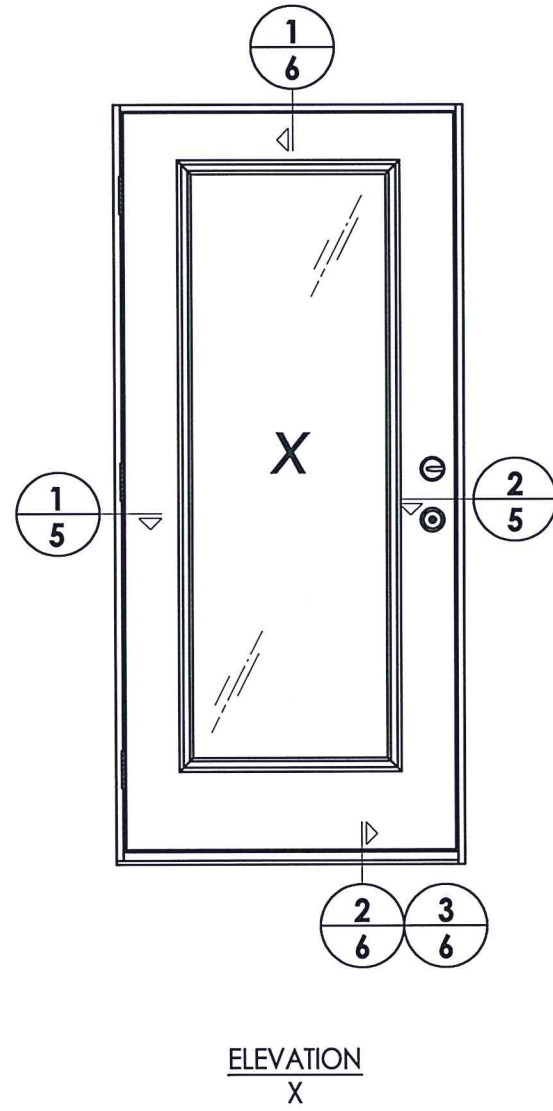

HARDWARE TABLE		
MANUFACTURER	MODEL	
KWIKSET	KNOB:	SIGNATURE SERIES
	DEADBOLT:	SIGNATURE SERIES (980)
SCHLAGE	KNOB:	"F" SERIES (F60)
	DEADBOLT:	"B" SERIES (B60/62)
PAMEX*	KNOB:	"FT" SERIES
	DEADBOLT:	"FD7" SERIES

* MAX. DESIGN PRESSURE FOR PAMEX LOCK
INSWING = +40/-50 PSF

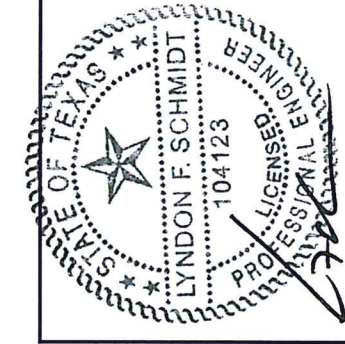
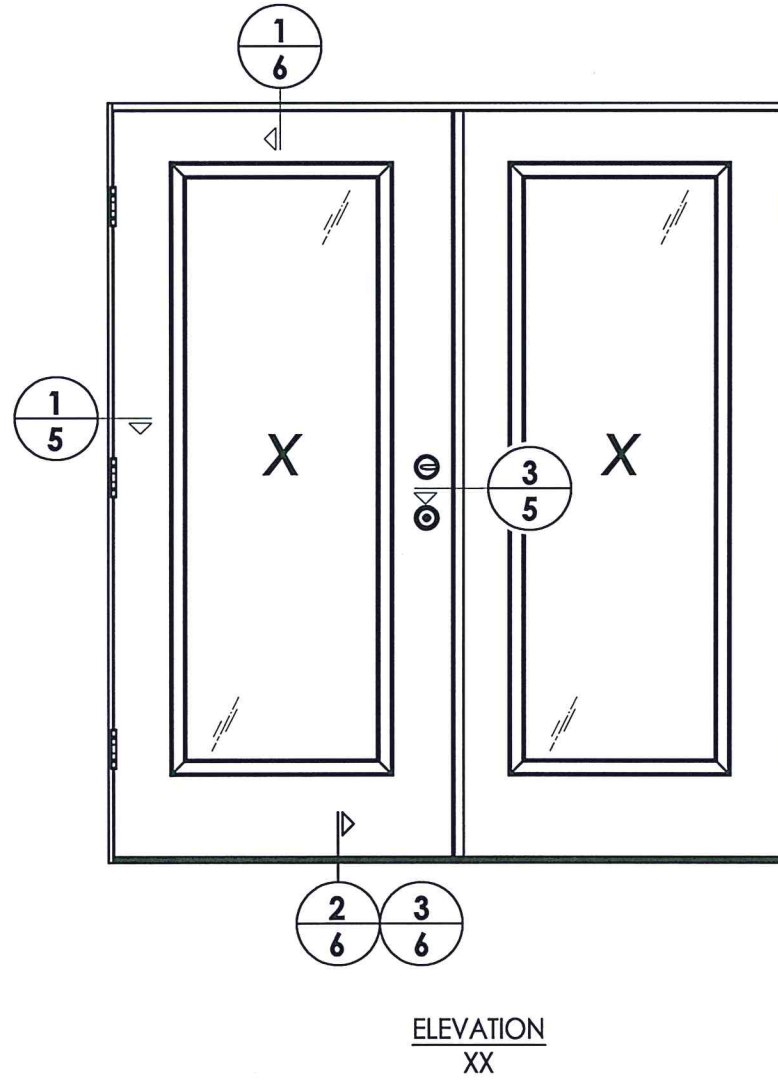

Documents Prepared By: Lyndon F. Schmidt, P.E.
TEXAS P.E. #104123

RW BUILDING CONSULTANTS, INC.
P.O. Box 230 Valrico FL 33595
Phone No.: 813.659.9197

TEXAS BOARD OF PROFESSIONAL ENGINEERS
CERTIFICATE OF REGISTRATION # F-11852

PRODUCT: FIBERGLASS DOOR

PART OR ASSEMBLY: ELEVATIONS & HARDWARE TABLE

NO.	DATE	REVISIONS
3	10/25/21	UPDATE TO 2018 IBC/IRC
2	5/30/18	ADD FLAT FRAME LITE PROFILE
1	12/14/15	ADD H.S. GLAZING OPTION

DATE: 6/13/13
SCALE: N.T.S.
DWG. BY: JK
CHK. BY: LFS
DRAWING NO.: TX-4329
SHEET 4 OF 9

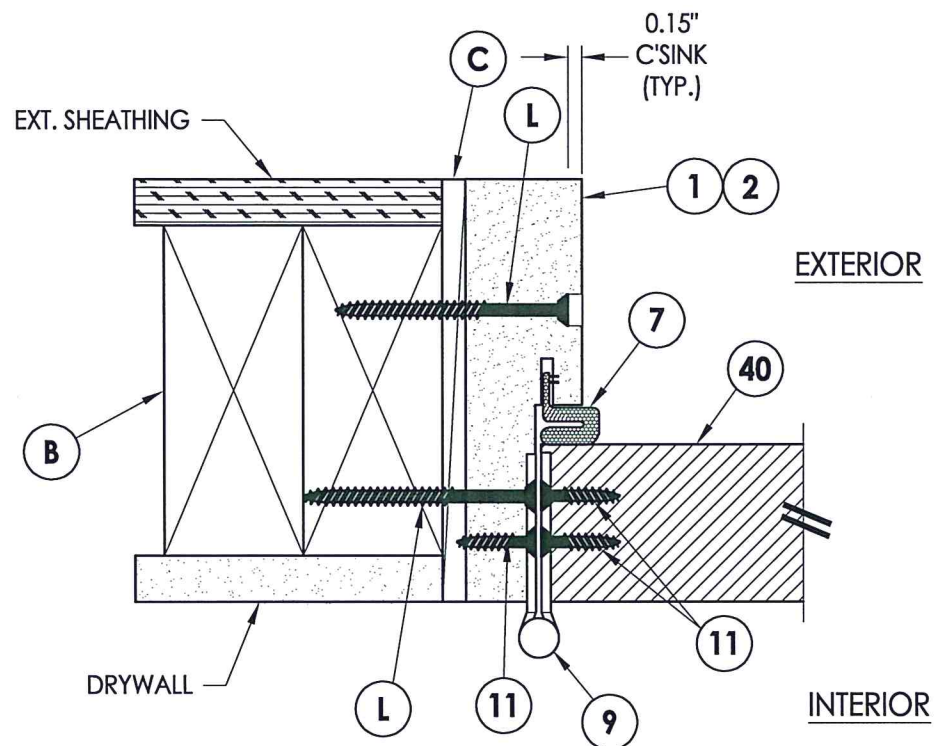

1
5 HORIZONTAL CROSS SECTION

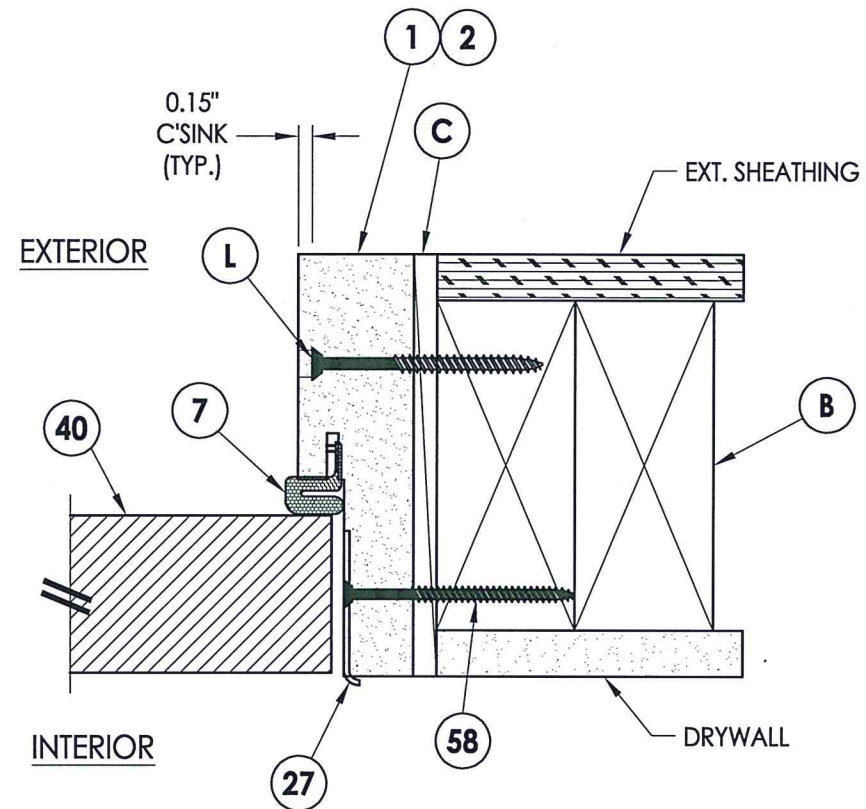

2
5 HORIZONTAL CROSS SECTION

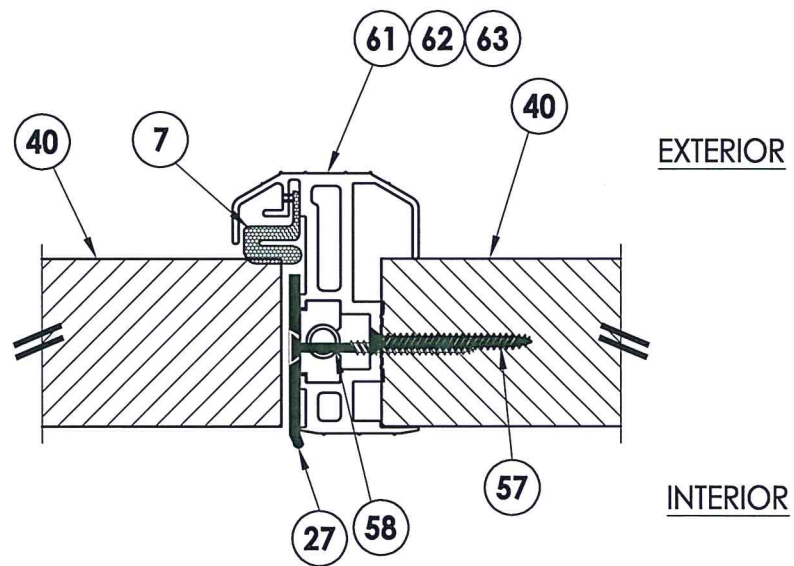

3
5 HORIZONTAL CROSS SECTION

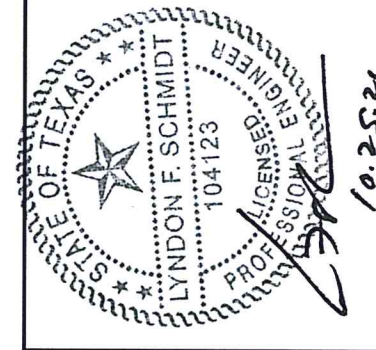

Documents Prepared By: Lyndon F. Schmidt, P.E.
TEXAS P.E. #104123

R.W. BUILDING CONSULTANTS, INC.
P.O. Box 230 Valrico FL 33595
Phone No.: 813.659.9197
TEXAS BOARD OF PROFESSIONAL ENGINEERS
CERTIFICATE OF REGISTRATION # F-11852

PRODUCT:		FIBERGLASS DOOR	
PART OR ASSEMBLY:		HORIZONTAL CROSS SECTIONS	
NO.	DATE	REVISIONS	BY
3	10/25/21	UPDATE TO 2018 IBC/IRC	LFS
2	5/30/18	ADD FLAT FRAME LITE PROFILE	LFS
1	12/14/15	ADD H.S. GLAZING OPTION	JK
			DATE
			6/13/13
			SCALE: N.T.S.
			DWG. BY: JK
			CHK. BY: LFS
			DRAWING NO.: TX-4329
			SHEET 5 OF 9

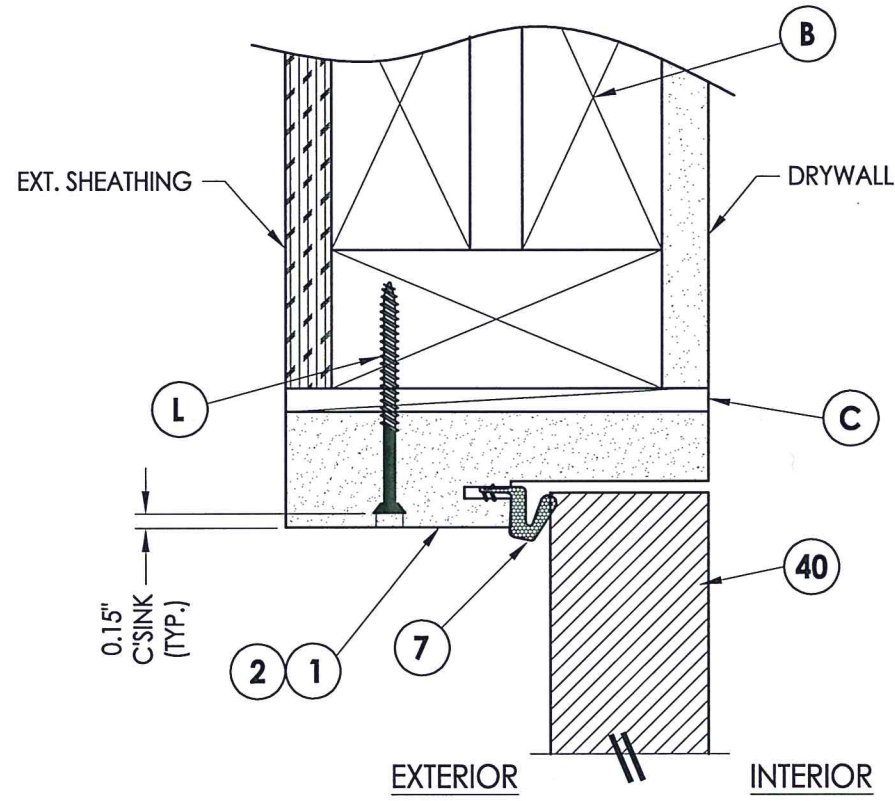

1
6 VERTICAL CROSS SECTION

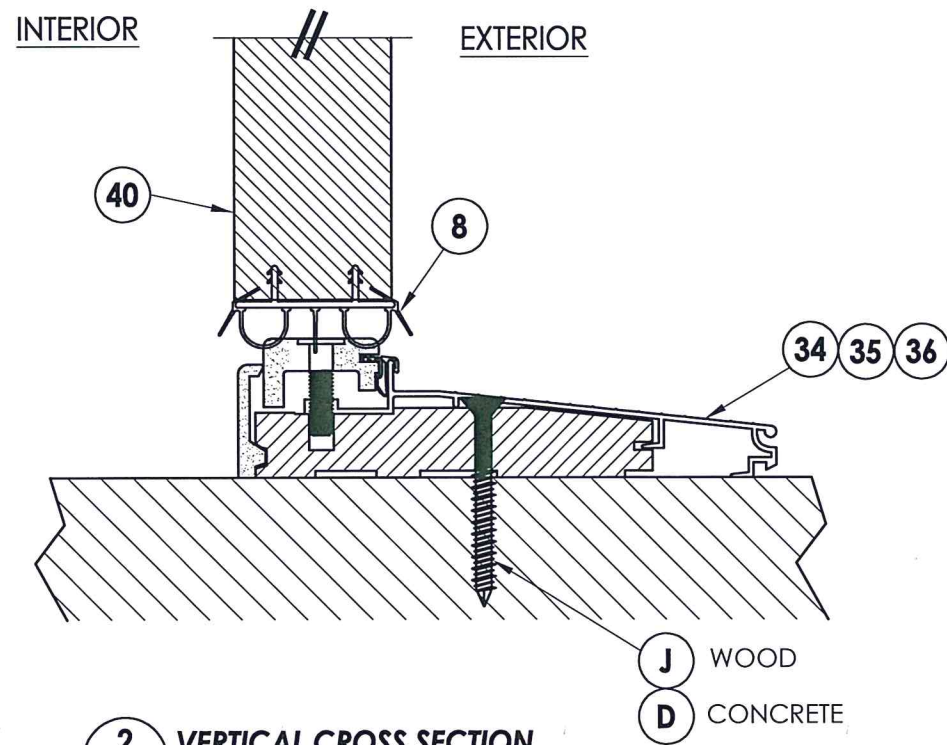

2
6 VERTICAL CROSS SECTION
Inswing configuration

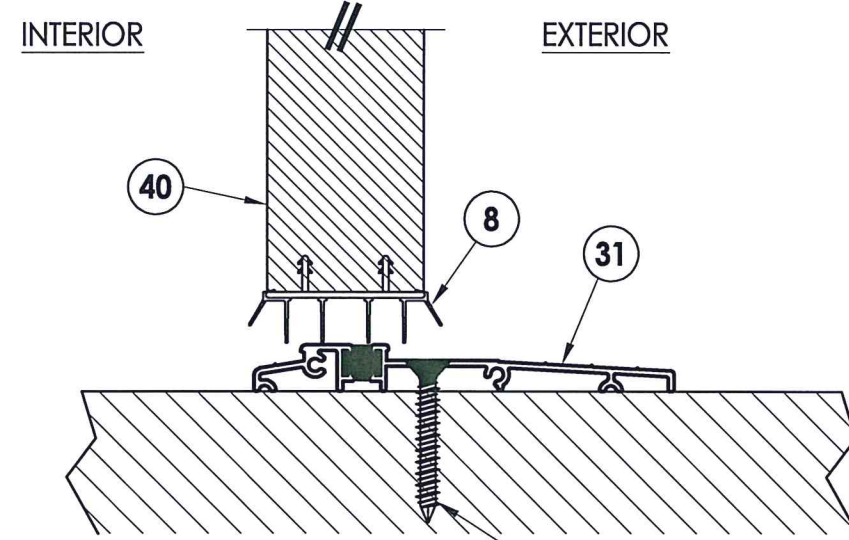

3
6 VERTICAL CROSS SECTION
Inswing configuration

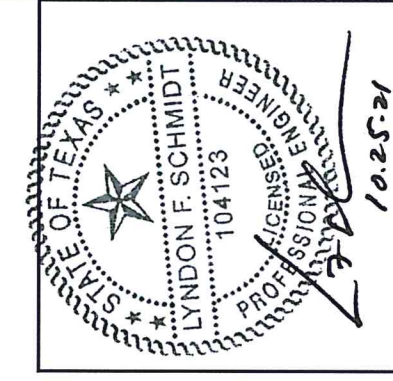

Documents Prepared By: Lyndon F. Schmidt, P.E.
TEXAS P.E. #104123

RW BUILDING CONSULTANTS, INC.
P.O. Box 230 Valrico FL 33595
Phone No.: 813.659.9197

TEXAS BOARD OF PROFESSIONAL ENGINEERS
CERTIFICATE OF REGISTRATION # F-11852

PRODUCT:	FIBERGLASS DOOR
PART OR ASSEMBLY:	VERTICAL CROSS SECTIONS

NO.	DATE	REVISIONS
3	10/25/21	UPDATE TO 2018 IBC/IRC
2	5/30/18	ADD FLAT FRAME LITE PROFILE
1	12/14/15	ADD H.S. GLAZING OPTION

DATE:	6/13/13
SCALE:	N.T.S.
DWG. BY:	JK
CHK. BY:	LFS
DRAWING NO.:	TX-4329
SHEET	6 OF 9

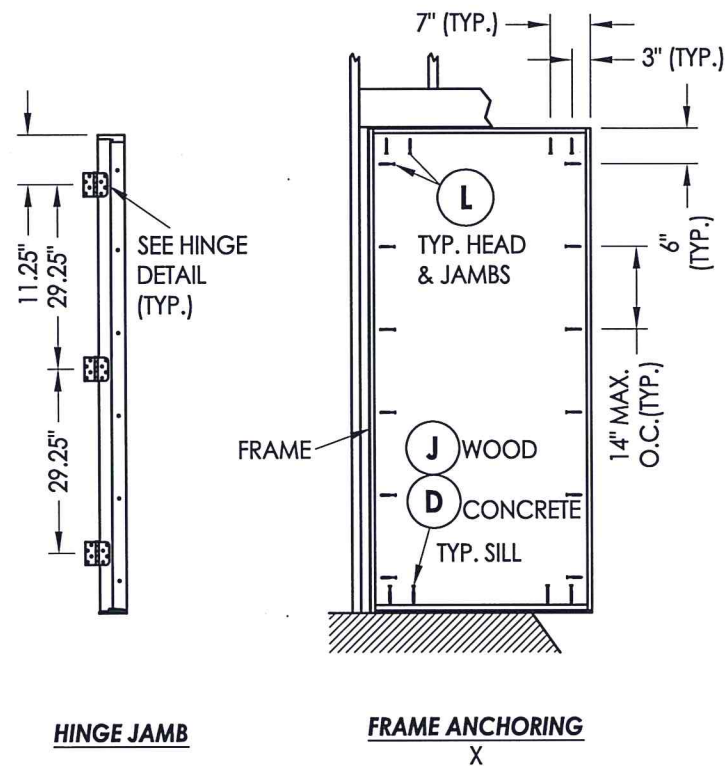

HINGE JAMB

2X FRAMING TO BE DESIGNED BY THE ENGINEER OR ARCHITECT OF RECORD BASED ON WIND LOADS AND THE CLADDING BEING USED (TYP).

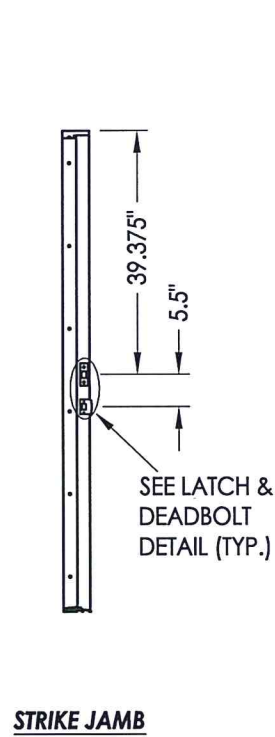

STRIKE JAMB

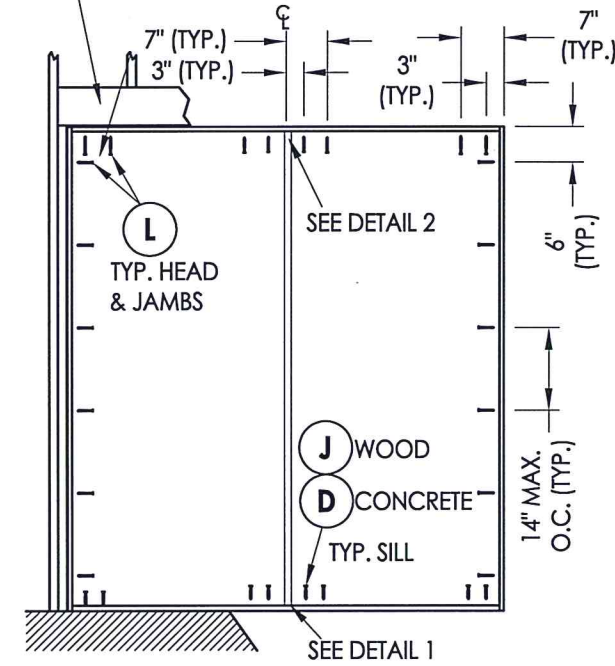

FRAME ANCHORING XX

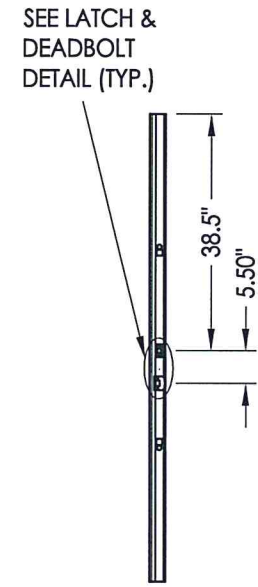

ASTRAGAL STRIKE

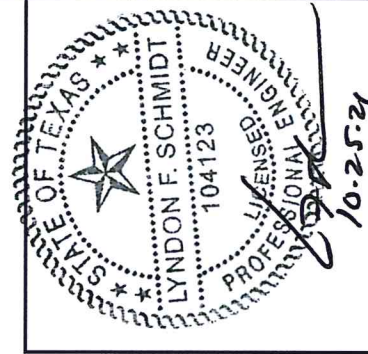

Documents Prepared By: Lyndon F. Schmidt, P.E.
TEXAS P.E. #104123

RW BUILDING CONSULTANTS, INC.

P.O. Box 230 Vairico FL 33595
Phone No.: 813.659.9197

TEXAS BOARD OF PROFESSIONAL ENGINEERS
CERTIFICATE OF REGISTRATION # F-11852

PRODUCT:	FIBERGLASS DOOR
PART OR ASSEMBLY:	FRAME ANCHORING

	LFS	10/25/21	UPDATE TO 2018 IBC/IRC	REVISIONS	
	LFS	5/30/18	ADD FLAT FRAME LITE PROFILE		
	JK	12/14/15	ADD H.S. GLAZING OPTION		
	BY	NO.	DATE		

DATE:	6/13/13
SCALE:	N.T.S.
DWG. BY:	JK
CHK. BY:	LFS
DRAWING NO.:	TX-4329
SHEET	7 OF 9

CONCRETE ANCHOR NOTES:

- Concrete anchor locations at the corners may be adjusted to maintain the min. edge distance to mortar joints.
- Concrete anchor locations noted as "MAX. ON CENTER" must be adjusted to maintain the min. edge distance to mortar joints, additional concrete anchors may be required to ensure the "MAX. ON CENTER" dimension are not exceeded.
- Concrete anchor table:

ANCHOR TYPE	ANCHOR SIZE	MIN. EMBEDMENT	MIN. CLEARANCE TO MASONRY EDGE	MIN. CLEARANCE TO ADJACENT ANCHOR
ITW TAPCON®	1/4"	1-3/4"	1-1/2"	4"
DeWALT ULTRACON+®	1/4"	1-3/4"	1"	3"

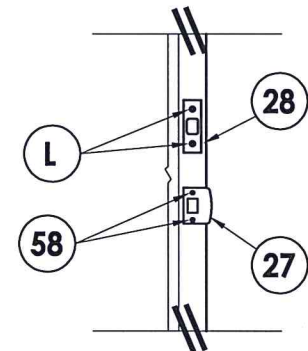
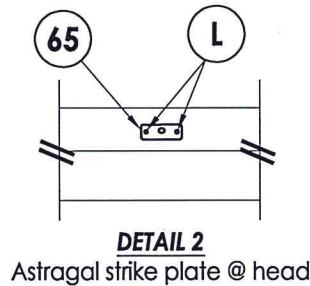
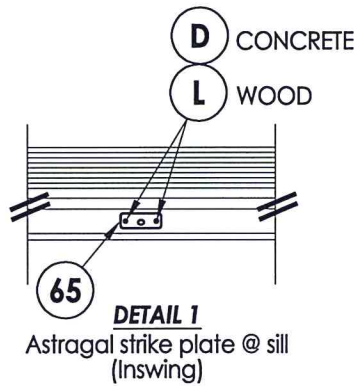

LATCH & DEADBOLT DETAIL

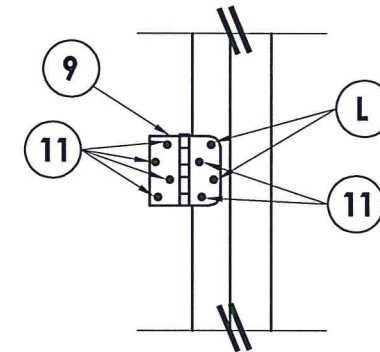

HINGE DETAIL

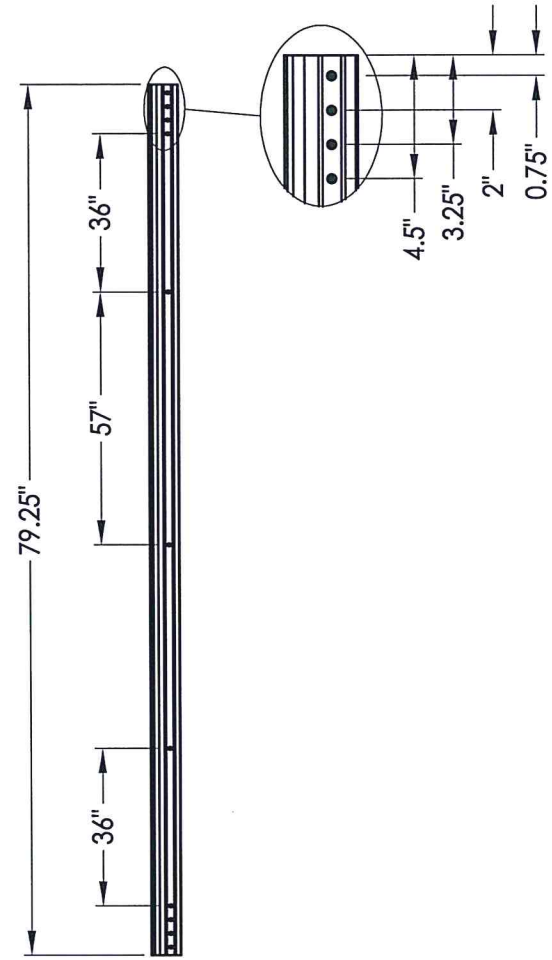

ASTRAGAL SCREW LOCATIONS

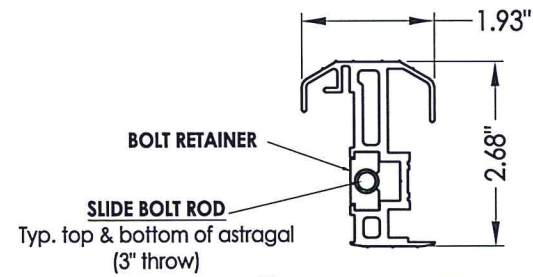

61 ALUMINUM ASTRAGAL
Therma-Tru

6'8 ALUMINUM ASTRAGAL ASSEMBLY
Therma-Tru

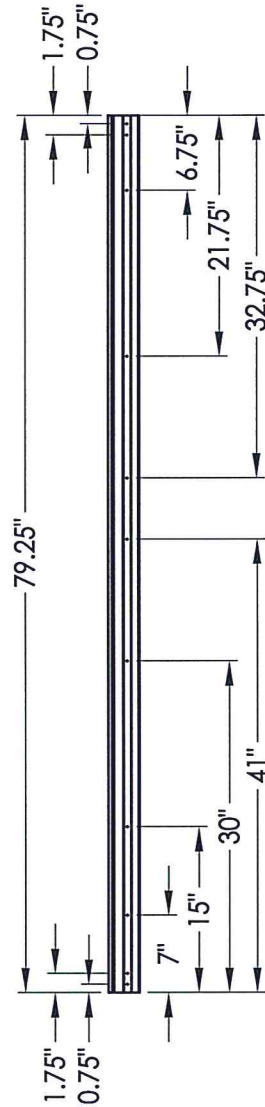

ASTRAGAL SCREW LOCATIONS

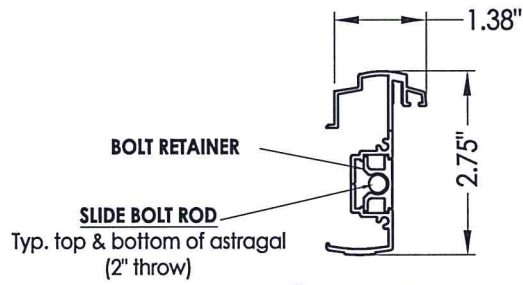

62 ASTRAGAL
Columbia

6'8 ALUMINUM ASTRAGAL ASSEMBLY
Columbia

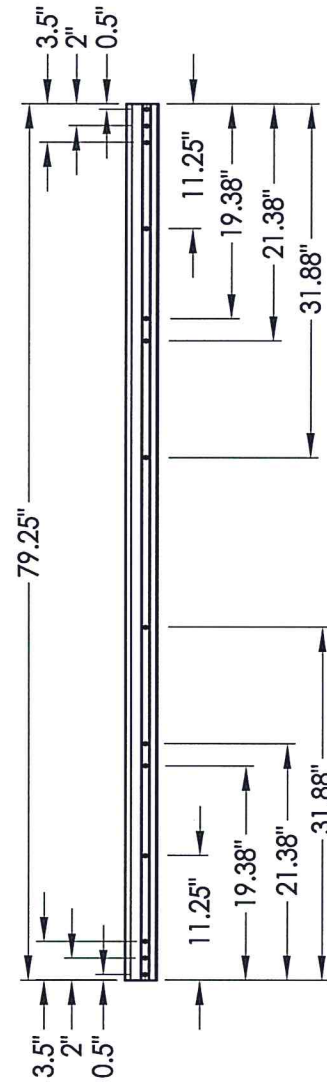

ASTRAGAL SCREW LOCATIONS

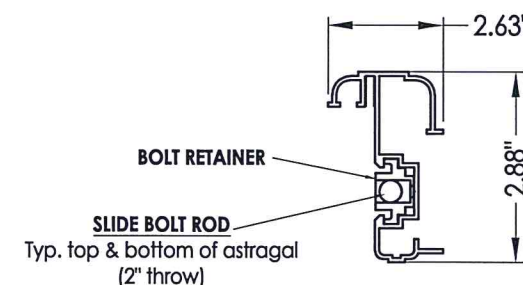

63 ASTRAGAL
DLP

6'8 ALUMINUM ASTRAGAL ASSEMBLY
DLP



Documents Prepared By: Lyndon F. Schmidt, P.E.
TEXAS P.E. #104123

RW BUILDING CONSULTANTS, INC.
P.O. Box 230 Valrico FL 33595
Phone No.: 813.659.9197
TEXAS BOARD OF PROFESSIONAL ENGINEERS
CERTIFICATE OF REGISTRATION # F-11852

PRODUCT:		FIBERGLASS DOOR	
PART OR ASSEMBLY:		ASTRAGAL DETAILS	
NO.	DATE	BY	REVISIONS
3	10/25/21	LFS	UPDATE TO 2018 IBC/IRC
2	5/30/18	LFS	ADD FLAT FRAME LITE PROFILE
1	12/14/15	JK	ADD H.S. GLAZING OPTION
DATE:		6/13/13	
SCALE:		N.T.S.	
DWG. BY:		JK	
CHK. BY:		LFS	
DRAWING NO.:		TX-4329	
SHEET		8 OF 9	

BILL OF MATERIALS		
ITEM #	DESCRIPTION	MATERIAL
B	2X FRAMING (G >= 0.42)	WOOD
C	1/4" MAX. SHIM SPACE	-
D	1/4" PFH DeWALT OR ITW CONCRETE SCREW (1-3/4" MIN. EMB.)	STEEL
J	#10 X 3" PFH WOOD SCREW (1-1/2" MIN. EMB.)	STEEL
L	#10 X 2-1/2" PFH WOOD SCREW (1.15" MIN. EMB.)	STEEL
1	HEAD & JAMB	COMP
2	HEAD & JAMB	WOOD
7	WEATHERSTRIP (THERMA-TRU)	FOAM
8	DOOR BOTTOM SWEEP	VINYL
9	4" x 4" HINGE	STEEL
11	#9 X 3/4" PFH WOOD SCREW	STEEL
27	LATCH STRIKE PLATE	STEEL
28	DEADBOLT STRIKE PLATE	STEEL
31	ADA THRESHOLD	ALUM
34	INSWING THRESHOLD	ALUM/COMP
35	INSWING THRESHOLD	ALUM/COMP
36	INSWING THRESHOLD	ALUM/COMP
40	DOOR PANEL - SEE DOOR PANEL DETAIL SHEET FOR DETAILS	-
57	#8 X 2" PFH SMS	STEEL
58	#8 X 2-1/2" PFH WOOD SCREW	STEEL
61	ASTRAGAL (THERMA-TRU)	ALUM
62	ASTRAGAL (COLUMBIA)	ALUM
63	ASTRAGAL (DLP)	ALUM
65	ASTRAGAL STRIKE PLATE	STEEL

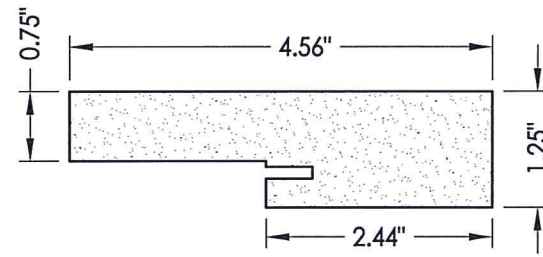

1 HEAD & JAMB
Composite

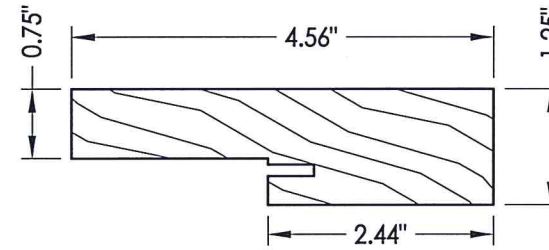

2 HEAD & JAMB
Finger joint pine

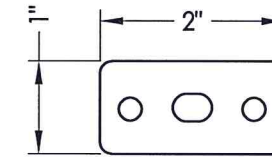

65 HEAD & SILL STRIKE PLATE

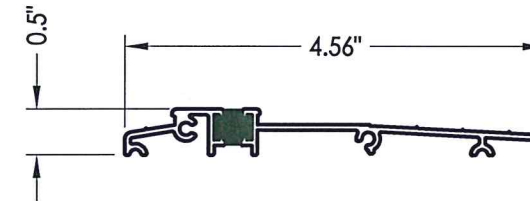

31 ADA THRESHOLD
Columbia

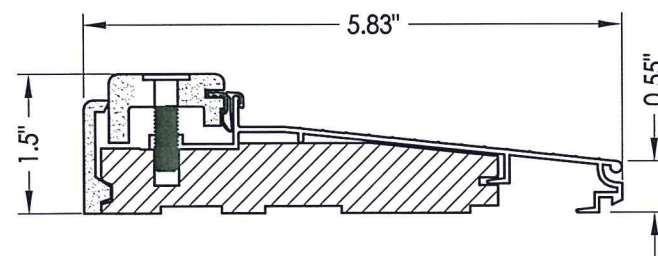

34 INSWING THRESHOLD
Therma-Tru

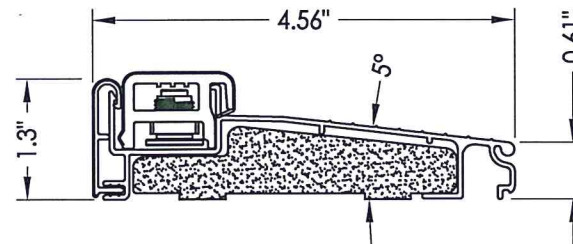

35 INSWING THRESHOLD
Endura ZAIL 4565
with Composite Substrate

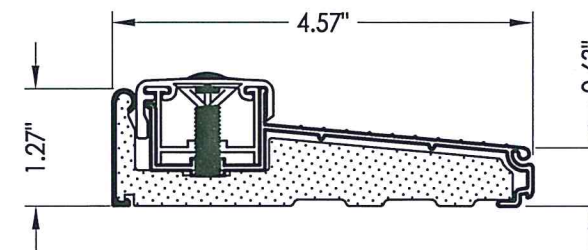

36 INSWING THRESHOLD
Columbia 900 Series

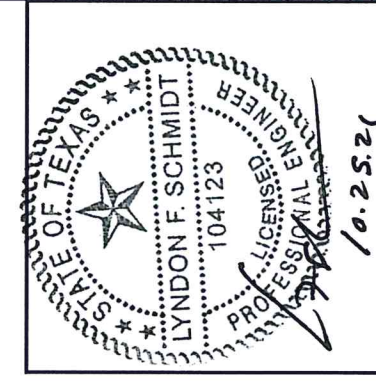

Documents Prepared By: Lyndon F. Schmidt, P.E.
TEXAS P.E. #104123

R.W. BUILDING CONSULTANTS, INC.
P.O. Box 230 Valrico FL, 33595
Phone No.: 813.659.9197

TEXAS BOARD OF PROFESSIONAL ENGINEERS
CERTIFICATE OF REGISTRATION # F-11852

PRODUCT: FIBERGLASS DOOR
PART OR ASSEMBLY: BILL OF MATERIALS & COMPONENTS

NO.	DATE	REVISIONS
3	10/25/21	UPDATE TO 2018 IBC/IRC
2	5/30/18	ADD FLAT FRAME LITE PROFILE
1	12/14/15	ADD H.S. GLAZING OPTION
		JK
		BY

DATE: 6/13/13
SCALE: N.T.S.
DWG. BY: JK
CHK. BY: LFS
DRAWING NO.: TX-4329
SHEET 9 OF 9