



Distributed by: ProBuild Company, LLC
302 North Mile 2-1/2 East
Mercedes, TX 78570

FIBERGLASS ENTRY DOOR INSWING / OUTSWING "IMPACT"

EVALUATED FOR USE IN THE STATE OF TEXAS

The Fiberglass Glazed Door described herein complies with the 2006 International Residential Code (IRC), Sections R301 & R613 and the 2006 International Building Code (IBC), Sections 1405.12, 1609, 1714.5, 2403 and 2404 (including Texas revisions) subject to the following conditions:

1. Anchors shall be as listed and spaced as shown in the details. Anchor embedment to base material shall be beyond wall dressing or stucco.
2. This system has been tested and evaluated as a large missile impact protective system for installation in the Seaward, Inland I and Inland II areas. This product meets missile level "D" as defined in ASTM E 1996.
3. Allowable design pressure requirements must be equal to or less than the design pressure rating shown in the design pressure chart, sheet 1 of this drawing.
4. Conditions not covered by this drawing are subject to further engineering analysis.

TABLE OF CONTENTS	
SHEET #	DESCRIPTION
1	Typical elevations, design pressures & general notes
2	Door/Sidelite panel details
3	Lite frame and glazing details
4	Elevations
5	Horizontal cross sections
6	Vertical cross sections
7	Vertical cross sections
8	Frame anchoring
9	Bill of materials & components

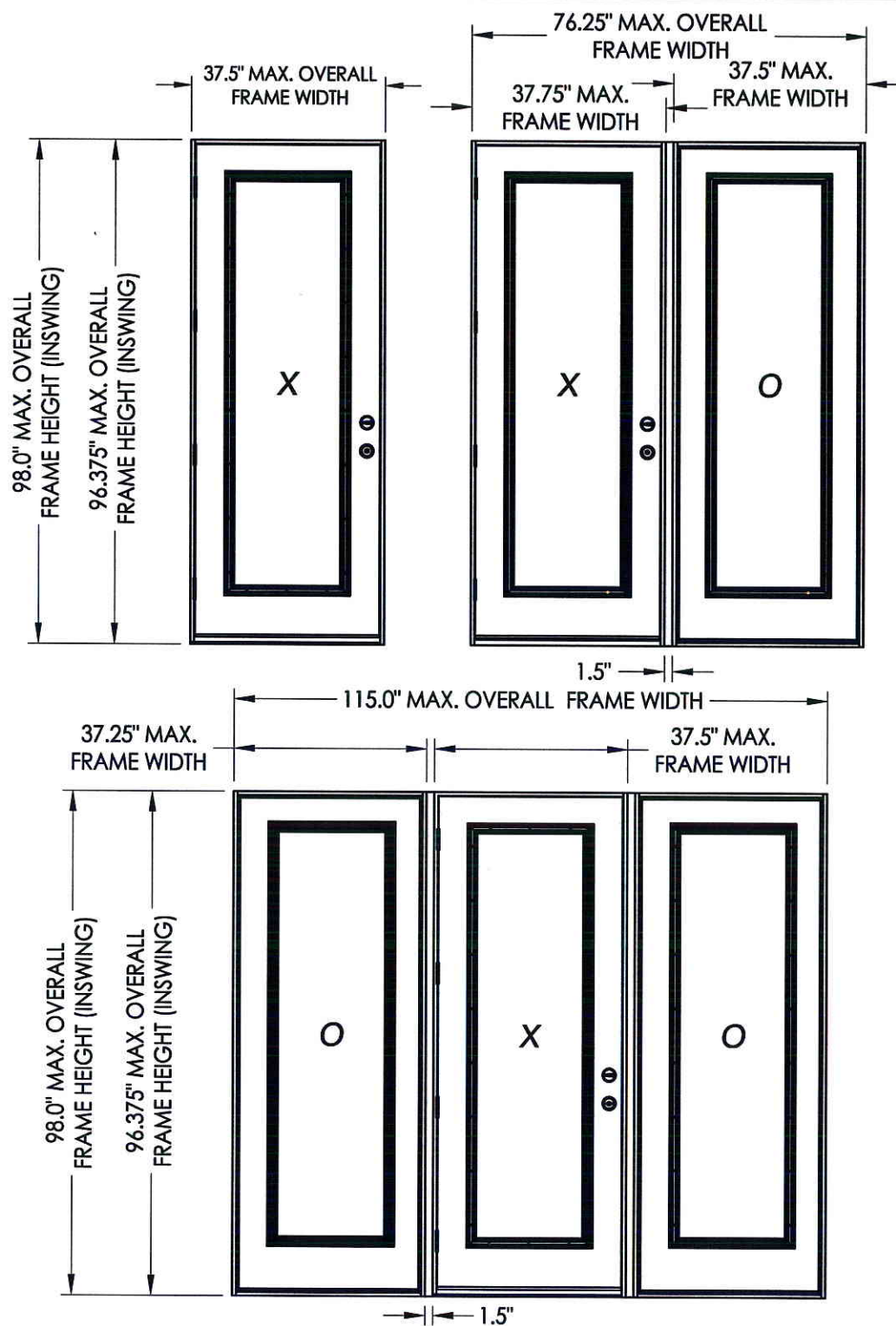

CONFIGURATION	MAX. FRAME DIMENSION	DESIGN PRESSURE (PSF) INSWING		DESIGN PRESSURE (PSF) OUTSWING	
		POSITIVE	NEGATIVE	POSITIVE	NEGATIVE
X	37.5" x 98.0"	+35.0	-40.0	+35.0	-35.0
XO/OX	76.25" x 98.0"	+35.0	-40.0	+35.0	-35.0
OXO	115.0" x 98.0"	+35.0	-40.0	+35.0	-35.0

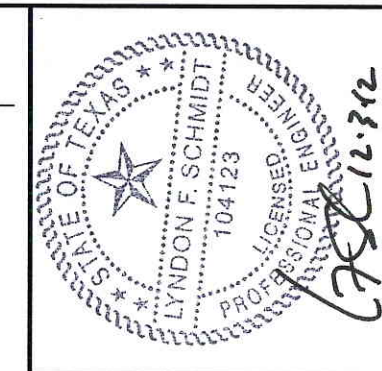

Documents Prepared By: Lyndon F. Schmidt, P.E.
 TEXAS P.E. #104123

RW BUILDING CONSULTANTS, INC.
 P.O. Box 230 Vairico FL 33595
 Phone No.: 813.659.9197

TEXAS BOARD OF PROFESSIONAL ENGINEERS
 CERTIFICATE OF REGISTRATION # F-11852

PRODUCT: FIBERGLASS DOOR

PART OR ASSEMBLY: TYPICAL ELEVATION, DESIGN PRESSURES & GENERAL NOTES

NO.	DATE	BY	REVISIONS

DATE: 11/8/12

SCALE: N.T.S.

DWG. BY: JK

CHK. BY: LFS

DRAWING NO.: TX-4278

SHEET 1 OF 9

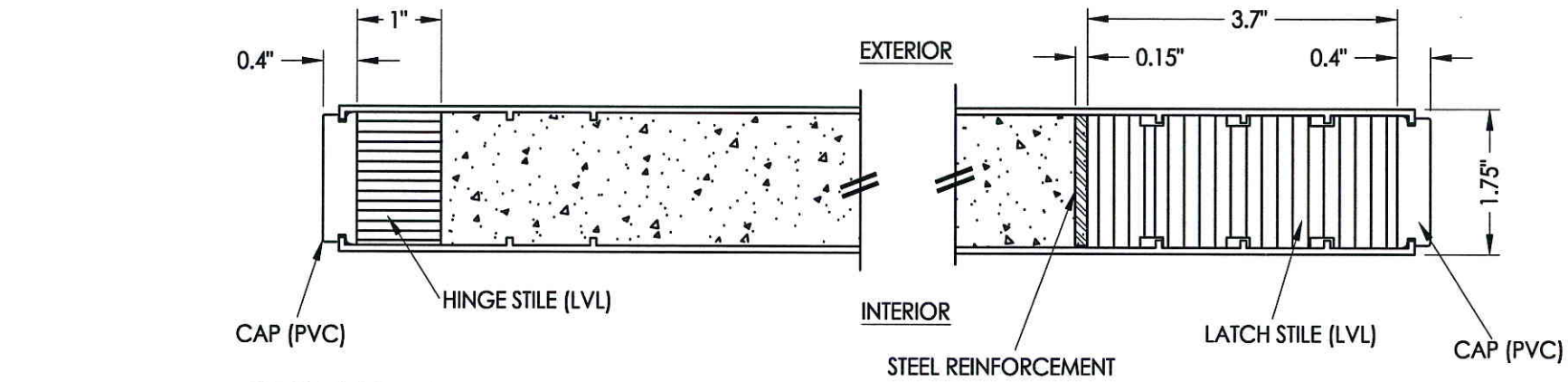

1
2 **HORIZONTAL CROSS SECTION**

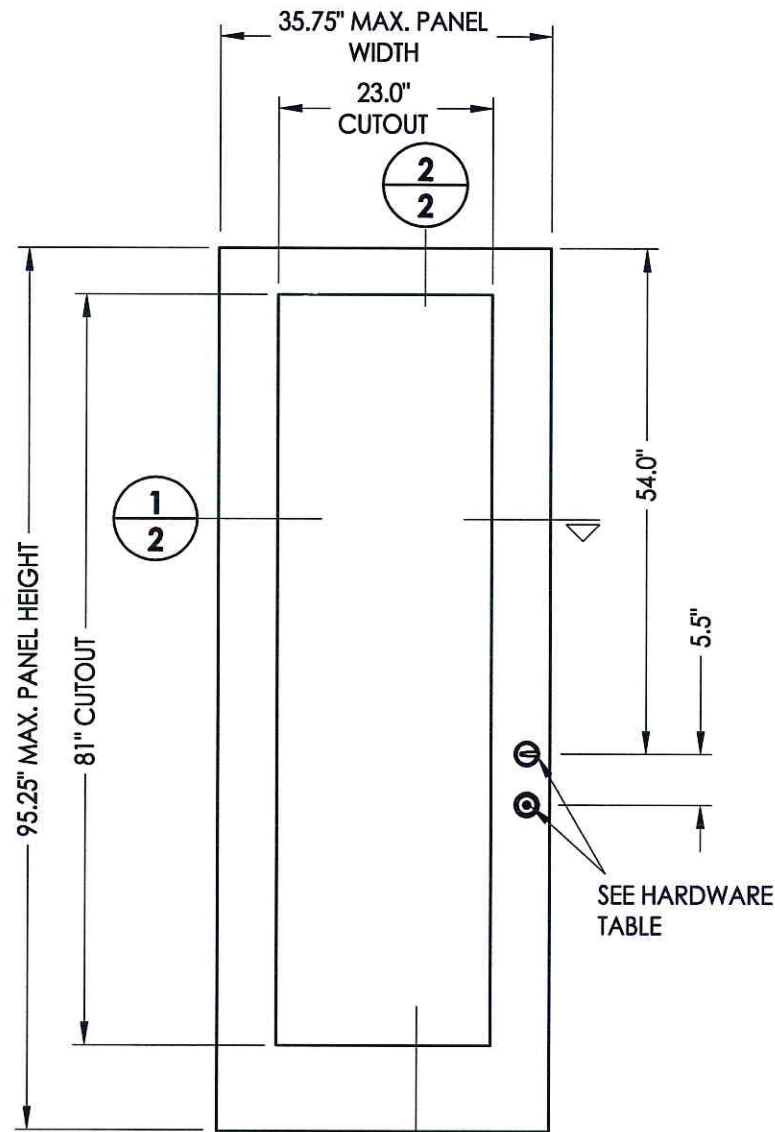

40 **DOOR PANEL**
Fiberglass (Plastpro)

50 **SIDELITE PANEL**
Fiberglass (Plastpro)

HARDWARE TABLE		
MANUFACTURER	MODEL	
KWIKSET	Knob:	SIGNATURE SERIES
	DEADBOLT:	SIGNATURE SERIES (980)

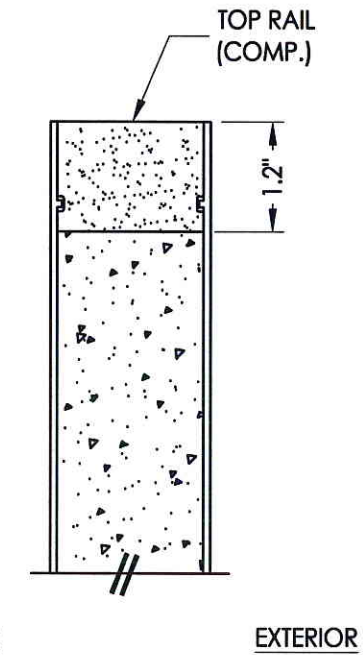

2
2 **VERTICAL CROSS SECTION**

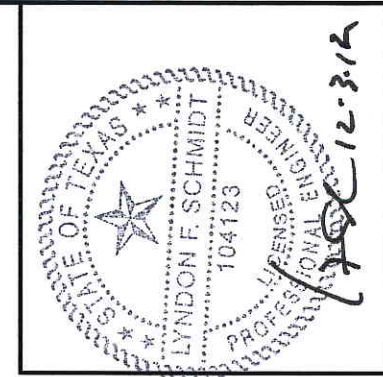

Documents Prepared By: Lyndon F. Schmidt, P.E.
TEXAS P.E. #104123

RW BUILDING CONSULTANTS, INC.
P.O. Box 230 Valrico FL, 33595
Phone No.: 813.659.9197

TEXAS BOARD OF PROFESSIONAL ENGINEERS
CERTIFICATE OF REGISTRATION # F-11852

PRODUCT:	FIBERGLASS DOOR
PART OR ASSEMBLY:	DOOR/SIDELITE PANEL DETAILS

NO.	DATE	BY	REVISIONS

DATE: 11/8/12
SCALE: N.T.S.
DWG. BY: JK
CHK. BY: LFS
DRAWING NO.: TX-4278
SHEET 2 OF 9

R:\A - Projects\Project Folders\Proj 1601 - 1700\PF 1676\D. RWBC Drawings\TX-4278-79.dwg, 3.1

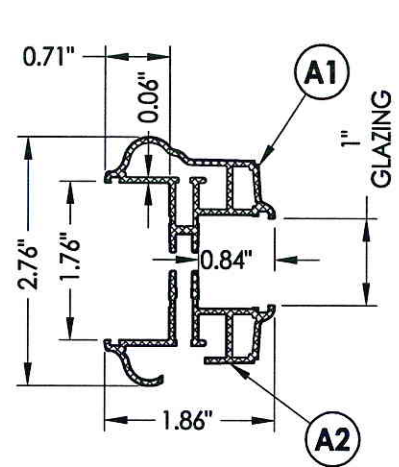

ODL LITE FRAME CROSS SECTION
1" GLAZING

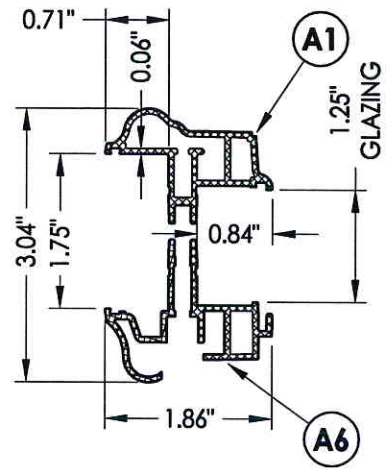

ODL LITE FRAME CROSS SECTION
1.25" GLAZING

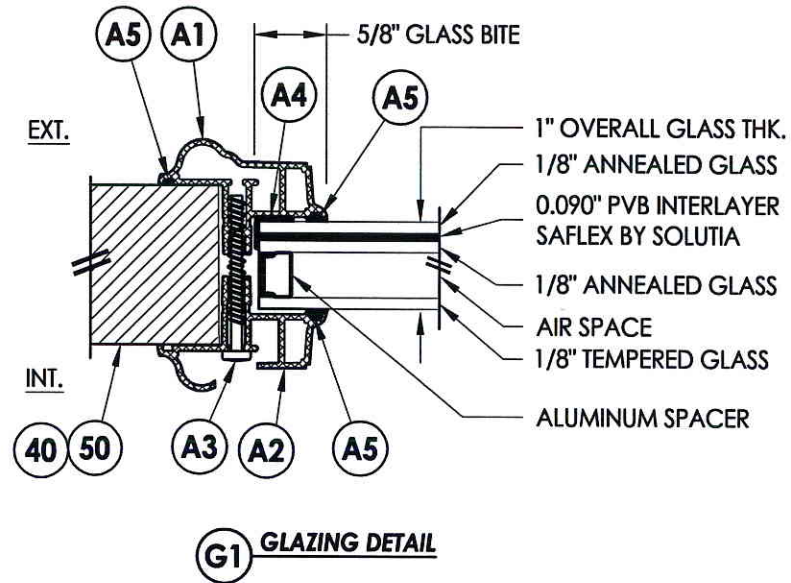

G1 GLAZING DETAIL

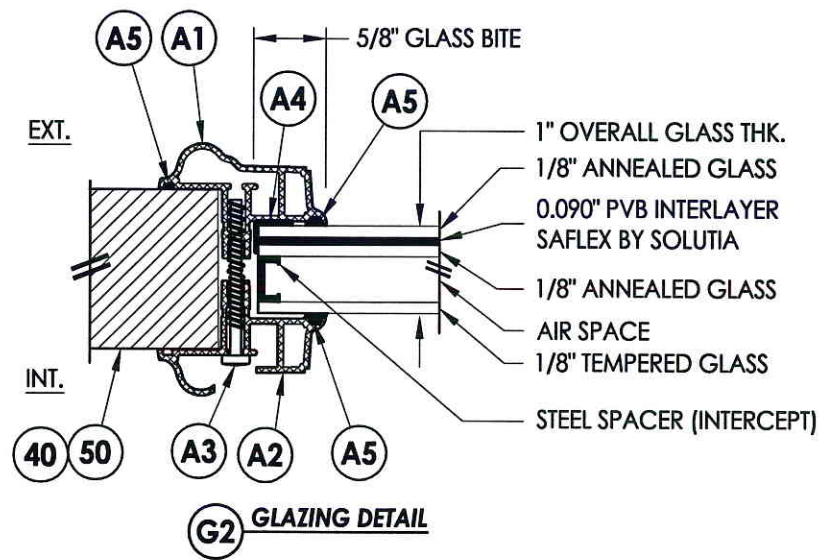

G2 GLAZING DETAIL

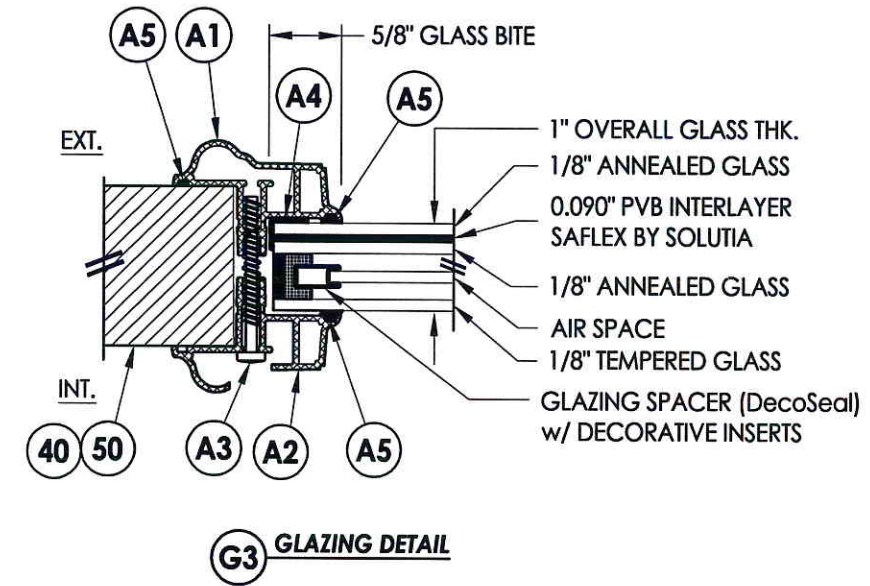

G3 GLAZING DETAIL

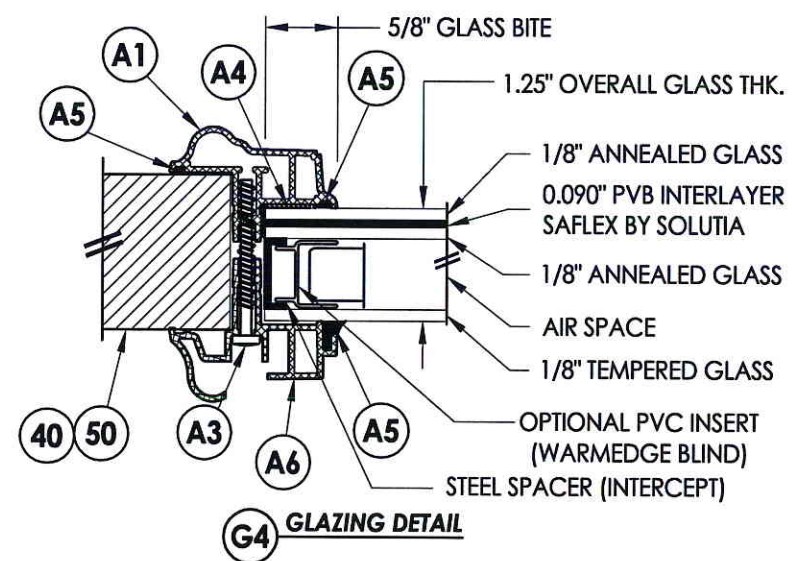

G4 GLAZING DETAIL

MAX. DESIGN PRESSURE FOR G4 GLAZING
INSWING = +30/-30 PSF
OUTSWING = +30/-30 PSF

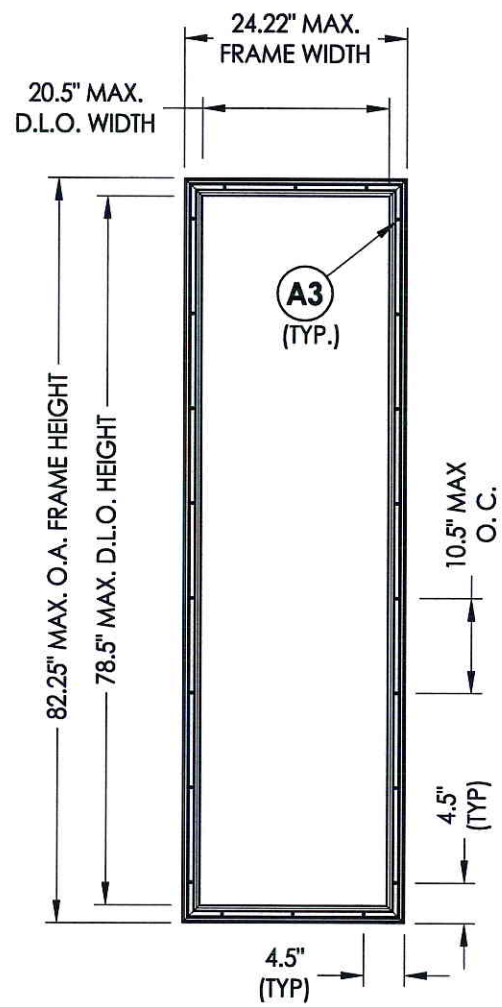

ODL LITE FRAME

ITEM #	DESCRIPTION	MATERIAL
A1	EXTERIOR FRAME	ALUM.
A2	INTERIOR FRAME (1" GLAZING)	ALUM.
A3	#7-19 X 1-3/4" PPH SELF-DRILLING SMS	STEEL
A4	DOW 995 STRUCTURAL SILICONE	SILICONE
A5	NON STRUCTURAL BACKBEDDING SEALANT (READISEAL)	-
A6	INTERIOR FRAME (1" GLAZING)	ALUM.

MAX. DESIGN PRESSURE FOR G4 GLAZING
INSWING = +30/-30 PSF
OUTSWING = +30/-30 PSF

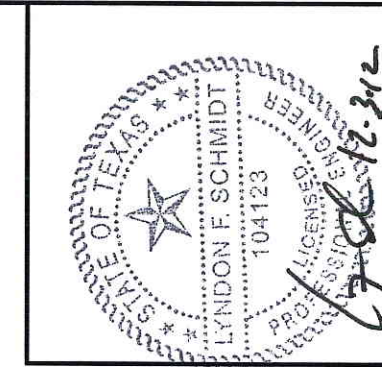

Documents Prepared By: Lyndon F. Schmidt, P.E.
TEXAS P.E. #104123

RW BUILDING CONSULTANTS, INC.
P.O. Box 230 Valrico FL 33595
Phone No.: 813.659.9197

TEXAS BOARD OF PROFESSIONAL ENGINEERS
CERTIFICATE OF REGISTRATION # F-11852

PRODUCT:	FIBERGLASS DOOR	
	LITE FRAME & GLAZING DETAILS	
PART OR ASSEMBLY:	BY	DATE
	NO.	DATE
REVISIONS		
DATE:	11/8/12	
SCALE:	N.T.S.	
DWG. BY:	JK	
CHK. BY:	LFS	
DRAWING NO.:	TX-4278	
SHEET	3	OF 9

© 2012 R.W. BUILDING CONSULTANTS INC.

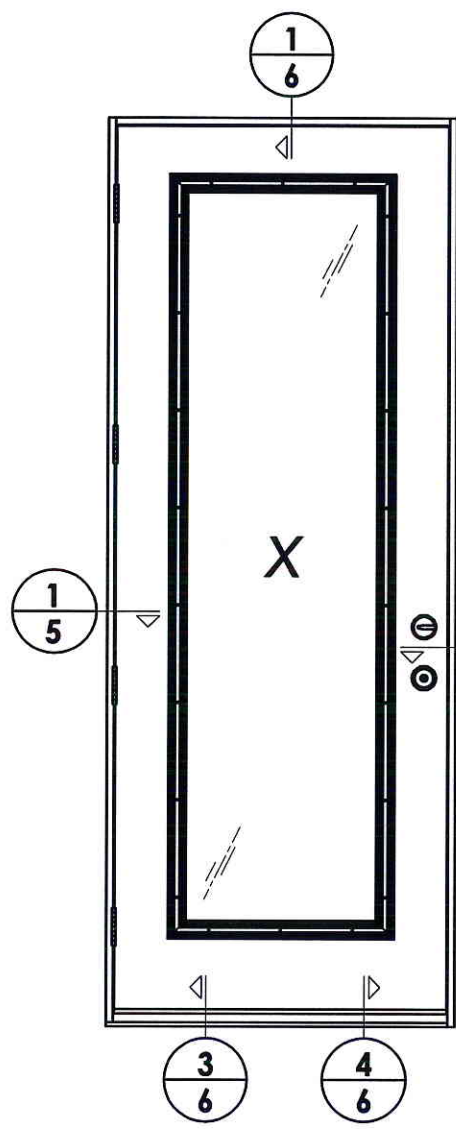

ELEVATION
X

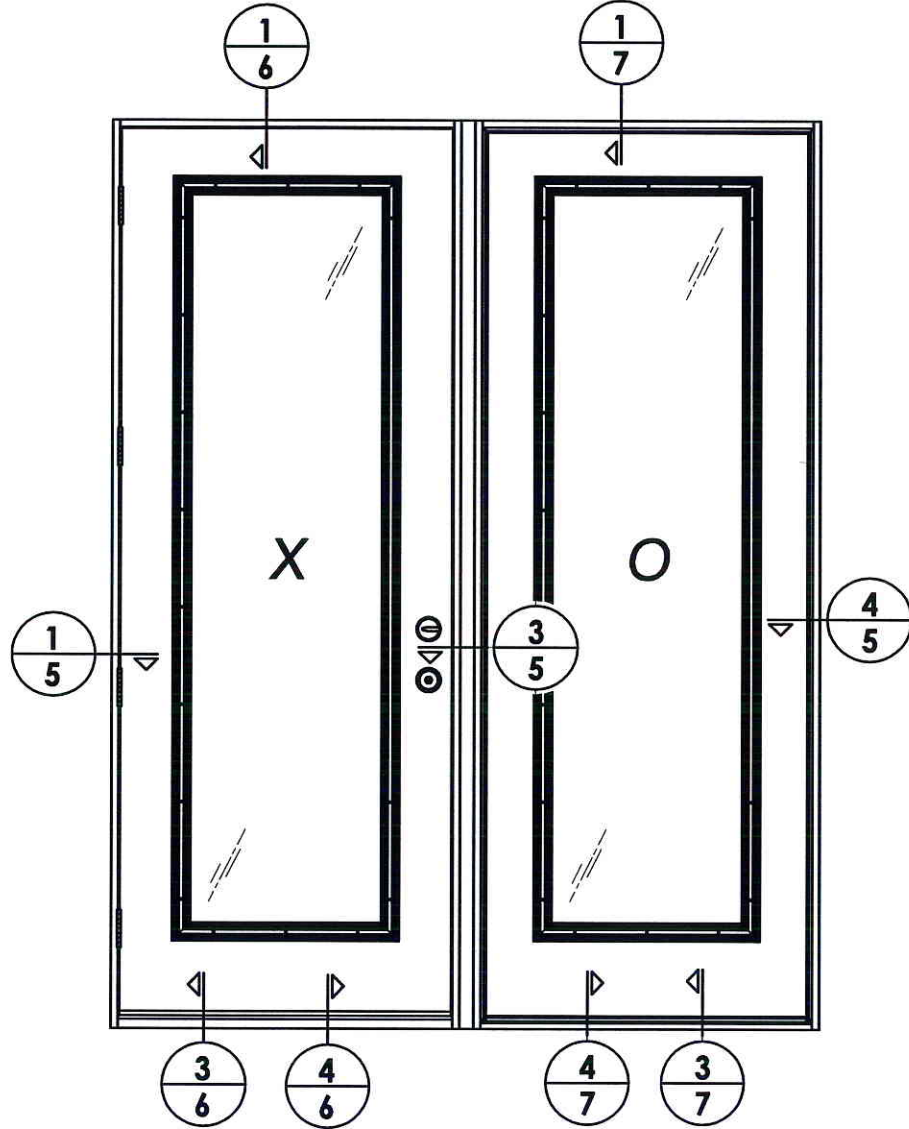

ELEVATION
XO / OX

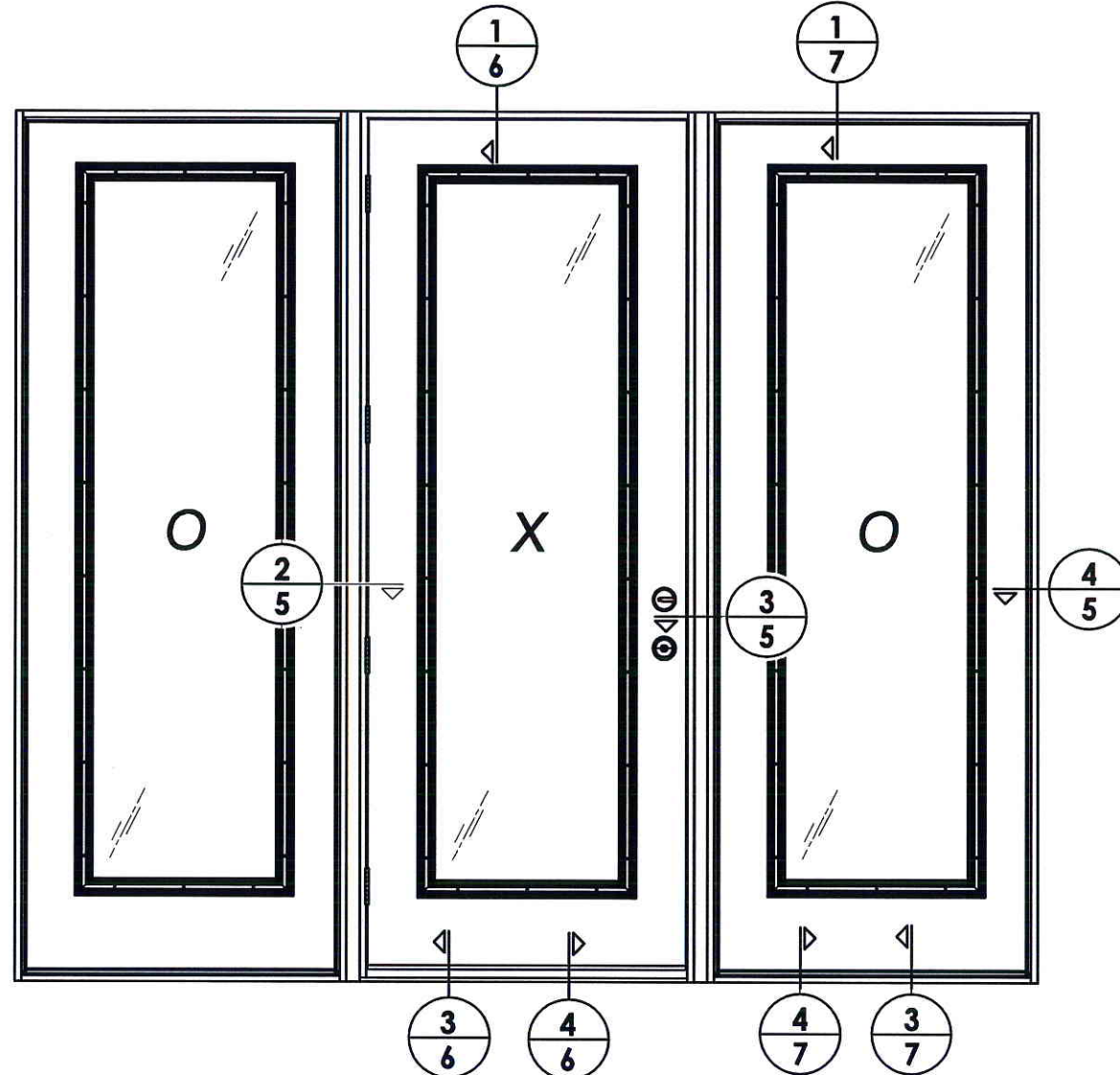

ELEVATION
OXO

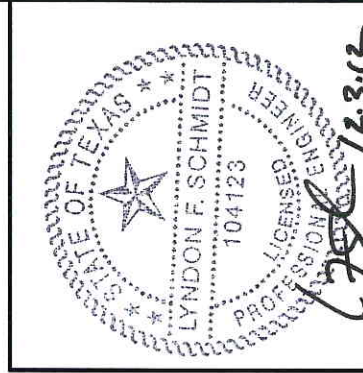

Documents Prepared By: Lyndon F. Schmidt, P.E.
TEXAS P.E. #104123

RW BUILDING CONSULTANTS, INC.
P.O. Box 230 Valrico FL, 33595
Phone No.: 813.659.9197

TEXAS BOARD OF PROFESSIONAL ENGINEERS
CERTIFICATE OF REGISTRATION # F-11852

PRODUCT: FIBERGLASS DOOR	
PART OR ASSEMBLY: ELEVATIONS	
NO.	DATE
BY	REVISIONS
DATE: 11/8/12	
SCALE: N.T.S.	
DWG. BY: JK	
CHK. BY: LFS	
DRAWING NO.: TX-4278	
SHEET 4 OF 9	

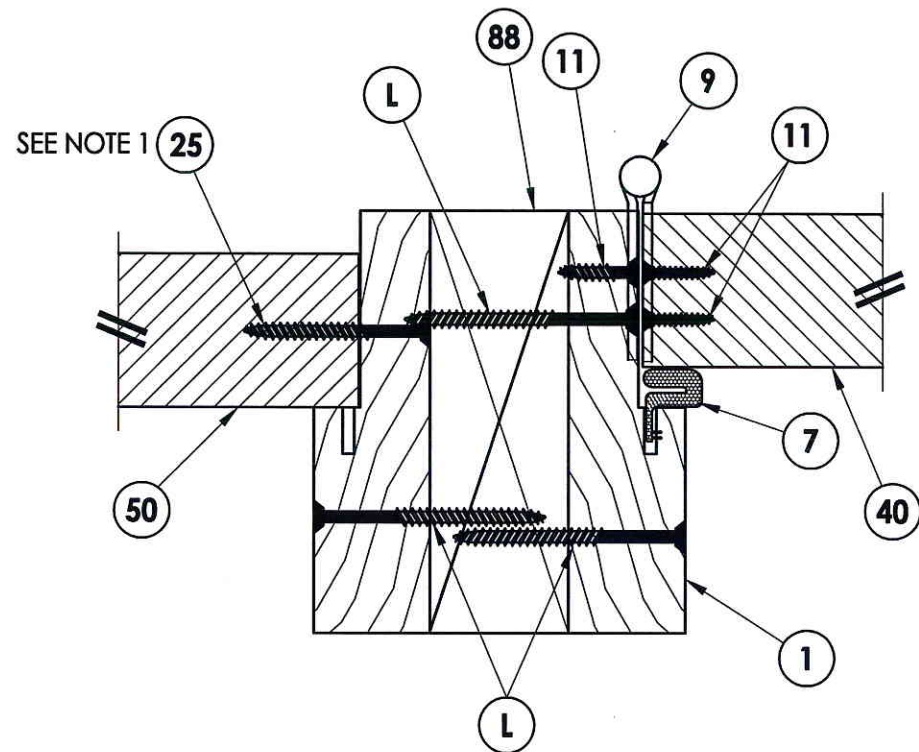

2 HORIZONTAL CROSS SECTION
5 Outswing shown - Inswing also approved

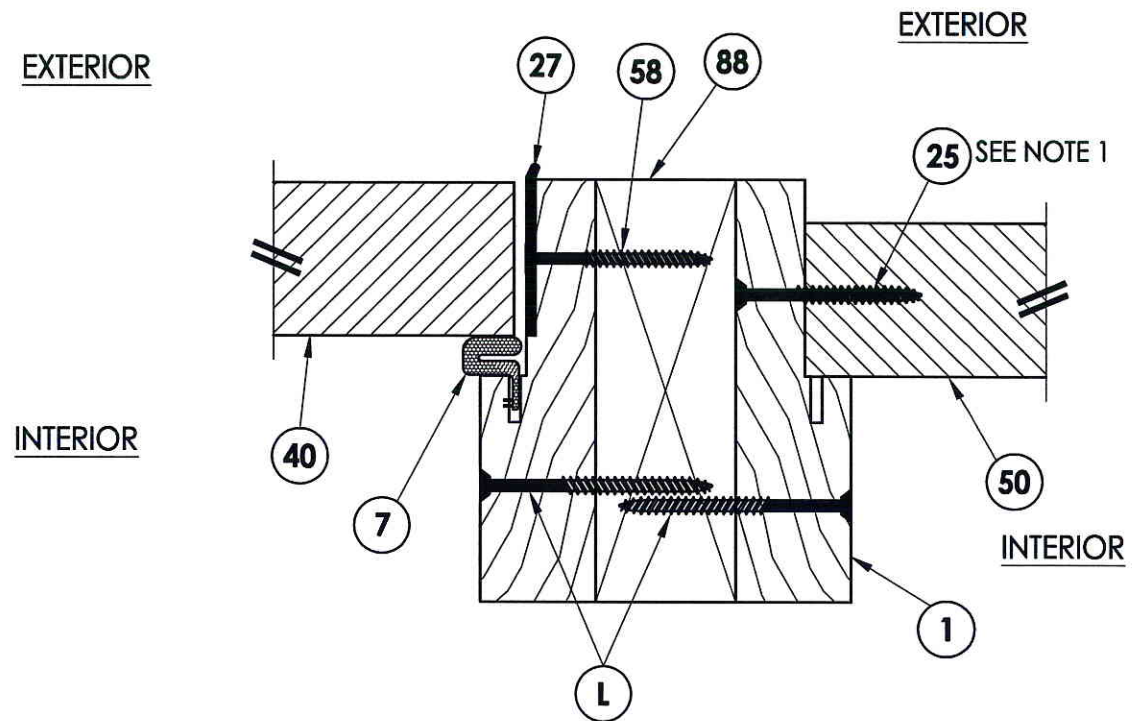

3 HORIZONTAL CROSS SECTION
5 Outswing shown - Inswing also approved

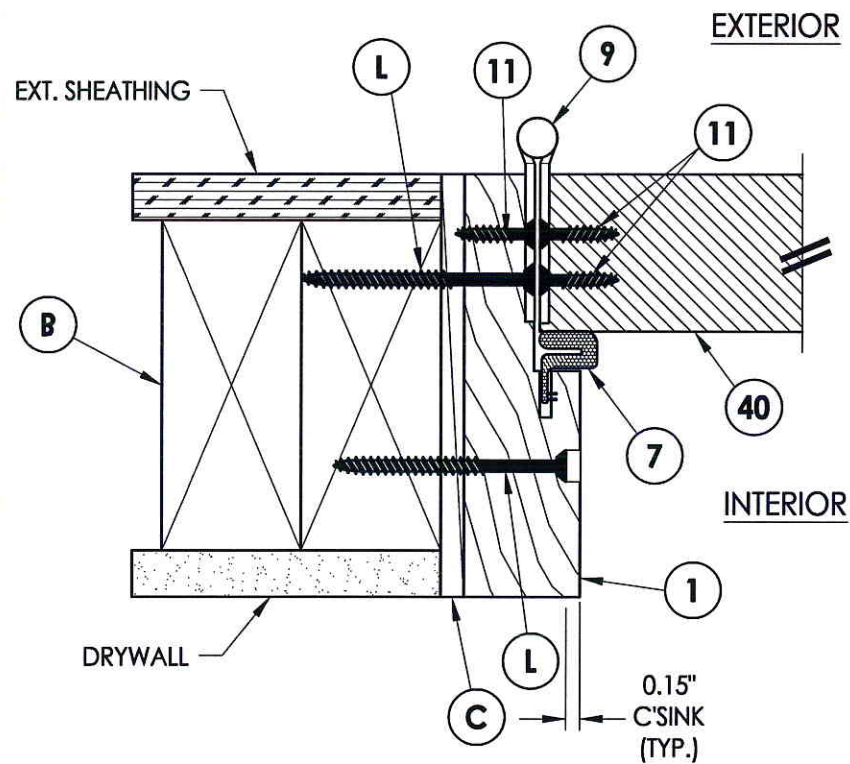

1 HORIZONTAL CROSS SECTION
5 Outswing shown - Inswing also approved

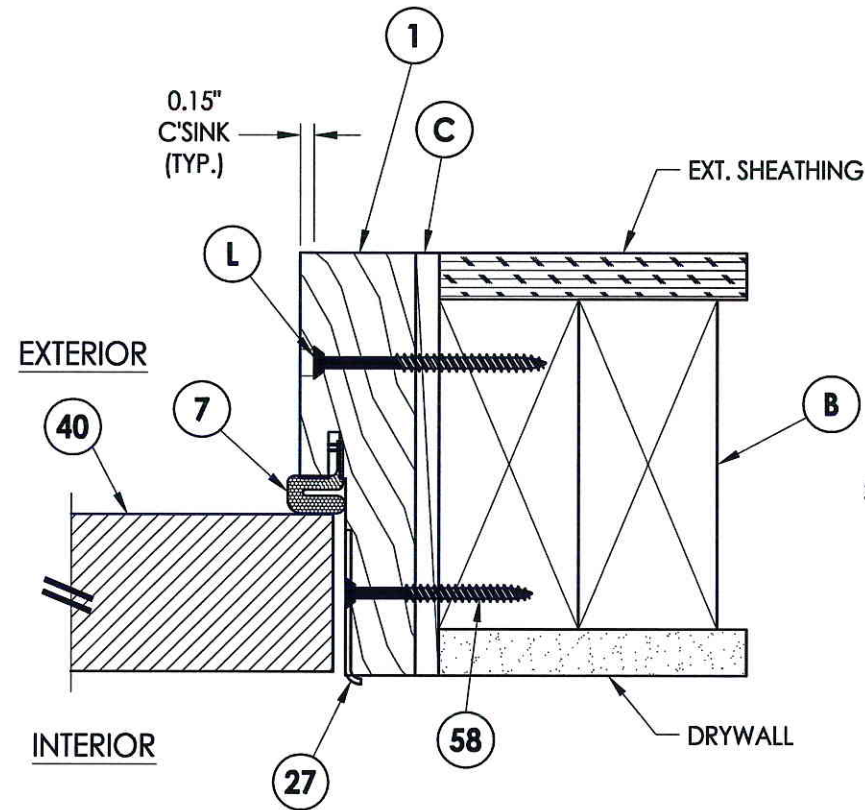

5 HORIZONTAL CROSS SECTION
5 Inswing shown - inswing also approved

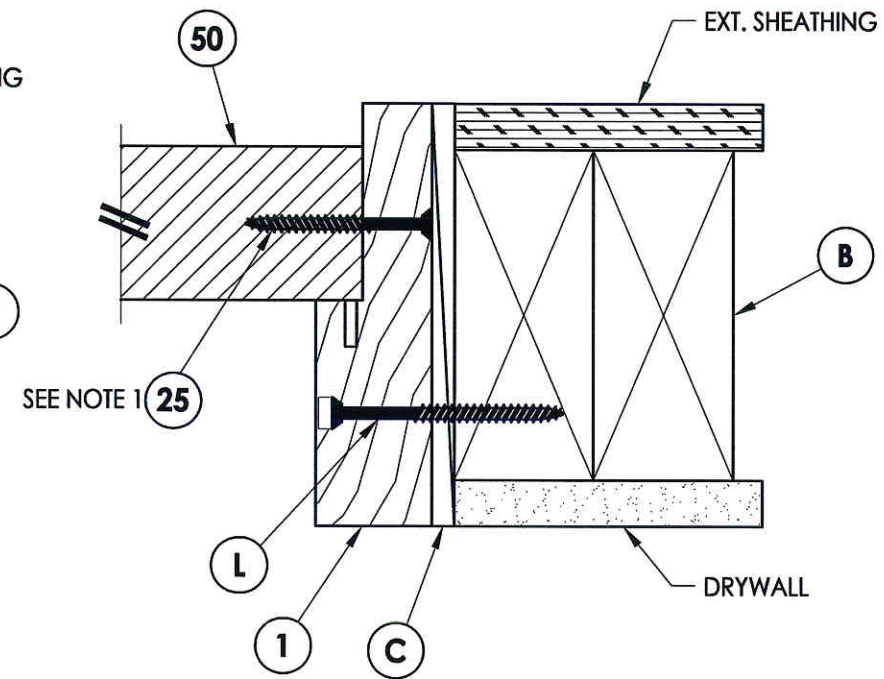

4 HORIZONTAL CROSS SECTION
5 Outswing shown - Inswing also approved

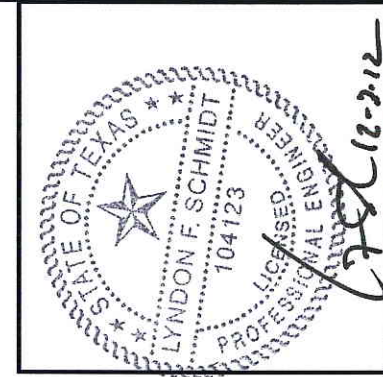

NOTE:
 1. Sidelite panel screws located 6" from each end plus 5 more equally spaced (7 screws total).

Documents Prepared By: Lyndon F. Schmidt, P.E.
 TEXAS P.E. #104123

RW BUILDING CONSULTANTS, INC.
 P.O. Box 230 Valrico FL 33595
 Phone No.: 813.659.9197

TEXAS BOARD OF PROFESSIONAL ENGINEERS
 CERTIFICATE OF REGISTRATION # F-11852

PRODUCT: FIBERGLASS DOOR	
PART OR ASSEMBLY: HORIZONTAL CROSS SECTIONS	
NO.	DATE
BY	REVISIONS
DATE: 11/8/12	
SCALE: N.T.S.	
DWG. BY: JK	
CHK. BY: LFS	
DRAWING NO.: TX-4278	
SHEET 5 OF 9	

R:\A - Projects\Project Folders\Proj 1601 - 1700\PF 1676\ID. RWBC Drawings\TX-4278-79.dwg, 6.1

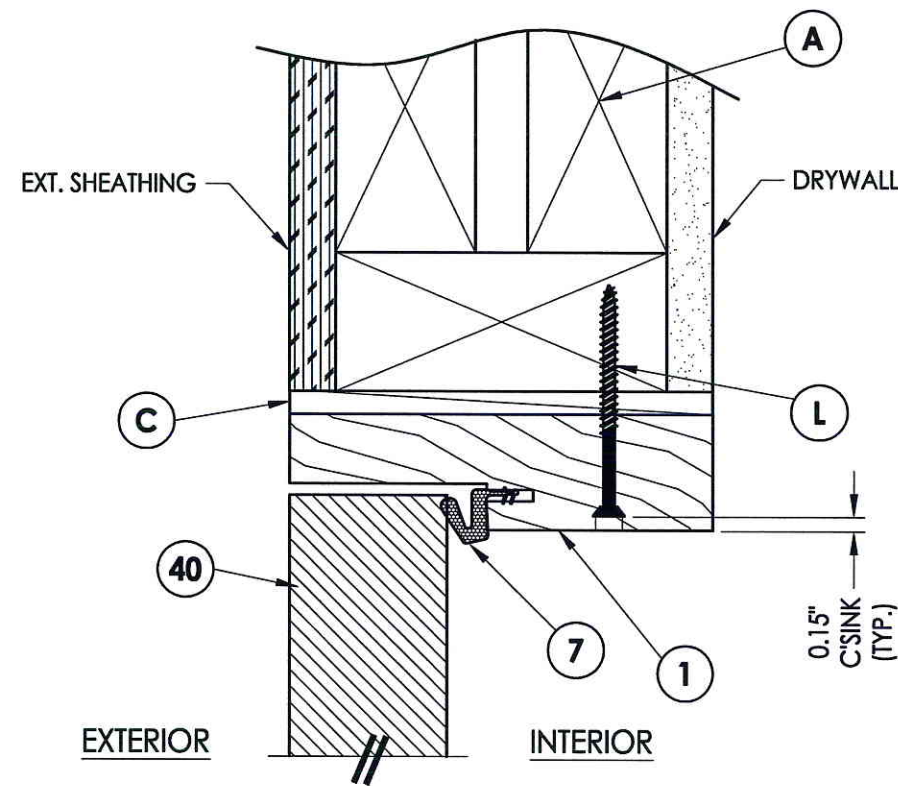

1 VERTICAL CROSS SECTION
6 Outswing shown - inswing also approved

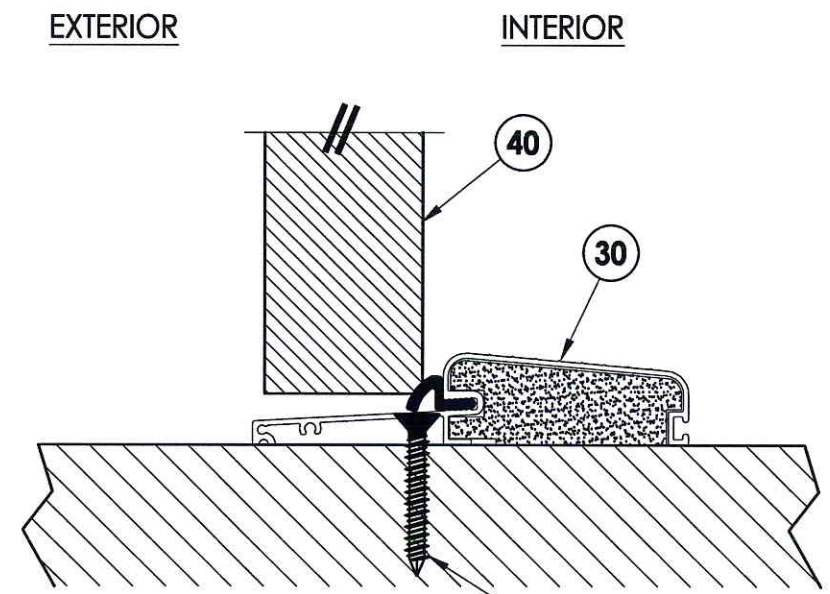

2 VERTICAL CROSS SECTION
6 Outswing configuration

J WOOD
D CONCRETE

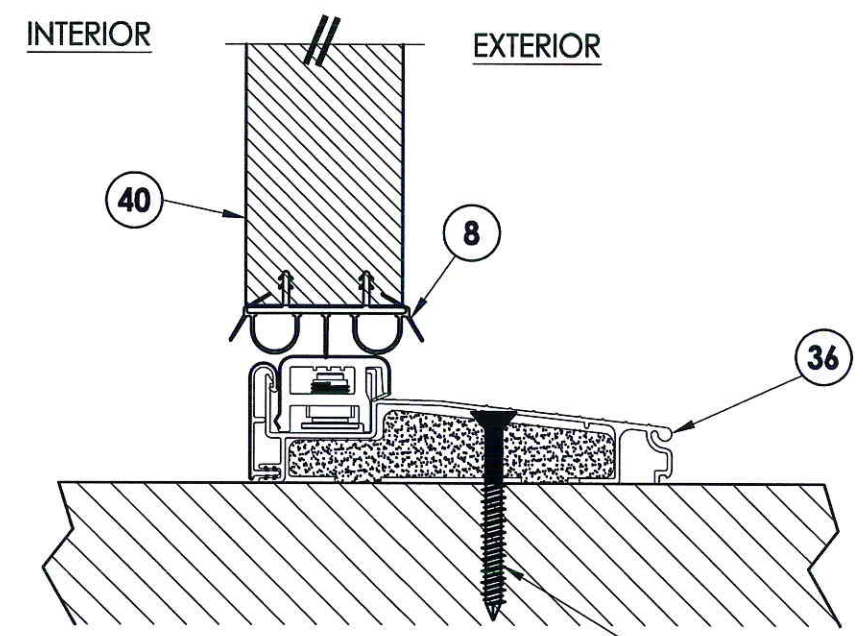

3 VERTICAL CROSS SECTION
6 Inswing configuration

J WOOD
D CONCRETE



Documents Prepared By: Lyndon F. Schmidt, P.E.
 TEXAS P.E. #104123

RW BUILDING CONSULTANTS, INC.
 P.O. Box 230 Valrico FL 33595
 Phone No.: 813.659.9197

TEXAS BOARD OF PROFESSIONAL ENGINEERS
 CERTIFICATE OF REGISTRATION # F-11852

PRODUCT: FIBERGLASS DOOR
 PART OR ASSEMBLY: VERTICAL CROSS SECTIONS

NO.	DATE	BY	REVISIONS

DATE: 11/8/12
 SCALE: N.T.S.
 DWG. BY: JK
 CHK. BY: LFS
 DRAWING NO.: TX-4278
 SHEET 6 OF 9

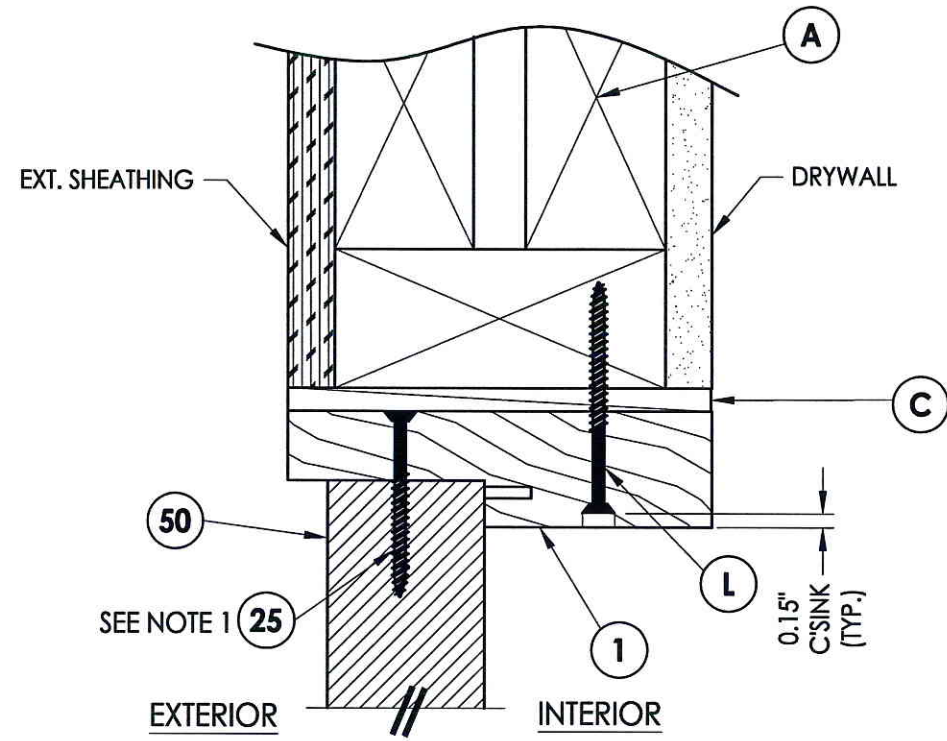

1
7 **VERTICAL CROSS SECTION**
Outswing shown - Inswing also approved

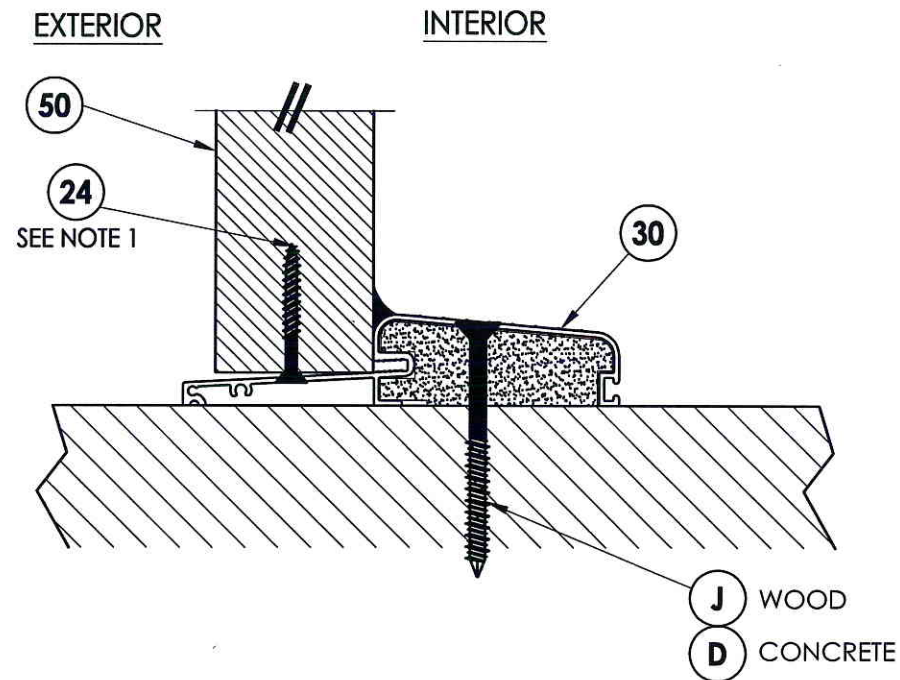

2
7 **VERTICAL CROSS SECTION**
Outswing shown

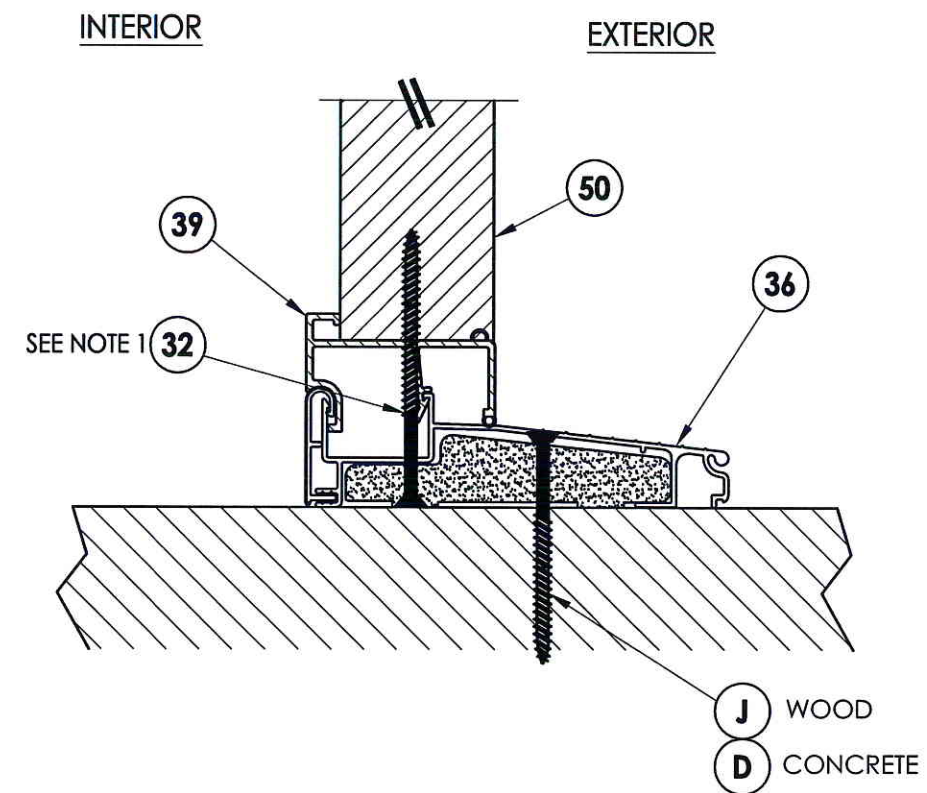

3
7 **VERTICAL CROSS SECTION**
Inswing shown

NOTE:
1. Sidelite panel screws located 6" from each end (2 total).

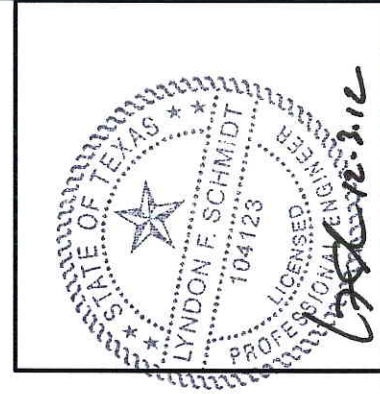

Documents Prepared By: Lyndon F. Schmidt, P.E.
TEXAS P.E. #104123

RW BUILDING CONSULTANTS, INC.
P.O. Box 230 Valrico FL 33595
Phone No.: 813.659.9197
TEXAS BOARD OF PROFESSIONAL ENGINEERS
CERTIFICATE OF REGISTRATION # F-11852

PRODUCT: FIBERGLASS DOOR
PART OR ASSEMBLY: VERTICAL CROSS SECTIONS

NO.	DATE	BY	REVISIONS

DATE: 11/8/12
SCALE: N.T.S.
DWG. BY: JK
CHK. BY: LFS
DRAWING NO.: TX-4278
SHEET 7 OF 9

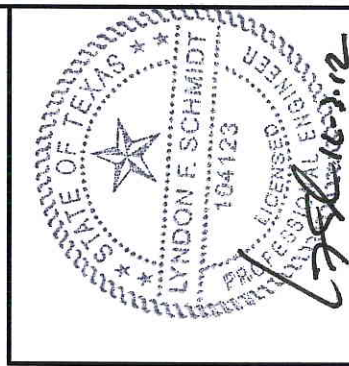

2X FRAMING TO BE DESIGNED BY THE ENGINEER OR ARCHITECT OF RECORD BASED ON WIND LOADS AND THE CLADDING BEING USED (TYP.).

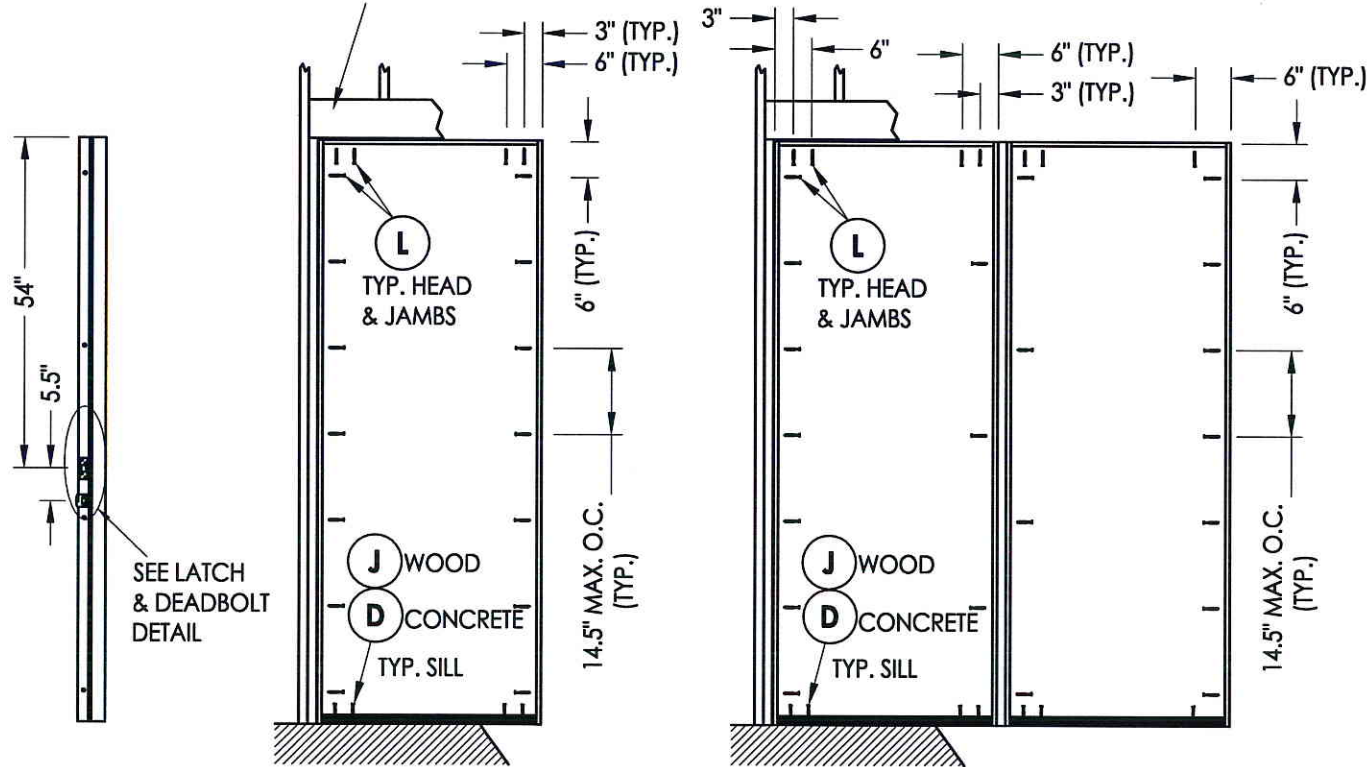

STRIKE JAMB

FRAME ANCHORING
X

FRAME ANCHORING
XO (shown)
OX (similar)

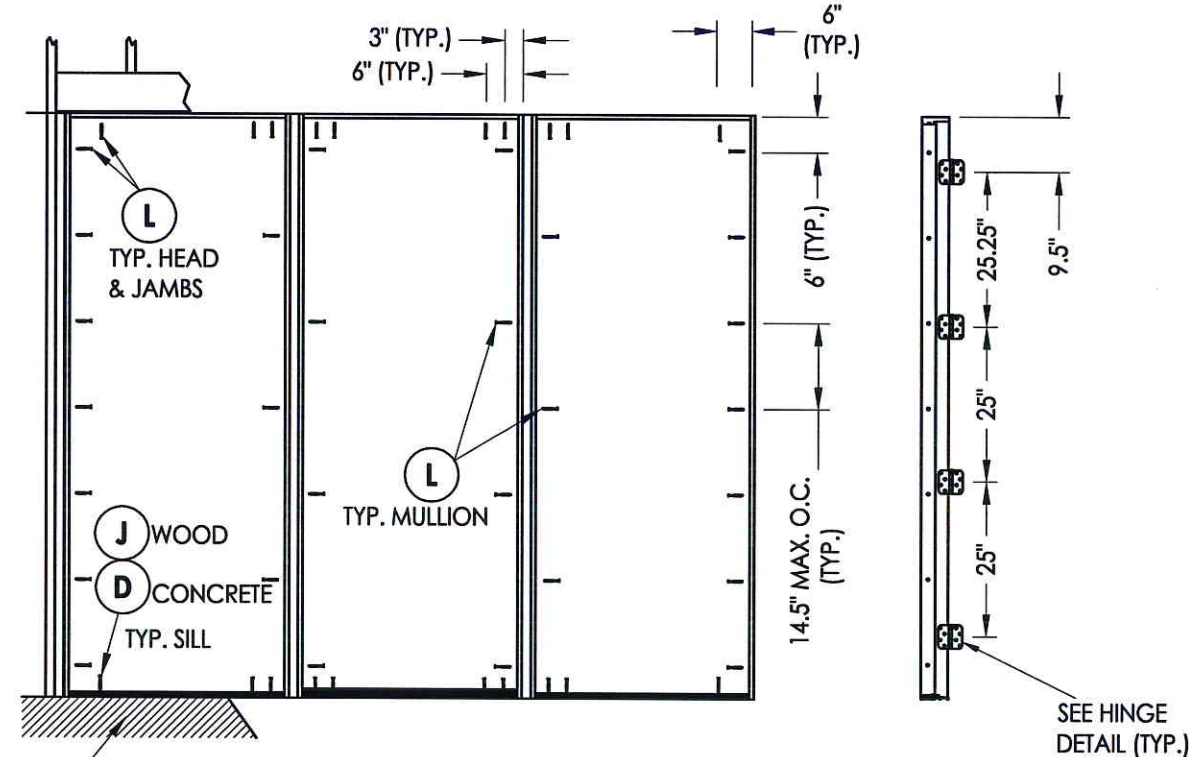

FLOOR SUBSTRATE MATERIAL (TYP.)
CONCRETE (MIN. 3000 PSI)
WOOD (G >= 0.42)

FRAME ANCHORING
OXO

HINGE JAMB

CONCRETE ANCHOR NOTES:

- Concrete anchor locations at the corners may be adjusted to maintain the min. edge distance to mortar joints.
- Concrete anchor locations noted as "MAX. ON CENTER" must be adjusted to maintain the min. edge distance to mortar joints, additional concrete anchors may be required to ensure the "MAX. ON CENTER" dimension are not exceeded.
- Concrete anchor table:

ANCHOR TYPE	ANCHOR SIZE	MIN. EMBEDMENT	MIN. CLEARANCE TO MASONRY EDGE	MIN. CLEARANCE TO ADJACENT ANCHOR
ITW TAPCON®	1/4"	1-3/4"	2-1/2"	3"
ELCO ULTRACON®	1/4"	1-3/4"	1"	3"

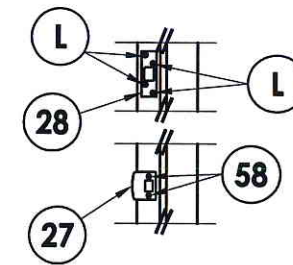

LATCH & DEADBOLT DETAIL
Security Strike

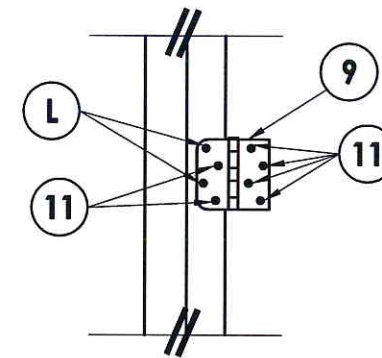

HINGE DETAIL

Documents Prepared By: Lyndon F. Schmidt, P.E.
TEXAS P.E. #104123

RW BUILDING CONSULTANTS, INC.
P.O. Box 230 Valrico FL 33595
Phone No.: 813.659.9197

TEXAS BOARD OF PROFESSIONAL ENGINEERS
CERTIFICATE OF REGISTRATION # F-11852

PRODUCT: FIBERGLASS DOOR
PART OR ASSEMBLY: FRAME ANCHORING

NO.	DATE	BY

DATE: 8/28/12
SCALE: N.T.S.
DWG. BY: JK
CHK. BY: LFS
DRAWING NO.: TX-4278
SHEET 8 OF 9

R:\A - Projects\Project Folders\Proj 1601 - 1700\PF 1676\D. RWBC Drawings\TX-4278-79.dwg, 9.1

BILL OF MATERIALS

ITEM #	DESCRIPTION	MATERIAL
B	2X FRAMING (G >= 0.42)	WOOD
C	1/4" MAX. SHIM SPACE	-
D	1/4" PFH ELCO OR ITW CONCRETE SCREW (1-3/4" MIN. EMB.)	STEEL
J	#10 X 3" PFH WOOD SCREW (1-1/2" MIN. EMB.)	STEEL
L	#10 X 2-1/2" PFH WOOD SCREW (1.15" MIN. EMB.)	STEEL
1	HEAD & JAMB (FINGER-JOINT PINE)	WOOD
7	WEATHERSTRIP (PE 650 - ENDURA)	FOAM
8	DOOR BOTTOM SWEEP	VINYL
9	4" HINGE	STEEL
11	#9 X 3/4" PFH WOOD SCREW	STEEL
24	#10 X 1-1/2" PFH WOOD SCREW	STEEL
25	#10 X 2" PFH WOOD SCREW	STEEL
27	LATCH STRIKE PLATE	STEEL
28	DEADBOLT STRIKE PLATE	STEEL
30	OUTSWING THRESHOLD	ALUM/COMP
32	#8 X 3" PFH WS	STEEL
36	INSWING THRESHOLD	ALUM/COMP
39	INSWING SIDELITE SEAT	PVC
40	DOOR PANEL - SEE DOOR PANEL DETAIL SHEET FOR DETAILS	-
50	SIDELITE PANEL - SEE SIDELITE PANEL DETAIL SHEET FOR DETAILS	-
58	#8 X 2-1/2" PFH WOOD SCREW	STEEL
88	2X MULLION REINFORCEMENT (G >= 0.55)	WOOD

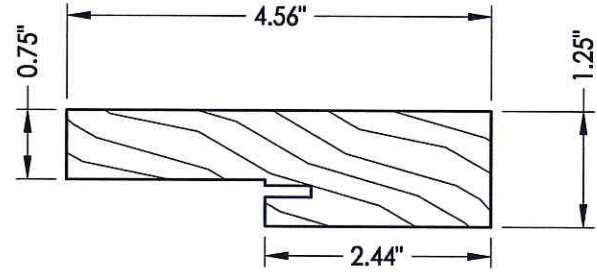

1 HEAD & JAMB
Wood

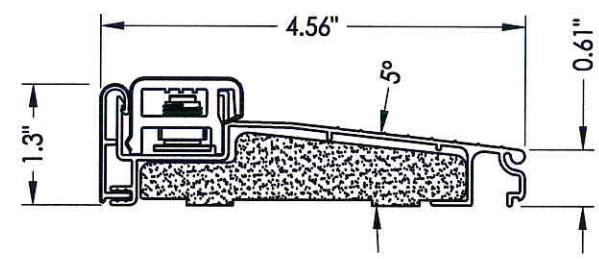

36 INSWING THRESHOLD
ENDURA ZAIL 4565
with Composite Substrate

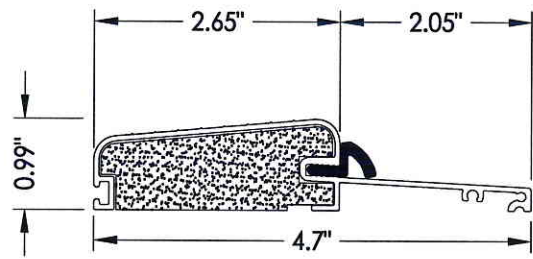

30 OUTSWING THRESHOLD
Columbia 775 Series
w/ Composite Substrate

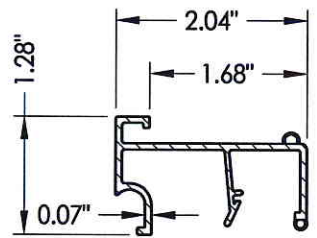

39 INSWING SIDELITE SEAT
ENDURA 60 SERIES

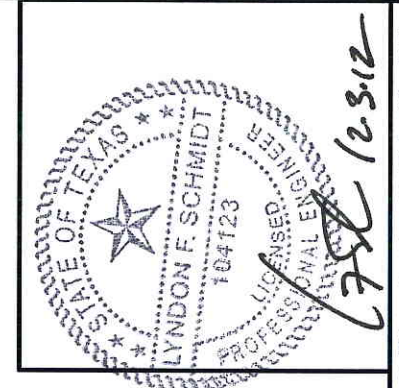

Documents Prepared By: Lyndon F. Schmidt, P.E.
TEXAS P.E. #104123

RW BUILDING CONSULTANTS, INC.
P.O. Box 230 Valrico FL, 33595
Phone No.: 813.659.9197
TEXAS BOARD OF PROFESSIONAL ENGINEERS
CERTIFICATE OF REGISTRATION # F-11852

PRODUCT: FIBERGLASS DOOR
PART OR ASSEMBLY: BILL OF MATERIALS & COMPONENTS

NO.	DATE	BY	REVISIONS

DATE: 11/8/12
SCALE: N.T.S.
DWG. BY: JK
CHK. BY: LFS
DRAWING NO.: TX-4278
SHEET 9 of 9