

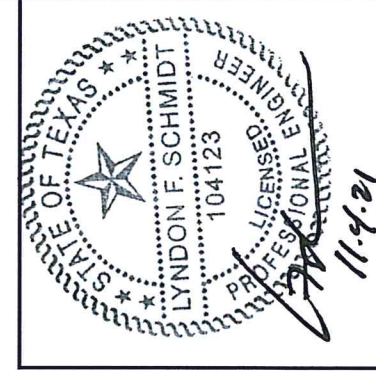

215 EAST ROOSEVELT AVE.
ZEELAND, MI 49464

Distributed by: Builders FirstSource
302 North Mile 2-1/2 East
Mercedes, TX 78570

FIBERGLASS ENTRY DOOR INSWING / OUTSWING "IMPACT"

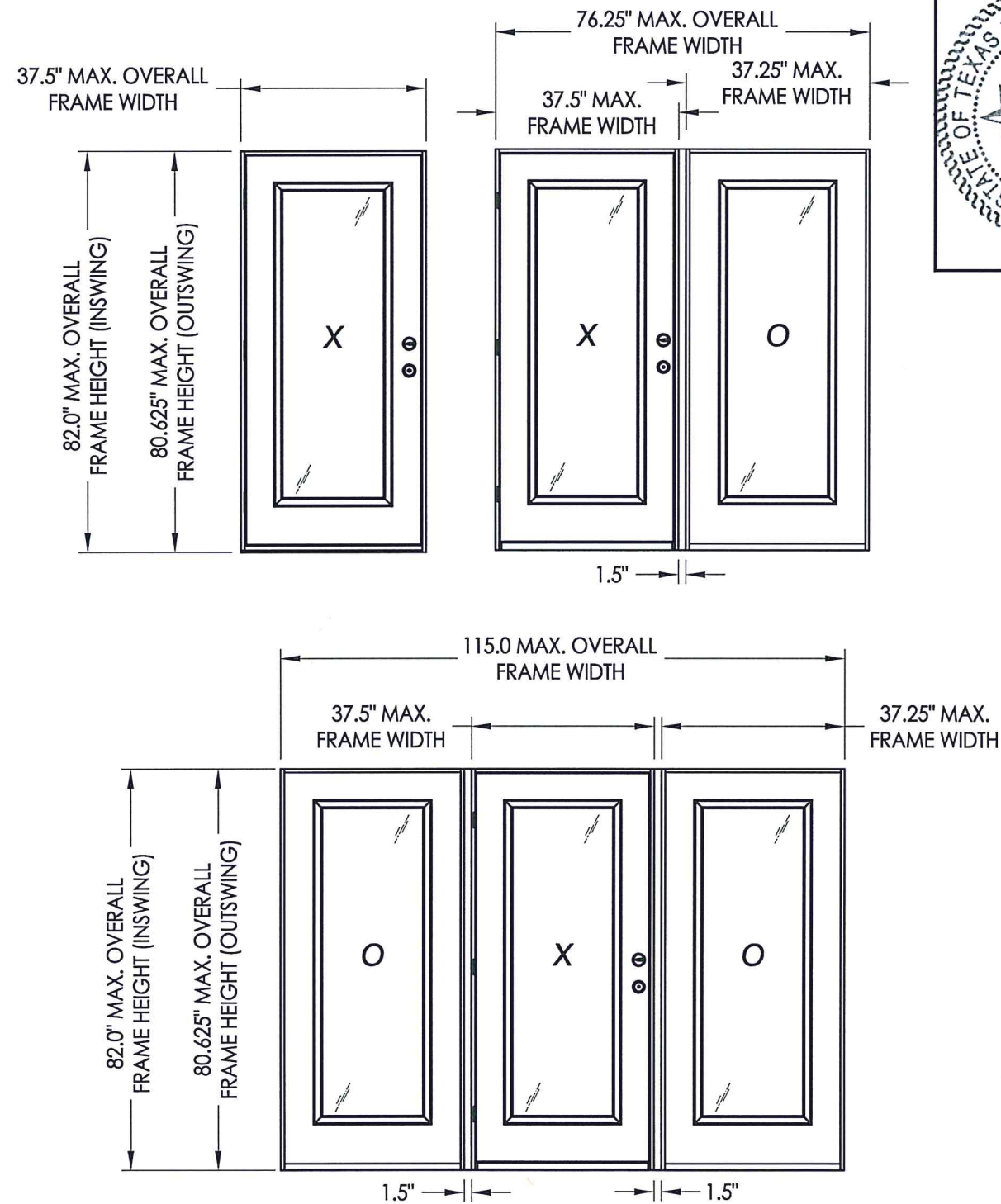

Documents Prepared By: Lyndon F. Schmidt, P.E.
TEXAS P.E. #104123
RW BUILDING CONSULTANTS, INC.
P.O. Box 230 Valrico FL 33595
Phone No.: 813.659.9197
TEXAS BOARD OF PROFESSIONAL ENGINEERS
CERTIFICATE OF REGISTRATION # F-11852

EVALUATED FOR USE IN THE STATE OF TEXAS

TDI DR-634

The Fiberglass Door system described herein complies with the 2018 International Residential Code (IRC), Sections R301 & R609 and the 2018 International Building Code (IBC), Sections 1404.13, 1609, 1709.5, 2403 and 2404 subject to the following conditions:

1. Anchors shall be as listed and spaced as shown in the details. Anchor embedment to base material shall be beyond wall dressing or stucco.
2. This system has been tested and evaluated as a large missile impact protective system for installation in areas that require wind borne debris protection. This product meets missile level "D" as defined in ASTM E 1996.
3. Allowable design pressure requirements must be equal to or less than the design pressure rating shown in the design pressure chart, sheet 1 of this drawing.
4. Conditions not covered by this drawing are subject to further engineering analysis.

TABLE OF CONTENTS

SHEET #	DESCRIPTION
1	Typical elevations, design pressures & general notes
2	Door/Sidelite panel details
3	Lite frame and glazing details
4	Elevations
5	Horizontal cross sections
6	Vertical cross sections
7	Vertical cross sections
8	Frame anchoring
9	Bill of materials & components

CONFIGURATION	MAX. FRAME DIMENSION	DESIGN PRESSURE (PSF) INSWING		DESIGN PRESSURE (PSF) OUTSWING	
		POSITIVE	NEGATIVE	POSITIVE	NEGATIVE
X	37.5" x 82.0"	+50.0	-50.0	+50.0	-50.0
OX/XO	76.25" x 82.0"	+50.0	-50.0	+50.0	-50.0
OXO	115.0" x 82.0"	+50.0	-50.0	+50.0	-50.0

PRODUCT:	FIBERGLASS DOOR	
PART OR ASSEMBLY:	TYPICAL ELEVATION, DESIGN PRESSURES & GENERAL NOTES	
NO.	DATE	BY
3	10/25/21	LFS
2	5/29/18	LFS
1	12/14/15	JK
REVISIONS		
DATE:	11/8/12	
SCALE:	N.T.S.	
DWG. BY:	JK	
CHK. BY:	LFS	
DRAWING NO.:	TX-4276	
SHEET	1	OF 9

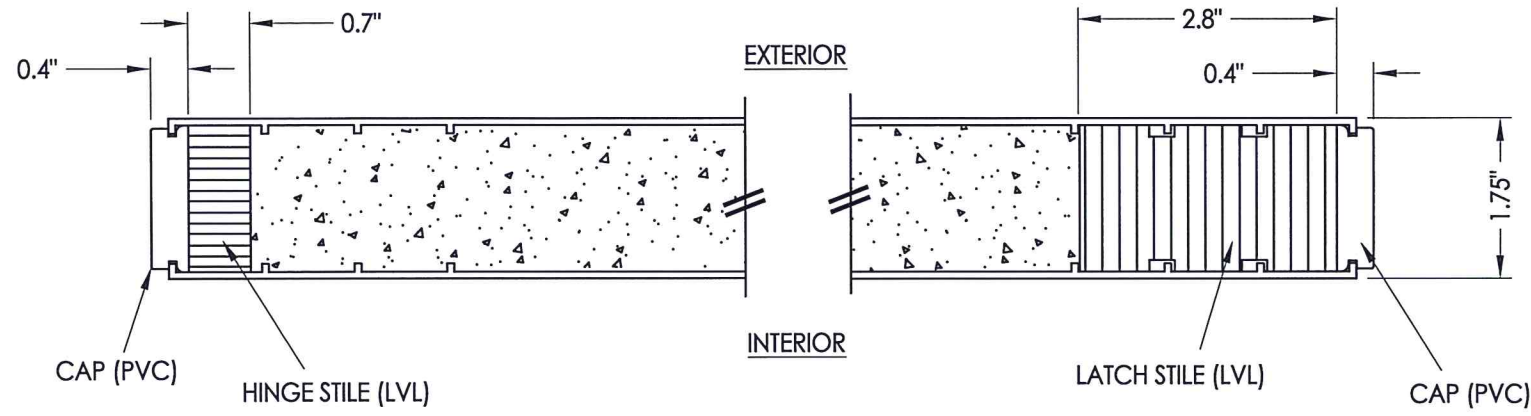

1
2 HORIZONTAL CROSS SECTION

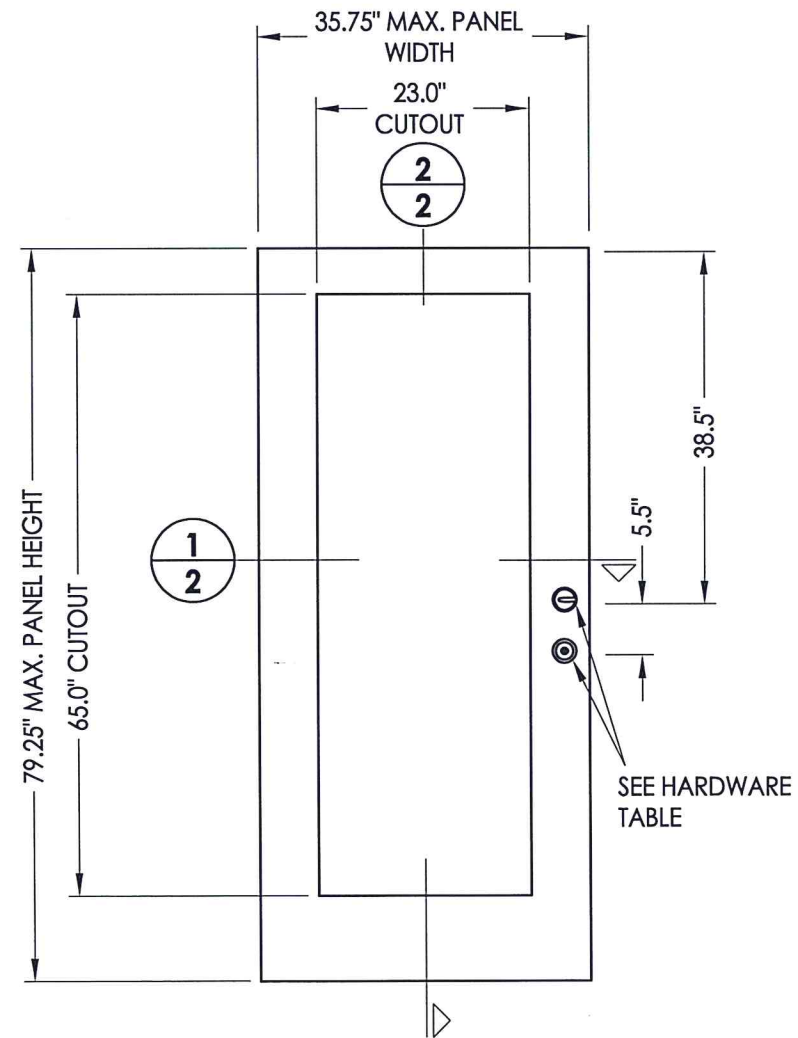

- 40** DOOR PANEL
Fiberglass (Plastpro)
- 50** SIDELITE PANEL
Fiberglass (Plastpro)

HARDWARE TABLE		
MANUFACTURER	MODEL	
KWIKSET	KNOB:	SIGNATURE SERIES
	DEADBOLT:	SIGNATURE SERIES (980)

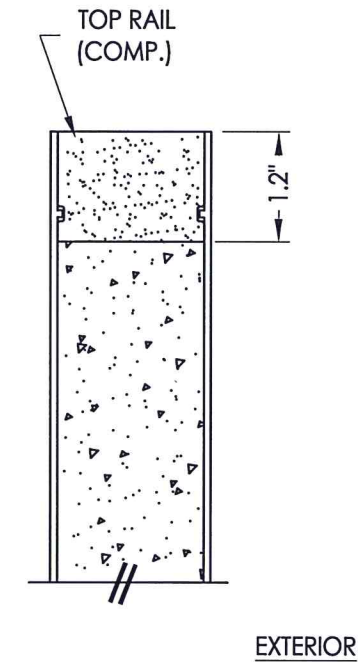

2
2 VERTICAL CROSS SECTION



Documents Prepared By: Lyndon F. Schmidt, P.E.
TEXAS P.E. #104123

RW BUILDING CONSULTANTS, INC.
P.O. Box 230 Valrico FL, 33595
Phone No.: 813.659.9197

TEXAS BOARD OF PROFESSIONAL ENGINEERS
CERTIFICATE OF REGISTRATION # F-11852

PRODUCT:	FIBERGLASS DOOR
PART OR ASSEMBLY:	DOOR/SIDELITE PANEL DETAILS

NO.	DATE	BY	REVISIONS
3	10/25/21	LFS	UPDATE TO 2018 IBC/IRC
2	5/29/18	LFS	ADD FLAT FRAME LITE PROFILE
1	12/14/15	JK	ADD H.S. GLAZING OPTION

DATE:	11/8/12
SCALE:	N.T.S.
DWG. BY:	JK
CHK. BY:	LFS
DRAWING NO.:	TX-4276
SHEET	2 OF 9

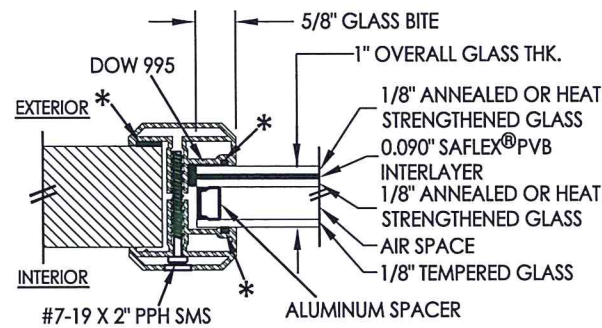

G1 GLAZING DETAIL
Flat Frame Profile

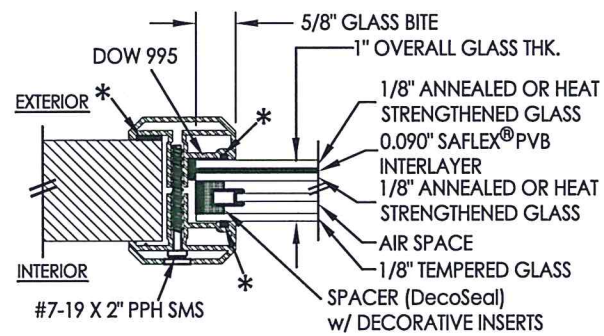

G3 GLAZING DETAIL
Flat Frame Profile

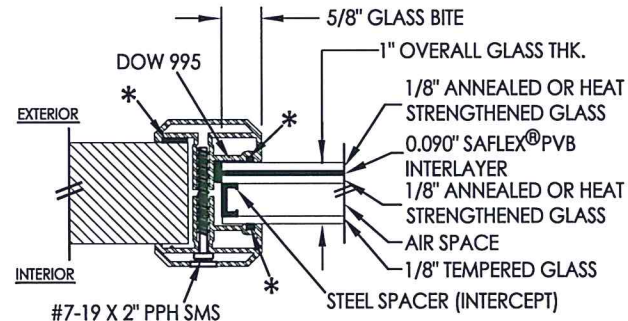

G2 GLAZING DETAIL
Flat Frame Profile

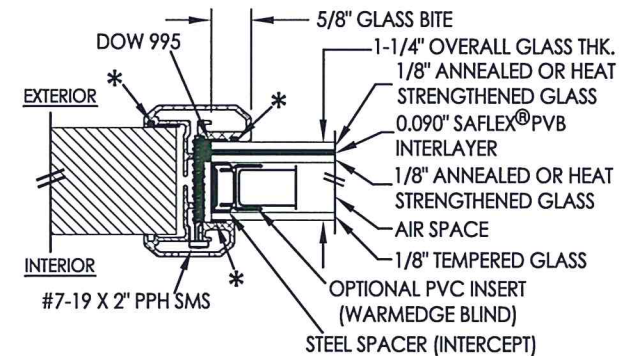

G4 GLAZING DETAIL
Flat Frame Profile
w/ Blinds Between Glass

* NON-STRUCTURAL
BACKBEDDING
(READI-SEAL)

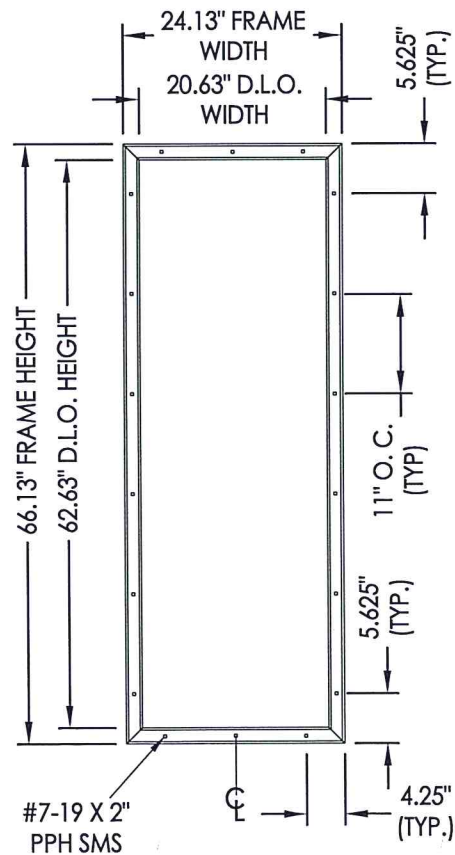

ODL LITE FRAME
"Flat Frame" Aluminum

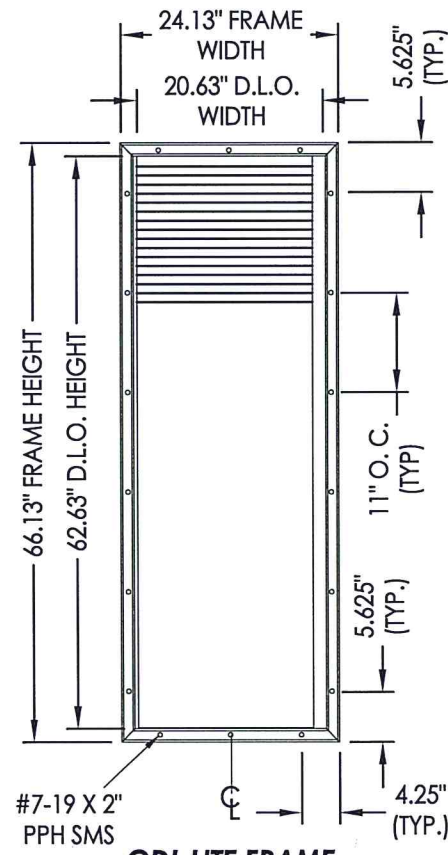

ODL LITE FRAME
"Flat Frame" Aluminum
w/ Blinds Between Glass

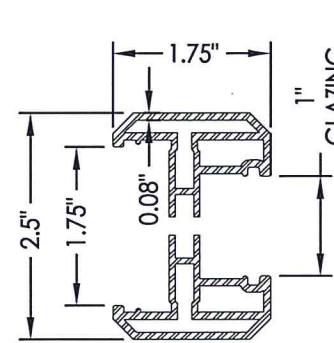

ODL LITE FLAT FRAME
1" GLAZING

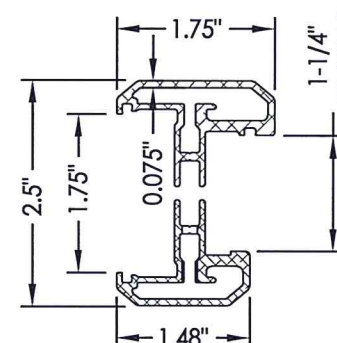

ODL LITE FLAT FRAME
1-1/4" GLAZING



Documents Prepared By: Lyndon F. Schmidt, P.E.
TEXAS P.E. #104123

RW BUILDING CONSULTANTS, INC.
P.O. Box 230 Valrico FL 33595
Phone No.: 813.659.9197

TEXAS BOARD OF PROFESSIONAL ENGINEERS
CERTIFICATE OF REGISTRATION # F-11852

PRODUCT: FIBERGLASS DOOR

PART OR ASSEMBLY: LITE FRAME & GLAZING DETAILS

NO.	DATE	BY	REVISIONS
3	10/25/21	LFS	UPDATE TO 2018 IBC/IRC
2	5/29/18	LFS	ADD FLAT FRAME LITE PROFILE
1	12/14/15	JK	ADD H.S. GLAZING OPTION

DATE: 11/8/12

SCALE: N.T.S.

DWG. BY: JK

CHK. BY: LFS

DRAWING NO.: TX-4276

SHEET 3 of 9

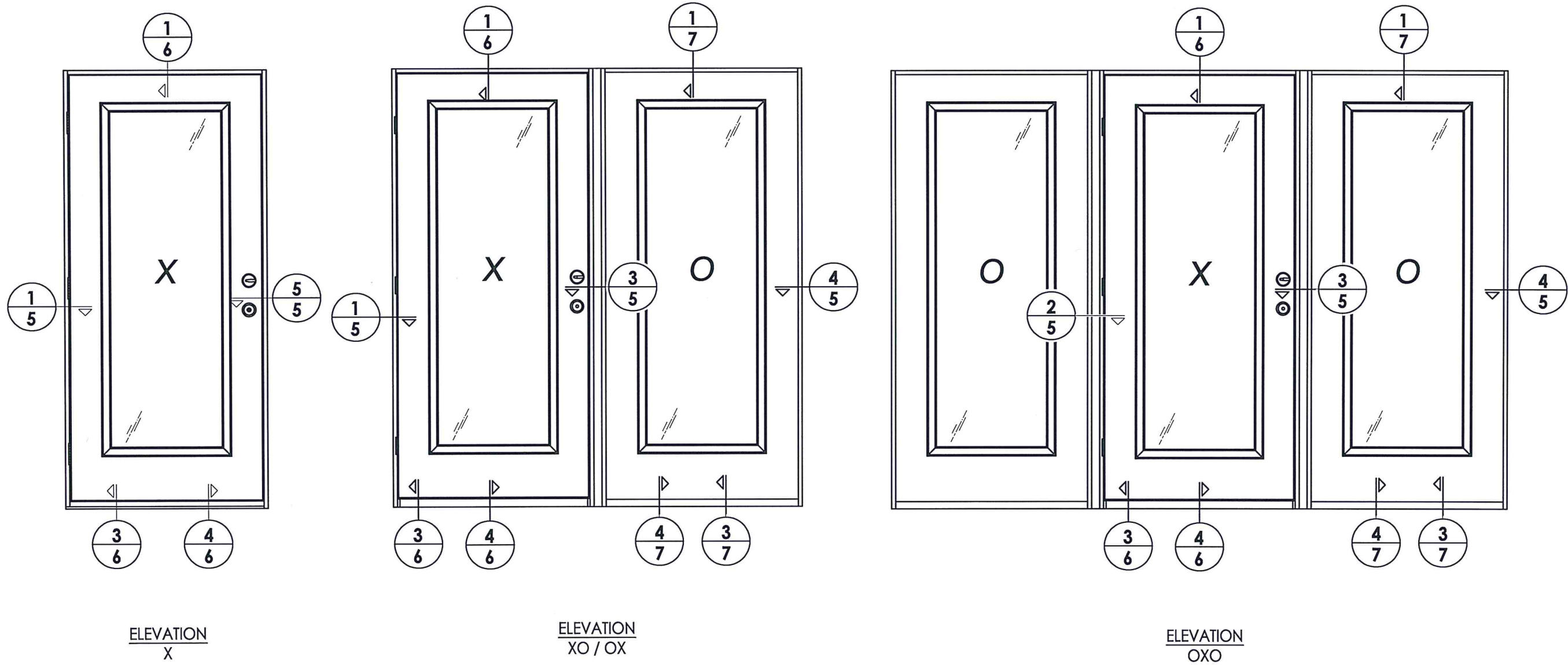

ELEVATION
X

ELEVATION
XO / OX

ELEVATION
OXO

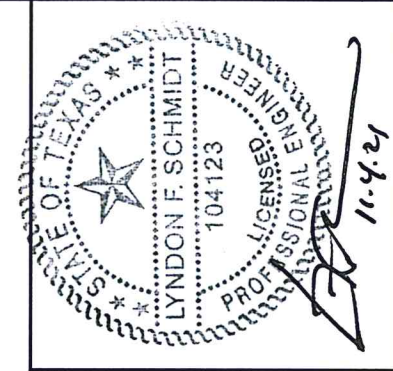

Documents Prepared By: Lyndon F. Schmidt, P.E.
TEXAS P.E. #104123

RW BUILDING CONSULTANTS, INC.
P.O. Box 230 Vairico FL, 33595
Phone No.: 813.659.9197

TEXAS BOARD OF PROFESSIONAL ENGINEERS
CERTIFICATE OF REGISTRATION # F-11852

PRODUCT: FIBERGLASS DOOR

PART OR ASSEMBLY: ELEVATIONS

NO.	DATE	REVISIONS
3	10/25/21	UPDATE TO 2018 IBC/IRC
2	5/29/18	ADD FLAT FRAME LITE PROFILE
1	12/14/15	ADD H.S. GLAZING OPTION
		DATE
		BY

DATE: 11/8/12

SCALE: N.T.S.

DWG. BY: JK

CHK. BY: LFS

DRAWING NO.: TX-4276

SHEET 4 OF 9

Z:\Clients\ODL, Inc. PERMANENT\B - Texas Dept of Ins\TDL - 634\Drawings\TX-4276-77.dwg

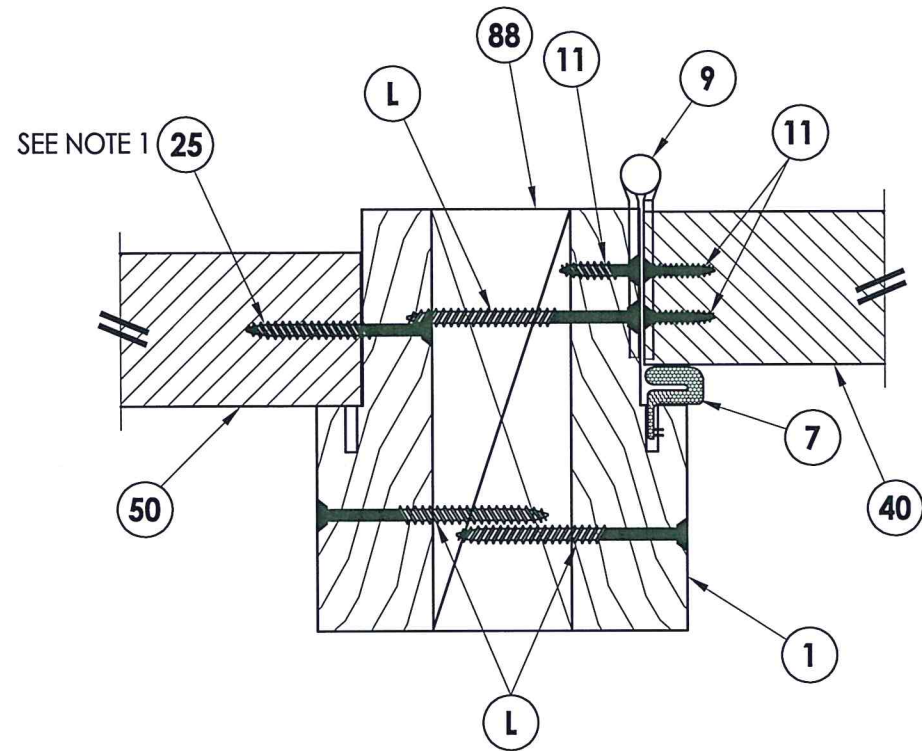

2 HORIZONTAL CROSS SECTION
5 Outwing shown - Inswing also approved

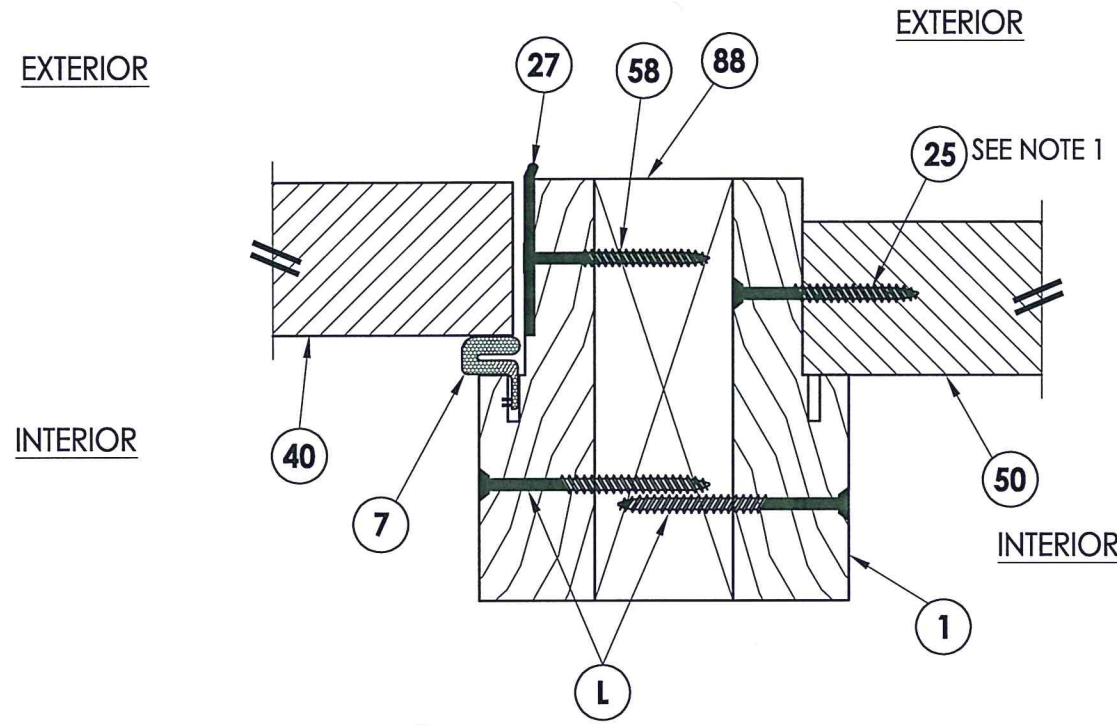

3 HORIZONTAL CROSS SECTION
5 Outwing shown - Inswing also approved

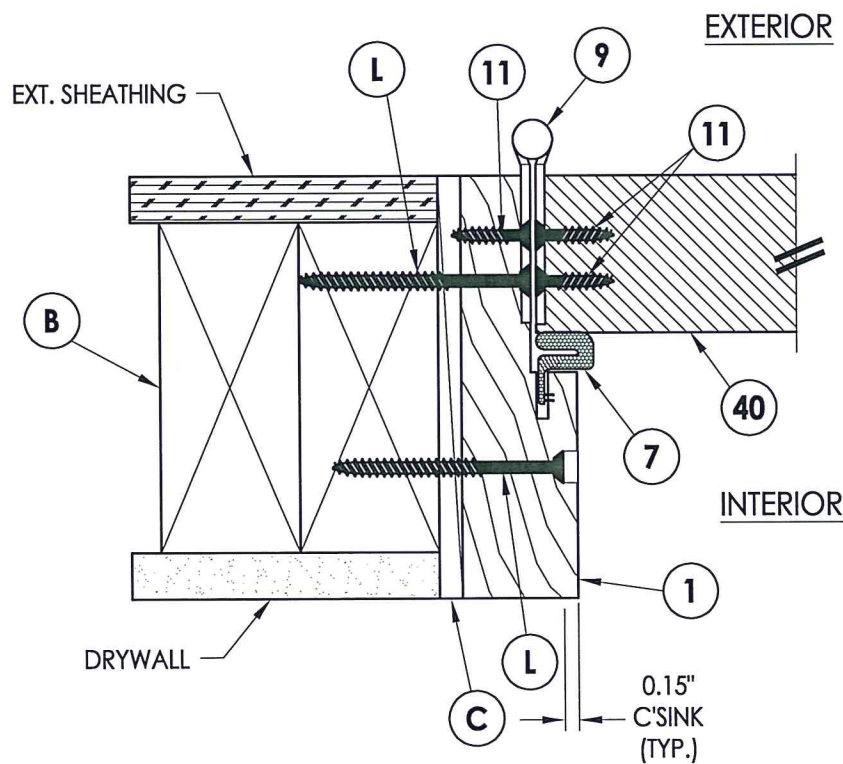

1 HORIZONTAL CROSS SECTION
5 Outwing shown - Inswing also approved

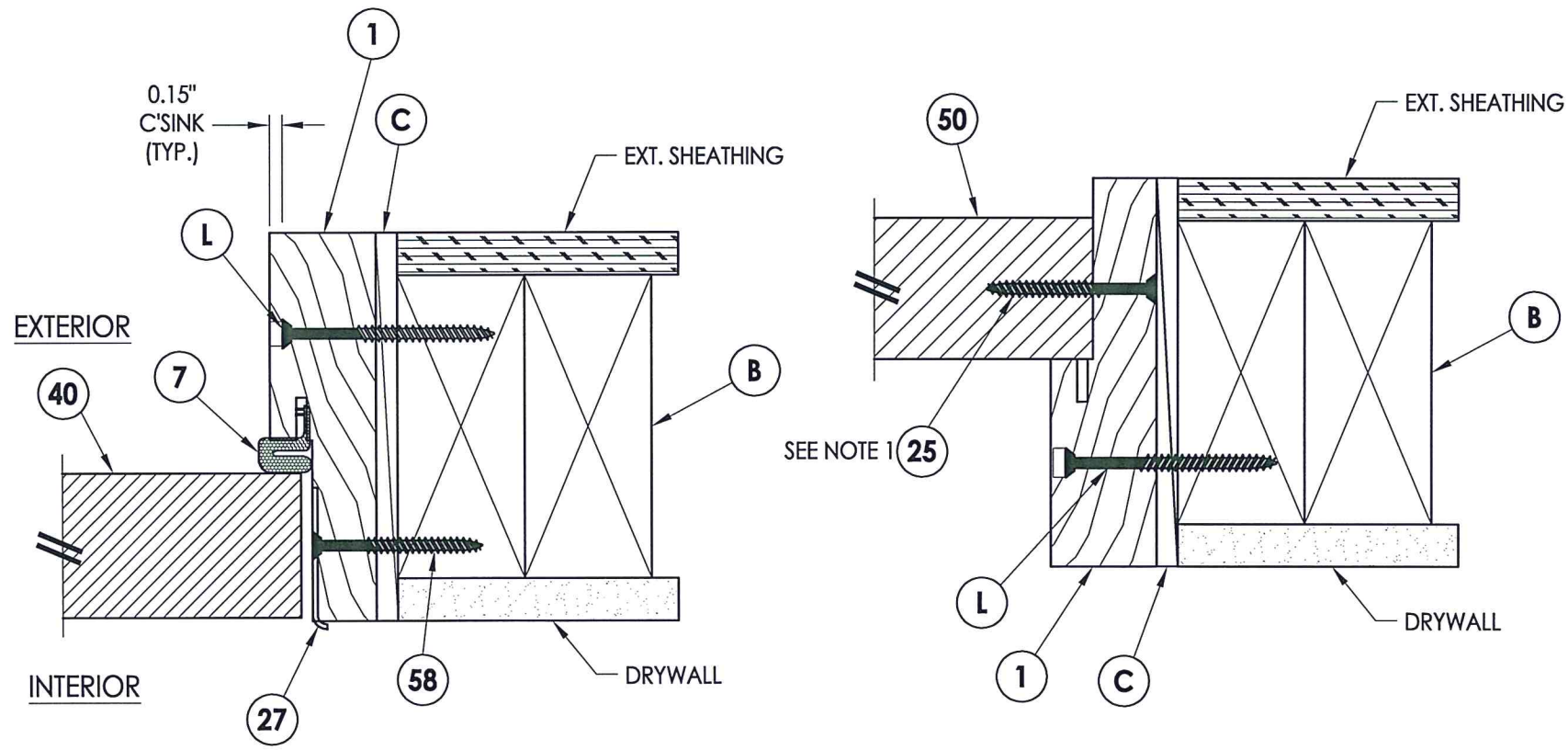

5 HORIZONTAL CROSS SECTION
5 Inswing shown - inswing also approved

4 HORIZONTAL CROSS SECTION
5 Outwing shown - Inswing also approved

NOTE:
 1. Sidelite panel screws located 6" from each end plus 4 more equally spaced (6 screws total).

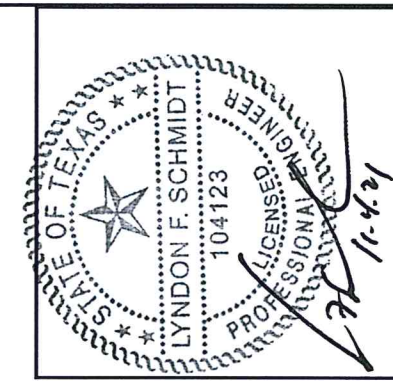

Documents Prepared By: Lyndon F. Schmidt, P.E.
 TEXAS P.E. #104123

RW BUILDING CONSULTANTS, INC.
 P.O. Box 230 Valrico FL, 33595
 Phone No.: 813.659.9197
 TEXAS BOARD OF PROFESSIONAL ENGINEERS
 CERTIFICATE OF REGISTRATION # F-11852

PRODUCT: FIBERGLASS DOOR
 PART OR ASSEMBLY: HORIZONTAL CROSS SECTIONS

NO.	DATE	REVISIONS
3	10/25/21	UPDATE TO 2018 IBC/IRC
2	5/29/18	ADD FLAT FRAME LITE PROFILE
1	12/14/15	ADD H.S. GLAZING OPTION

DATE: 11/8/12
 SCALE: N.T.S.
 DWG. BY: JK
 CHK. BY: LFS
 DRAWING NO.: TX-4276
 SHEET 5 OF 9

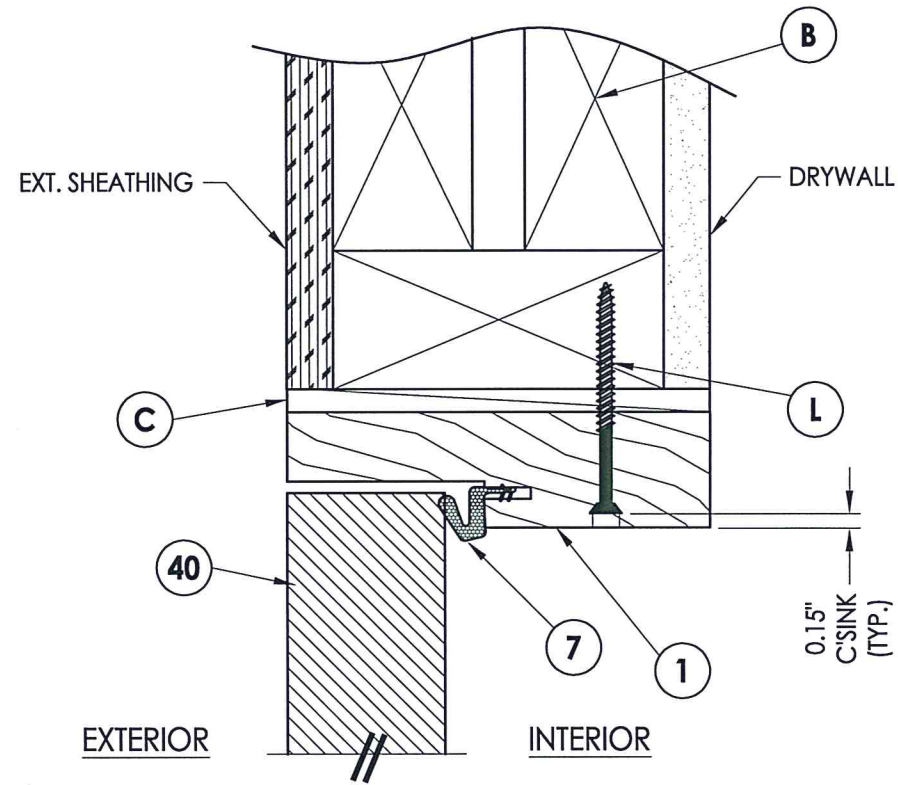

1 VERTICAL CROSS SECTION
 6 Outswing shown - inswing also approved

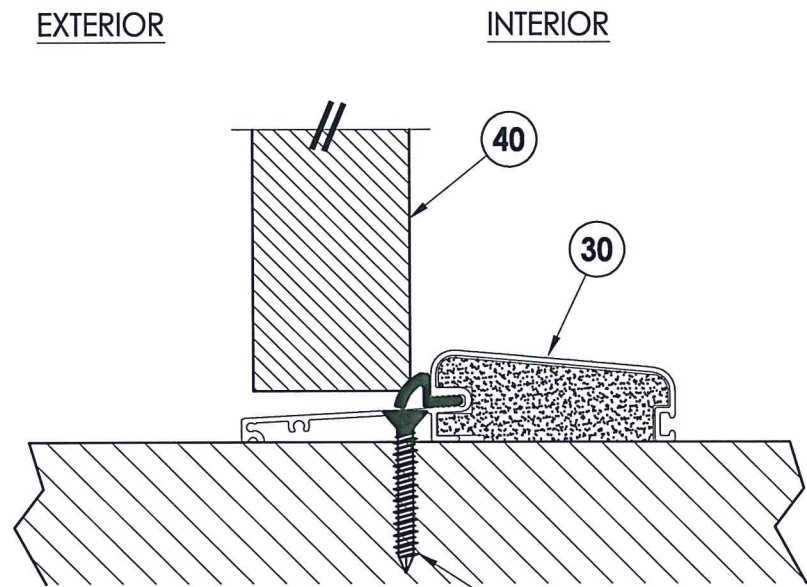

2 VERTICAL CROSS SECTION
 6 Outswing configuration

J WOOD
D CONCRETE

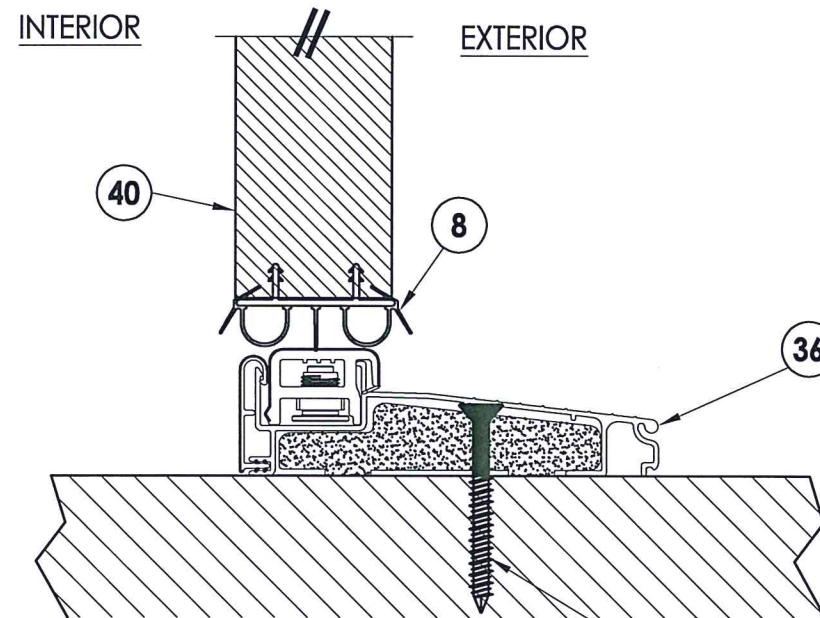

3 VERTICAL CROSS SECTION
 6 Inswing configuration

J WOOD
D CONCRETE

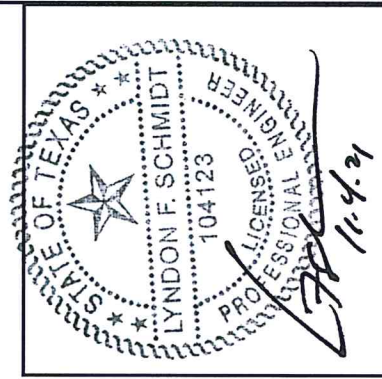

Documents Prepared By: Lyndon F. Schmidt, P.E.
 TEXAS P.E. #104123

RW BUILDING CONSULTANTS, INC.
 P.O. Box 230 Valrico FL 33595
 Phone No.: 813.659.9197
 TEXAS BOARD OF PROFESSIONAL ENGINEERS
 CERTIFICATE OF REGISTRATION # F-11852

PRODUCT: FIBERGLASS DOOR
 PART OR ASSEMBLY: VERTICAL CROSS SECTIONS

NO.	DATE	BY	REVISIONS
3	10/25/21	LFS	UPDATE TO 2018 IBC/IRC
2	5/29/18	LFS	ADD FLAT FRAME LITE PROFILE
1	12/14/15	JK	ADD H.S. GLAZING OPTION

DATE: 11/8/12
 SCALE: N.T.S.
 DWG. BY: JK
 CHK. BY: LFS
 DRAWING NO.: TX-4276
 SHEET 6 OF 9

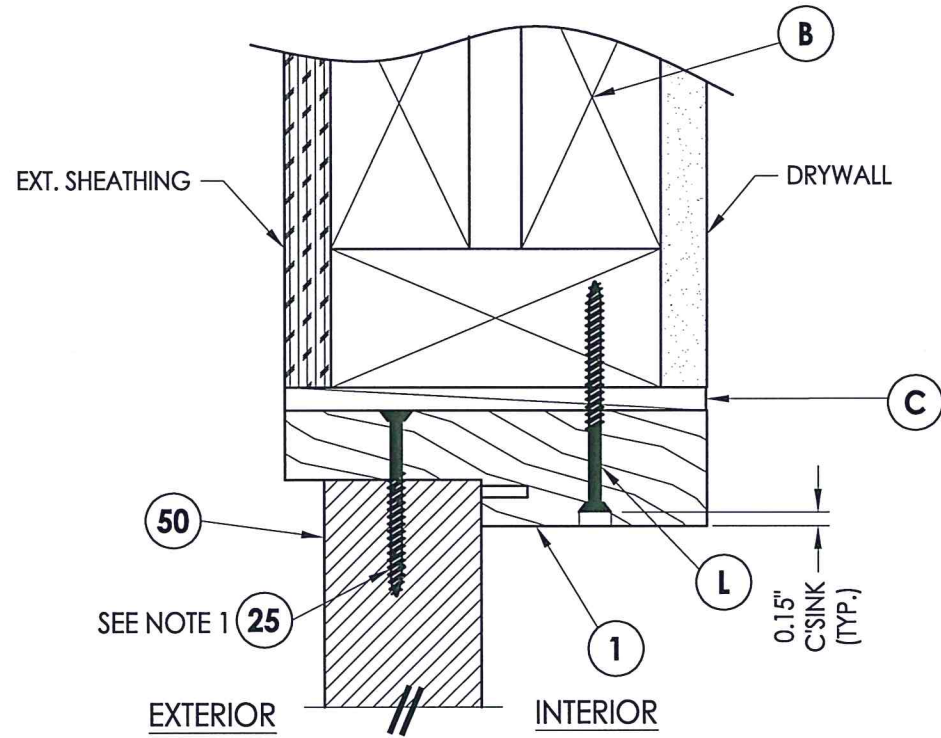

1 VERTICAL CROSS SECTION
7 Outswing shown - Inswing also approved

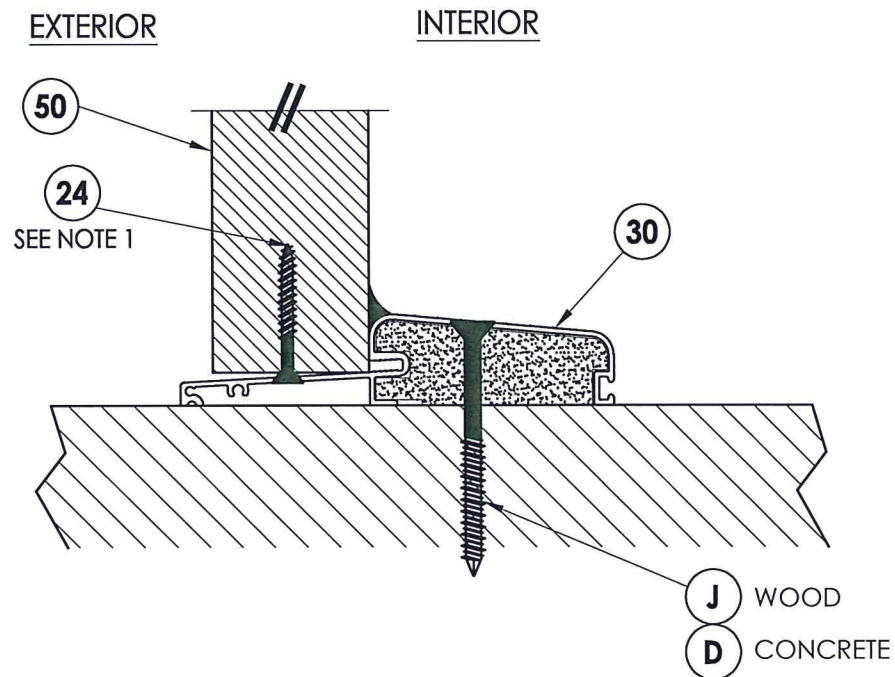

2 VERTICAL CROSS SECTION
7 Outswing shown

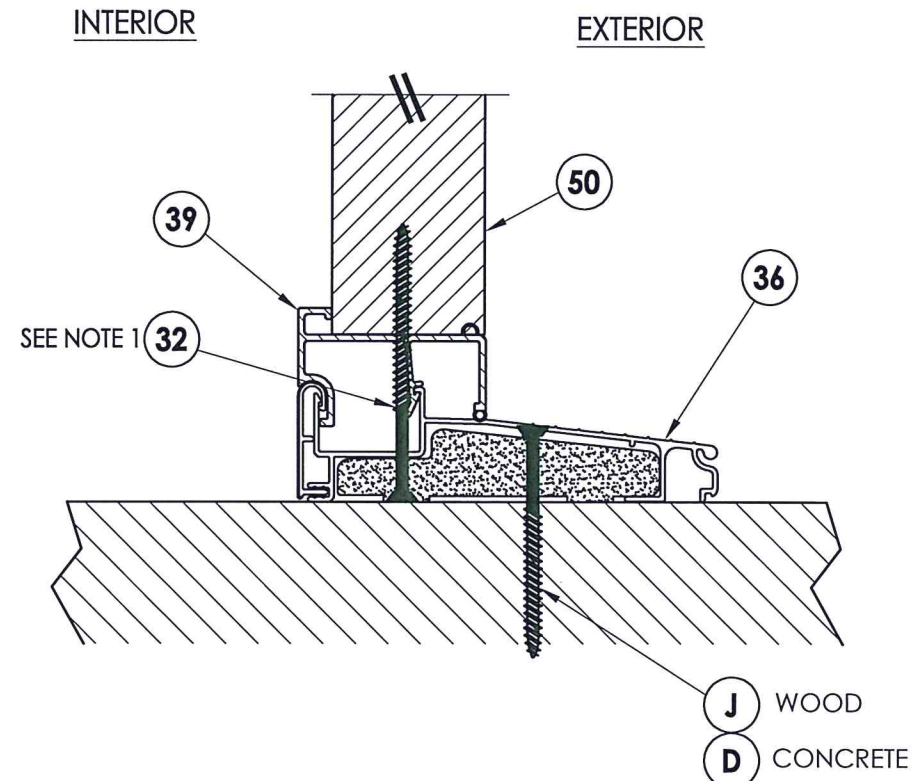

3 VERTICAL CROSS SECTION
7 Inswing shown

NOTE:
 1. Sidelite panel screws located 3" from each end (2 total).

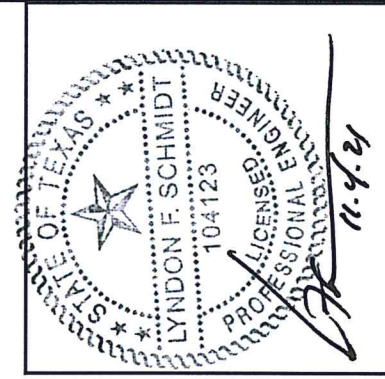

Documents Prepared By: Lyndon F. Schmidt, P.E.
 TEXAS P.E. #104123

RW BUILDING CONSULTANTS, INC.
 P.O. Box 230 Valrico FL, 33595
 Phone No.: 813.659.9197
 TEXAS BOARD OF PROFESSIONAL ENGINEERS
 CERTIFICATE OF REGISTRATION # F-11852

PRODUCT: FIBERGLASS DOOR
 PART OR ASSEMBLY: VERTICAL CROSS SECTIONS

NO.	DATE	REVISIONS
3	10/25/21	UPDATE TO 2018 IBC/IRC
2	5/29/18	ADD FLAT FRAME LITE PROFILE
1	12/14/15	ADD H.S. GLAZING OPTION

DATE: 11/8/12
 SCALE: N.T.S.
 DWG. BY: JK
 CHK. BY: LFS
 DRAWING NO.: TX-4276
 SHEET 7 OF 9

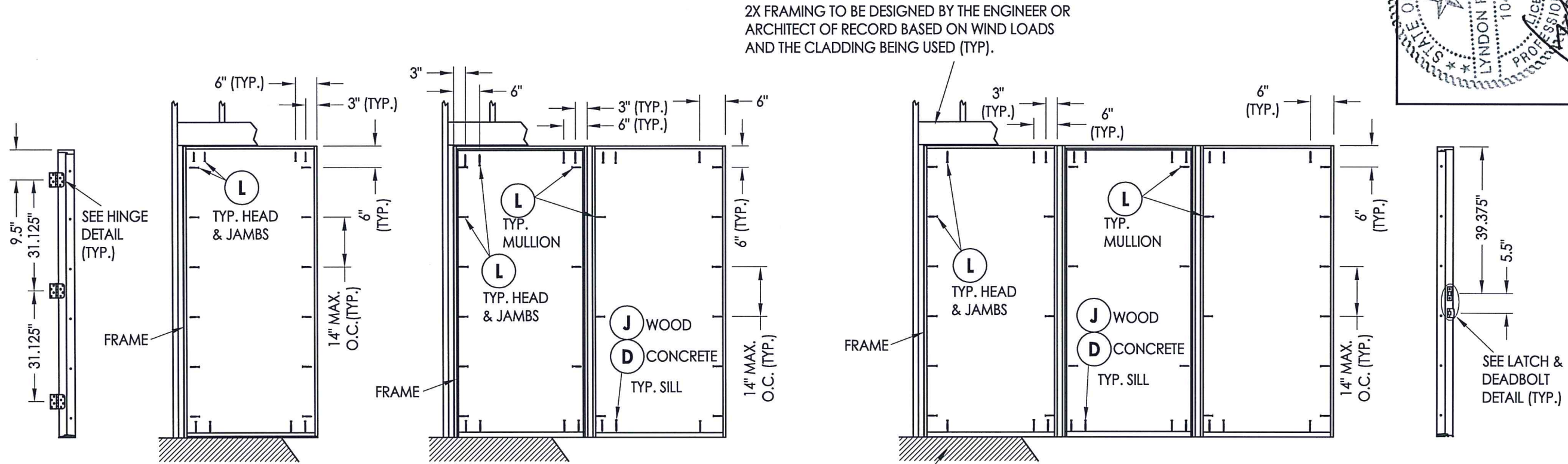

2X FRAMING TO BE DESIGNED BY THE ENGINEER OR ARCHITECT OF RECORD BASED ON WIND LOADS AND THE CLADDING BEING USED (TYP).



Documents Prepared By: Lyndon F. Schmidt, P.E.
TEXAS P.E. #104123

RW BUILDING CONSULTANTS, INC.
P.O. Box 230 Valrico FL 33595
Phone No.: 813.659.9197

TEXAS BOARD OF PROFESSIONAL ENGINEERS
CERTIFICATE OF REGISTRATION # F-11852

HINGE JAMB

FRAME ANCHORING
X

FRAME ANCHORING
XO (shown)
OX (similar)

FLOOR SUBSTRATE MATERIAL (TYP.)
CONCRETE (MIN. 3000 PSI)
WOOD (G >= 0.42)

FRAME ANCHORING
OXO

STRIKE JAMB

CONCRETE ANCHOR NOTES:

- Concrete anchor locations at the corners may be adjusted to maintain the min. edge distance to mortar joints.
- Concrete anchor locations noted as "MAX. ON CENTER" must be adjusted to maintain the min. edge distance to mortar joints, additional concrete anchors may be required to ensure the "MAX. ON CENTER" dimension are not exceeded.
- Concrete anchor table:

ANCHOR TYPE	ANCHOR SIZE	MIN. EMBEDMENT	MIN. CLEARANCE TO MASONRY EDGE	MIN. CLEARANCE TO ADJACENT ANCHOR
ITW TAPCON®	1/4"	1-3/4"	2-1/2"	3"
DeWALT ULTRACON®	1/4"	1-3/4"	1"	3"

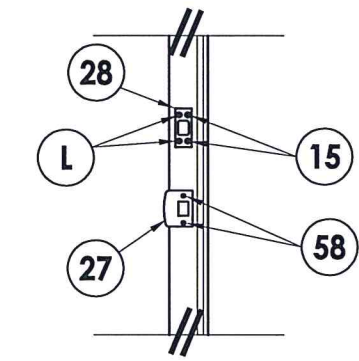
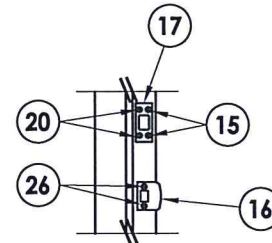

LATCH & DEADBOLT DETAIL

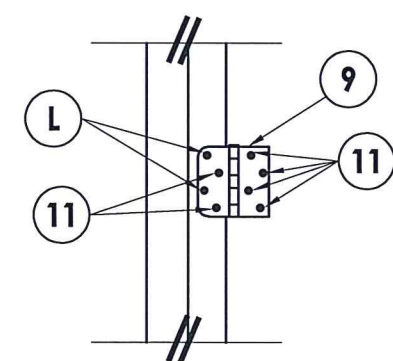

HINGE DETAIL

PRODUCT:	FIBERGLASS DOOR	
PART OR ASSEMBLY:	FRAME ANCHORING	
NO.	DATE	BY
3	10/25/21	LFS
2	5/29/18	LFS
1	12/14/15	JK
REVISIONS		
DATE:	8/28/12	
SCALE:	N.T.S.	
DWG. BY:	JK	
CHK. BY:	LFS	
DRAWING NO.:	TX-4276	
SHEET	8	OF 9

BILL OF MATERIALS

ITEM #	DESCRIPTION	MATERIAL
B	2X FRAMING (G >= 0.42)	WOOD
C	1/4" MAX. SHIM SPACE	-
D	1/4" PFH DeWALT OR ITW CONCRETE SCREW (1-3/4" MIN. EMB.)	STEEL
J	#10 X 3" PFH WOOD SCREW (1-1/2" MIN. EMB.)	STEEL
L	#10 X 2-1/2" PFH WOOD SCREW (1.15" MIN. EMB.)	STEEL
1	HEAD & JAMB (FINGER-JOINT PINE)	WOOD
7	WEATHERSTRIP (PE 650 - ENDURA)	FOAM
8	DOOR BOTTOM SWEEP	VINYL
9	4" HINGE	STEEL
11	#9 X 3/4" PFH WOOD SCREW	STEEL
15	#8 X 1/2" PFH WOOD SCREW	STEEL
24	#10 X 1-1/2" PFH WOOD SCREW	STEEL
25	#10 X 2" PFH WOOD SCREW	STEEL
27	LATCH STRIKE PLATE	STEEL
28	DEADBOLT STRIKE PLATE	STEEL
30	OUTSWING THRESHOLD	ALUM/COMP
32	#8 X 3" PFH WS	STEEL
36	INSWING THRESHOLD	ALUM/COMP
39	INSWING SIDELITE SEAT	PVC
40	DOOR PANEL - SEE DOOR PANEL DETAIL SHEET FOR DETAILS	-
50	SIDELITE PANEL - SEE SIDELITE PANEL DETAIL SHEET FOR DETAILS	-
58	#8 X 2-1/2" PFH WOOD SCREW	STEEL
88	2X MULLION REINFORCEMENT (G >= 0.55)	WOOD

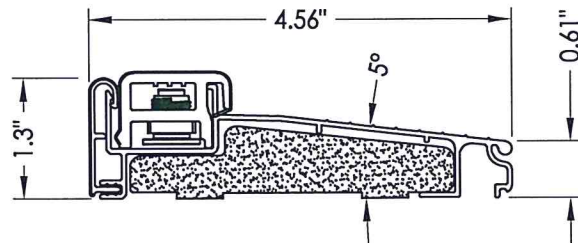

36 INSWING THRESHOLD
ENDURA ZAIL 4565
with Composite Substrate

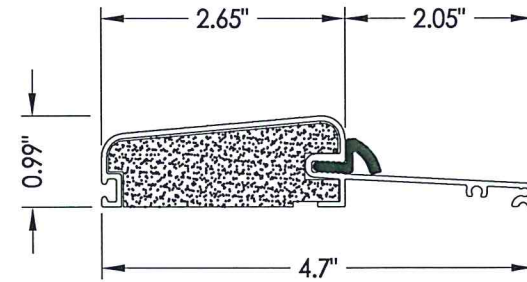

30 OUTSWING THRESHOLD
Columbia 775 Series
w/ Composite Substrate

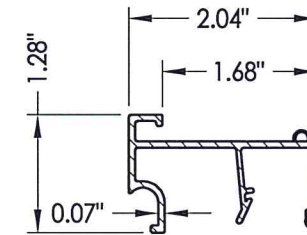

39 INSWING SIDELITE SEAT
ENDURA 60 SERIES

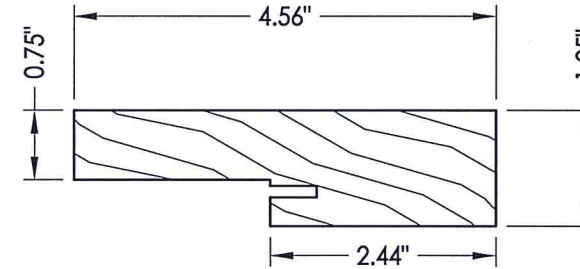

1 HEAD & JAMB
Wood

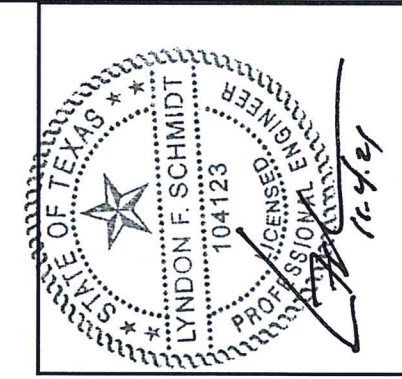

Documents Prepared By: Lyndon F. Schmidt, P.E.
TEXAS P.E. #104123

RW BUILDING CONSULTANTS, INC.
P.O. Box 250 Valrico FL, 33585
Phone No.: 813.659.9197
TEXAS BOARD OF PROFESSIONAL ENGINEERS
CERTIFICATE OF REGISTRATION # F-11852

PRODUCT: FIBERGLASS DOOR
PART OR ASSEMBLY: BILL OF MATERIALS & COMPONENTS

NO.	DATE	REVISIONS
3	10/25/21	UPDATE TO 2018 IBC/IRC
2	5/29/18	ADD FLAT FRAME LITE PROFILE
1	12/14/15	ADD H.S. GLAZING OPTION

DATE: 11/8/12
SCALE: N.T.S.
DWG. BY: JK
CHK. BY: LFS
DRAWING NO.: TX-4276
SHEET 9 of 9