

THERMA TRU®

118 INDUSTRIAL DR., EDGERTON, OH 43517
TEL. (419)298-1740

CLASSIC CRAFT RUSTIC SINGLE "IMPACT" DOOR INSWING / OUTSWING

EVALUATED FOR USE IN THE STATE OF TEXAS

The Fiberglass Glazed Door described herein complies with the 2006 International Residential Code (IRC), Sections R301 & R613 and the 2006 International Building Code (IBC), Sections 1405.12, 1609, 1714.5, 2403 and 2404 (including Texas revisions) subject to the following conditions:

1. Anchors shall be as listed and spaced as shown in the details. Anchor embedment to base material shall be beyond wall dressing or stucco.
2. This system has been tested and evaluated as a large missile impact protective system for installation in the Seaward, Inland I and Inland II areas. This product meets missile level "D" as defined in ASTM E 1996.
3. Allowable design pressure requirements must be equal to or less than the design pressure rating shown in the design pressure chart, sheet 1 of this drawing.
4. Conditions not covered by this drawing are subject to further engineering analysis.

TABLE OF CONTENTS	
SHEET #	DESCRIPTION
1	TYPICAL ELEVATION, DESIGN PRESSURES & GENERAL NOTES
2	DOOR PANEL DETAILS (CLASSIC CRAFT RUSTIC)
3	HORIZONTAL CROSS SECTIONS
4	VERTICAL CROSS SECTIONS
5	FRAME ANCHORING
6	BILL OF MATERIALS & COMPONENTS

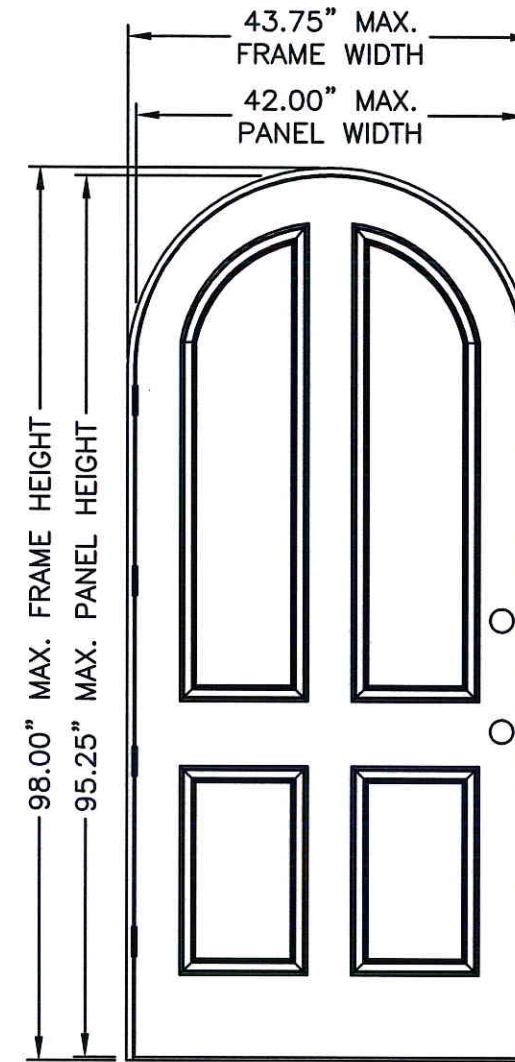

"CLASSIC CRAFT RUSTIC"

DOOR TYPE	SWING	OVERALL FRAME DIMENSION	DESIGN PRESSURE	
			POSITIVE	NEGATIVE
CLASSIC CRAFT RUSTIC	OUTSWING	43.75" X 96.50"	+65.0	-65.0
	INSWING	43.75" X 98.00"	+65.0	-65.0

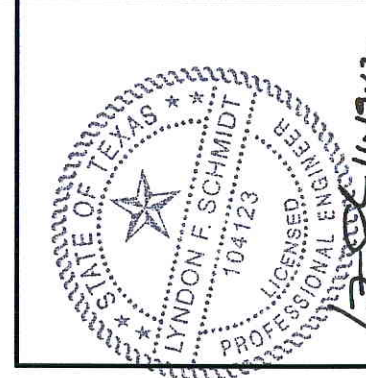

Documents Prepared By: Lyndon F. Schmidt, P.E.
TEXAS P.E. #104123

RW BUILDING CONSULTANTS, INC.
P.O. Box 230 Valrico FL 33595
Phone No.: 813.659.9197

TEXAS BOARD OF PROFESSIONAL ENGINEERS
CERTIFICATE OF REGISTRATION # F-11852

PRODUCT: SINGLE OPAQUE FIBERGLASS DOOR
"IMPACT" INSWING / OUTSWING
PART OR ASSEMBLY:

TYPICAL ELEVATION, DESIGN PRESSURES & GENERAL NOTES

NO.	DATE	BY	REVISIONS

DATE: 7/16/12
SCALE: N.T.S.
DWG. BY: JK
CHK. BY: LFS
DRAWING NO.: TX-4177
SHEET 1 OF 6

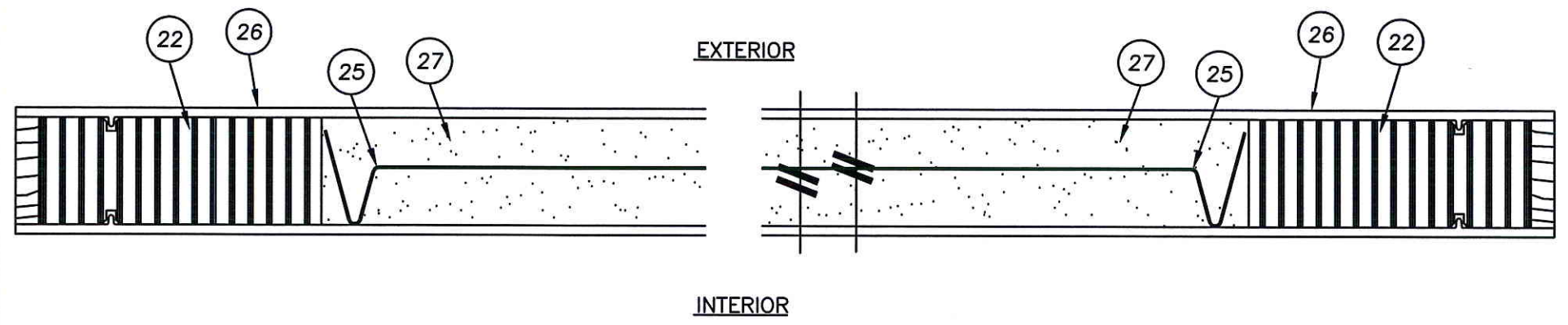

2 HORIZONTAL CROSS SECTION
2 CLASSIC CRAFT RUSTIC

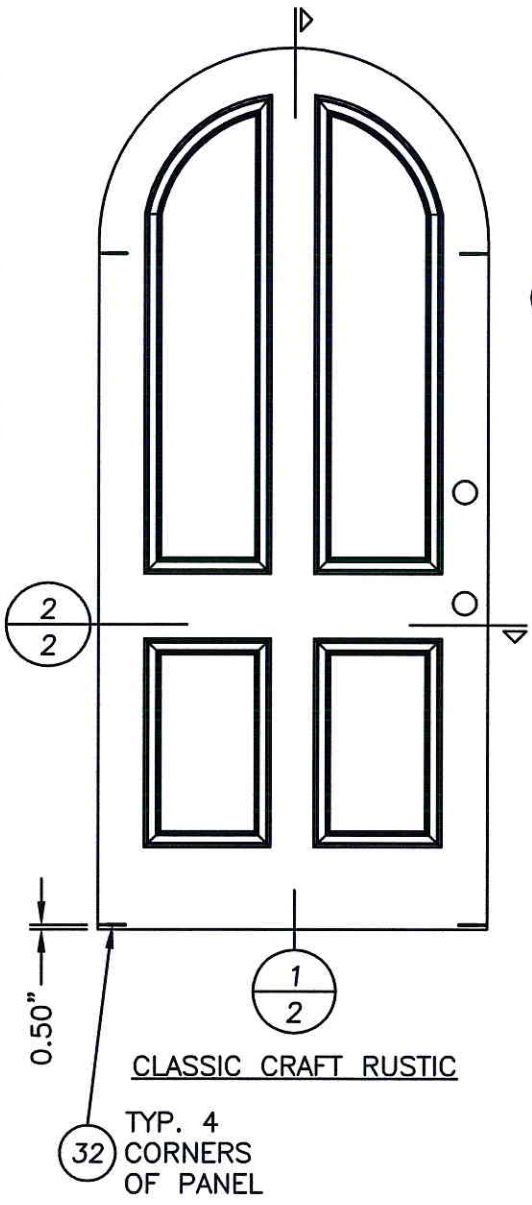

1 VERTICAL CROSS SECTION
2 CLASSIC CRAFT RUSTIC

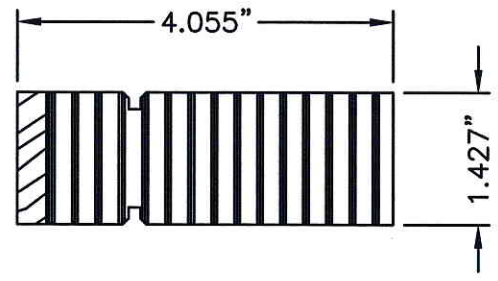
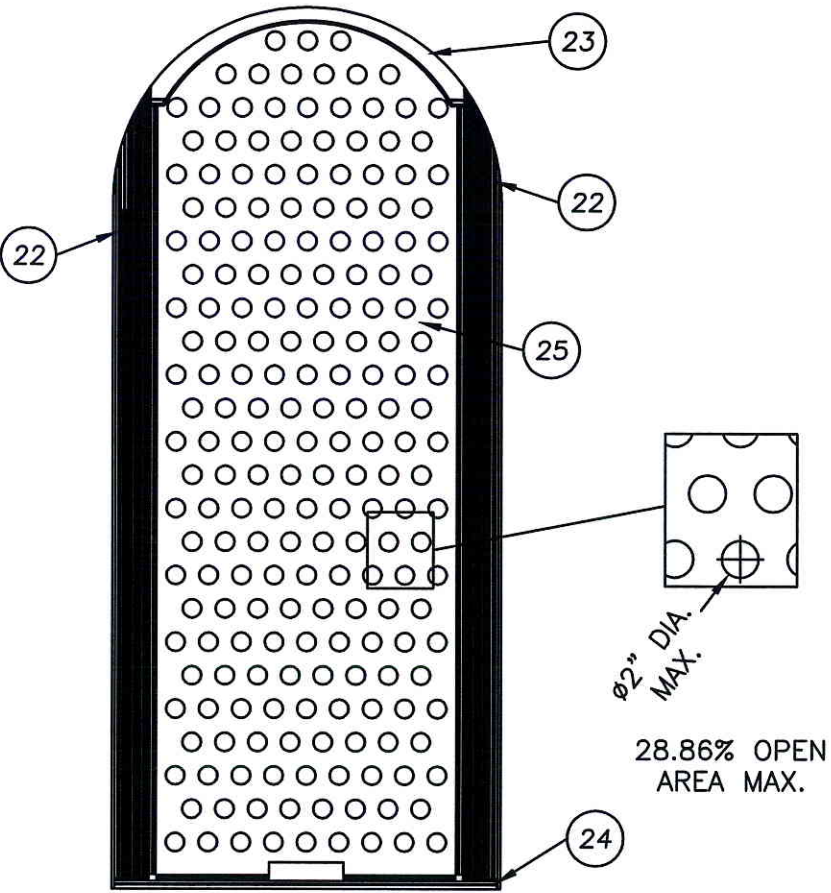

22 LOCK & HINGE STILE
CLASSIC CRAFT RUSTIC

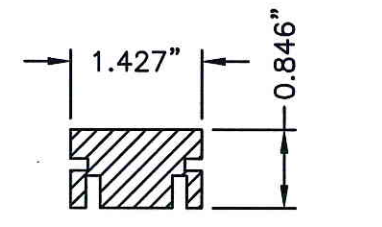

24 BOTTOM RAIL
CLASSIC CRAFT RUSTIC

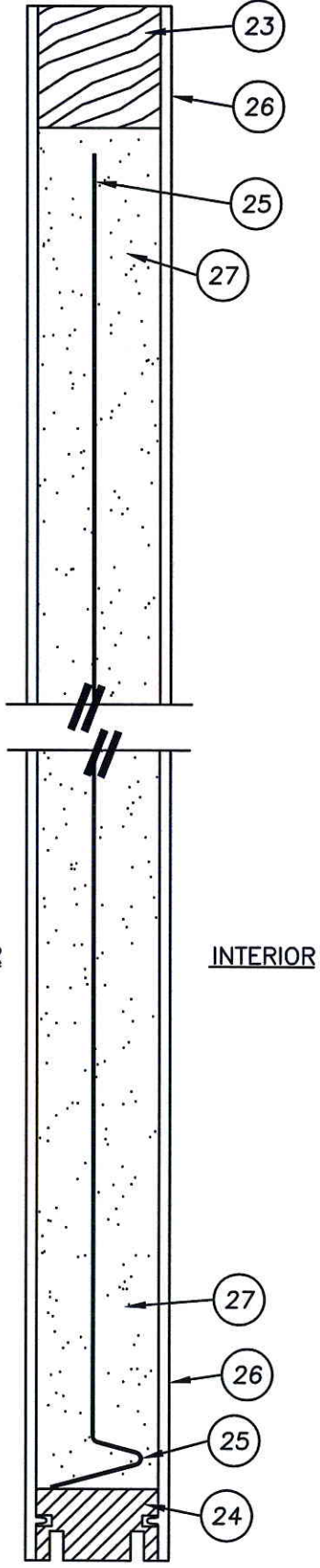

23 TOP RAIL
CLASSIC CRAFT RUSTIC

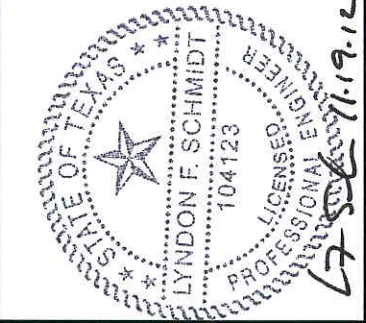
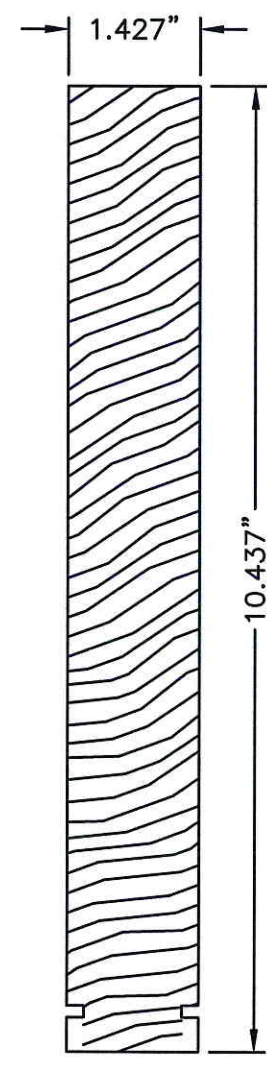

Documents Prepared By: Lyndon F. Schmidt, P.E.
TEXAS P.E. #104123
RW BUILDING CONSULTANTS, INC.
P.O. Box 230 Valrico FL 33595
Phone No.: 813.659.9197
TEXAS BOARD OF PROFESSIONAL ENGINEERS
CERTIFICATE OF REGISTRATION # F-11852

PRODUCT: SINGLE OPAQUE
FIBERGLASS DOOR
"IMPACT" INSWING / OUTSWING
PART OR ASSEMBLY:
DOOR PANEL DETAILS
(CLASSIC CRAFT RUSTIC)

NO.	DATE	BY	REVISIONS

DATE: 7/16/12
SCALE: N.T.S.
DWG. BY: JK
CHK. BY: LFS
DRAWING NO.: TX-4177
SHEET 2 OF 6

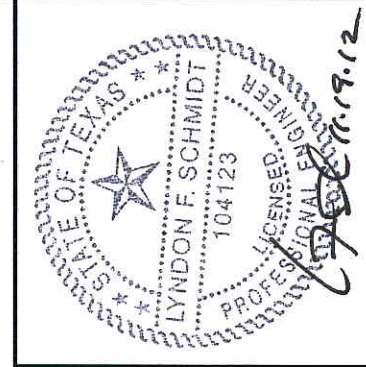
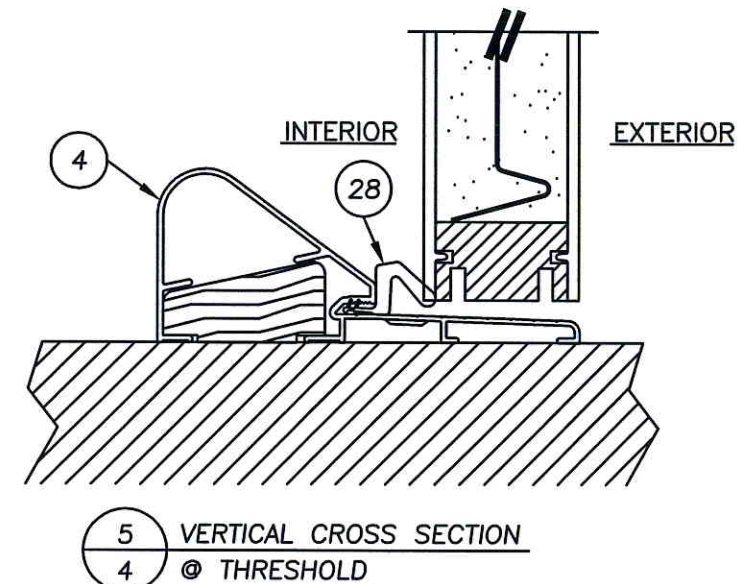
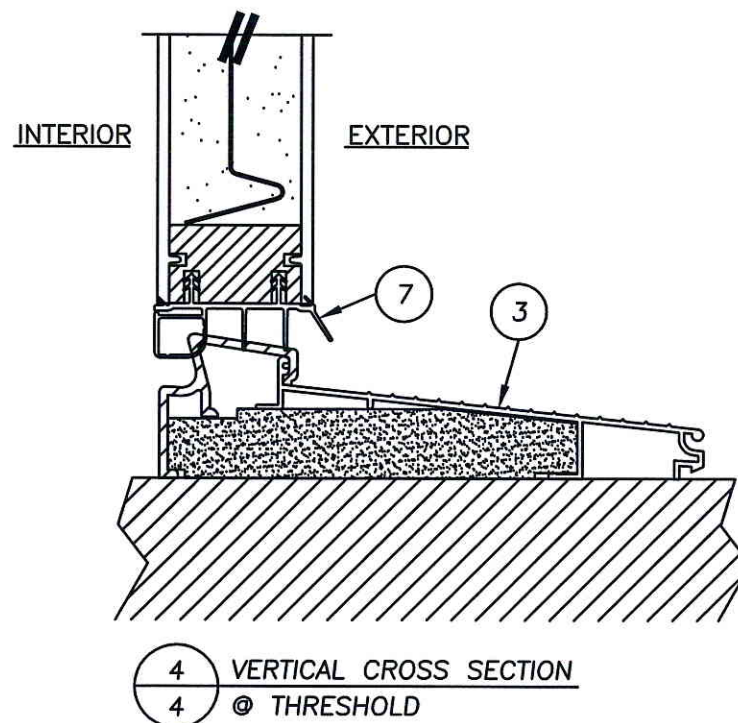
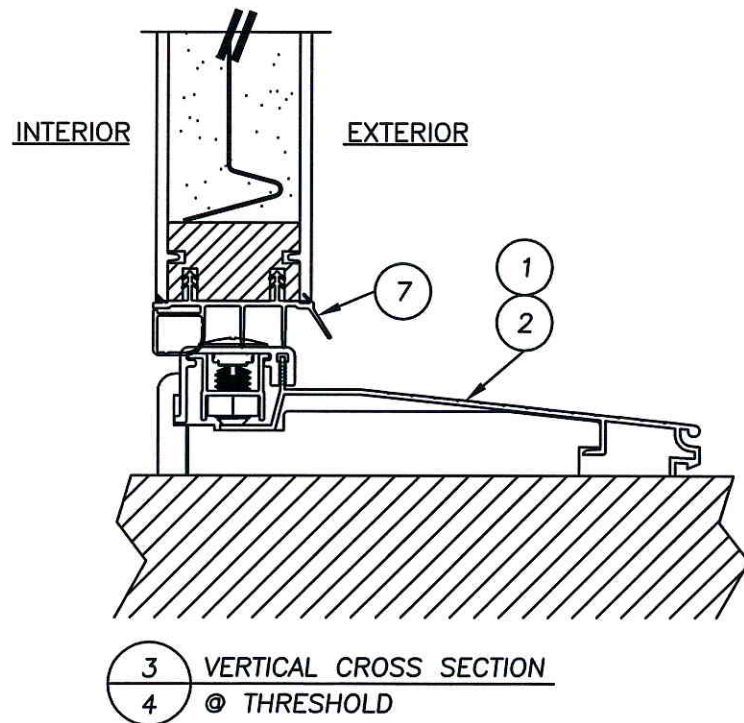
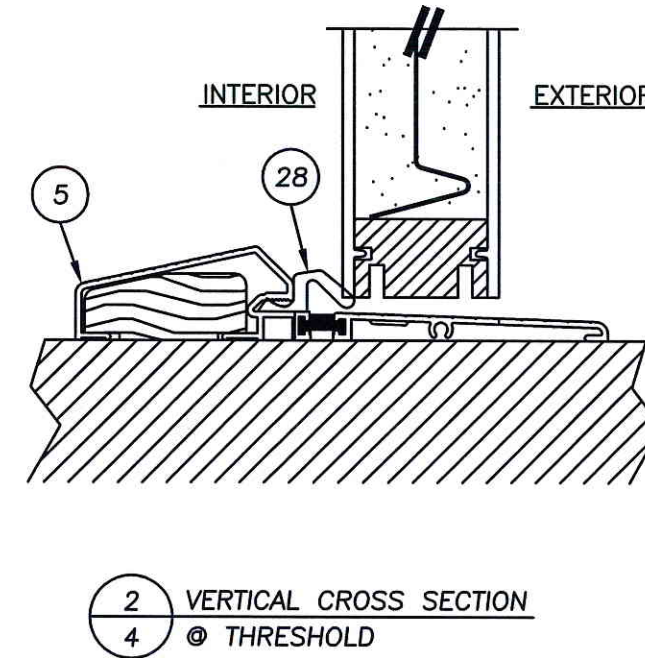
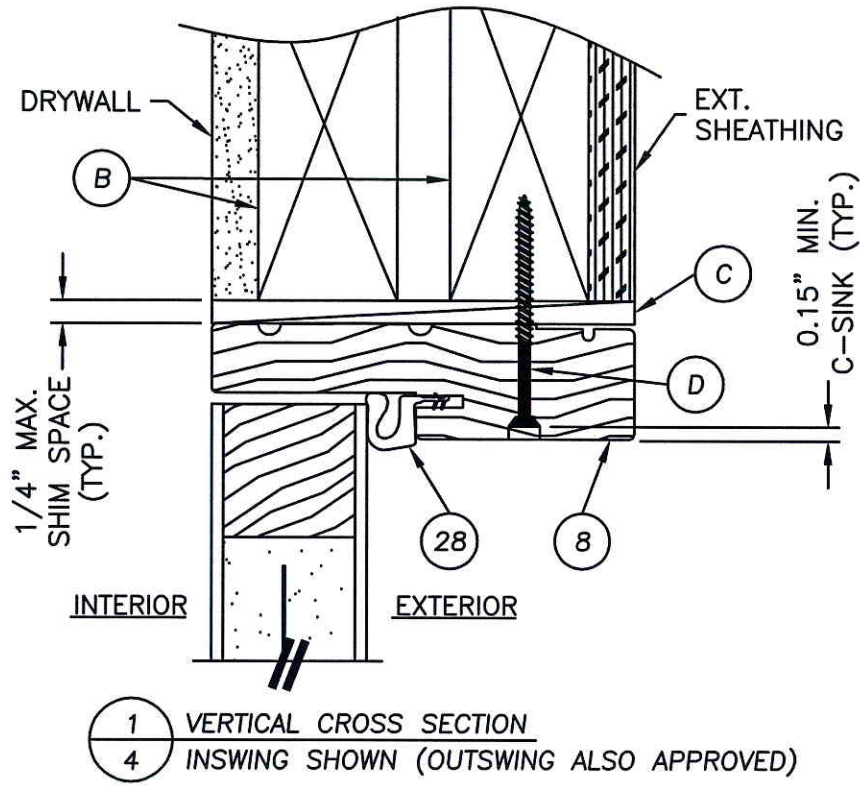

Documents Prepared By: Lyndon F. Schmidt, P.E.
TEXAS P.E. #104123

RW BUILDING CONSULTANTS, INC.
P.O. Box 230 Valrico FL 33595
Phone No.: 813.659.9197

TEXAS BOARD OF PROFESSIONAL ENGINEERS
CERTIFICATE OF REGISTRATION # F-11852

PRODUCT: SINGLE OPAQUE
FIBERGLASS DOOR
"IMPACT" INSWING / OUTSWING
PART OR ASSEMBLY:

VERTICAL CROSS SECTIONS

NO.	DATE	REVISIONS	BY

DATE: 7/16/12
SCALE: N.T.S.
DWG. BY: JK
CHK. BY: LFS
DRAWING NO.: TX-4177
SHEET 4 OF 6

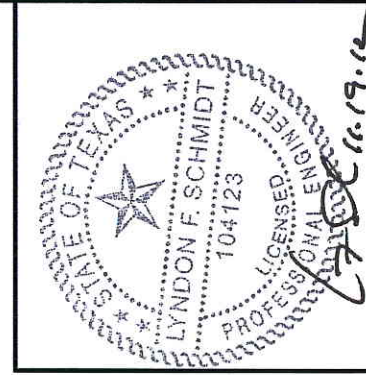
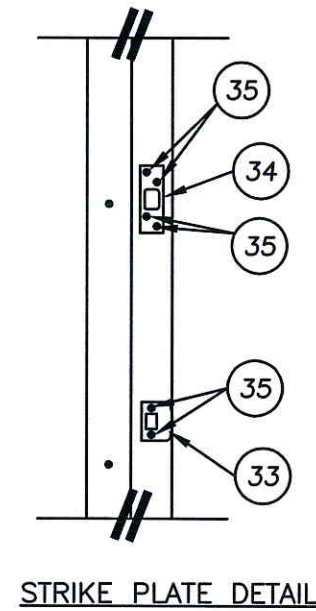
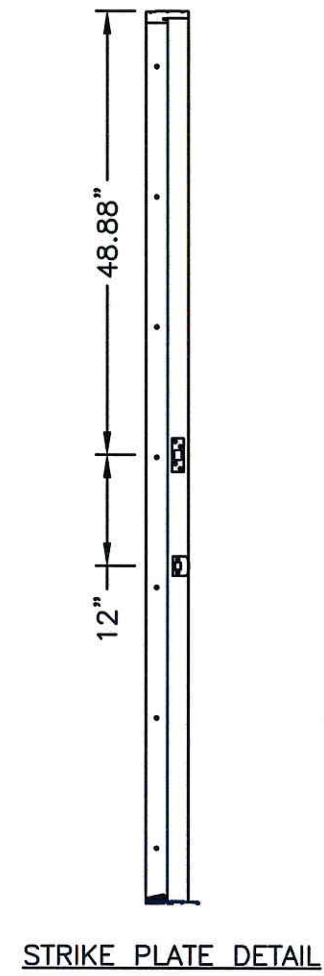
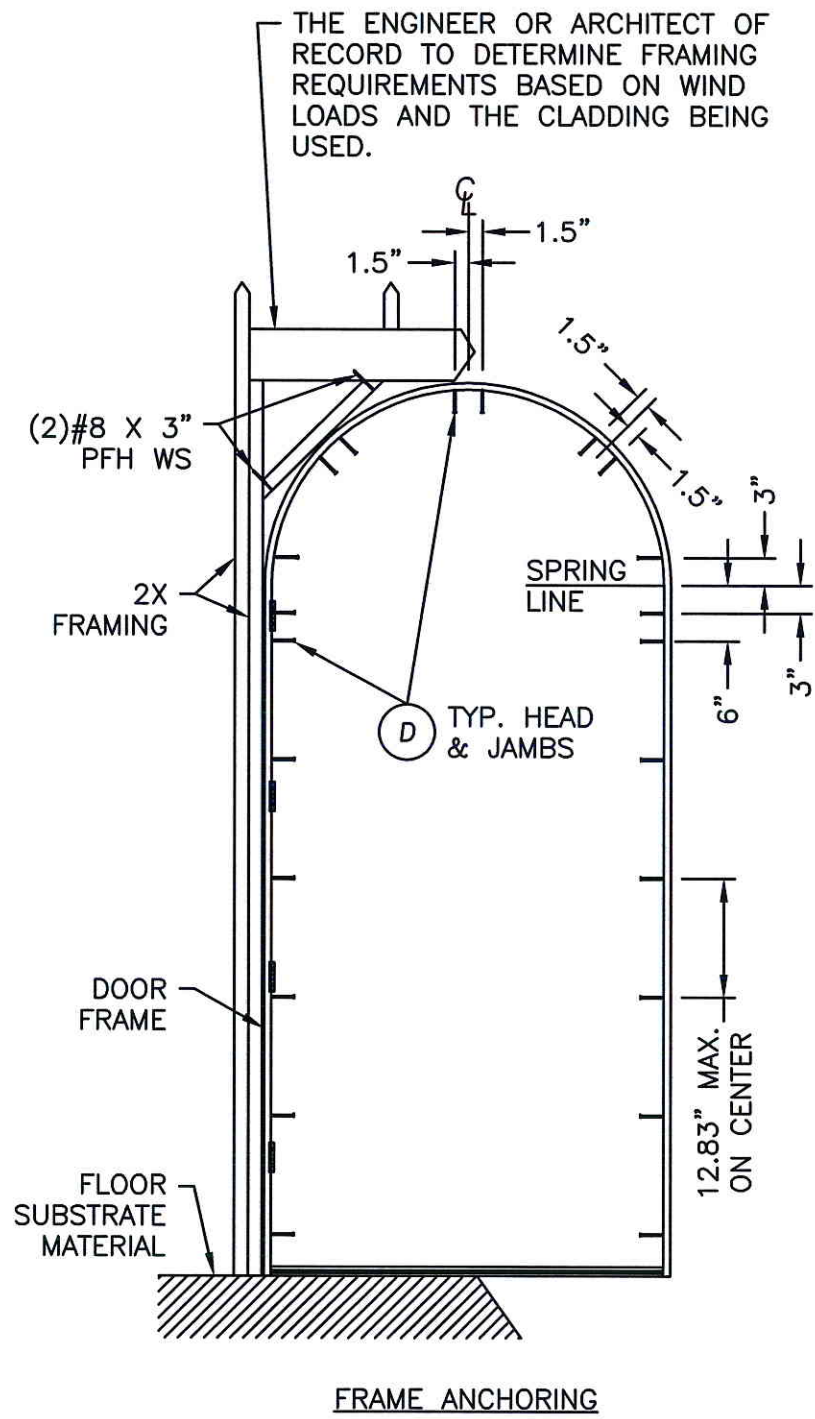
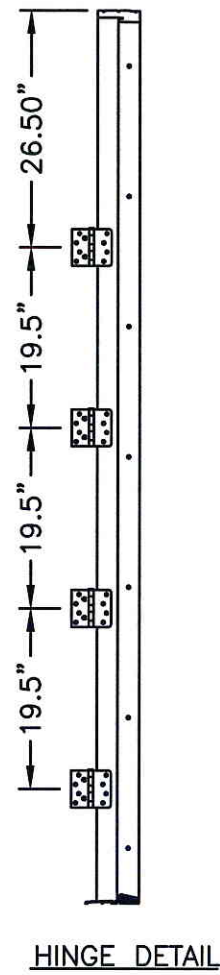
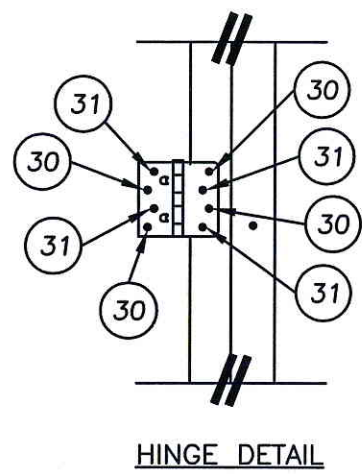

Documents Prepared By: Lyndon F. Schmidt, P.E.
TEXAS P.E. #104123

RW BUILDING CONSULTANTS, INC.
P.O. Box 230 Valrico FL 33595
Phone No.: 813.659.9197

TEXAS BOARD OF PROFESSIONAL ENGINEERS
CERTIFICATE OF REGISTRATION # F-11852

PRODUCT: SINGLE OPAQUE
FIBERGLASS DOOR
"IMPACT" INSWING / OUTSWING
PART OR ASSEMBLY: FRAME ANCHORING

NO.	DATE	BY	REVISIONS

DATE: 7/16/12
SCALE: N.T.S.
DWG. BY: JK
CHK. BY: LFS
DRAWING NO.: TX-4177
SHEET 5 OF 6

BILL OF MATERIALS		
ITEM	DESCRIPTION	MATERIAL
B	2X FRAMING (G >= 0.42)	WOOD
C	1/4" MAX. SHIM SPACE	WOOD
D	#10 X 2-1/2" PFH WOOD SCREW	STEEL
G	KWIKSET 200 SERIES PASSAGE LOCK	STEEL
H	KWIKSET 600 SERIES DEADBOLT	STEEL
1	INSWING ADJUSTABLE THRESHOLD (IS300AJ)	ALUM./WOOD
2	INSWING THRESHOLD (IS300HP5)	ALUM./COMP.
3	INSWING SELF ADJUST THERMAL BREAK THRESHOLD (ISP30M)	ALUM./COMP.
4	OUTSWING COASTAL THRESHOLD	ALUM./WOOD
5	OUTSWING STANDARD THRESHOLD	ALUM./WOOD
7	DOOR BOTTOM SWEEP	VINYL
8	JAMB (OAK)	WOOD
22	LOCK & HINGE STILE (CLASSIC CRAFT RUSTIC)	WOOD/LVL
23	TOP RAIL (CLASSIC CRAFT RUSTIC)	WOOD
24	BOTTOM RAIL (CLASSIC CRAFT RUSTIC)	PVC
25	PANEL REINFORCEMENT 0.023" THK. (CLASSIC CRAFT RUSTIC)	STEEL
26	DOOR SKIN 0.125" THK. (CC RUSTIC) Fy = 6,000 PSI MIN.	FIBERGLASS
27	FOAM CORE	POLYURETHANE
28	WEATHERSTRIP	FOAM
29	HINGE	STEEL
30	#10 X 2-1/2" PFH SCREW	STEEL
31	#10 X 3/4" PFH SCREW	STEEL
32	#9 X 3" PFH WOOD SCREW	STEEL
33	LATCH STRIKE PLATE	STEEL
34	SECURITY STRIKE PLATE (SINGLE DOOR ONLY)	STEEL
35	#8 X 3" PFH SCREW	STEEL
52	DOOR BOTTOM SWEEP	VINYL

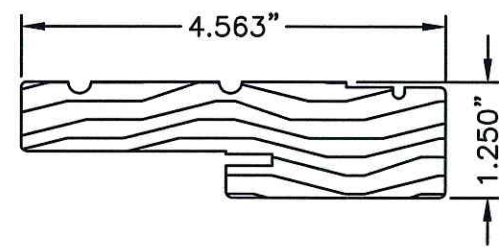

8 JAMB

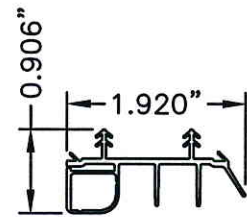

7 SWEEP

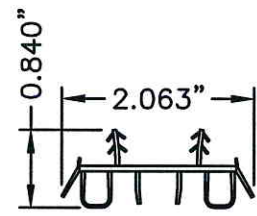

52 SWEEP

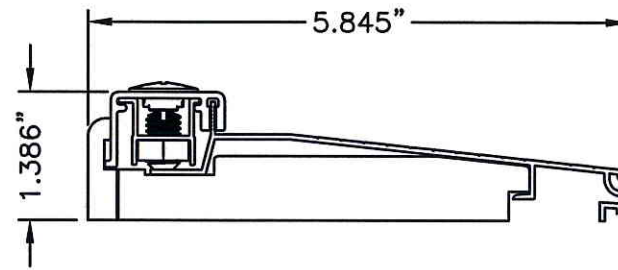

2 THRESHOLD
INSWING ADJUSTABLE

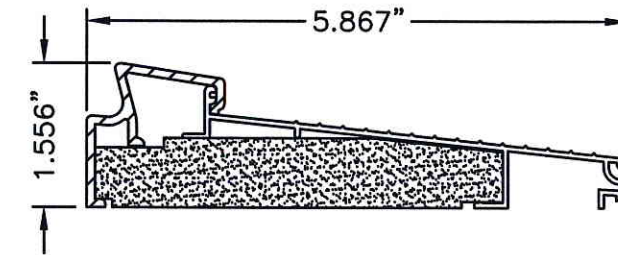

3 THRESHOLD
INSWING SELF-ADJUST

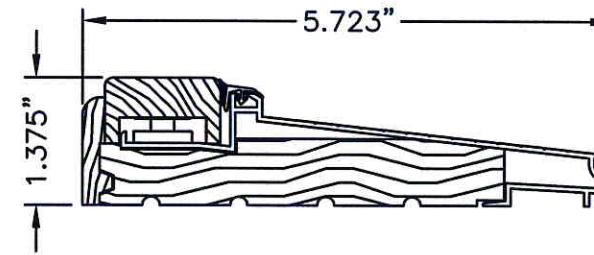

1 THRESHOLD
INSWING ADJUSTABLE

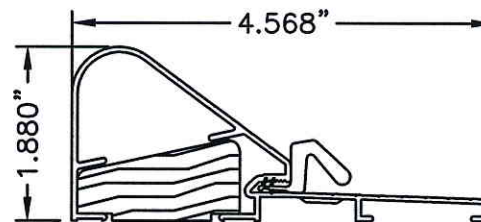

4 THRESHOLD
OUTSWING COASTAL

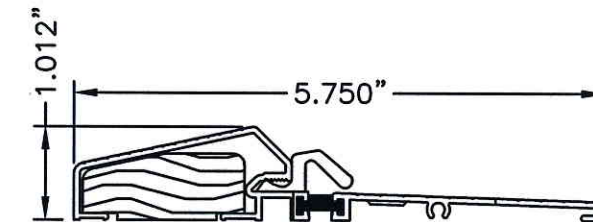

5 THRESHOLD
OUTSWING STANDARD

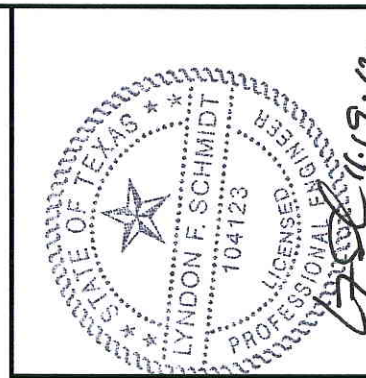

Documents Prepared By: Lyndon F. Schmidt, P.E.
TEXAS P.E. #104123

RW BUILDING CONSULTANTS, INC.
P.O. Box 230 Vairico FL 33595
Phone No.: 813.659.9197

TEXAS BOARD OF PROFESSIONAL ENGINEERS
CERTIFICATE OF REGISTRATION # F-11852

PRODUCT: SINGLE OPAQUE FIBERGLASS DOOR "IMPACT" INSWING / OUTSWING PART OR ASSEMBLY:

BILL OF MATERIALS & COMPONENTS

NO.	DATE	BY	REVISIONS

DATE: 7/16/12
SCALE: N.T.S.
DWG. BY: JK
CHK. BY: LFS
DRAWING NO.: TX-4177
SHEET 6 OF 6