

# THERMA TRU®

118 INDUSTRIAL DR., EDGERTON, OH 43517  
TEL. (419)298-1740

## "SMOOTH STAR", "FIBER CLASSIC", "CLASSIC CRAFT" & "CLASSIC CRAFT RUSTIC" GLAZED FIBERGLASS DOUBLE DOOR IN SWING / OUT SWING "IMPACT"

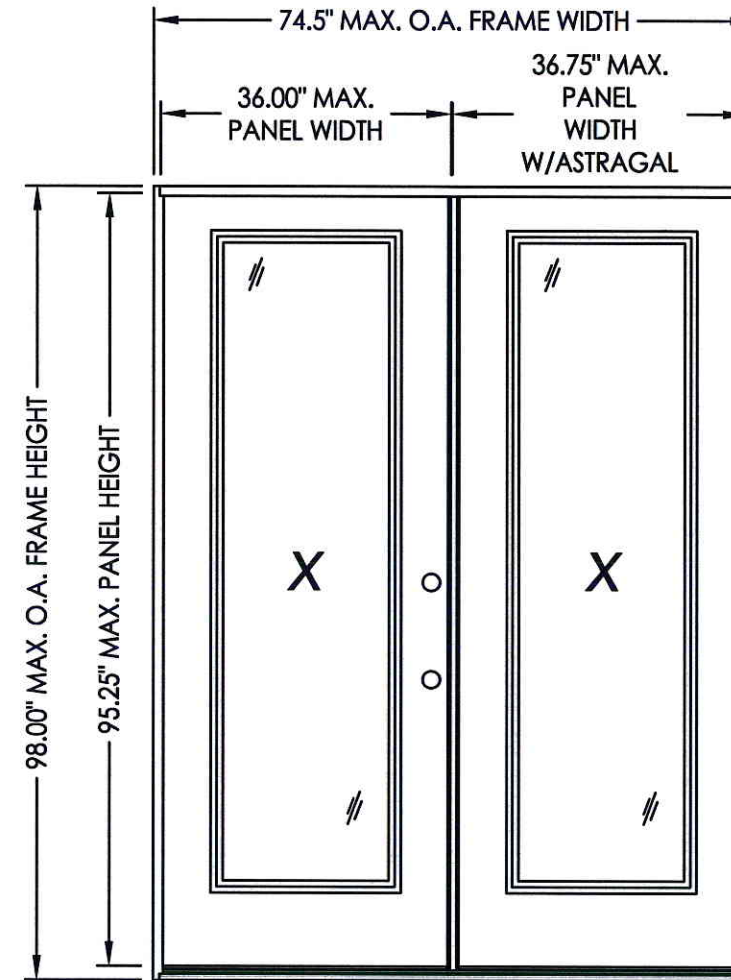

"SMOOTH STAR", "FIBER CLASSIC"  
"CLASSIC CRAFT" & "CLASSIC CRAFT RUSTIC"

SWING	OVERALL FRAME DIMENSION	OVERALL D.L.O. DOOR / SIDELITE DIMENSION	DESIGN PRESSURE (PSF)	
			POSITIVE	NEGATIVE
IN SWING	74.5" X 98.00"	21.00" X 78.75"	+50.0	-50.0
OUT SWING	74.5" X 96.75"	21.00" X 78.75"	+50.0	-50.0

### EVALUATED FOR USE IN THE STATE OF TEXAS

The Fiberglass Glazed Door described herein complies with the 2006 International Residential Code (IRC), Sections R301 & R613 and the 2006 International Building Code (IBC), Sections 1405.12, 1609, 1714.5, 2403 and 2404 (including Texas revisions) subject to the following conditions:

1. Anchors shall be as listed and spaced as shown in the details. Anchor embedment to base material shall be beyond wall dressing or stucco.
2. This system has been tested and evaluated as a large missile impact protective system for installation in the Seaward, Inland I and Inland II areas. This product meets missile level "D" as defined in ASTM E 1996.
3. Allowable design pressure requirements must be equal to or less than the design pressure rating shown in the design pressure chart, sheet 1 of this drawing.
4. Conditions not covered by this drawing are subject to further engineering analysis.

TABLE OF CONTENTS	
SHEET #	DESCRIPTION
1	TYPICAL ELEVATION, DESIGN PRESSURES & GENERAL NOTES
2	"SMOOTH STAR" DOOR PANEL DETAILS
3	"CLASSIC CRAFT" & "CLASSIC CRAFT RUSTIC" DOOR PANEL DETAILS
4	"FIBER CLASSIC" DOOR PANEL DETAILS
5	HORIZONTAL CROSS SECTIONS
6	VERTICAL CROSS SECTIONS
7	FRAME ANCHORING
8	COMPONENTS
9	BILL OF MATERIALS & COMPONENTS

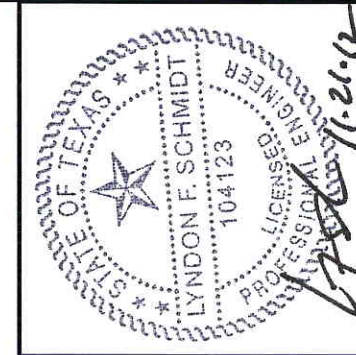

Documents Prepared By: Lyndon F. Schmidt, P.E.  
TEXAS P.E. #104123

**RW** BUILDING CONSULTANTS, INC.  
P.O. Box 230 Vairico FL 33595  
Phone No.: 813.659.9197  
TEXAS BOARD OF PROFESSIONAL ENGINEERS  
CERTIFICATE OF REGISTRATION # F-11852

PRODUCT: THERMA-TRU  
GLAZED FIBERGLASS DOUBLE DOOR  
IN/OUTSWING "IMPACT"  
PART OR ASSEMBLY:  
TYPICAL ELEVATION, DESIGN  
PRESSURES & GENERAL NOTES

NO.	DATE	BY	REVISIONS

DATE: 7/17/12  
SCALE: N.T.S.  
DWG. BY: JK  
CHK. BY: LFS  
DRAWING NO.: TX-4198  
SHEET 1 OF 9

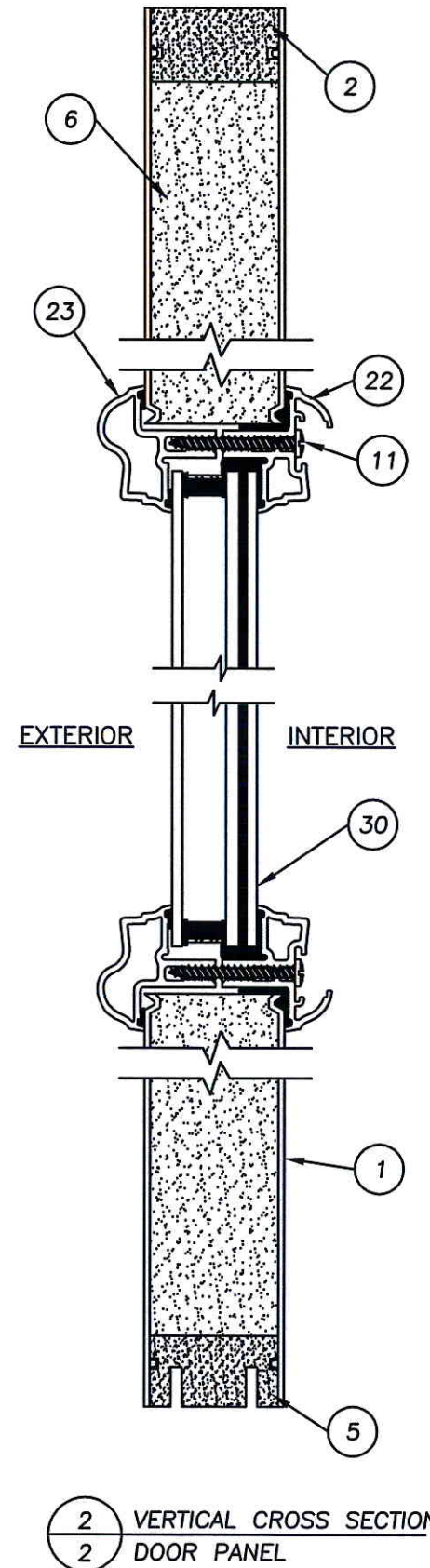
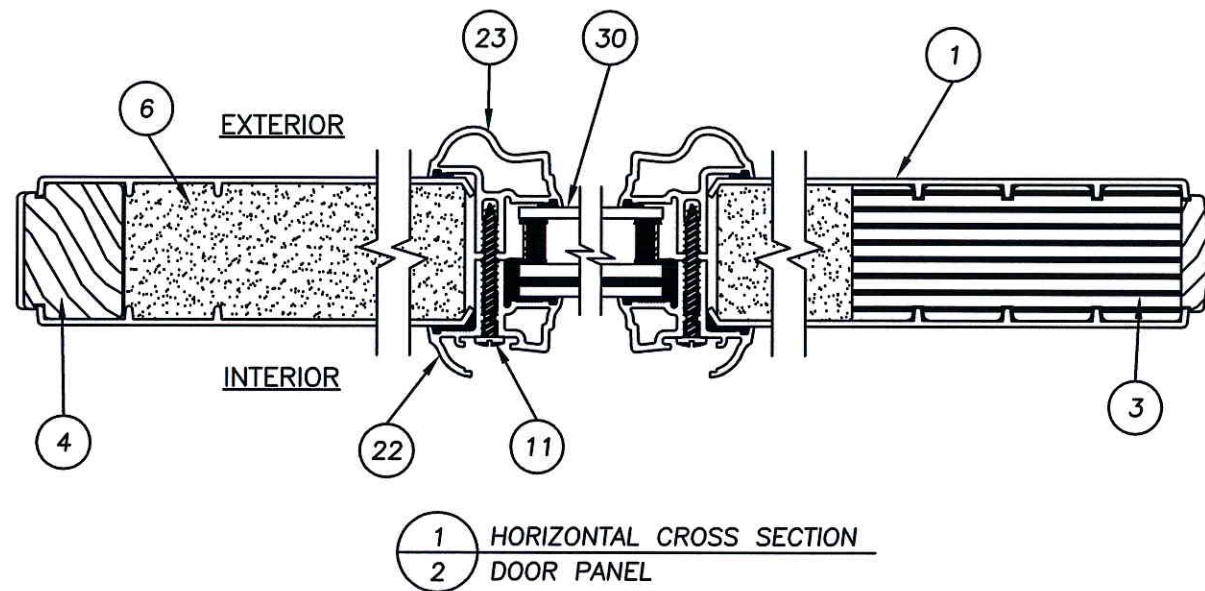
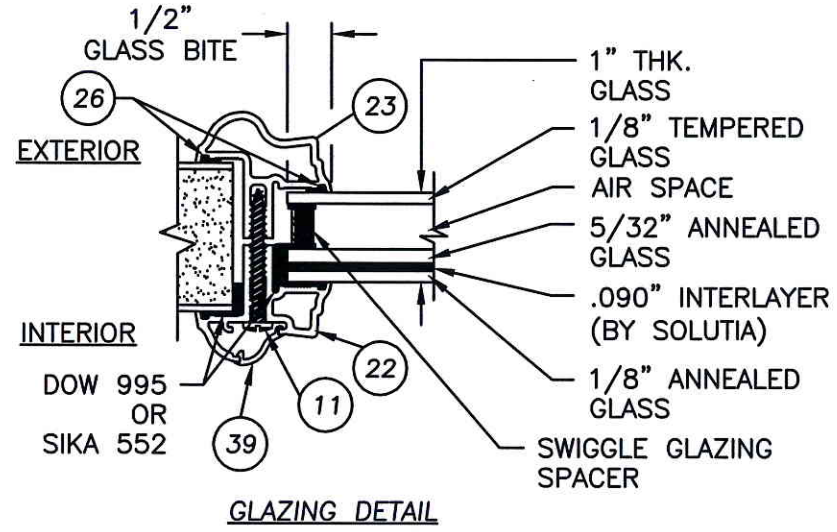
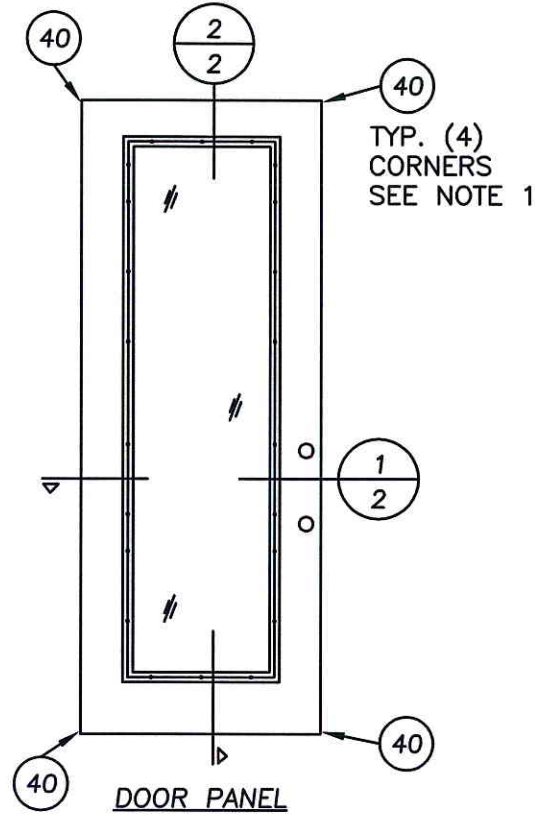

Documents Prepared By: Lyndon F. Schmidt, P.E.  
TEXAS P.E. #104123

**RW** BUILDING CONSULTANTS, INC.  
P.O. Box 230 Valrico FL 33595  
Phone No.: 813.659.9197

TEXAS BOARD OF PROFESSIONAL ENGINEERS  
CERTIFICATE OF REGISTRATION # F-11852

PRODUCT:	THERMA-TRU GLAZED FIBERGLASS DOUBLE DOOR IN/OUTSWING "IMPACT"	
PART OR ASSEMBLY:	"SMOOTH STAR" DOOR PANEL DETAILS	
NO.	DATE	BY
REVISIONS		
DATE:	7/17/12	
SCALE:	N.T.S.	
DWG. BY:	JK	
CHK. BY:	LFS	
DRAWING NO.:	TX-4198	
SHEET	2	OF 9

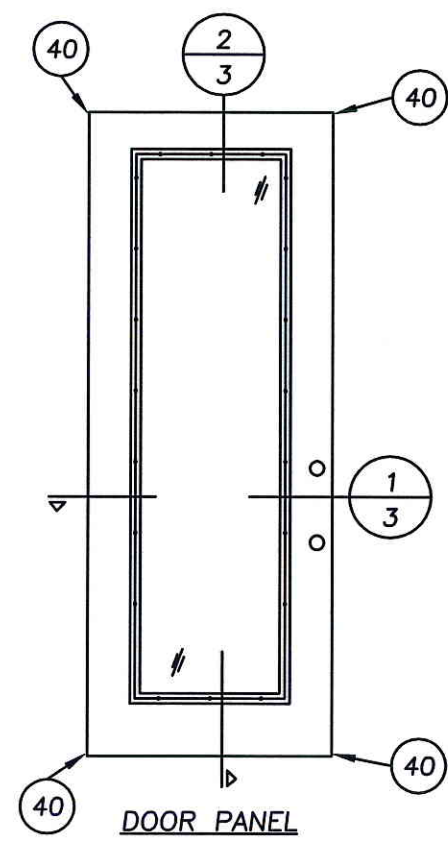

DOOR PANEL

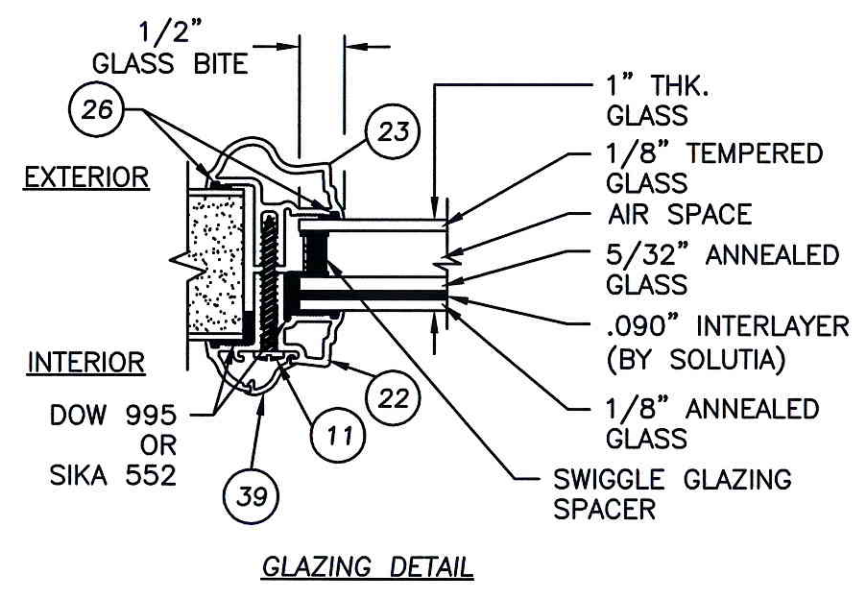

GLAZING DETAIL

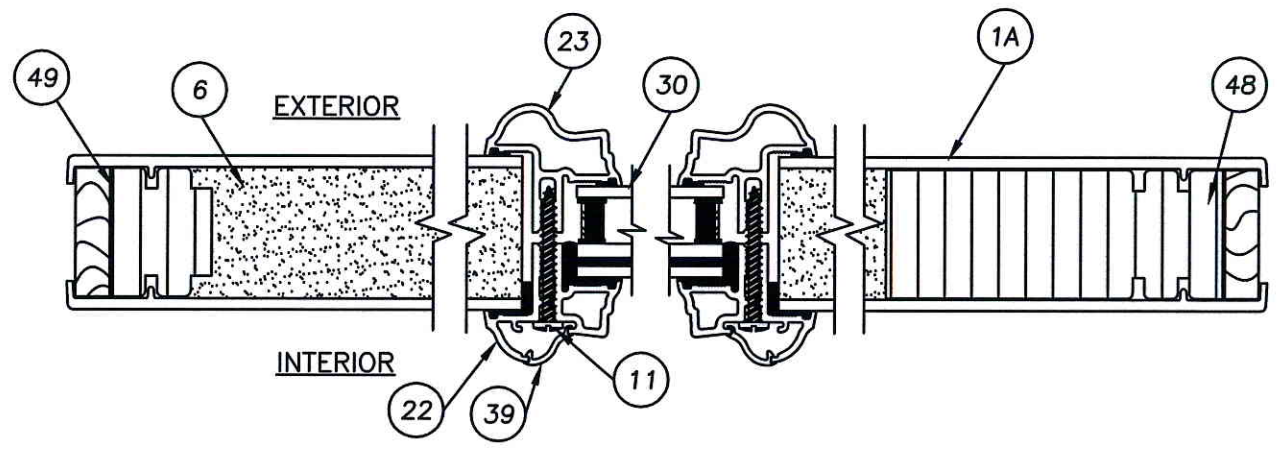

1 HORIZONTAL CROSS SECTION  
3 DOOR PANEL

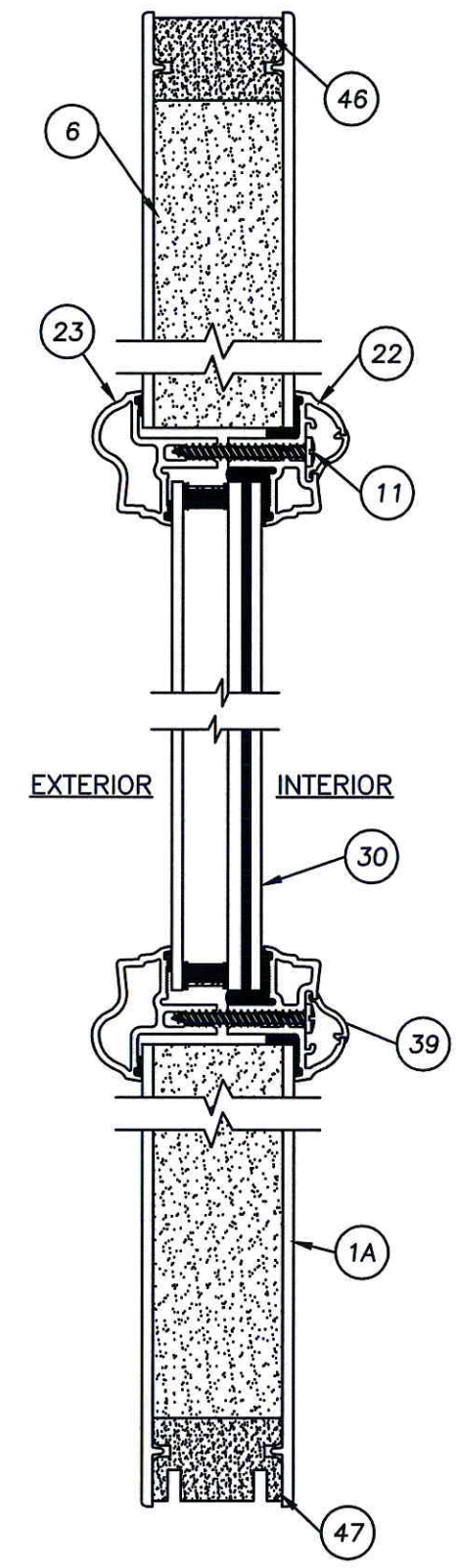

2 VERTICAL CROSS SECTION  
3 DOOR PANEL

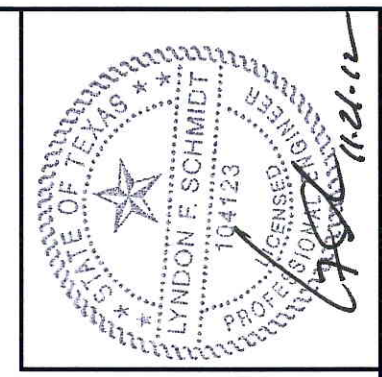

Documents Prepared By: Lyndon F. Schmidt, P.E.  
TEXAS P.E. #104123

**RW** BUILDING CONSULTANTS, INC.  
P.O. Box 230 Vairico FL 33595  
Phone No.: 813.659.9197

TEXAS BOARD OF PROFESSIONAL ENGINEERS  
CERTIFICATE OF REGISTRATION # F-11852

PRODUCT: THERMA-TRU  
GLAZED FIBERGLASS DOUBLE DOOR  
IN/OUTSWING "IMPACT"

PART OR ASSEMBLY:  
"CLASSIC CRAFT" & "CC RUSTIC"  
DOOR PANEL DETAILS

NO.	DATE	BY	REVISIONS

DATE: 7/17/12  
SCALE: N.T.S.  
DWG. BY: JK  
CHK. BY: LFS  
DRAWING NO.: TX-4198  
SHEET 3 OF 9

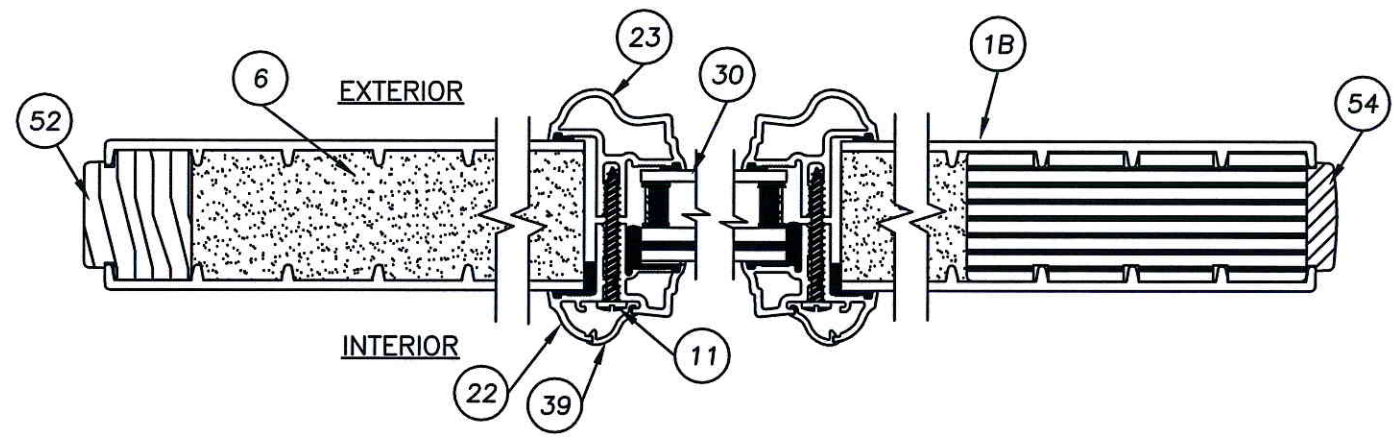
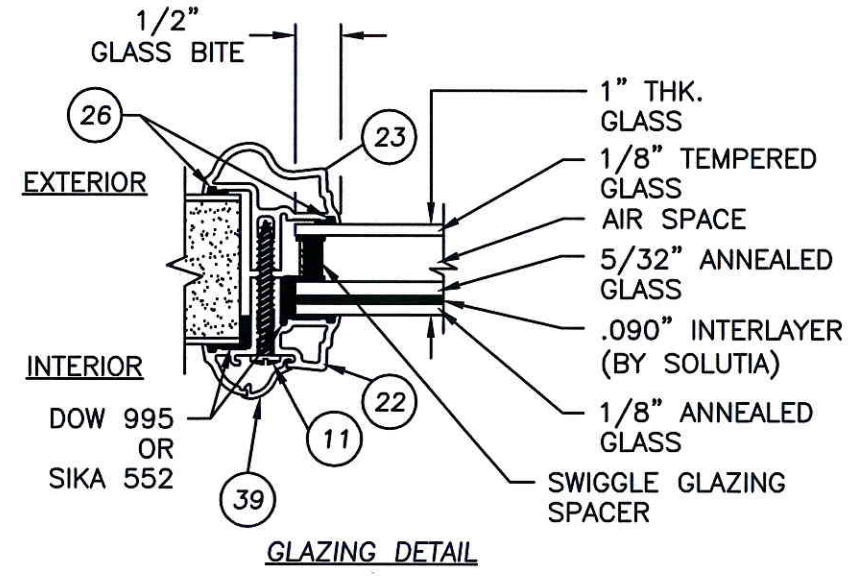
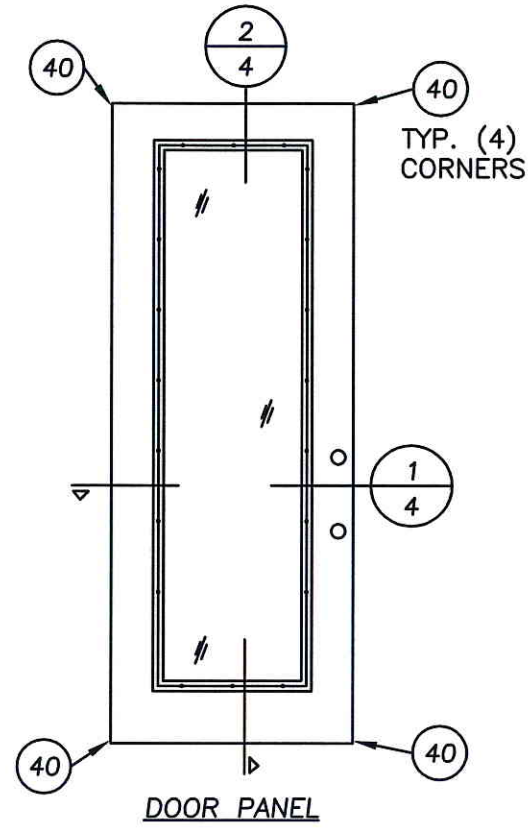

1 HORIZONTAL CROSS SECTION  
4 DOOR PANEL

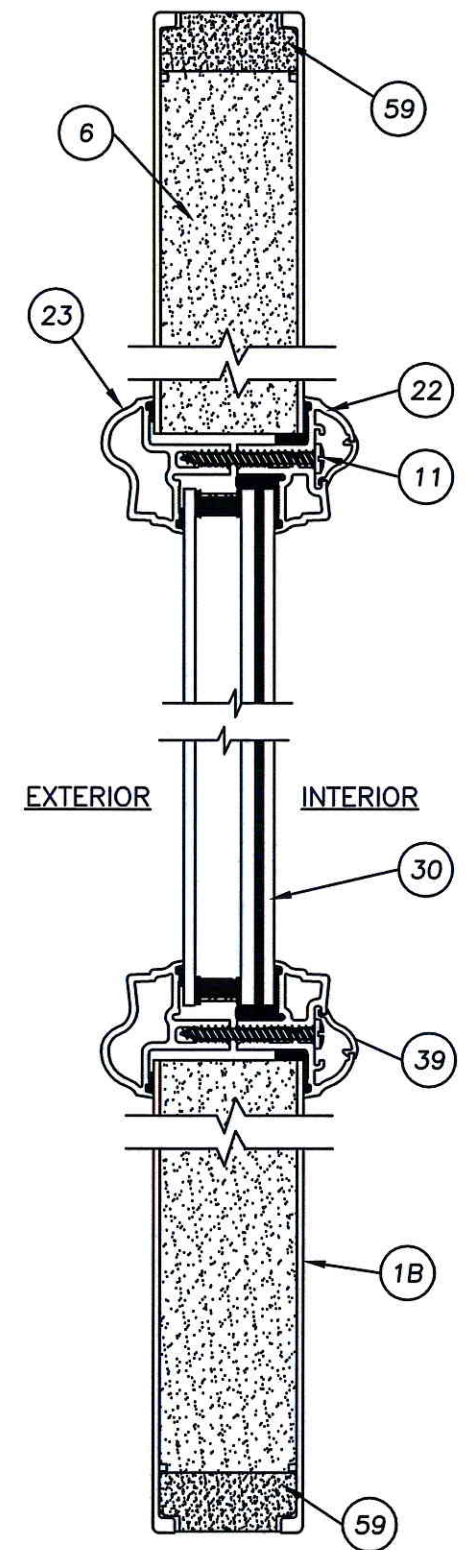

2 VERTICAL CROSS SECTION  
4 DOOR PANEL

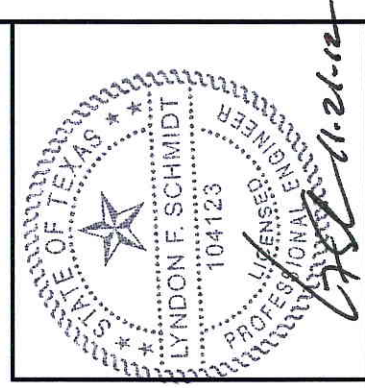

Documents Prepared By: Lyndon F. Schmidt, P.E.  
TEXAS P.E. #104123

**RW** BUILDING CONSULTANTS, INC.  
P.O. Box 230 Valrico FL 33595  
Phone No.: 813.659.9197

TEXAS BOARD OF PROFESSIONAL ENGINEERS  
CERTIFICATE OF REGISTRATION # F-11852

PRODUCT: THERMA-TRU  
GLAZED FIBERGLASS DOUBLE DOOR  
IN/OUTSWING "IMPACT"

PART OR ASSEMBLY:  
"FIBER CLASSIC"  
DOOR PANEL DETAILS

NO.	DATE	REVISIONS	BY

DATE: 7/17/12  
SCALE: N.T.S.  
DWG. BY: JK  
CHK. BY: LFS  
DRAWING NO.: TX-4198  
SHEET 4 OF 9

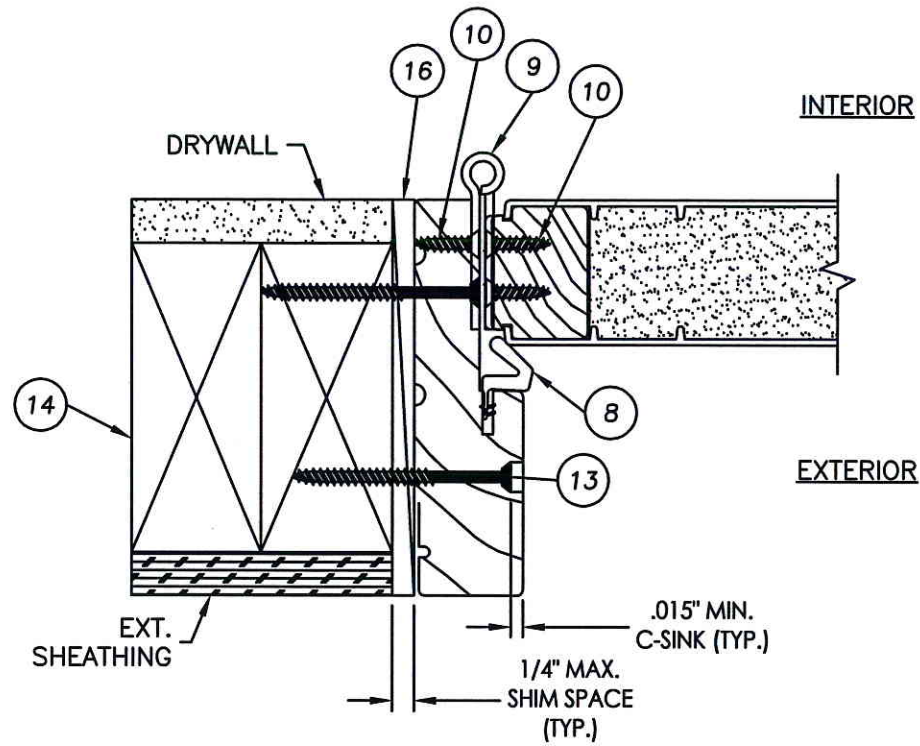
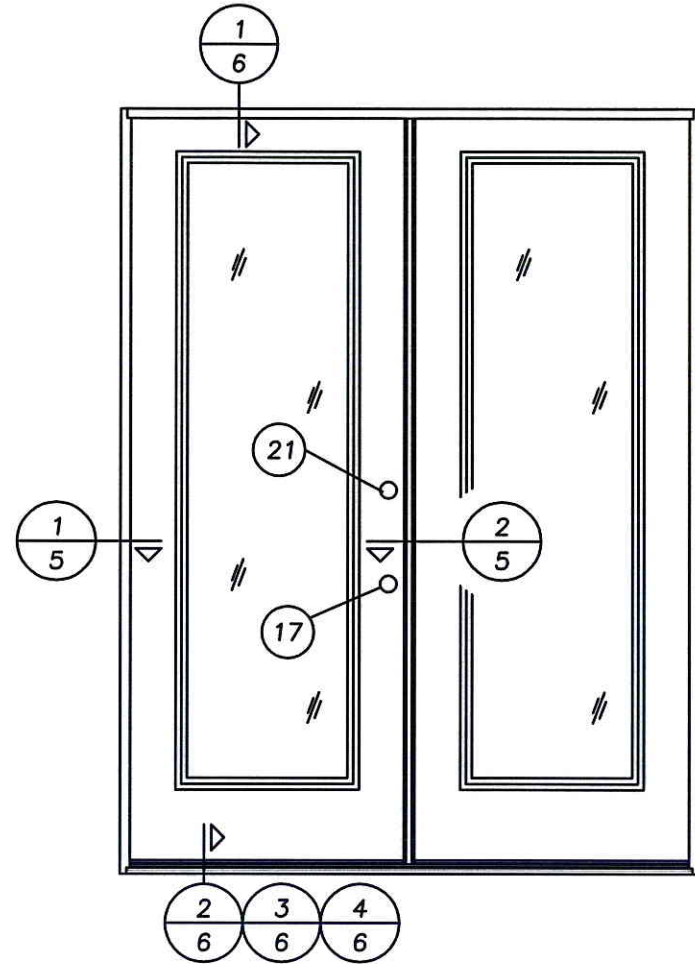

**1** **HORIZONTAL CROSS SECTION**  
**5** INSWING SHOWN (OUTSWING ALSO APPROVED)  
 ("Smooth Star Series" shown)

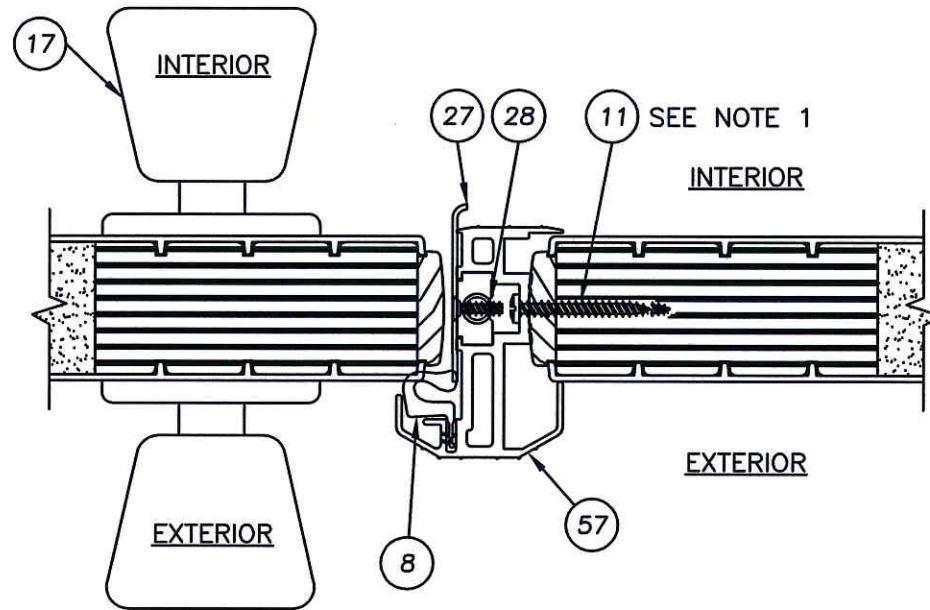

**2** **HORIZONTAL CROSS SECTION**  
**5** INSWING SHOWN (OUTSWING ALSO APPROVED)  
 ("Smooth Star Series" shown)

**NOTE:**  
 1. ASTRAGAL RETAINING SCREWS LOCATED @  
 3/4", 2", 3-1/4", 4-1/2", 18-7/8",  
 37-1/4", 57-7/8", 76-3/8", 90-3/4",  
 92", 93" & 94-1/2" FROM TOP OF  
 ASTRAGAL (12 TOTAL).

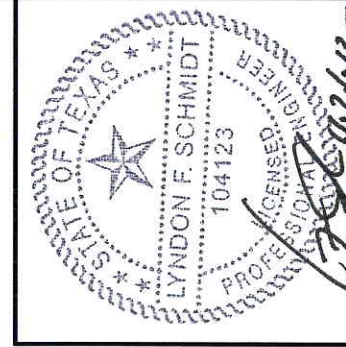

Documents Prepared By: Lyndon F. Schmidt, P.E.  
 TEXAS P.E. #104123

**RW** BUILDING CONSULTANTS, INC.  
 P.O. Box 230 Valrico FL 33596  
 Phone No.: 813.659.9197

TEXAS BOARD OF PROFESSIONAL ENGINEERS  
 CERTIFICATE OF REGISTRATION # F-11852

PRODUCT:	THERMA-TRU GLAZED FIBERGLASS DOUBLE DOOR IN/OUTSWING IMPACT												
PART OR ASSEMBLY:	HORIZONTAL CROSS SECTIONS												
DATE:	7/17/12												
SCALE:	N.T.S.												
DWG. BY:	JK												
CHK. BY:	LFS												
DRAWING NO.:	TX-4198												
SHEET	5 of 9												
<table border="1"> <thead> <tr> <th>NO.</th> <th>DATE</th> <th>BY</th> <th>REVISIONS</th> </tr> </thead> <tbody> <tr> <td> </td> <td> </td> <td> </td> <td> </td> </tr> <tr> <td> </td> <td> </td> <td> </td> <td> </td> </tr> </tbody> </table>		NO.	DATE	BY	REVISIONS								
NO.	DATE	BY	REVISIONS										

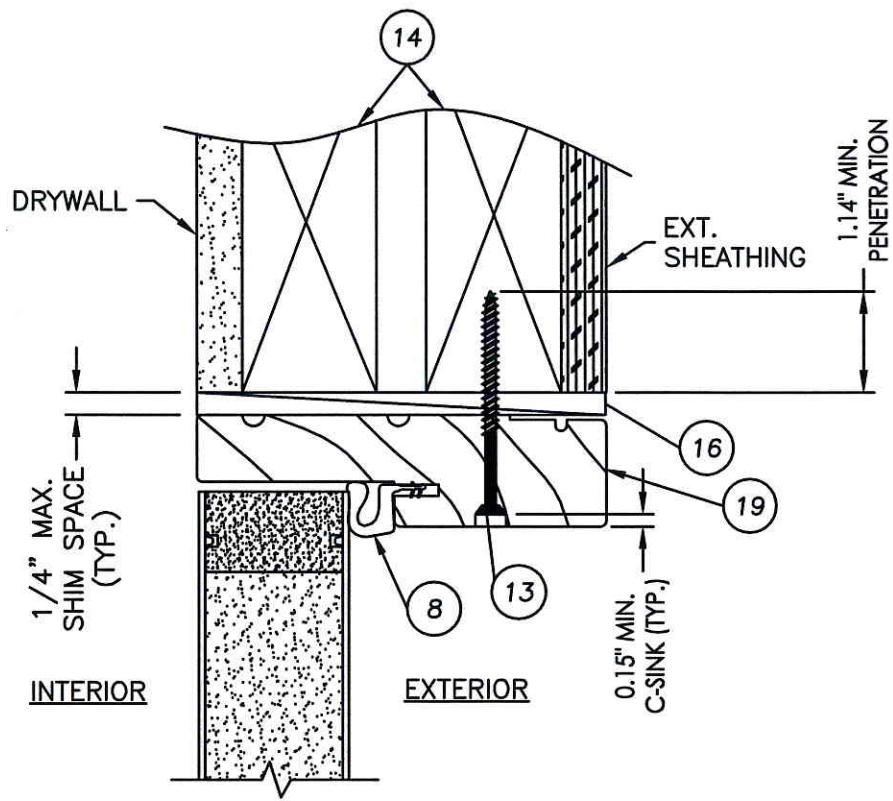

1 VERTICAL CROSS SECTION  
6 INSWING SHOWN (OUTSWING ALSO APPROVED)  
("SMOOTH STAR SERIES" SHOWN)

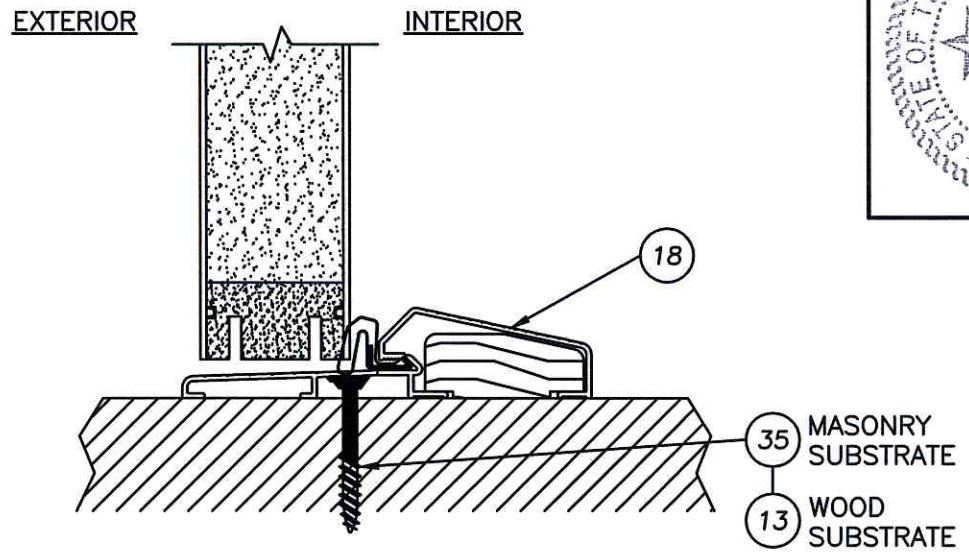

3 VERTICAL CROSS SECTION  
6 OUTSWING CONFIGURATION  
("SMOOTH STAR SERIES" SHOWN)

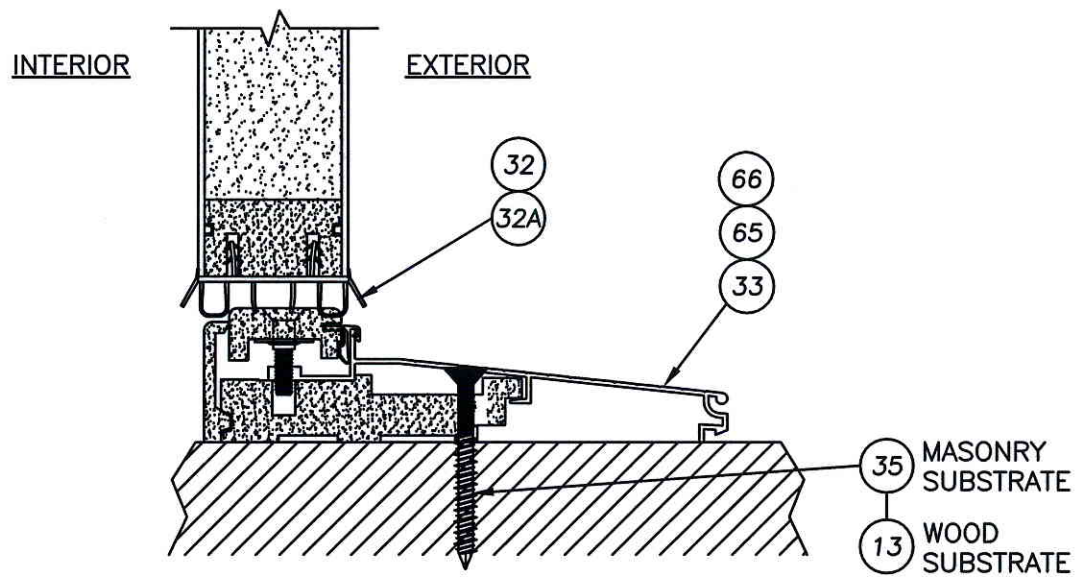

2 VERTICAL CROSS SECTION  
6 INSWING CONFIGURATION  
("SMOOTH STAR SERIES" SHOWN)

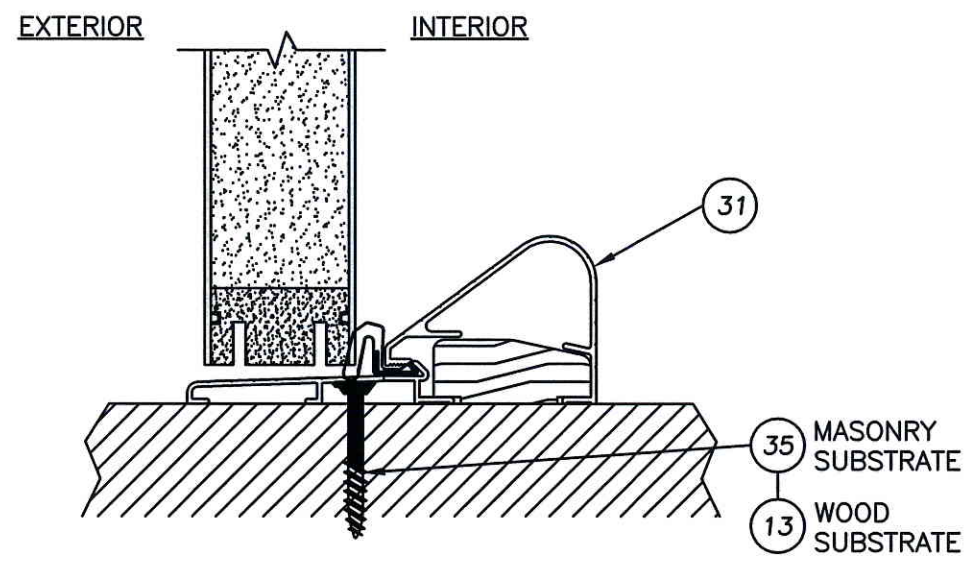

4 VERTICAL CROSS SECTION  
6 OUTSWING CONFIGURATION  
("SMOOTH STAR SERIES" SHOWN)



Documents Prepared By: Lyndon F. Schmidt, P.E.  
TEXAS P.E. #104123

*RW* BUILDING CONSULTANTS, INC.  
P.O. Box 230 Valrico FL 33595  
Phone No.: 813.659.9197

TEXAS BOARD OF PROFESSIONAL ENGINEERS  
CERTIFICATE OF REGISTRATION # F-11852

PRODUCT: THERMA-TRU  
GLAZED FIBERGLASS DOUBLE DOOR  
IN/OUTSWING "IMPACT"  
PART OR ASSEMBLY:  
VERTICAL  
CROSS SECTIONS

REVISIONS		NO.	DATE	BY

DATE: 7/17/12  
SCALE: N.T.S.  
DWG. BY: JK  
CHK. BY: LFS  
DRAWING NO.: TX-4198  
SHEET 6 OF 9

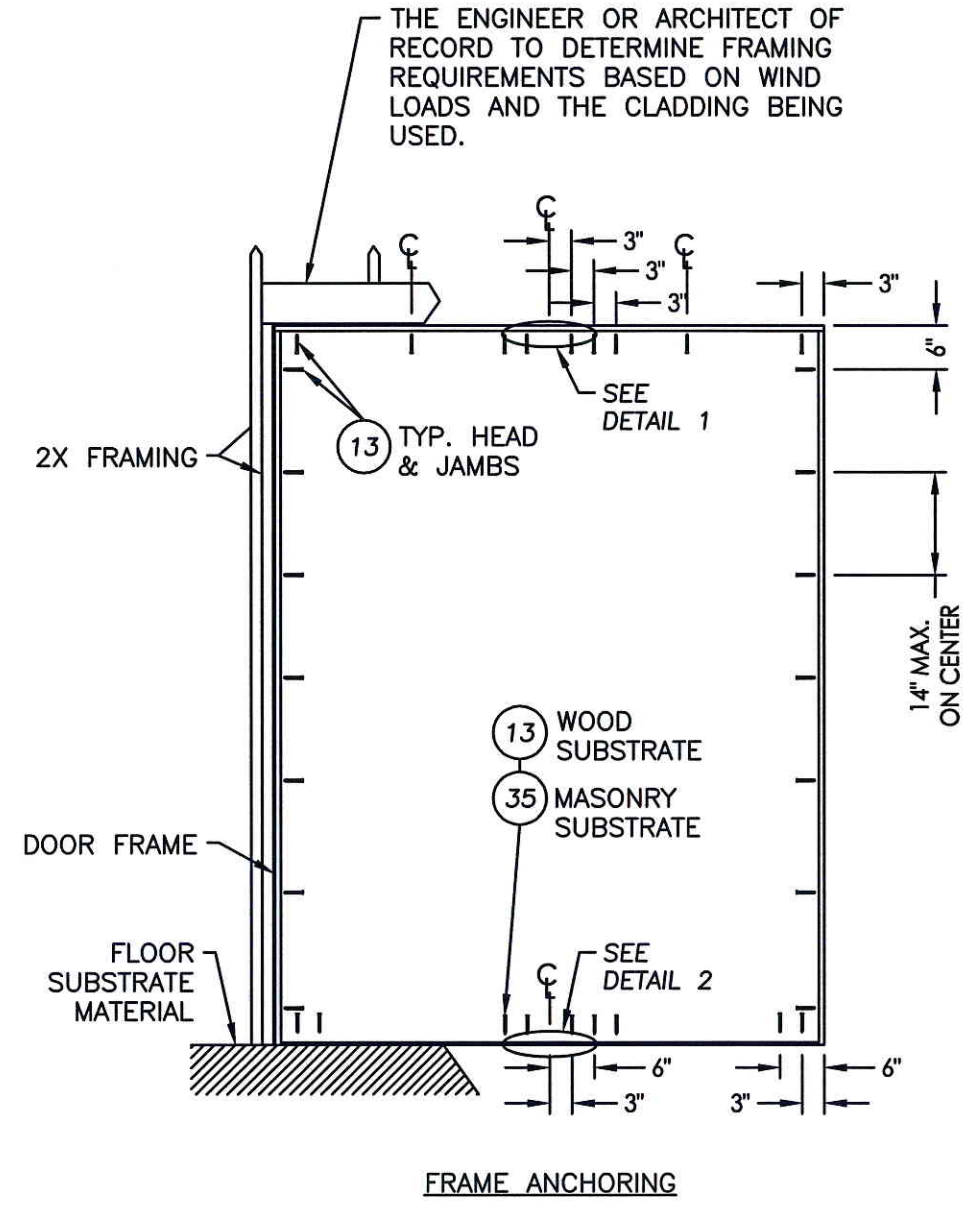

THE ENGINEER OR ARCHITECT OF RECORD TO DETERMINE FRAMING REQUIREMENTS BASED ON WIND LOADS AND THE CLADDING BEING USED.

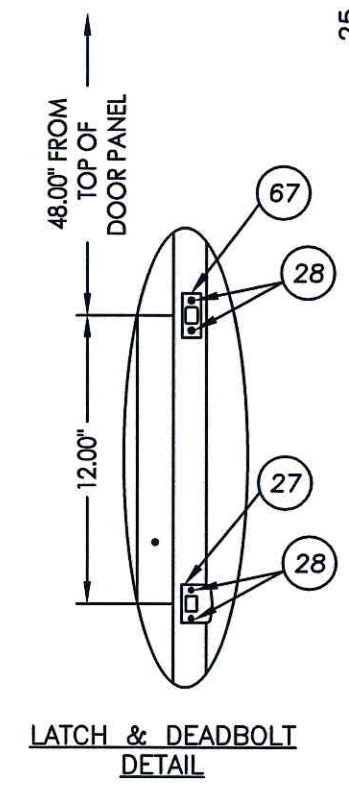
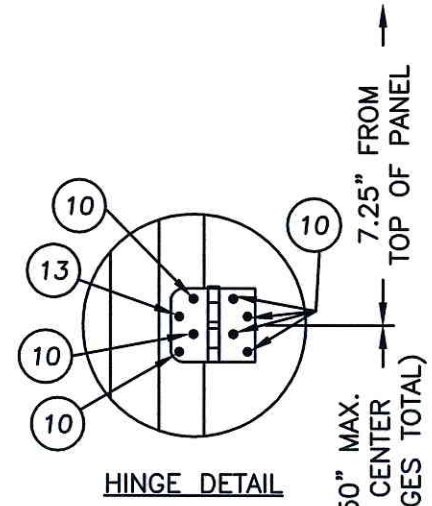
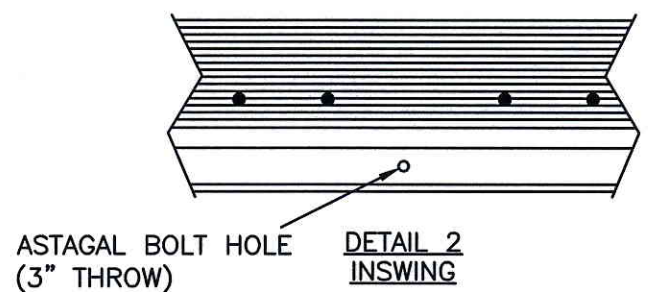
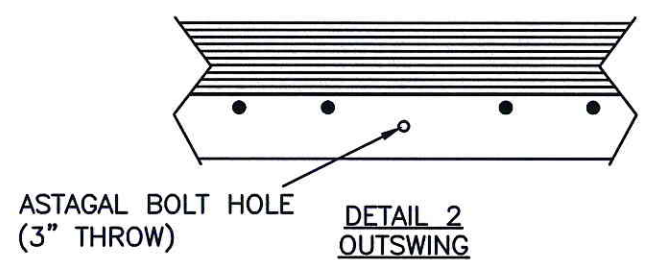
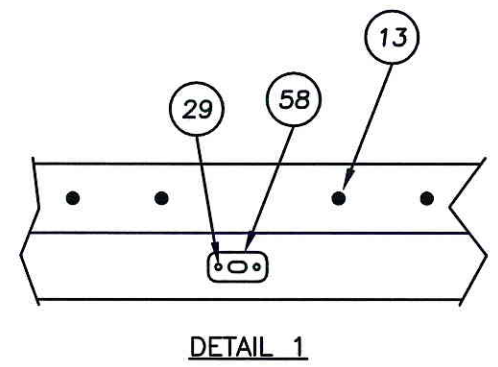

**CONCRETE ANCHOR NOTES:**

1. Concrete anchor locations at the corners may be adjusted to maintain the min. edge distance to mortar joints.
2. Concrete anchor locations noted as "MAX. ON CENTER" must be adjusted to maintain the min. edge distance to mortar joints, additional concrete anchors may be required to ensure the "MAX. ON CENTER" dimension are not exceeded.
3. Concrete anchor table:

ANCHOR TYPE	ANCHOR SIZE	MIN. EMBEDMENT	MIN. CLEARANCE TO MASONRY EDGE	MIN. CLEARANCE TO ADJACENT ANCHOR
ITW TAPCON®	1/4"	1-3/4"	2-1/2"	3"
ELCO ULTRACON®	1/4"	1-3/4"	1"	3"

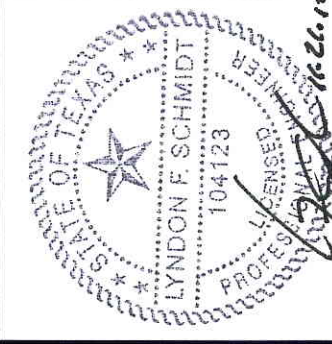

Documents Prepared By: Lyndon F. Schmidt, P.E.  
TEXAS P.E. #104123

**RW** BUILDING CONSULTANTS, INC.  
P.O. Box 230 Valrico FL 33595  
Phone No.: 813.659.9197

TEXAS BOARD OF PROFESSIONAL ENGINEERS  
CERTIFICATE OF REGISTRATION # F-11852

PRODUCT: THERMA-TRU GLAZED FIBERGLASS DOUBLE DOOR IN/OUTSWING IMPACT

PART OR ASSEMBLY: FRAME ANCHORING

NO.	DATE	BY	REVISIONS

DATE: 7/17/12  
SCALE: N.T.S.  
DWG. BY: JK  
CHK. BY: LFS  
DRAWING NO.: TX-4198  
SHEET 7 OF 9

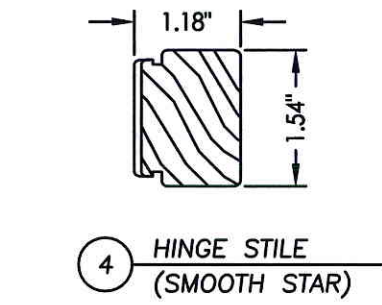

4 HINGE STILE  
(SMOOTH STAR)

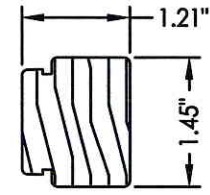

52 HINGE STILE  
(FIBER CLASSIC)

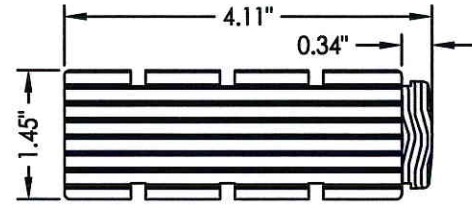

54 LOCK STILE  
(FIBER CLASSIC)

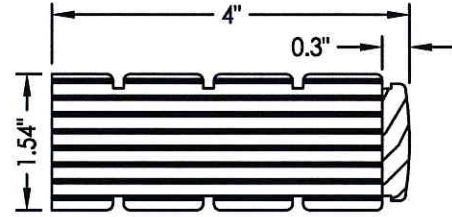

3 LATCH STILE  
(SMOOTH STAR)

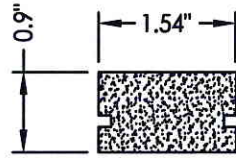

2 DOOR TOP RAIL  
(SMOOTH STAR)

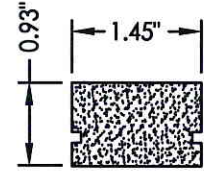

50 DOOR TOP RAIL  
(FIBER CLASSIC)

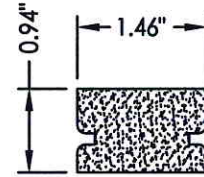

46 DOOR TOP RAIL  
(CLASSIC CRAFT  
& RUSTIC)

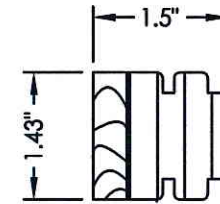

49 HINGE STILE  
(CLASSIC CRAFT  
& RUSTIC)

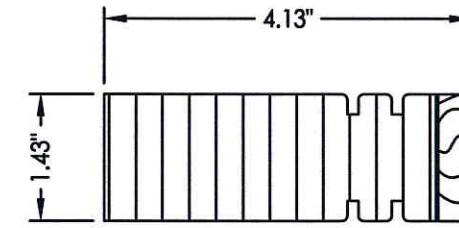

48 LATCH STILE  
(CLASSIC CRAFT  
& RUSTIC)

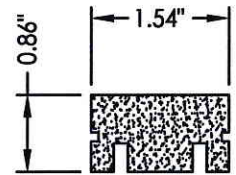

5 BOTTOM RAIL DOOR  
(SMOOTH STAR)

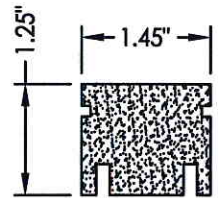

51 DOOR BOTTOM RAIL  
(FIBER CLASSIC)

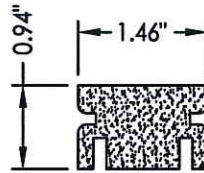

47 DOOR BOTTOM RAIL  
(CLASSIC CRAFT  
& RUSTIC)

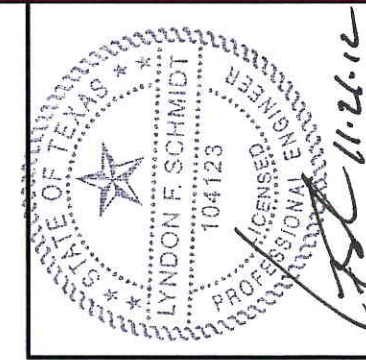

Documents Prepared By: Lyndon F. Schmidt, P.E.  
TEXAS P.E. #104123

RW BUILDING CONSULTANTS, INC.  
P.O. Box 230 Valrico FL 33595  
Phone No.: 813.659.9197

TEXAS BOARD OF PROFESSIONAL ENGINEERS  
CERTIFICATE OF REGISTRATION # F-11852

PRODUCT: THERMA-TRU  
GLAZED FIBERGLASS DOUBLE DOOR  
IN/OUTSWING "IMPACT"  
PART OR ASSEMBLY: COMPONENTS

NO.	DATE	REVISIONS	BY

DATE: 7/17/12  
SCALE: N.T.S.  
DWG. BY: JK  
CHK. BY: LFS  
DRAWING NO.: TX-4198  
SHEET 8 OF 9



Item	DESCRIPTION	Material
1	DOOR SKIN; SMOOTH STAR SERIES (.075" MIN.)	FIBERGLASS
1A	DOOR SKIN; CLASSIC CRAFT & RUSTIC SERIES (.090" MIN.)	FIBERGLASS
1B	DOOR SKIN; FIBER CLASSIC SERIES (.065" MIN.)	FIBERGLASS
2	TOP RAIL DOOR THERMA-TRU (SMOOTH STAR)	COMP.
3	LATCH STILE DOOR THERMA-TRU (SMOOTH STAR)	LVL
4	HINGE STILE / DOOR, STILE / SIDELITE THERMA-TRU (SMOOTH STAR)	WOOD
5	BOTTOM RAIL DOOR THERMA-TRU (SMOOTH STAR)	COMP.
6	POLYURETHANE FOAM (1.9lbs. DENSITY)	FOAM
7	MEDIUM REACH COMPRESSION WEATHER-STRIP (THERMA-TRU)	FOAM
8	LONG REACH COMPRESSION WEATHER-STRIP (THERMA-TRU)	FOAM
9	4" x 4" HINGE .097" THK. (THERMA-TRU)	STEEL
10	#10 x 3/4" PFH WOOD SCREW (Hinge to Frame)	STEEL
11	#10 x 1-1/2" PPH SHEET METAL SCREW	STEEL
12	#10 x 2" PFH WOOD SCREW	STEEL
13	#10 x 2-1/2" PFH WOOD SCREW	STEEL
14	2X FRAMING (G>= 0.42)	WOOD
16	MAX. 1/4" SHIM MATERIAL	WOOD
17	LOCK - KWIKSET 200 SERIES	STEEL
18	THRESHOLD OUTSWING (THERMA-TRU)	ALUM./WOOD
19	HEADER JAMB (4.656" x 1.25" THERMA-TRU, PINE)	WOOD
20	SIDE JAMB (4.656" x 1.25" THERMA-TRU) (FJ PINE)	WOOD
21	DEADBOLT - KWIKSET 780 SERIES	STEEL
22	INTERIOR LITE FRAME	ALUM.
23	EXTERIOR LITE FRAME	ALUM.
25	SILICONE CAULK	SILICONE
26	CELLULAR GLAZING TAPE	FOAM
27	LATCH STRIKE	STEEL
28	#8 x 2-1/2" PFH WOOD SCREW	STEEL
29	#8 x 3" PFH SCREW	STEEL
30	1" THK. INSUL. LAMINATED GLASS (INTERLAYER BY SOLUTIA) 1/8" TEMP.- AIR - 5/32" ANN. / .090" INTERLAYER / 1/8" ANN.	GLASS
31	OUTSWING THRESHOLD COASTAL	ALUM./WOOD
32	DOOR BOTTOM SWEEP (INSWING)	PVC
32A	DOOR BOTTOM SWEEP (INSWING)	PVC
33	INSWING THRESHOLD HPA	ALUM./COMP.
35	1/4" ELCO OR ITW CONCRETE SCREW (1-3/4" MIN. EMB.)	STEEL
39	LITE FRAME TRIM	PVC
40	#9 x 3" PFH WOOD SCREW	STEEL
46	TOP RAIL (CLASSIC CRAFT & RUSTIC)	COMP.
47	BOTTOM RAIL (CLASSIC CRAFT & RUSTIC)	COMP.
48	LATCH SIDE STILE (CLASSIC CRAFT & RUSTIC)	LSL / OAK
49	HINGE SIDE STILE (CLASSIC CRAFT & RUSTIC)	LSL / OAK
50	TOP RAIL (FIBER CLASSIC)	COMP.
51	BOTTOM RAIL (FIBER CLASSIC)	COMP.
52	HINGE SIDE STILE (FIBER CLASSIC)	WOOD
54	LATCH SIDE STILE (FIBER CLASSIC)	LVL / OAK
57	ASTRAGAL (6063-T5) COASTAL	ALUM.
58	ASTRAGAL STRIKE PLATE	STEEL
65	INSWING THRESHOLD SELF ADJUSTING	ALUM./COMP.
66	INSWING THRESHOLD IMPERIAL	ALUM./COMP.
67	DEAD BOLT STRIKE PLATE	STEEL

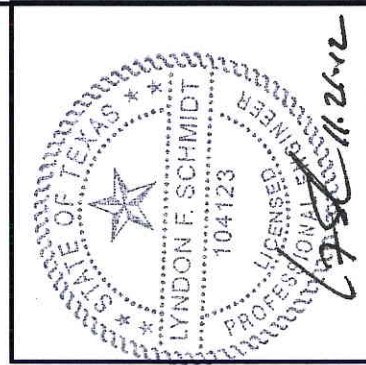
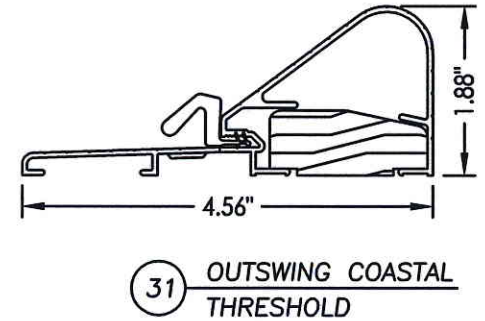
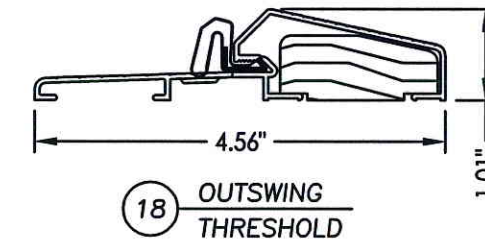
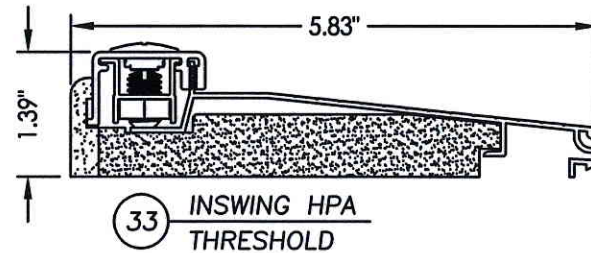
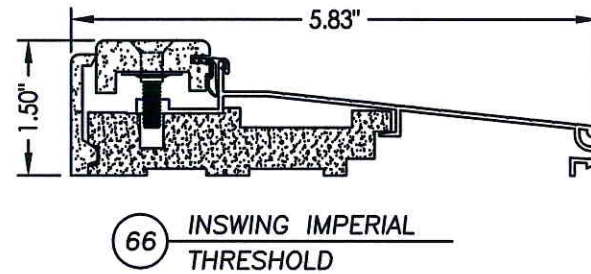
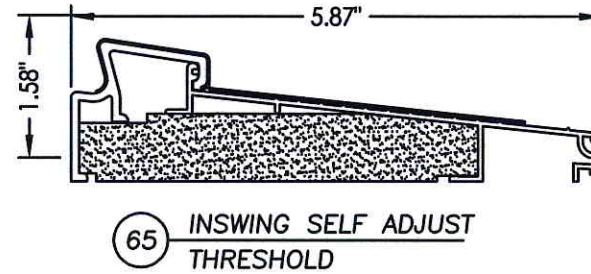
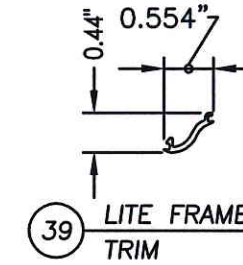
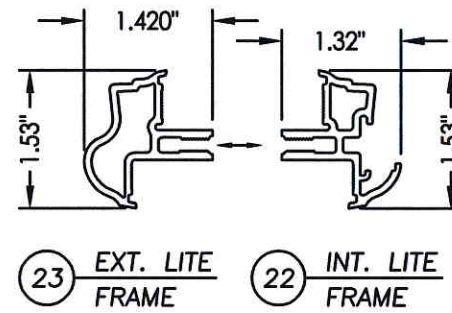
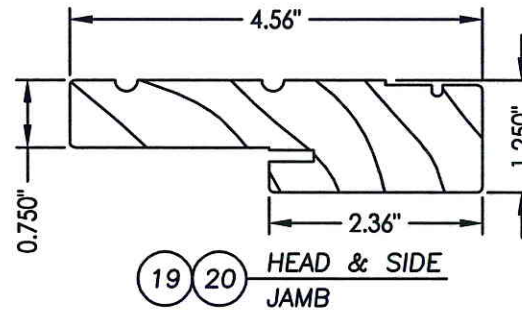
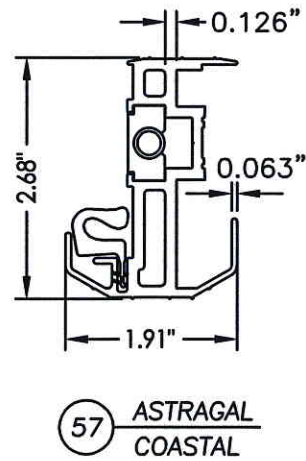
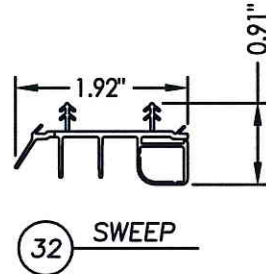
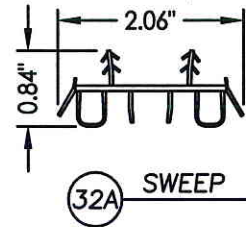

Documents Prepared By: Lyndon F. Schmidt, P.E.  
TEXAS P.E. #104123

**RW** BUILDING CONSULTANTS, INC.  
P.O. Box 230 Vailico FL 33595  
Phone No.: 813.659.9197

TEXAS BOARD OF PROFESSIONAL ENGINEERS  
CERTIFICATE OF REGISTRATION # F-11852

PRODUCT: THERMA-TRU  
FIBERGLASS DOUBLE DOOR W/  
SIDELITES IN/OUTSWING "IMPACT"  
PART OR ASSEMBLY:  
BILL OF MATERIAL &  
COMPONENTS

NO.	DATE	BY	REVISIONS

DATE: 7/17/12  
SCALE: N.T.S.  
DWG. BY: JK  
CHK. BY: LFS  
DRAWING NO.: TX-4198  
SHEET 9 OF 9