

THERMA TRU®

118 INDUSTRIAL DR., EDGERTON, OH 43517

"SMOOTH-STAR", "FIBER-CLASSIC", "CLASSIC-CRAFT" & "CLASSIC-CRAFT RUSTIC" GLAZED FIBERGLASS SINGLE DOOR w/ SIDELITES IN SWING / OUT SWING "IMPACT"

EVALUATED FOR USE IN THE STATE OF TEXAS

The Fiberglass Door system described herein complies with the 2018 International Residential Code (IRC), Sections R301 & R609 and the 2018 International Building Code (IBC), Sections 1404.13, 1609, 1709.5, 2403 and 2404 subject to the following conditions:

1. Anchors shall be as listed and spaced as shown in the details. Anchor embedment to base material shall be beyond wall dressing or stucco.
2. This system has been tested and evaluated as a large missile impact protective system for installation in areas that require wind borne debris protection. This product meets missile level "D" as defined in ASTM E 1996.
3. Allowable design pressure requirements must be equal to or less than the design pressure rating shown in the design pressure chart, sheet 1 of this drawing.
4. Conditions not covered by this drawing are subject to further engineering analysis.
5. Fiber-Classic and Smooth-Star Door and Sidelite panels require the use of "J" part numbers. These door and sidelite panels must be stained or painted within six months of installation.

TABLE OF CONTENTS	
SHEET #	DESCRIPTION
1	TYPICAL ELEVATION, DESIGN PRESSURES & GENERAL NOTES
2	"SMOOTH-STAR" DOOR/SIDELITE PANEL DETAILS
3	"CLASSIC-CRAFT" & "CLASSIC-CRAFT RUSTIC" DOOR/SIDELITE PANEL DETAILS
4	"FIBER-CLASSIC" DOOR/SIDELITE PANEL DETAILS
5	HORIZONTAL CROSS SECTIONS
6	VERTICAL CROSS SECTIONS
7	VERTICAL CROSS SECTIONS
8	FRAME ANCHORING
9	COMPONENTS
10	BILL OF MATERIALS & COMPONENTS

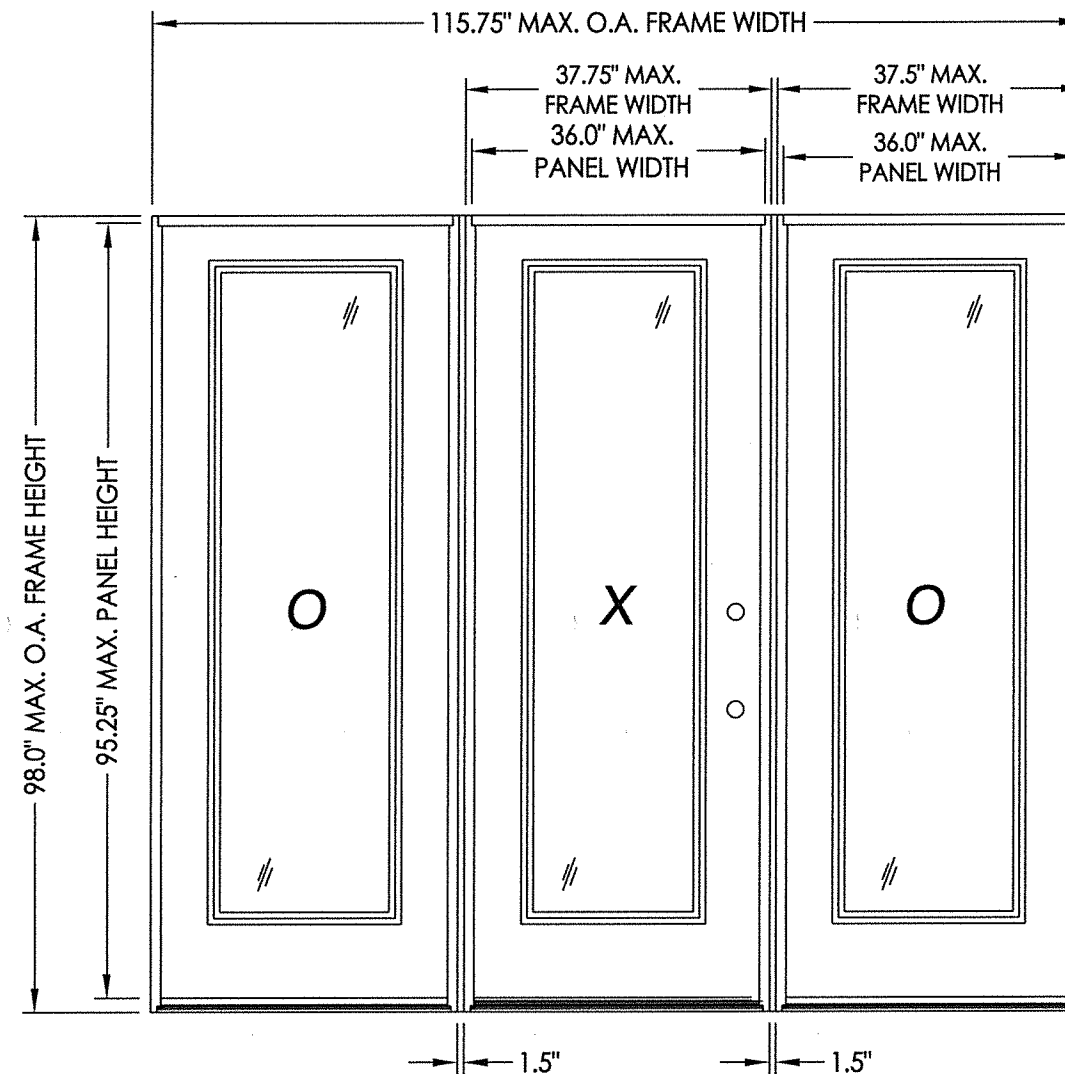

"SMOOTH-STAR", "FIBER-CLASSIC"
"CLASSIC-CRAFT" & "CLASSIC-CRAFT RUSTIC"

SWING	OVERALL FRAME DIMENSION	OVERALL D.L.O. DOOR / SIDELITE DIMENSION	DESIGN PRESSURE (PSF)	
			POSITIVE	NEGATIVE
IN SWING	115.75" X 98.0"	21.0" X 78.75"	+47.0	-47.0
OUT SWING	115.75" X 96.75"	21.0" X 78.75"	+47.0	-47.0

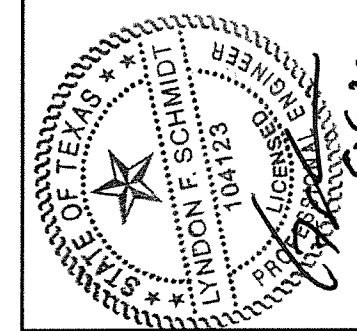

Documents Prepared By: Lyndon F. Schmidt, P.E.
TEXAS P.E. #104123

R.W. BUILDING CONSULTANTS, INC.
P.O. Box 230 Valrico FL 33595
Phone No.: 813.659.9197

TEXAS BOARD OF PROFESSIONAL ENGINEERS
CERTIFICATE OF REGISTRATION # F-11852

PRODUCT:		THERMA-TRU GLAZED FIBERGLASS DOOR w/ SIDELITES IN/OUTSWING "IMPACT"	
PART OR ASSEMBLY:		TYPICAL ELEVATION, DESIGN PRESSURES & GENERAL NOTES	
NO.	DATE	BY	REVISIONS
2	5/06/20	LFS	UPDATE TO 2018 IBC/IRC CODE
1	7/22/15	LFS	ADDED GENERAL NOTE 5.
DATE: 7/17/12			
SCALE: N.T.S.			
DWG. BY: JK			
CHK. BY: LFS			
DRAWING NO.: TX-4197			
SHEET 1 OF 10			

R:\Clients\Therma Tru PERMANENT\B - Texas Dept of Ins\TDI - DR 599 - 80 Glazed FG Imp IS - OS Sgls Dbis w-wo Imp SL\C - Drawings\Current\TX-4195-99.dwg, 2.7

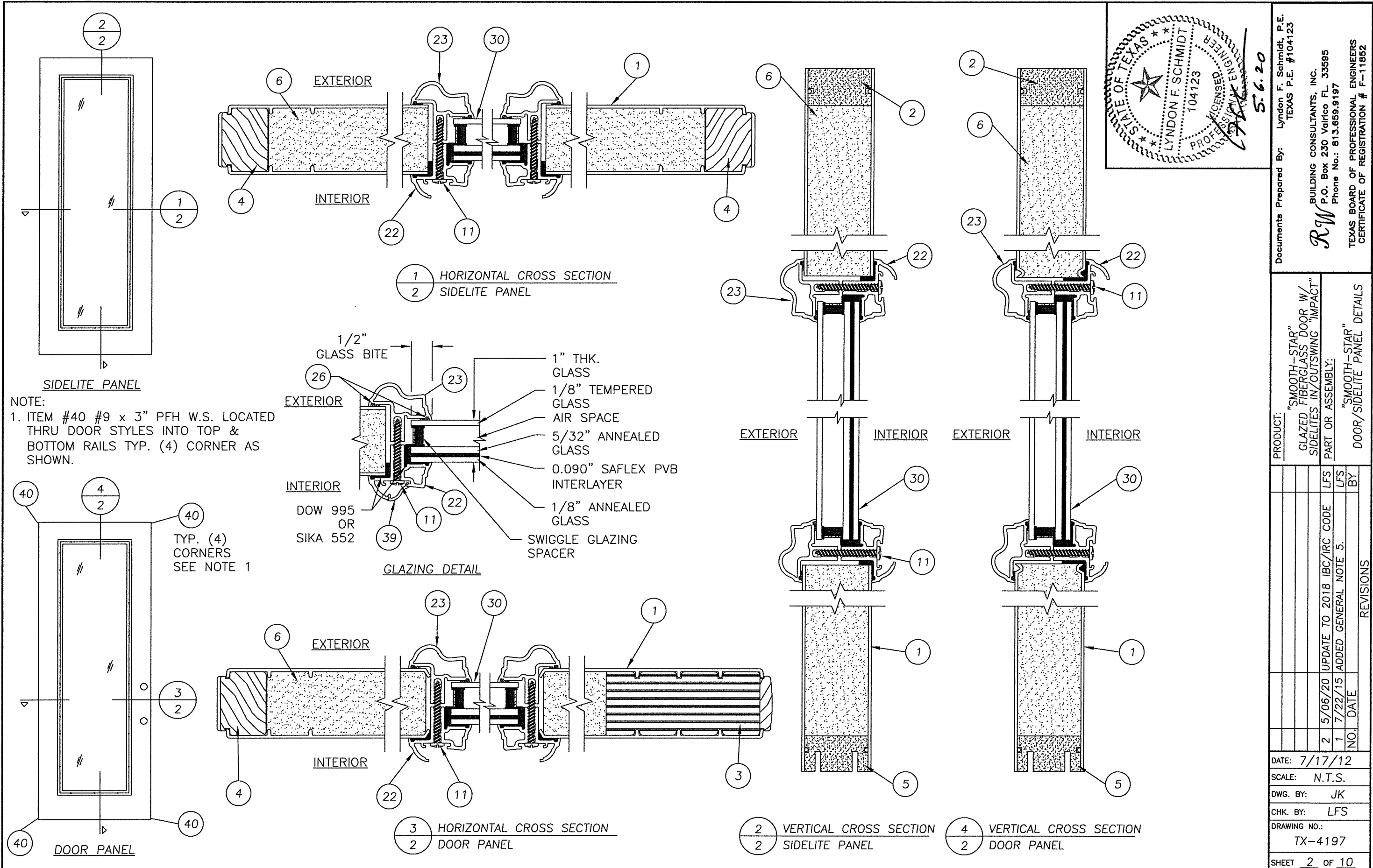

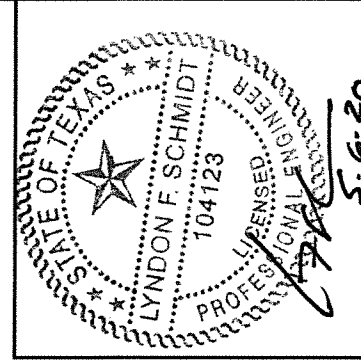
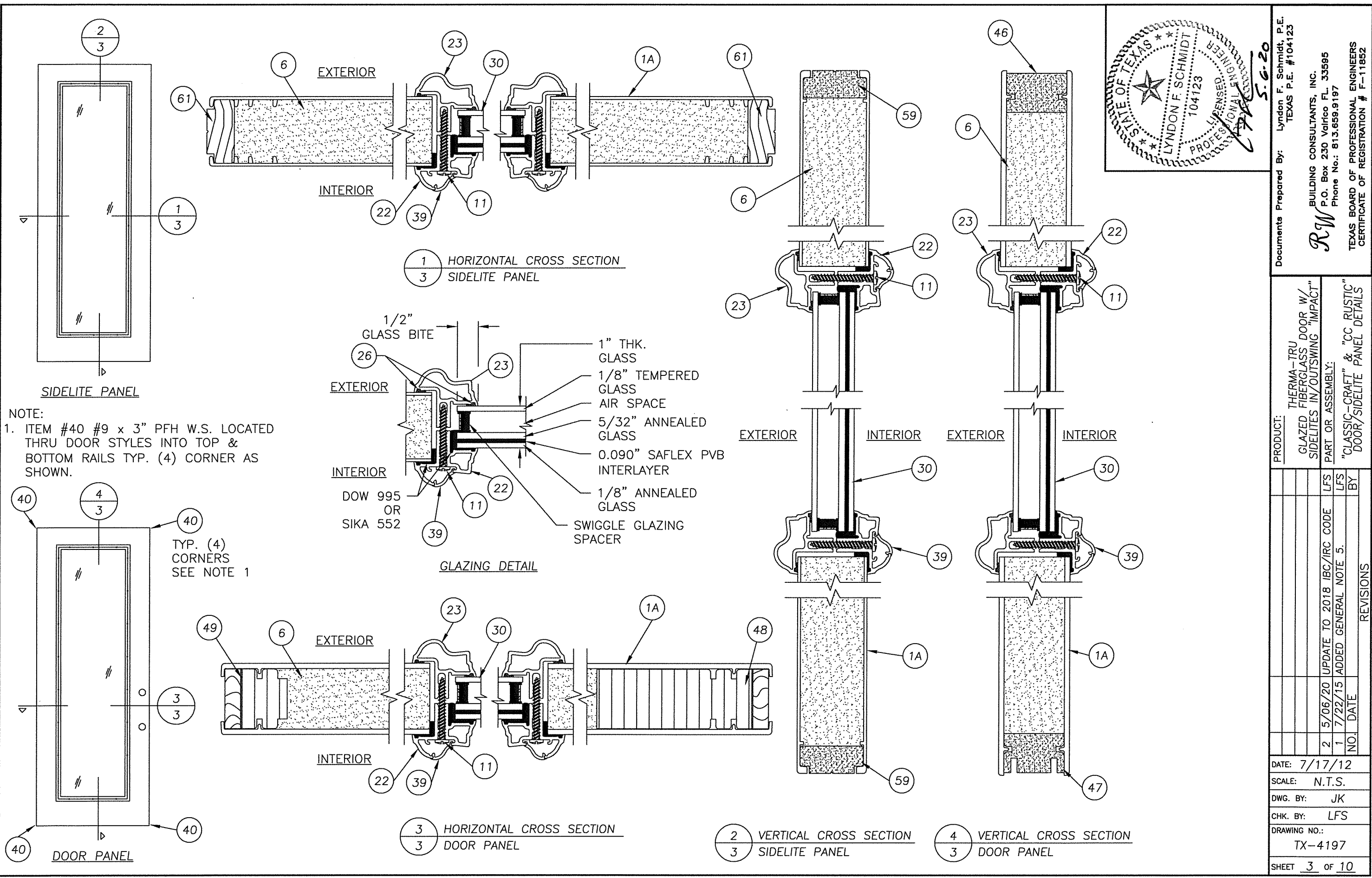

Documents Prepared By: Lyndon F. Schmidt, P.E.
TEXAS P.E. #104123

RW BUILDING CONSULTANTS, INC.
P.O. Box 230 Vairico FL 33595
Phone No.: 813.659.9197

TEXAS BOARD OF PROFESSIONAL ENGINEERS
CERTIFICATE OF REGISTRATION # F-11852

PRODUCT:		THERMA-TRU DOOR W/ GLAZED FIBERGLASS DOOR W/ SIDELITES IN/OUTSWING "IMPACT"	
PART OR ASSEMBLY:		"CLASSIC-CRAFT" & "CC RUSTIC" DOOR/SIDELITE PANEL DETAILS	
NO.	DATE	BY	REVISIONS
2	5/06/20	LFS	UPDATE TO 2018 IBC/IRC CODE
1	7/22/15	LFS	ADDED GENERAL NOTE 5.
DATE: 7/17/12			
SCALE: N.T.S.			
DWG. BY: JK			
CHK. BY: LFS			
DRAWING NO.: TX-4197			
SHEET 3 of 10			

R:\Clients\Therma Tru PERMANENT\B - Texas Dept of Ins\TDI - DR 599 - 80 Glazed FG Imp IS - OS Sgls Dbls w-wo Imp SL\C - Drawings\Current\TX-4195-99.dwg, 4.7

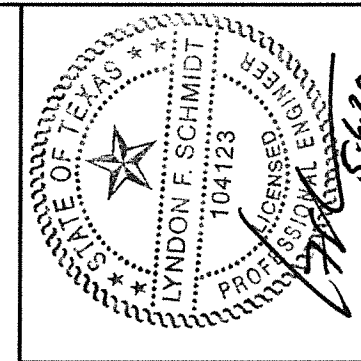
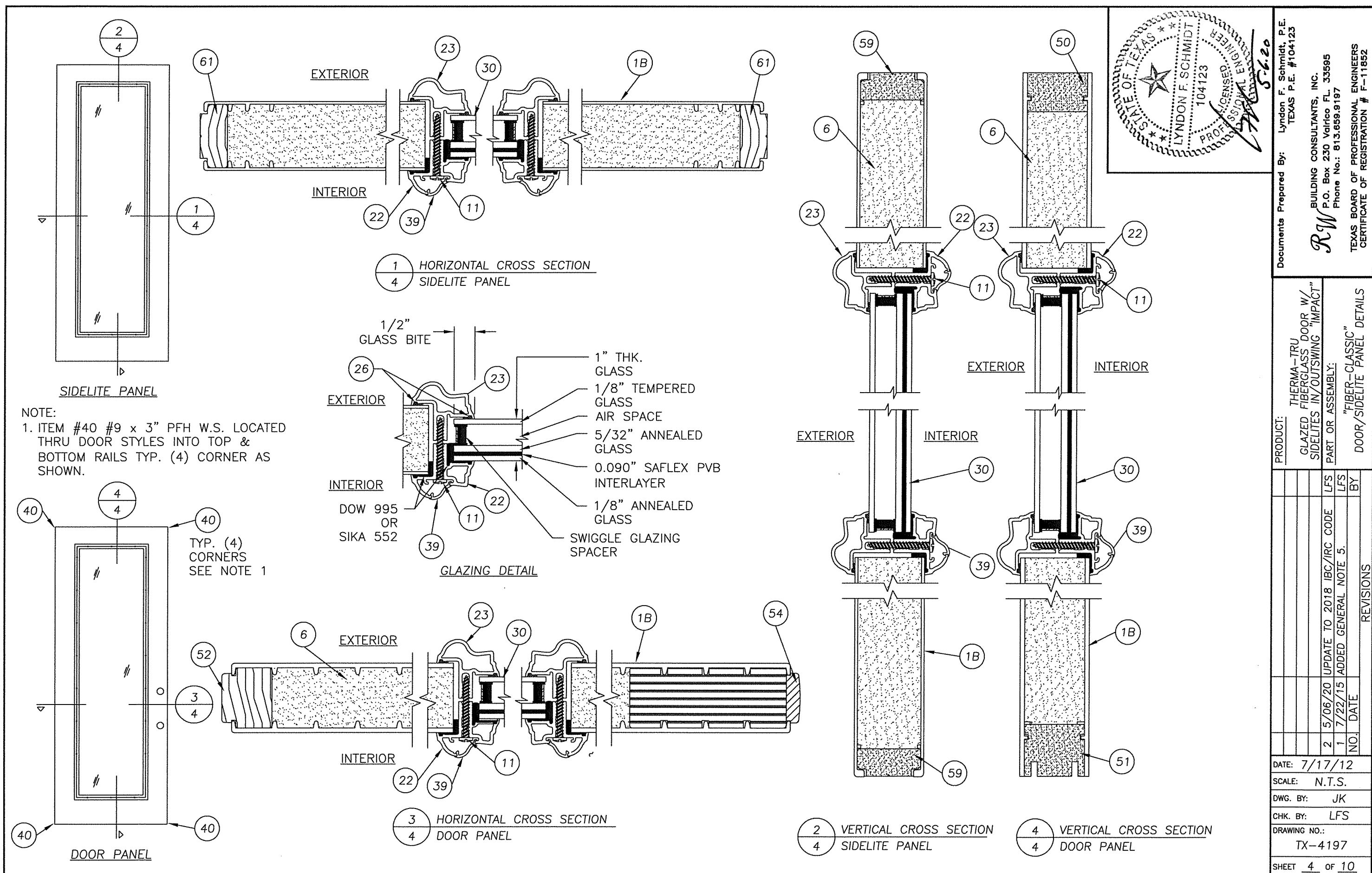

Documents Prepared By: Lyndon F. Schmidt, P.E.
TEXAS P.E. #104123

RW BUILDING CONSULTANTS, INC.
P.O. Box 230 Valrico FL 33595
Phone No.: 813.659.9197

TEXAS BOARD OF PROFESSIONAL ENGINEERS
CERTIFICATE OF REGISTRATION # F-11852

PRODUCT:	THERMA-TRU GLAZED FIBERGLASS DOOR W/ SIDELITES IN/OUTSWING "IMPACT" PART OR ASSEMBLY: "FIBER-CLASSIC" DOOR/SIDELITE PANEL DETAILS	
NO.	DATE	BY
2	5/06/20	LFS
1	7/22/15	LFS
REVISIONS		
DATE:	7/17/12	
SCALE:	N.T.S.	
DWG. BY:	JK	
CHK. BY:	LFS	
DRAWING NO.:	TX-4197	
SHEET	4 OF 10	

© 2012 R.W. BUILDING CONSULTANTS INC.

R:\Clients\Therma Tru PERMANENT\B - Texas Dept of Ins\TDI - DR 599 - 80 Glazed FG Imp IS - OS Sgls Dbis w-wo Imp SL\C - Drawings\Current\TX-4195-99.dwg, 6.7

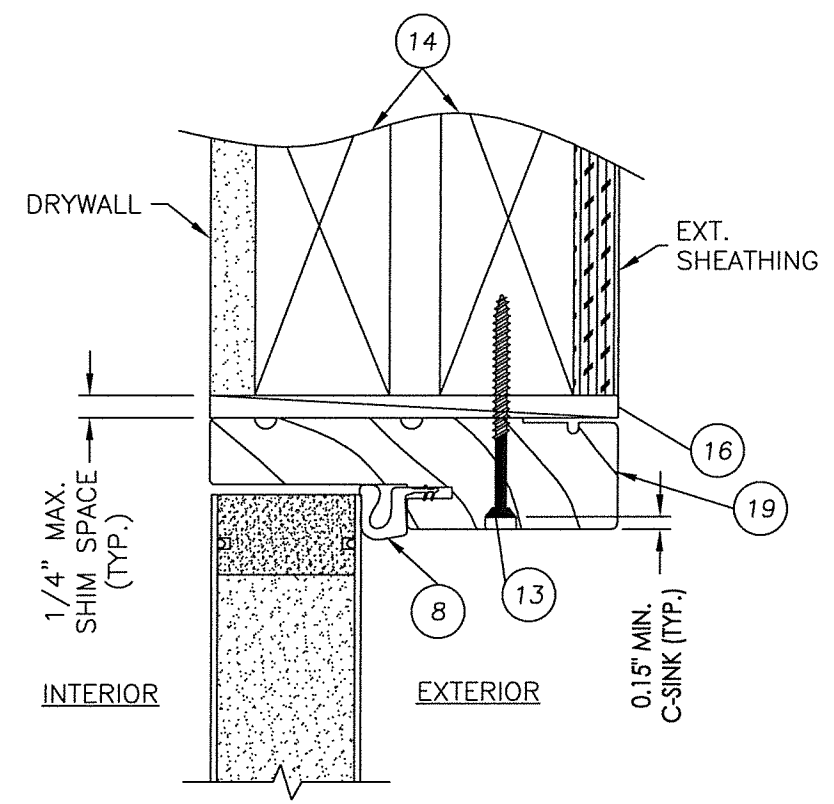

1 VERTICAL CROSS SECTION
6 INSWING SHOWN (OUTSWING ALSO APPROVED)
("SMOOTH-STAR SERIES" SHOWN)

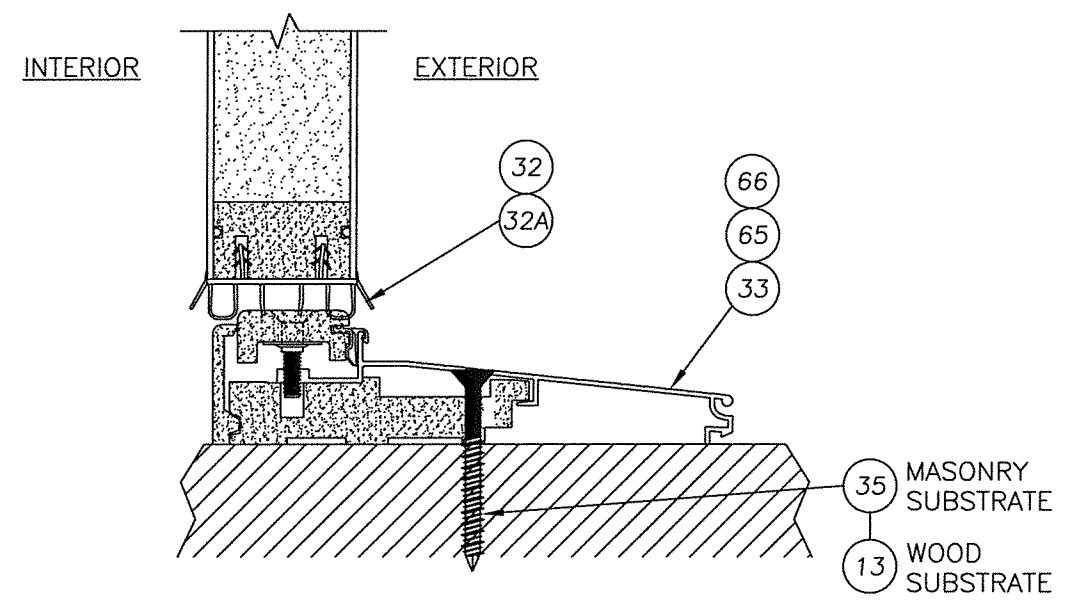

2 VERTICAL CROSS SECTION
6 INSWING CONFIGURATION
("SMOOTH-STAR SERIES" SHOWN)

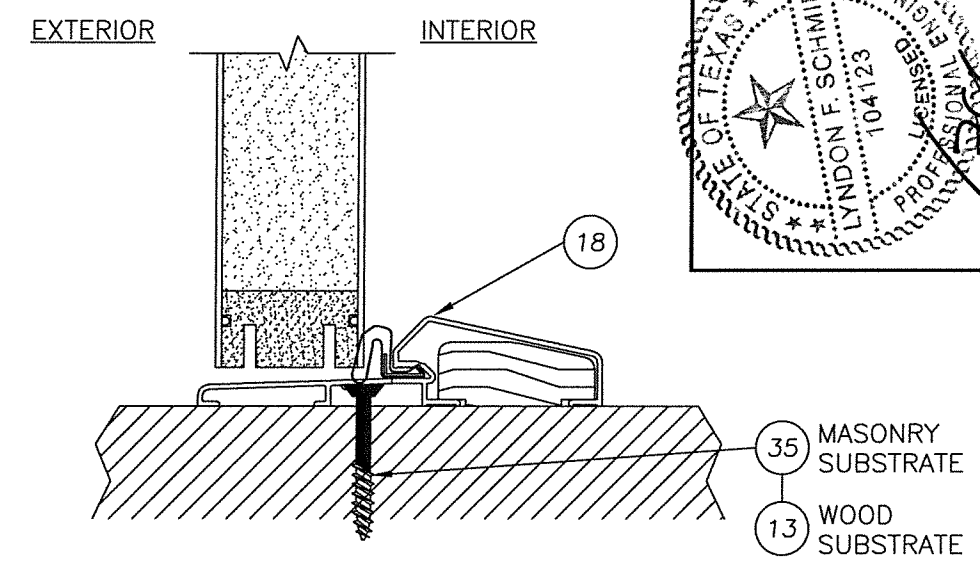

3 VERTICAL CROSS SECTION
6 OUTSWING CONFIGURATION
("SMOOTH-STAR SERIES" SHOWN)

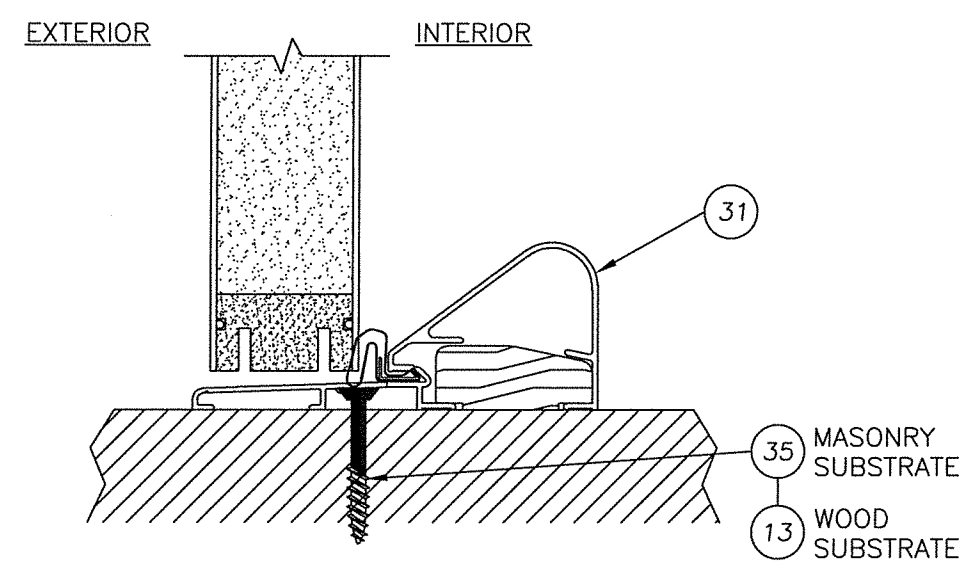

4 VERTICAL CROSS SECTION
6 OUTSWING CONFIGURATION
("SMOOTH-STAR SERIES" SHOWN)

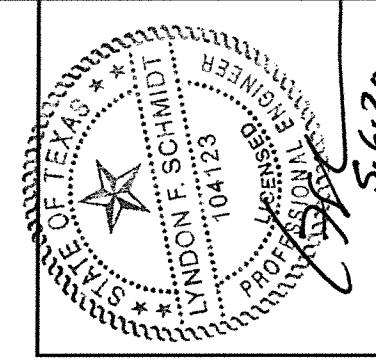

Documents Prepared By: Lyndon F. Schmidt, P.E.
TEXAS P.E. #104123

RW BUILDING CONSULTANTS, INC.
P.O. Box 230 Valrico FL 33595
Phone No.: 813.659.9197

TEXAS BOARD OF PROFESSIONAL ENGINEERS
CERTIFICATE OF REGISTRATION # F-11852

PRODUCT: THERMA-TRU
GLAZED FIBERGLASS DOOR W/
SIDELITES IN/OUTSWING "IMPACT"
PART OR ASSEMBLY: VERTICAL
CROSS SECTIONS

NO.	DATE	REVISIONS
2	5/06/20	UPDATE TO 2018 IBC/IRC CODE
1	7/22/15	ADDED GENERAL NOTE 5.
		LFS BY

DATE: 7/17/12
SCALE: N.T.S.
DWG. BY: JK
CHK. BY: LFS
DRAWING NO.: TX-4197
SHEET 6 of 10

© 2012 R.W. BUILDING CONSULTANTS INC.

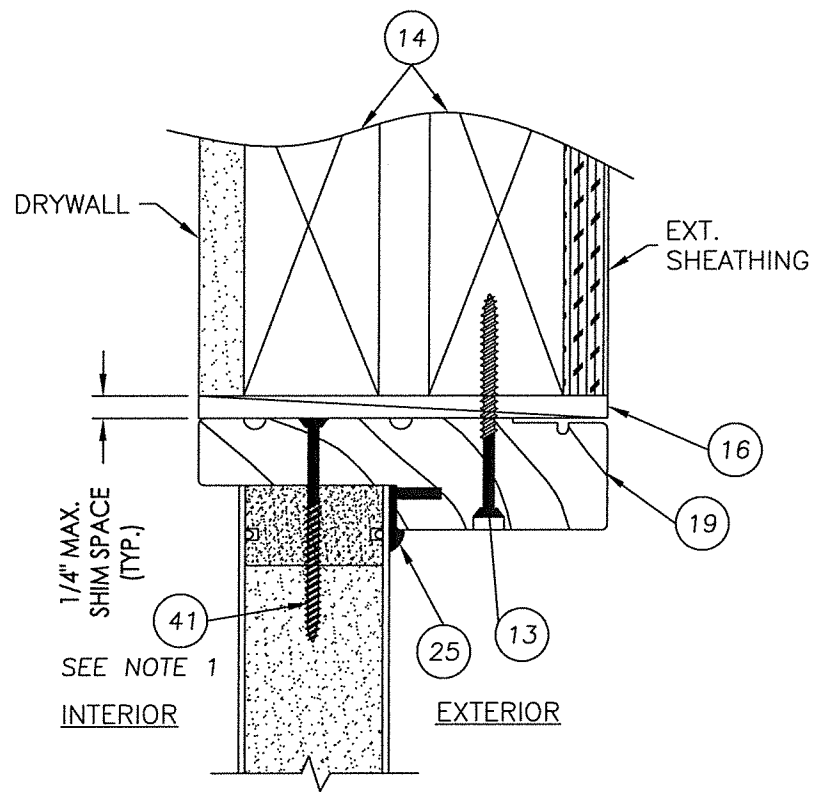

1 VERTICAL CROSS SECTION
7 INSWING SHOWN (OUTSWING ALSO APPROVED)
("SMOOTH-STAR SERIES" SHOWN)

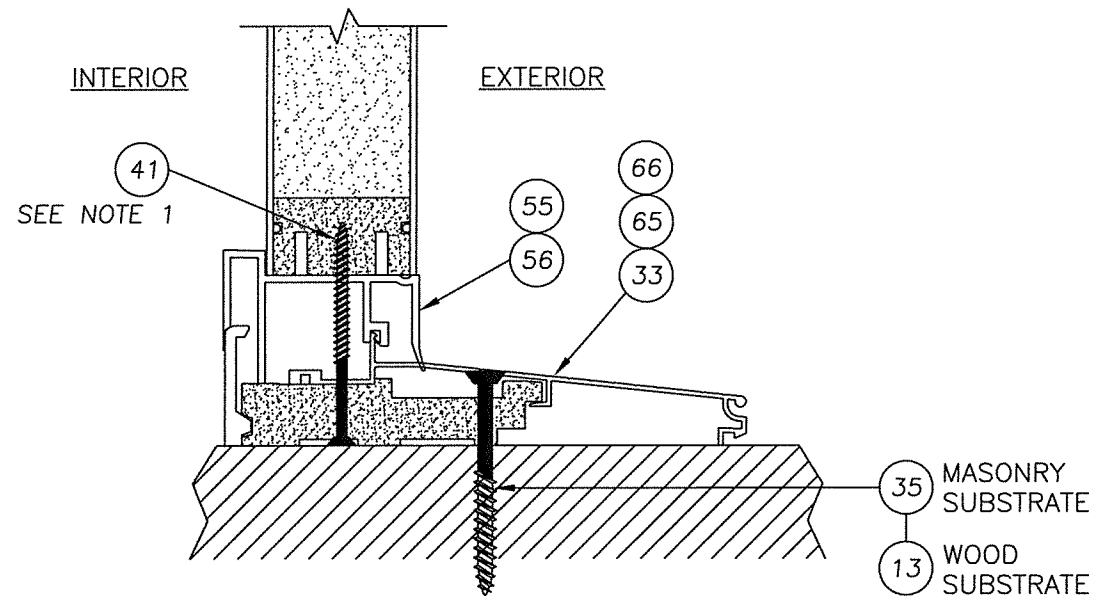

2 VERTICAL CROSS SECTION
7 INSWING CONFIGURATION
("SMOOTH-STAR SERIES" SHOWN)

NOTE:
1. SIDELITE ASSEMBLY FASTENERS LOCATED
6" FROM ENDS PLUS ONE AT CENTERLINE
(3 TOTAL).

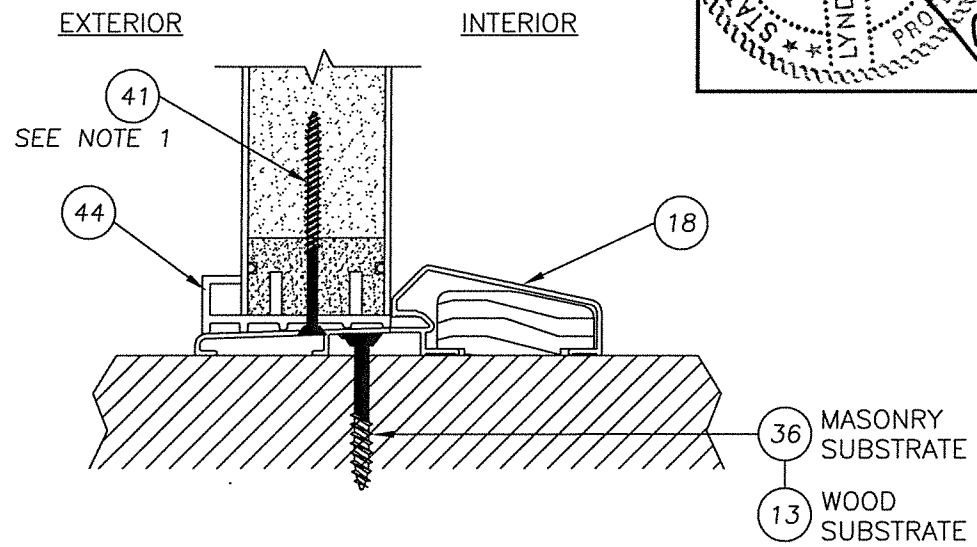

3 VERTICAL CROSS SECTION
7 OUTSWING CONFIGURATION
("SMOOTH-STAR SERIES" SHOWN)

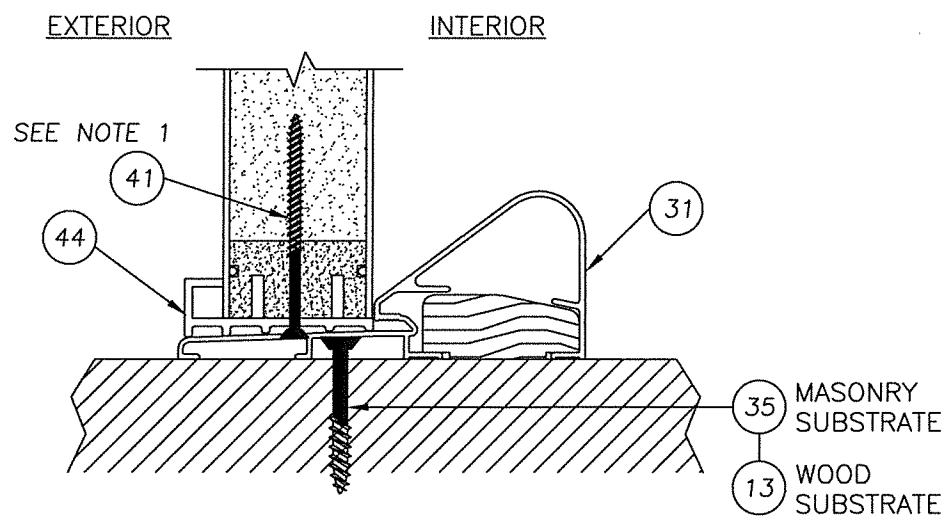

4 VERTICAL CROSS SECTION
7 OUTSWING CONFIGURATION
("SMOOTH-STAR SERIES" SHOWN)

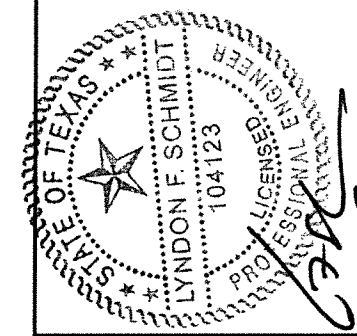

Documents Prepared By: Lyndon F. Schmidt, P.E.
TEXAS P.E. #104123

RW BUILDING CONSULTANTS, INC.
P.O. Box 230 Valrico FL, 33595
Phone No.: 813.659.9197

TEXAS BOARD OF PROFESSIONAL ENGINEERS
CERTIFICATE OF REGISTRATION # F-11852

PRODUCT: THERMA-TRU
GLAZED FIBERGLASS DBL DOOR W/
SIDELITES IN/OUTSWING "IMPACT"
PART OR ASSEMBLY:
VERTICAL
CROSS SECTIONS

NO.	DATE	REVISIONS
2	5/06/20	UPDATE TO 2018 IBC/IRC CODE
1	7/22/15	ADDED GENERAL NOTE 5.
		LFS BY

DATE: 7/17/12

SCALE: N.T.S.

DWG. BY: JK

CHK. BY: LFS

DRAWING NO.: TX-4197

SHEET 7 OF 10

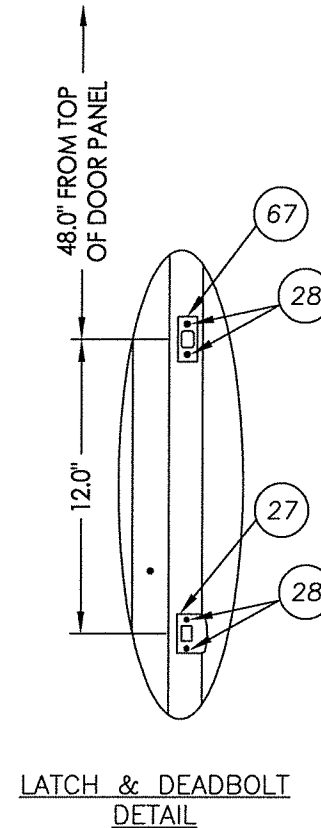
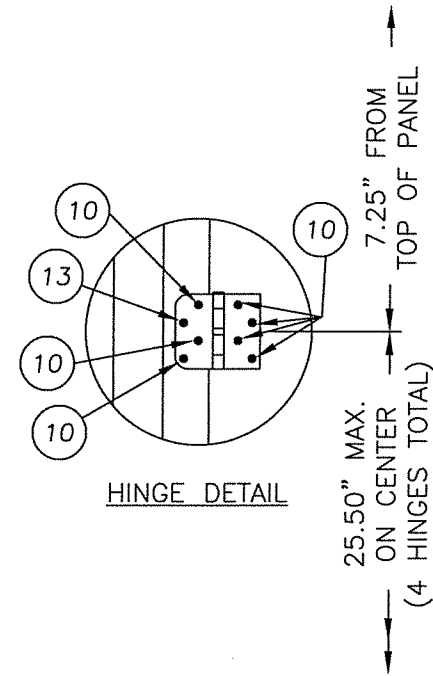
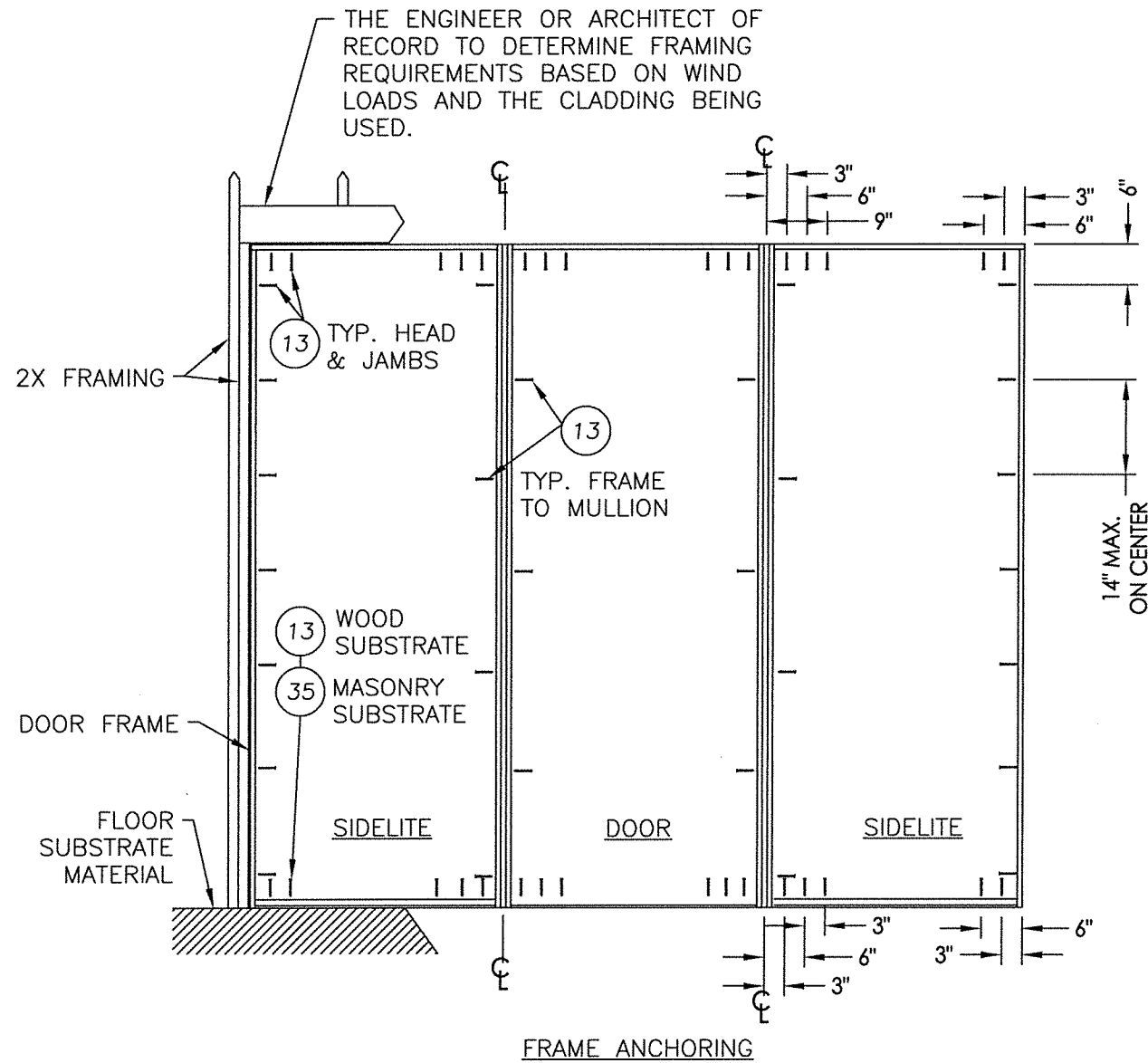

CONCRETE ANCHOR NOTES:

1. Concrete anchor locations at the corners may be adjusted to maintain the min. edge distance to mortar joints.
2. Concrete anchor locations noted as "MAX. ON CENTER" must be adjusted to maintain the min. edge distance to mortar joints, additional concrete anchors may be required to ensure the "MAX. ON CENTER" dimension are not exceeded.
3. Concrete anchor table:

ANCHOR TYPE	ANCHOR SIZE	MIN. EMBEDMENT	MIN. CLEARANCE TO MASONRY EDGE	MIN. CLEARANCE TO ADJACENT ANCHOR
ITW TAPCON®	1/4"	1-3/4"	2-1/2"	3"
ELCO ULTRACON®	1/4"	1-3/4"	1"	3"

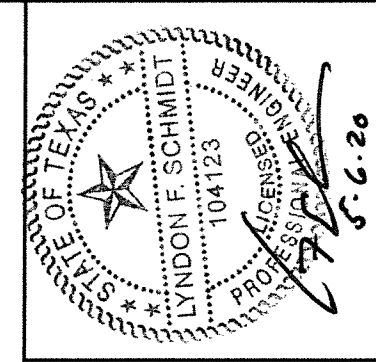

Documents Prepared By: Lyndon F. Schmidt, P.E.
TEXAS P.E. #104123

RW BUILDING CONSULTANTS, INC.
P.O. Box 230 Valrico FL 33595
Phone No.: 813.659.9197

TEXAS BOARD OF PROFESSIONAL ENGINEERS
CERTIFICATE OF REGISTRATION # F-11852

PRODUCT: THERMA-TRU DOOR W/
GLAZED FIBERGLASS SIDELITES IN/OUTSWING "IMPACT"
PART OR ASSEMBLY: FRAME ANCHORING

NO.	DATE	BY	REVISIONS
2	5/06/20	LFS	UPDATE TO 2018 IBC/IRC CODE
1	7/22/15	LFS	ADDED GENERAL NOTE 5.

DATE: 7/17/12
SCALE: N.T.S.
DWG. BY: JK
CHK. BY: LFS
DRAWING NO.: TX-4197
SHEET 8 OF 10

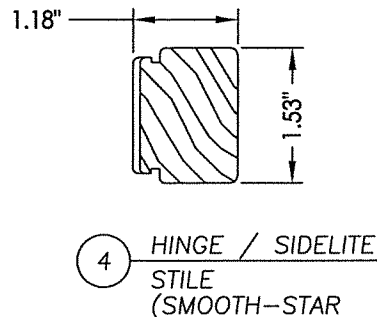

4 HINGE / SIDELITE STILE (SMOOTH-STAR)

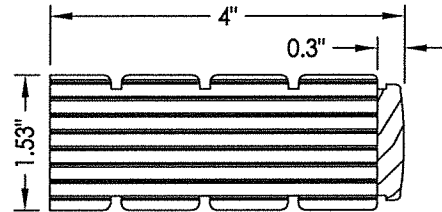

3 LATCH STILE (SMOOTH-STAR)

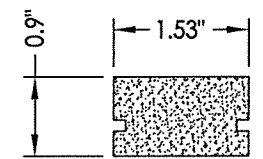

42 SIDELITE TOP RAIL (SMOOTH-STAR)

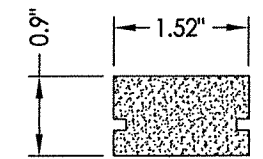

2 DOOR TOP RAIL (SMOOTH-STAR)

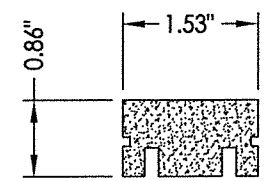

5 BOTTOM RAIL DOOR / SIDELITE (SMOOTH-STAR)

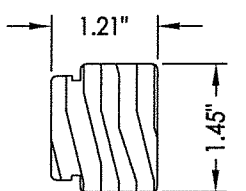

52 HINGE STILE (FIBER-CLASSIC)

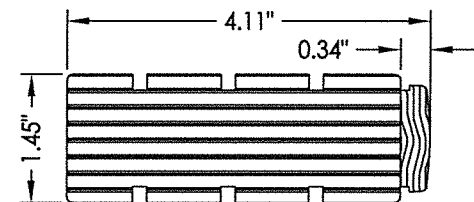

54 LOCK STILE (FIBER-CLASSIC)

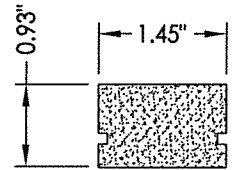

50 DOOR TOP RAIL (FIBER-CLASSIC)

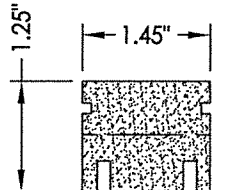

51 DOOR BOTTOM RAIL (FIBER-CLASSIC)

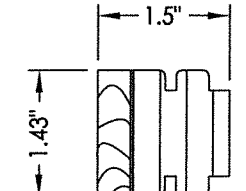

49 HINGE STILE (CLASSIC-CRAFT & RUSTIC)

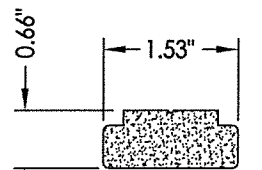

59 SIDELITE TOP & BOTTOM RAIL (CLASSIC-CRAFT & RUSTIC)

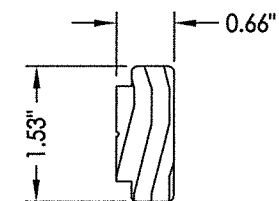

61 SIDELITE STILE (CLASSIC-CRAFT & RUSTIC)

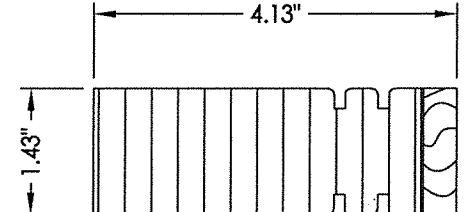

48 LATCH STILE (CLASSIC-CRAFT & RUSTIC)

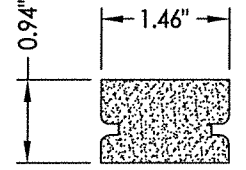

46 DOOR TOP RAIL (CLASSIC-CRAFT & RUSTIC)

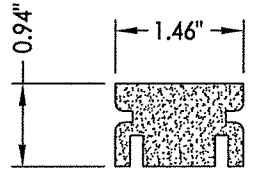

47 DOOR BOTTOM RAIL (CLASSIC-CRAFT & RUSTIC)

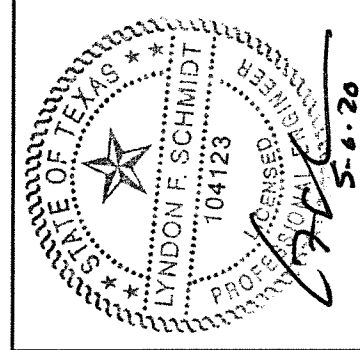

Documents Prepared By: Lyndon F. Schmidt, P.E. TEXAS P.E. #104123

RW BUILDING CONSULTANTS, INC. P.O. Box 230 Valrico FL 33595 Phone No.: 813.659.9197

TEXAS BOARD OF PROFESSIONAL ENGINEERS CERTIFICATE OF REGISTRATION # F-11852

PRODUCT:		THERMA-TRU GLAZED FIBERGLASS DOOR W/ SIDELITES IN/OUTSWING "IMPACT"	
PART OR ASSEMBLY:		COMPONENTS	
NO.	DATE	LFS	BY
2	5/06/20	UPDATE TO 2018 IBC/IRC CODE	LFS
1	7/22/15	ADDED GENERAL NOTE 5.	LFS
REVISIONS			
DATE: 7/17/12			
SCALE: N.T.S.			
DWG. BY: JK			
CHK. BY: LFS			
DRAWING NO.: TX-4197			
SHEET 9 OF 10			

R:\Clients\Therma Tru PERMANENT\B - Texas Dept of Ins\TDI - DR 599 - 80 Glazed FG Imp IS - OS Sgls Dbls w-wo Imp SLC - Drawings\Current\TX-4195-99.dwg, 10.7

Item	DESCRIPTION	Material
1	DOOR SKIN; SMOOTH-STAR SERIES (.075" MIN.)	FIBERGLASS
1A	DOOR SKIN; CLASSIC-CRAFT & RUSTIC SERIES (0.090" MIN.)	FIBERGLASS
1B	DOOR SKIN; FIBER-CLASSIC SERIES (.065" MIN.)	FIBERGLASS
2	TOP RAIL DOOR THERMA-TRU (SMOOTH-STAR)	COMP.
3	LATCH STILE DOOR THERMA-TRU (SMOOTH-STAR)	LVL
4	HINGE STILE / DOOR, STILE / SIDELITE THERMA-TRU (SMOOTH-STAR)	WOOD
5	BOTTOM RAIL DOOR THERMA-TRU (SMOOTH-STAR)	COMP.
6	POLYURETHANE FOAM (1.9lbs. DENSITY)	FOAM
7	MEDIUM REACH COMPRESSION WEATHER-STRIP (THERMA-TRU)	FOAM
8	LONG REACH COMPRESSION WEATHER-STRIP (THERMA-TRU)	FOAM
9	4" x 4" HINGE .097" THK. (THERMA-TRU)	STEEL
10	#10 x 3/4" PFH WOOD SCREW (Hinge to Frame)	STEEL
12	#10 x 2" PFH WOOD SCREW	STEEL
13	#10 x 2-1/2" PFH WOOD SCREW	STEEL
14	2X FRAMING (G >= 0.42)	WOOD
16	MAX. 1/4" SHIM MATERIAL	WOOD
17	LOCK - KWIKSET 200 SERIES	STEEL
18	THRESHOLD OUTSWING (THERMA-TRU)	ALUM./WOOD
19	HEADER JAMB (4.656" x 1.25" THERMA-TRU, PINE)	WOOD
20	SIDE JAMB (4.656" x 1.25" THERMA-TRU) (FJ PINE)	WOOD
21	DEADBOLT - KWIKSET 780 SERIES	STEEL
22	INTERIOR LITE FRAME	ALUM.
23	EXTERIOR LITE FRAME	ALUM.
24	LOCK BLOCK (SMOOTH-STAR)	WOOD
25	SILICONE CAULK	SILICONE
26	CELLULAR GLAZING TAPE	FOAM
27	LATCH STRIKE	STEEL
28	#8 x 2-1/2" PFH WOOD SCREW	STEEL
29	#8 x 3" PFH SCREW	STEEL
30	1" THK. INSUL. LAMINATED GLASS (SAFLEX PVB INTERLAYER) 1/8" TEMP. - AIR - 5/32" ANN. / 0.090" SAFLEX PVB / 1/8" ANN.	GLASS
31	OUTSWING THRESHOLD COASTAL	ALUM./WOOD
32	DOOR BOTTOM SWEEP (INSWING)	PVC
32A	DOOR BOTTOM SWEEP (INSWING)	PVC
33	INSWING THRESHOLD HPA	ALUM./COMP.
35	1/4" ELCO OR ITW CONCRETE SCREW (1-3/4" MIN. EMB.)	STEEL
39	LITE FRAME TRIM	ALUM.
40	#9 x 3" PFH WOOD SCREW	STEEL
41	#9 x 2-1/2" PFH SCREW	STEEL
44	OUTSWING SIDELITE ADAPTER	PVC
46	TOP RAIL (CLASSIC-CRAFT & RUSTIC)	COMP.
47	BOTTOM RAIL (CLASSIC-CRAFT & RUSTIC)	COMP.
48	LATCH SIDE STILE (CLASSIC-CRAFT & RUSTIC)	LSL / OAK
49	HINGE SIDE STILE (CLASSIC-CRAFT & RUSTIC)	LSL / OAK
50	TOP RAIL (FIBER-CLASSIC)	COMP.
51	BOTTOM RAIL (FIBER-CLASSIC)	COMP.
52	HINGE SIDE STILE (FIBER-CLASSIC)	WOOD
54	LATCH SIDE STILE (FIBER-CLASSIC)	LVL / OAK
55	INSWING SIDELITE SPACER	PVC
56	INSWING SIDELITE SPACER	PVC
59	SIDELITE TOP & BOTTOM RAIL (CLASSIC-CRAFT, RUSTIC & FIBER-CLASSIC)	COMP.
61	SIDELITE STILE (CLASSIC-CRAFT, RUSTIC & FIBER-CLASSIC)	WOOD
65	INSWING THRESHOLD SELF ADJUSTING	ALUM./COMP.
66	INSWING THRESHOLD IMPERIAL	ALUM./COMP.
67	DEAD BOLT STRIKE PLATE	STEEL
69	2X MULLION (G >= 0.42)	WOOD

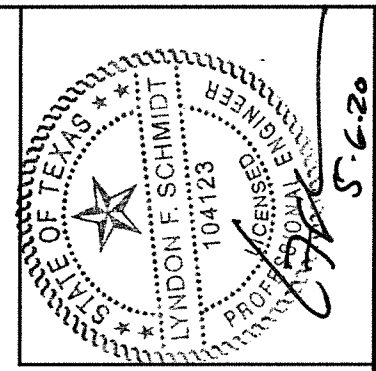
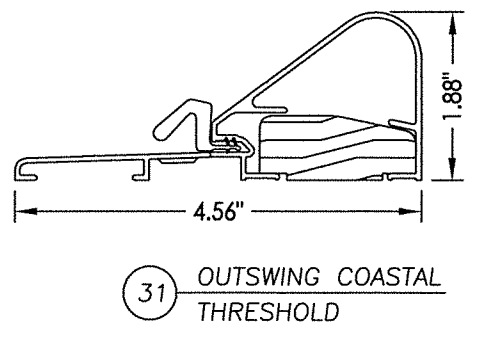
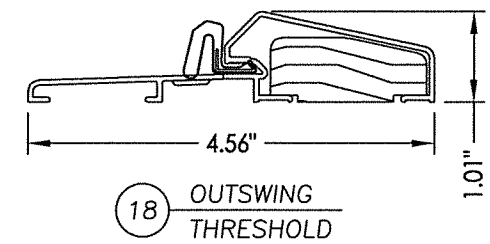
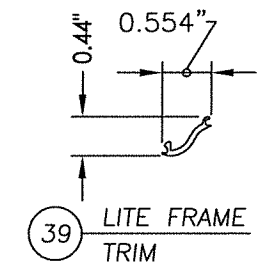
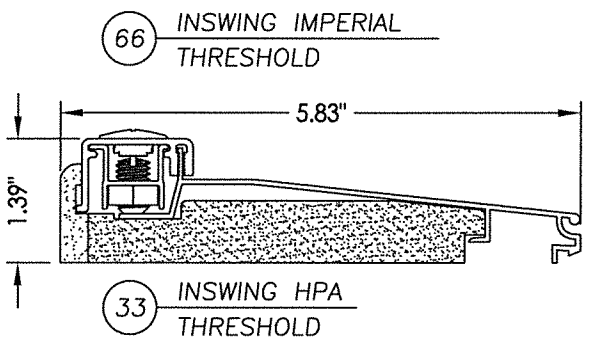
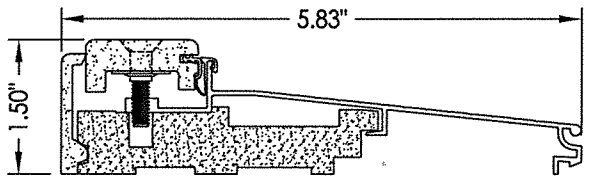
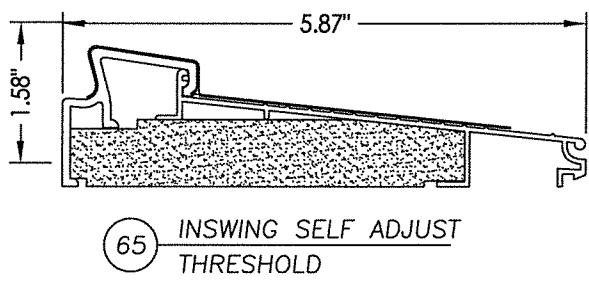
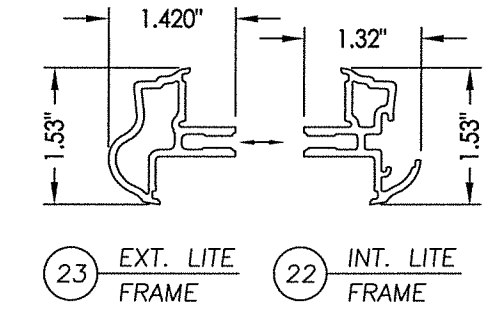
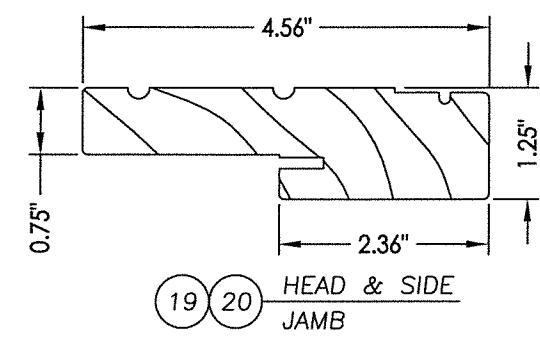
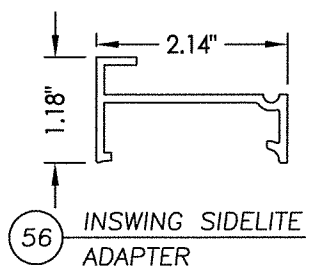
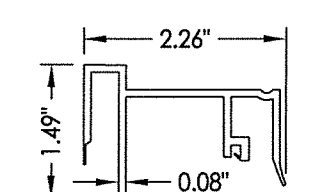
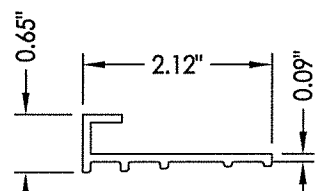
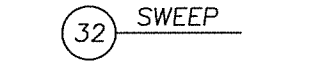
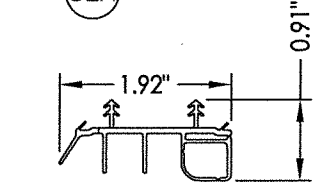
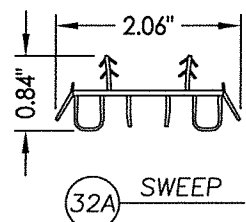

Documents Prepared By: Lyndon F. Schmidt, P.E.
TEXAS P.E. #104123

RW BUILDING CONSULTANTS, INC.
P.O. Box 230 Valrico FL, 33595
Phone No.: 813.659.9197

TEXAS BOARD OF PROFESSIONAL ENGINEERS
CERTIFICATE OF REGISTRATION # F-11852

PRODUCT: THERMA-TRU FIBERGLASS DOOR WITH SIDELITES IN/OUTSWING "IMPACT" PART OR ASSEMBLY: BILL OF MATERIAL & COMPONENTS

NO.	DATE	BY	REVISIONS
2	5/06/20	LFS	UPDATE TO 2018 IBC/IRC CODE
1	7/22/15	LFS	ADDED GENERAL NOTE 5.

DATE: 7/17/12
SCALE: N.T.S.
DWG. BY: JK
CHK. BY: LFS
DRAWING NO.: TX-4197
SHEET 10 of 10