

plastpro

5200 W. CENTURY BLVD.
LOS ANGELES, CA 90045

OPAQUE FIBERGLASS SINGLE DOOR w/ or w/out SIDELITES INSWING / OUTSWING "NON-IMPACT"

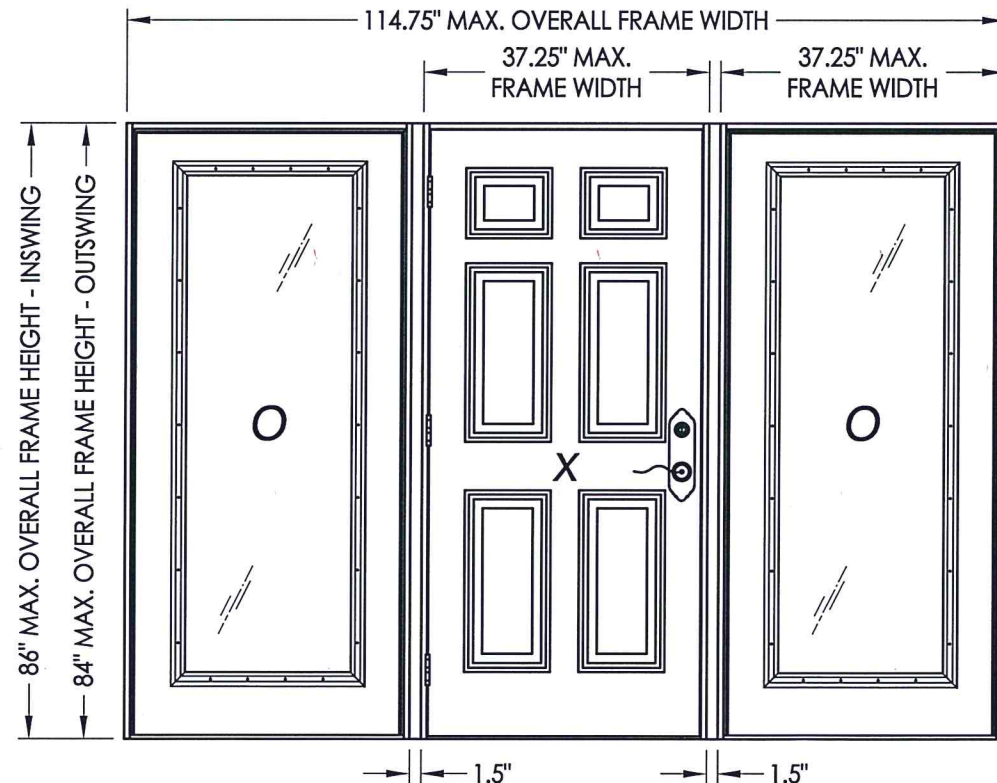
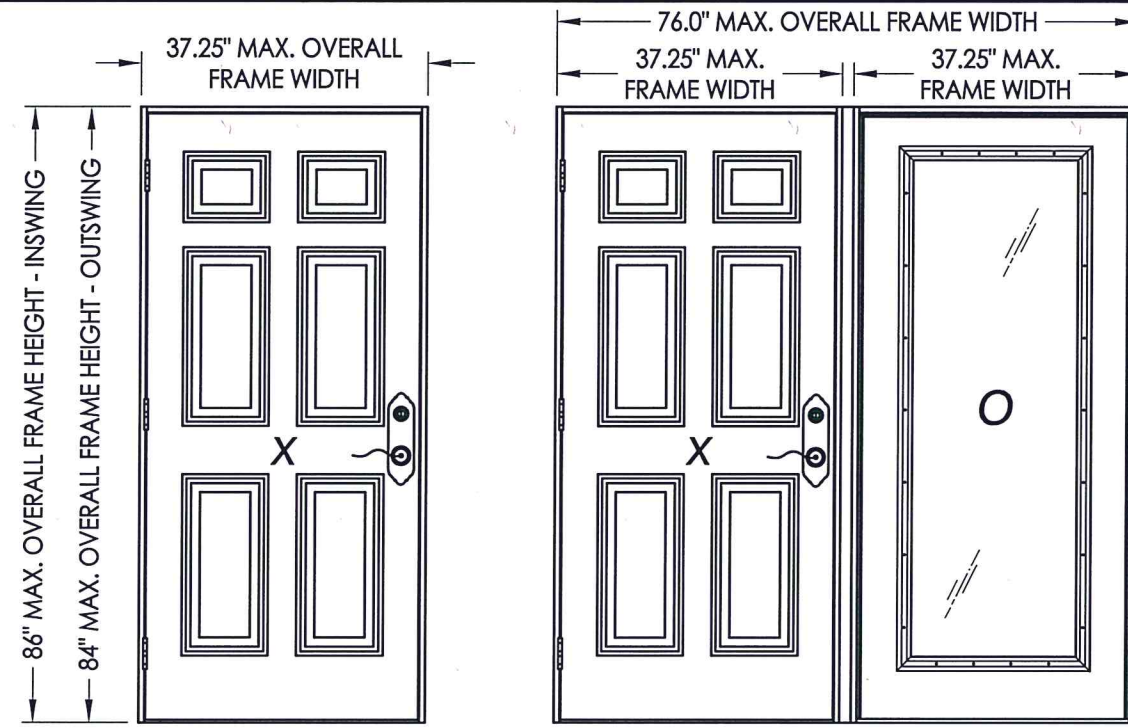

Documents Prepared By: Lyndon F. Schmidt, P.E.
TEXAS P.E. #104123

RW BUILDING CONSULTANTS, INC.
P.O. Box 230 Valrico FL 33595
Phone No.: 813.659.9197

TEXAS BOARD OF PROFESSIONAL ENGINEERS
CERTIFICATE OF REGISTRATION # F-11852

EVALUATED FOR USE IN THE STATE OF TEXAS

The Fiberglass Door system described herein complies with the 2018 International Residential Code (IRC), Sections R301 & R609 and the 2018 International Building Code (IBC), Sections 1404.13, 1609, 1709.5, 2403 and 2404 subject to the following conditions:

1. Anchors shall be as listed and spaced as shown in the details. Anchor embedment to base material shall be beyond wall dressing or stucco.
2. When used in areas requiring wind-borne debris protection this product is required to be protected with an impact resistant covering that complies with Section R301.2.1.2 of the IRC and Section 1609.1.2 of the IBC.
3. Allowable design pressure requirements must be equal to or less than the design pressure rating shown in the design pressure chart, sheet 1 of this drawing.
4. Conditions not covered by this drawing are subject to further engineering analysis.

TABLE OF CONTENTS

SHEET #	DESCRIPTION
1	Typical elevations, design pressures & general notes
2	Door panel
3	Sidelite panel & glazing details
4	Elevations
5	Horizontal cross sections
6	Vertical cross sections
7	Vertical cross sections
8	Frame anchoring
9	Frame anchoring
10	Components, multi-point lock details & bill of materials

CONFIGURATION	MAX. FRAME DIMENSION	MAX. SIDELITE D.L.O. DIMENSION	GLASS TYPE	DESIGN PRESSURE (PSF) INSWING		DESIGN PRESSURE (PSF) OUTSWING	
				POSITIVE	NEGATIVE	POSITIVE	NEGATIVE
X	37.25" x 86.0"	N/A	N/A	+55.0	-60.0	+55.0	-55.0
OX / XO	76.0" x 86.0"	21.0" x 62.5"	G1	+45.0	-45.0	+45.0	-45.0
OXO	114.75" x 86.0"	21.0" x 62.5"		+45.0	-45.0	+45.0	-45.0

PRODUCT:	PLASTPRO FIBERGLASS DOOR
PART OR ASSEMBLY:	TYPICAL ELEVATIONS, DESIGN PRESSURES & GENERAL NOTES
DATE:	3/25/10
SCALE:	N.T.S.
DWG. BY:	JK
CHK. BY:	LFS
DRAWING NO.:	TX-4062
SHEET	1 OF 10

R:\Clients\Plastpro, Inc PERMANENT\B - TD\Hinged Doors - Fiberglass\DR - 442 Opaque Fiberglass (Non-Impact)\C - Drawings\TX-4062-4063.dwg, 1-2

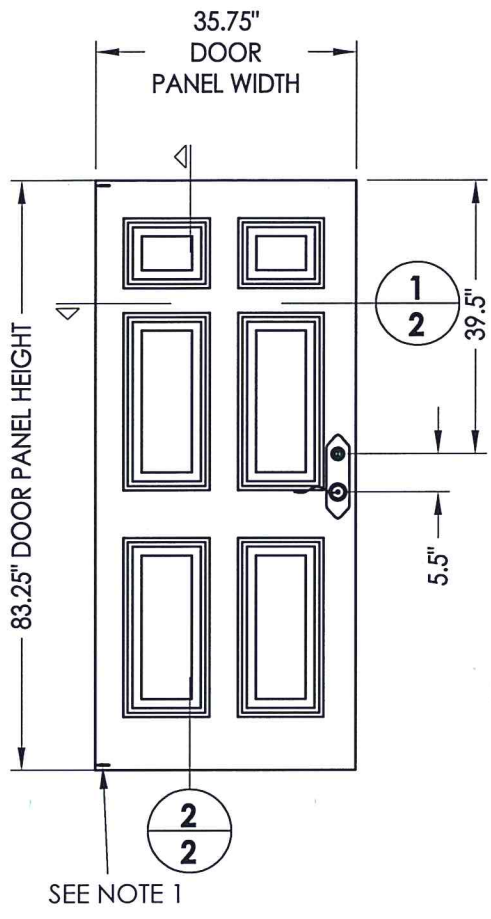

40 DOOR PANEL

FIBERGLASS DOOR SKIN: MIN. 0.075\"/>

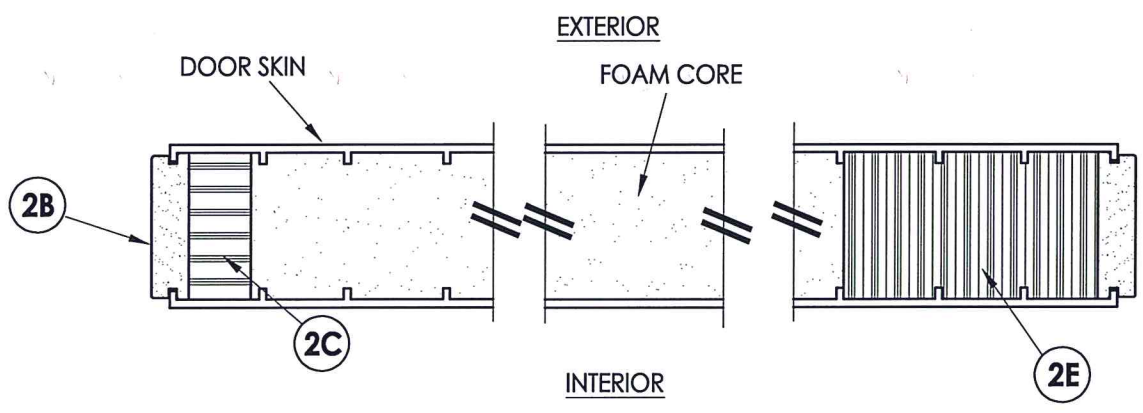

1 HORIZONTAL CROSS SECTION

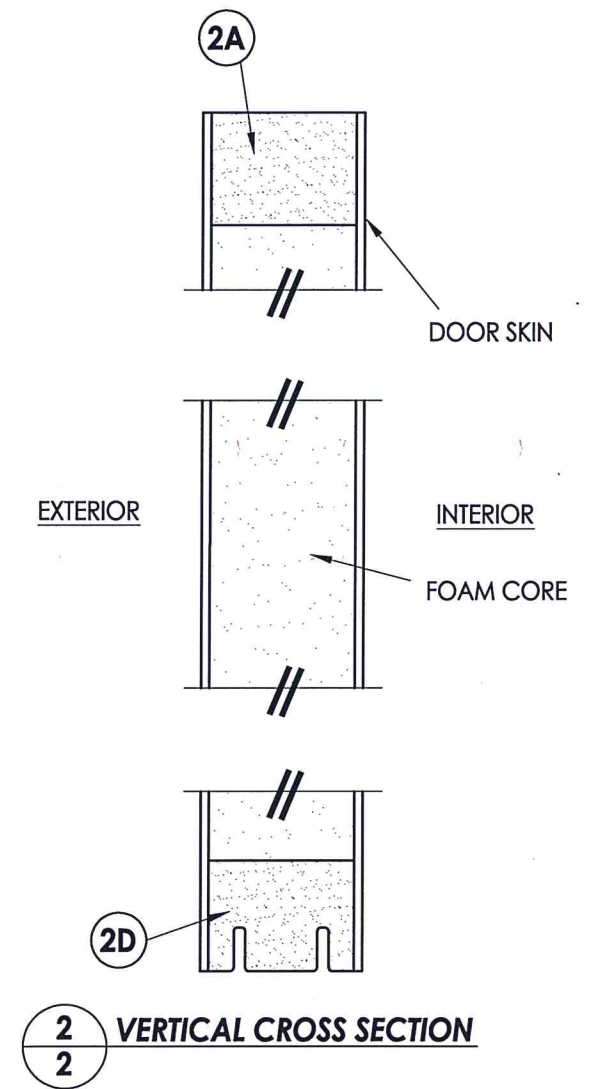
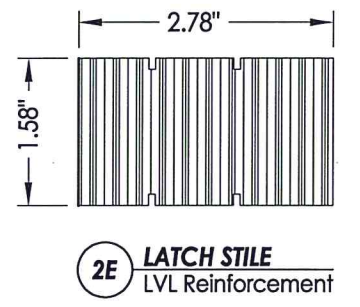
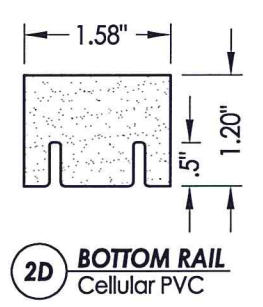
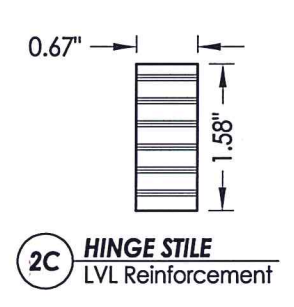
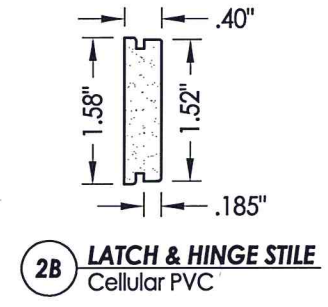
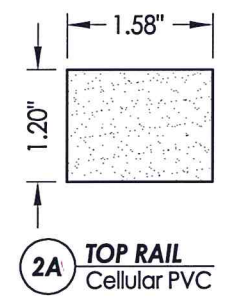

2 VERTICAL CROSS SECTION



S.27.20

Documents Prepared By: Lyndon F. Schmidt, P.E.
TEXAS P.E. #104123

RW BUILDING CONSULTANTS, INC.
P.O. Box 230 Valrico FL 33595
Phone No.: 813.669.9197
TEXAS BOARD OF PROFESSIONAL ENGINEERS
CERTIFICATE OF REGISTRATION # F-11852

PRODUCT: PLASTPRO FIBERGLASS DOOR	
PART OR ASSEMBLY: DOOR PANEL DETAILS	
NO.	DATE
1	5/21/20
LFS	BY
REVISIONS	
DATE: 3/25/10	
SCALE: N.T.S.	
DWG. BY: JK	
CHK. BY: LFS	
DRAWING NO.: TX-4062	
SHEET 2 OF 10	

NOTE 1:
1. #8 x 2\"/>

R:\Clients\Plastipro, Inc PERMANENT\B - TD\Hinged Doors - Fiberglass\DR - 442 Opaque Fiberglass (Non-Impact)\C - Drawings\TX-4062.4063.dwg, 1-3

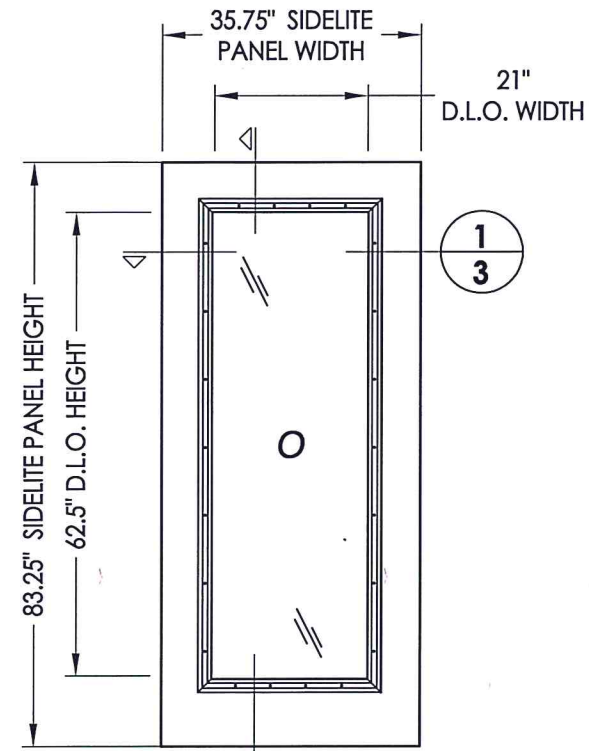

50 SIDELITE PANEL

FIBERGLASS SIDELITE SKIN: MIN. 0.075" THK.
CORE MATERIAL: POLYURETHANE FOAM (MIN. 1.9 PCF DENSITY)

NOTE:
1. Spacing for lite frame screws is as follows:
Sides: 6.5" from corners and 10.0" o.c. thereafter
Top & Bottom: 4.5" from corners and 6.5" o.c. thereafter

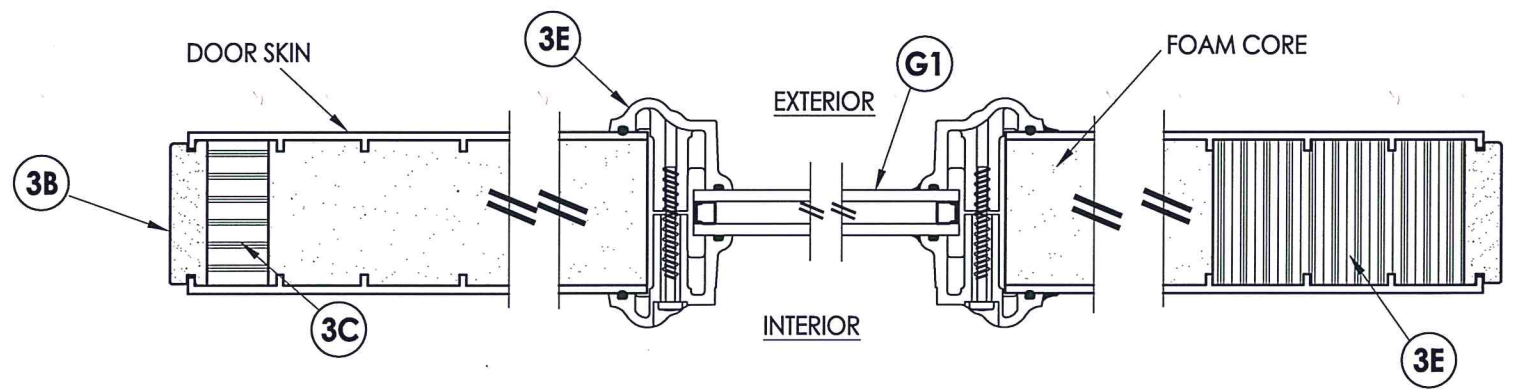

1 HORIZONTAL CROSS SECTION

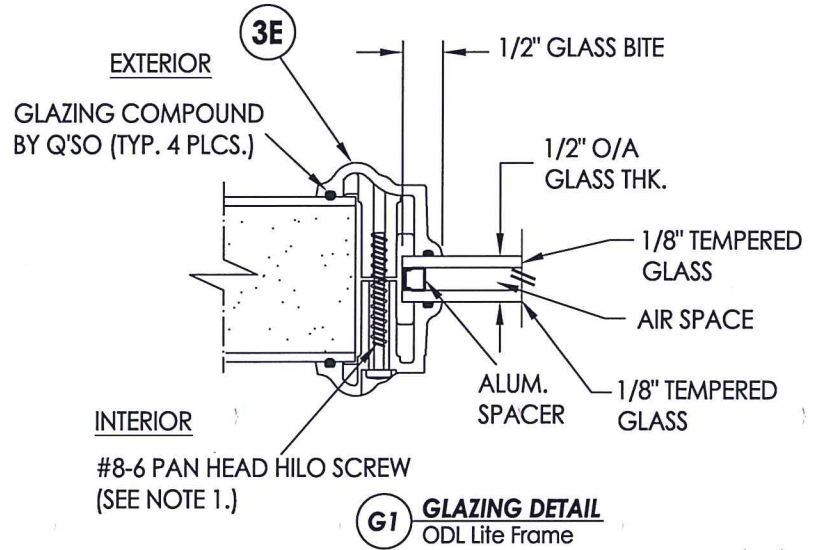

G1 GLAZING DETAIL
ODL Lite Frame

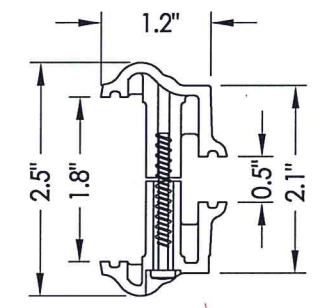

3E PLASTIC LIP LITE FRAME
ODL

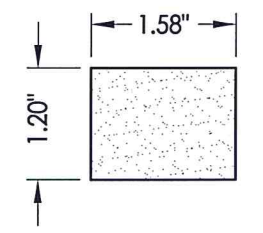

3A TOP RAIL
Cellular PVC

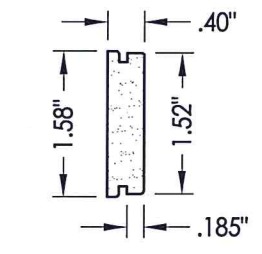

3B STILE
Cellular PVC

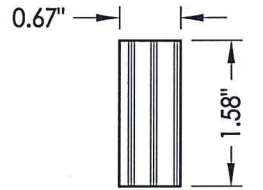

3C STILE
LVL Reinforcement

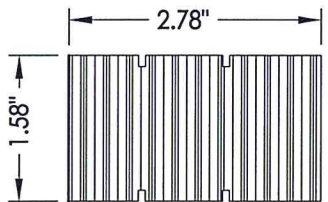

3E STILE
LVL Reinforcement

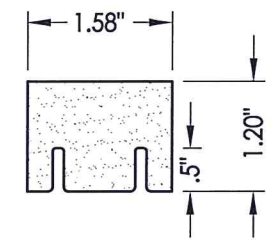

3D BOTTOM RAIL
Cellular PVC

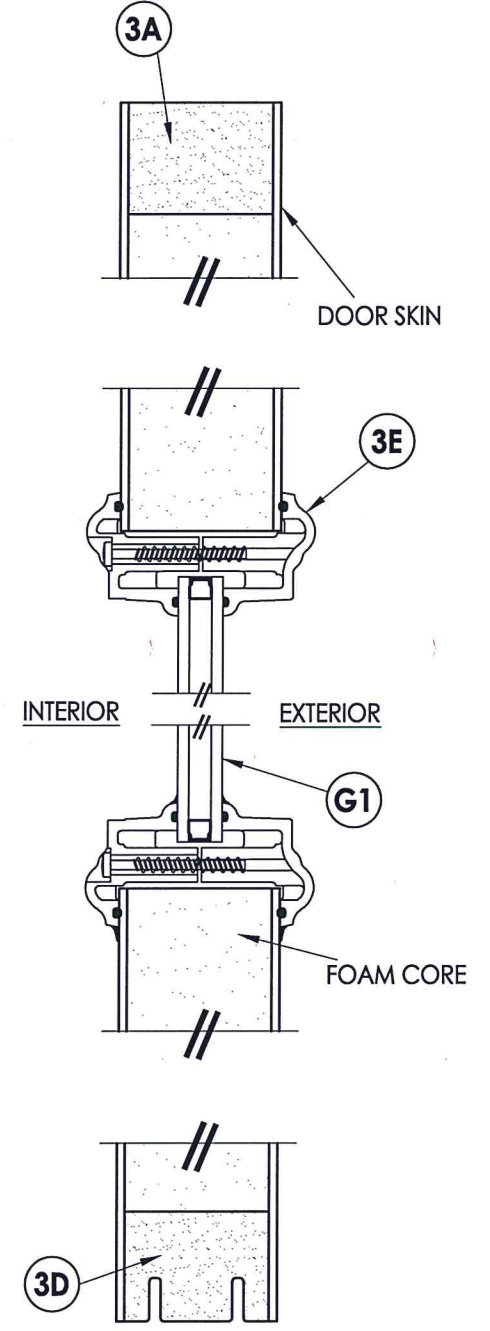

2 VERTICAL CROSS SECTION



Documents Prepared By: Lyndon F. Schmidt, P.E.
TEXAS P.E. #104123

RW BUILDING CONSULTANTS, INC.
P.O. Box 230 Valrico FL 33595
Phone No.: 813.659.9197

TEXAS BOARD OF PROFESSIONAL ENGINEERS
CERTIFICATE OF REGISTRATION # F-11852

PRODUCT: PLASTIPRO FIBERGLASS DOOR

PART OR ASSEMBLY: SIDELITE PANEL & GLAZING DETAILS

NO.	DATE	DESCRIPTION	BY
1	5/21/20	UPDATE TO 2018 IBC/IRC CODE	LFS

DATE: 3/25/10
SCALE: N.T.S.
DWG. BY: JK
CHK. BY: LFS
DRAWING NO.: TX-4062
SHEET 3 OF 10

R:\Clients\Plastpro, Inc. PERMANENT\B - TD\Hinged Doors - Fiberglass\DR - 442 Opaque Fiberglass (Non-Impact)\C - Drawings\TX-4062.4063.dwg, 1-4

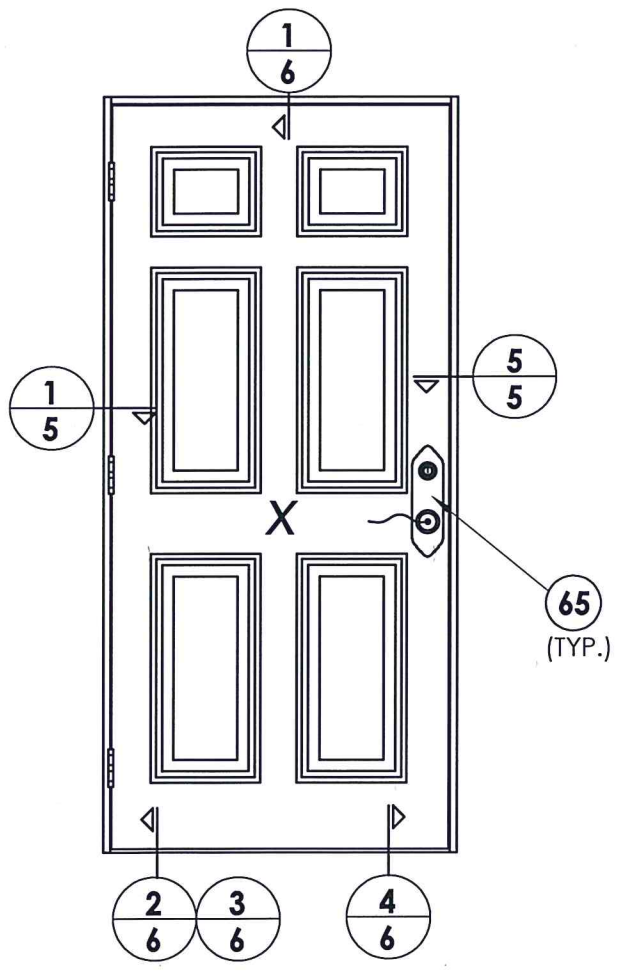

ELEVATION (X)

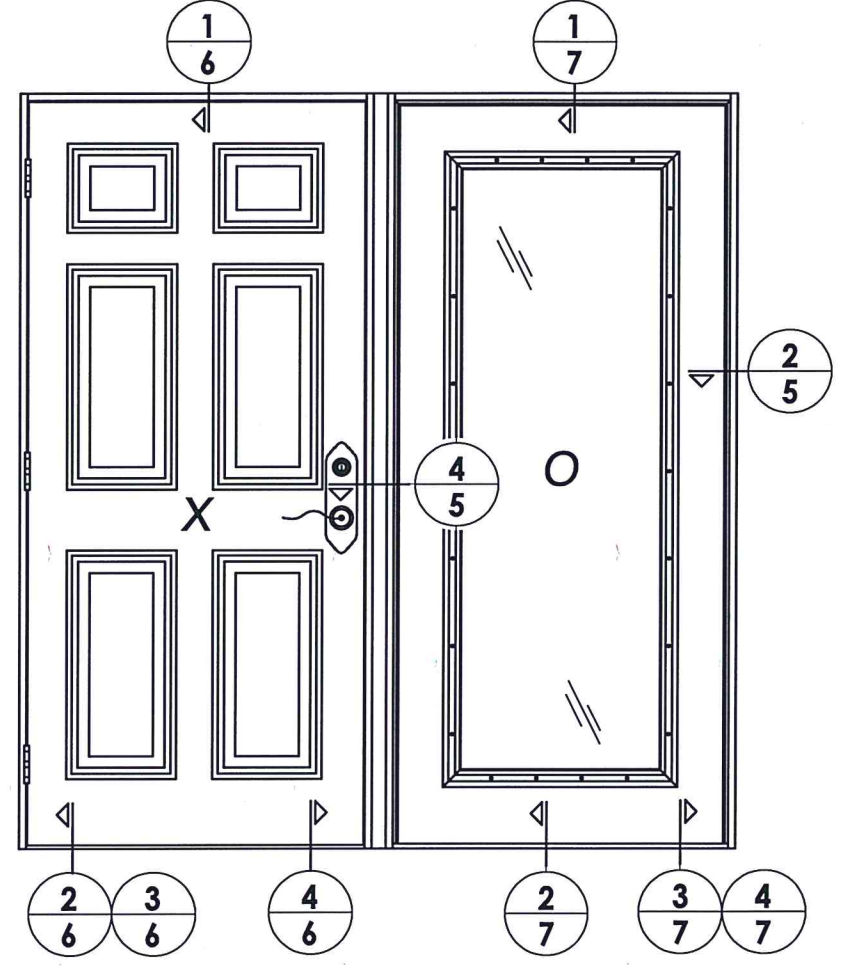

ELEVATION (XO / OX)

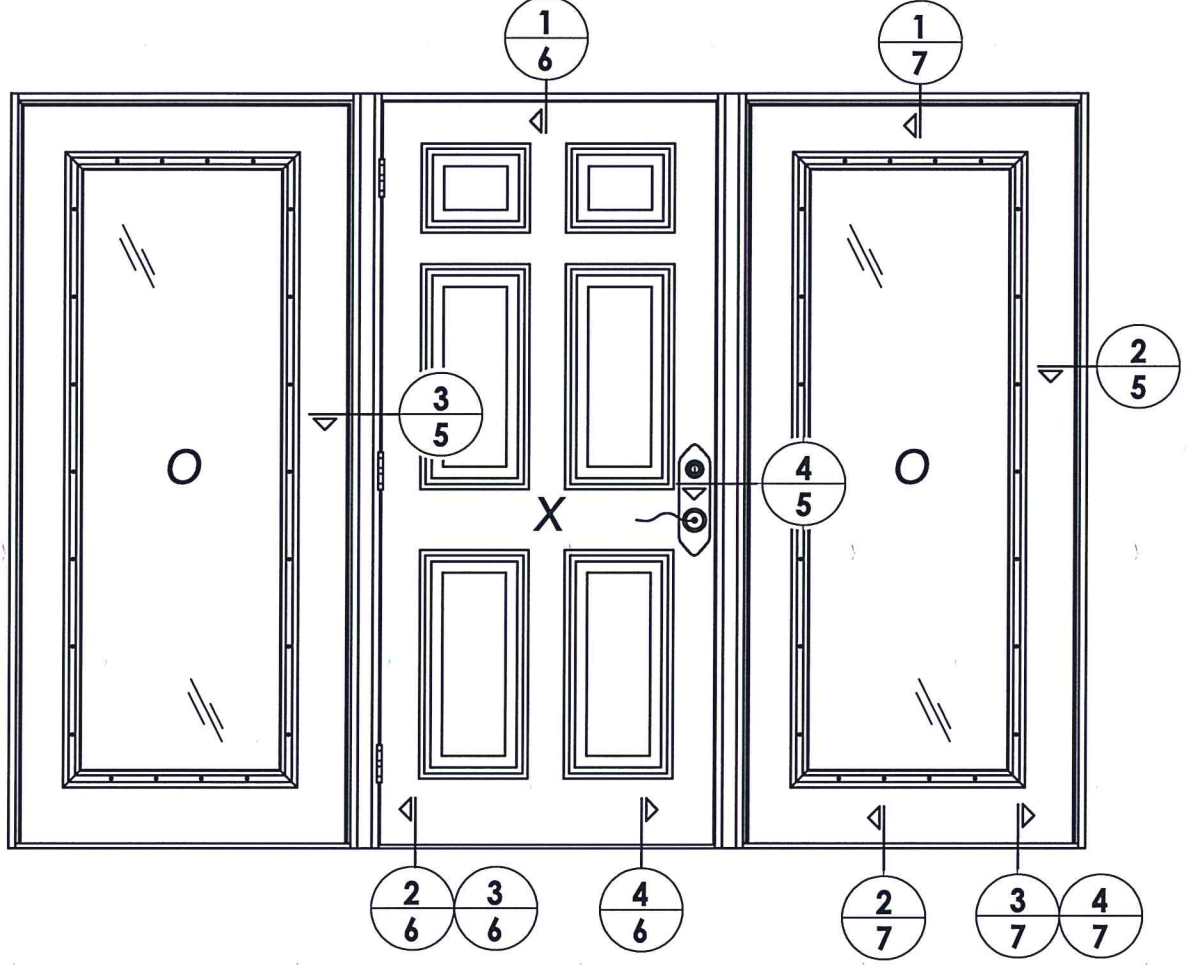

ELEVATION (OXO)

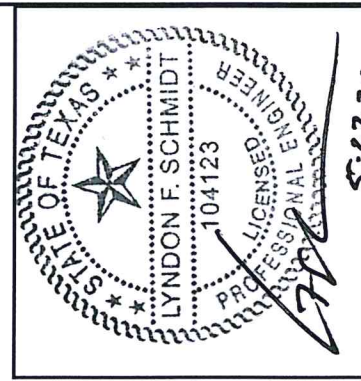

Documents Prepared By: Lyndon F. Schmidt, P.E.
 TEXAS P.E. #104123

RW BUILDING CONSULTANTS, INC.
 P.O. Box 230 Valrico FL 33595
 Phone No.: 813.659.9197

TEXAS BOARD OF PROFESSIONAL ENGINEERS
 CERTIFICATE OF REGISTRATION # F-11852

PRODUCT: PLASTPRO FIBERGLASS DOOR

PART OR ASSEMBLY: ELEVATIONS

NO.	DATE	DESCRIPTION	BY
1	5/21/20	UPDATE TO 2018 IBC/IRC CODE	LFS

DATE: 3/25/10

SCALE: N.T.S.

DWG. BY: JK

CHK. BY: LFS

DRAWING NO.: TX-4062

SHEET 4 of 10

R:\Clients\Plastpro, Inc PERMANENT\B - TD\Hinged Doors - Fiberglass\DR - 442 Opaque Fiberglass (Non-Impact)\C - Drawings\TX-4062.4063.dwg, 1-5

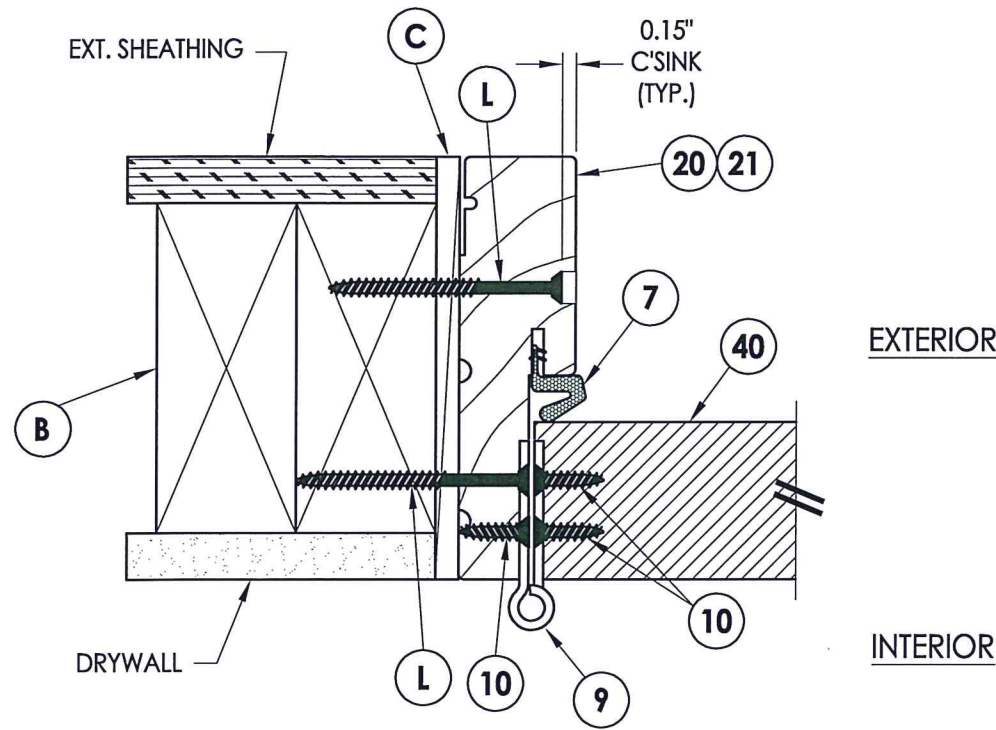

1 **HORIZONTAL CROSS SECTION**
5 Inswing shown - outswing also approved

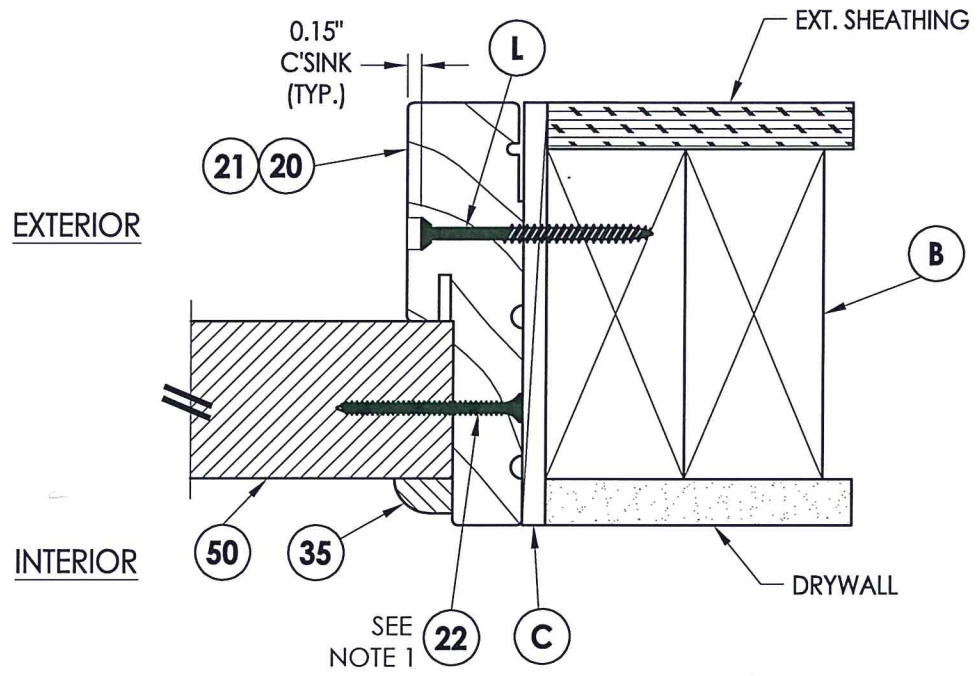

2 **HORIZONTAL CROSS SECTION**
5 Inswing shown - outswing also approved



NOTE:
 1. Sidelite screws (item #22) located at 3", 6", 16", 27", 38", 49", 60", 70" and 80" from bottom of panel.

Documents Prepared By: Lyndon F. Schmidt, P.E.
 TEXAS P.E. #104123
RW BUILDING CONSULTANTS, INC.
 P.O. Box 230 Valrico FL, 33595
 Phone No.: 813.659.9197
 TEXAS BOARD OF PROFESSIONAL ENGINEERS
 CERTIFICATE OF REGISTRATION # F-11852

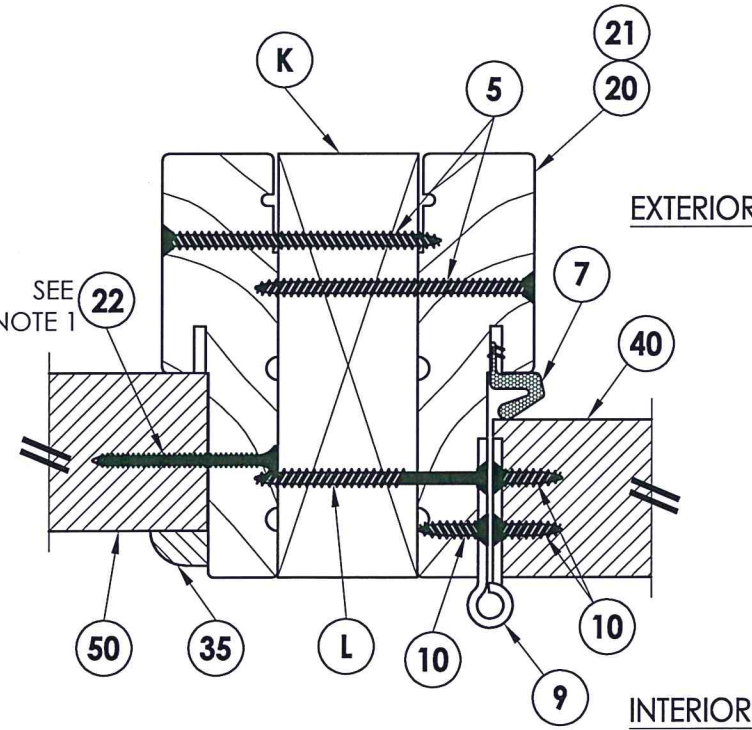

3 **HORIZONTAL CROSS SECTION**
5 Inswing shown - outswing also approved

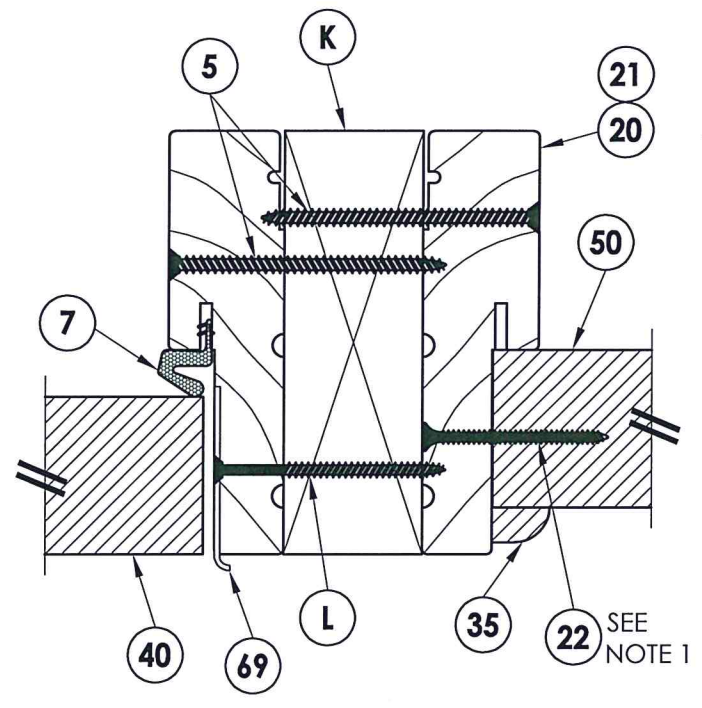

4 **HORIZONTAL CROSS SECTION**
5 Inswing shown - outswing also approved

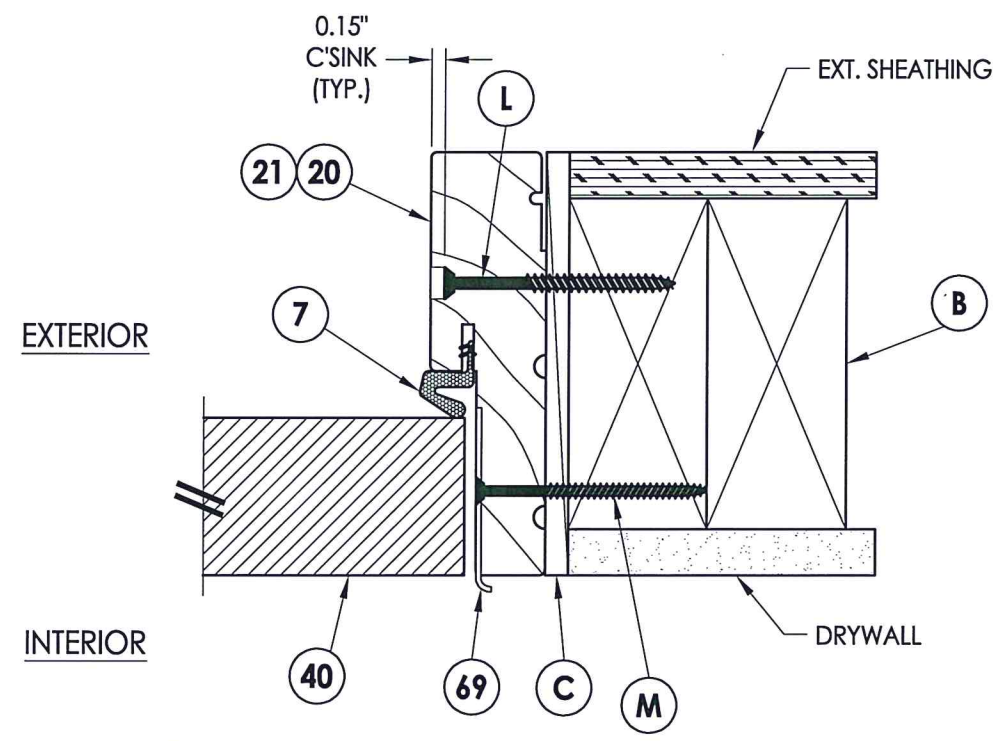

5 **HORIZONTAL CROSS SECTION**
5 Inswing shown - outswing also approved

PRODUCT:	PLASTPRO FIBERGLASS DOOR
PART OR ASSEMBLY:	HORIZONTAL CROSS SECTIONS
DATE:	3/25/10
SCALE:	N.T.S.
DWG. BY:	JK
CHK. BY:	LFS
DRAWING NO.:	TX-4062
SHEET	5 of 10
NO.	1
DATE	5/21/20
REVISIONS	UPDATE TO 2018 IBC/IRC CODE
BY	LFS

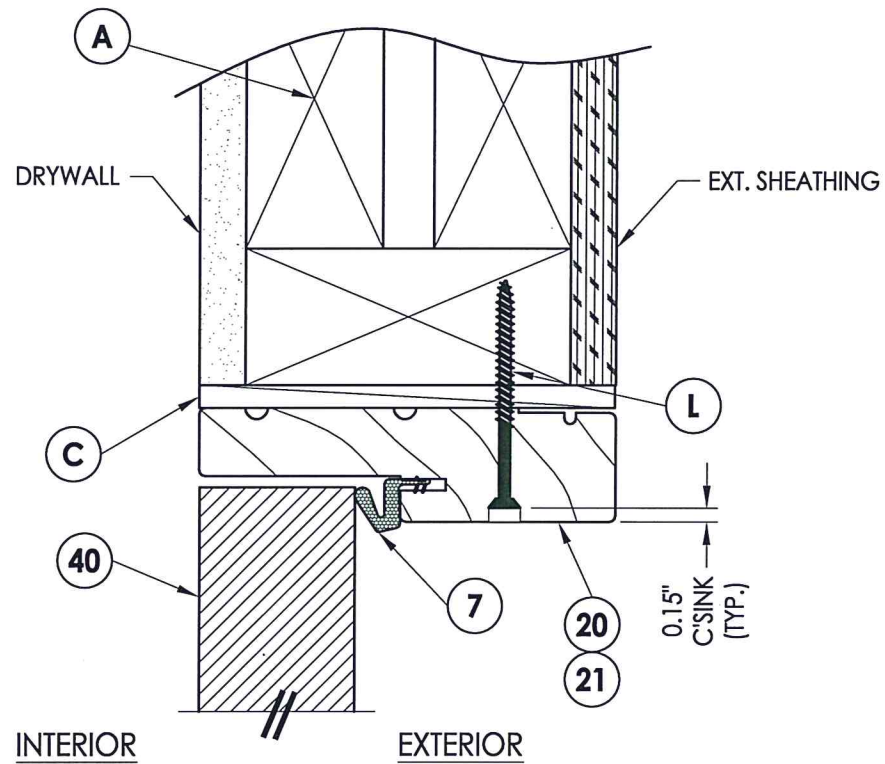

1 VERTICAL CROSS SECTION
6 Inswing shown - outswing also approved

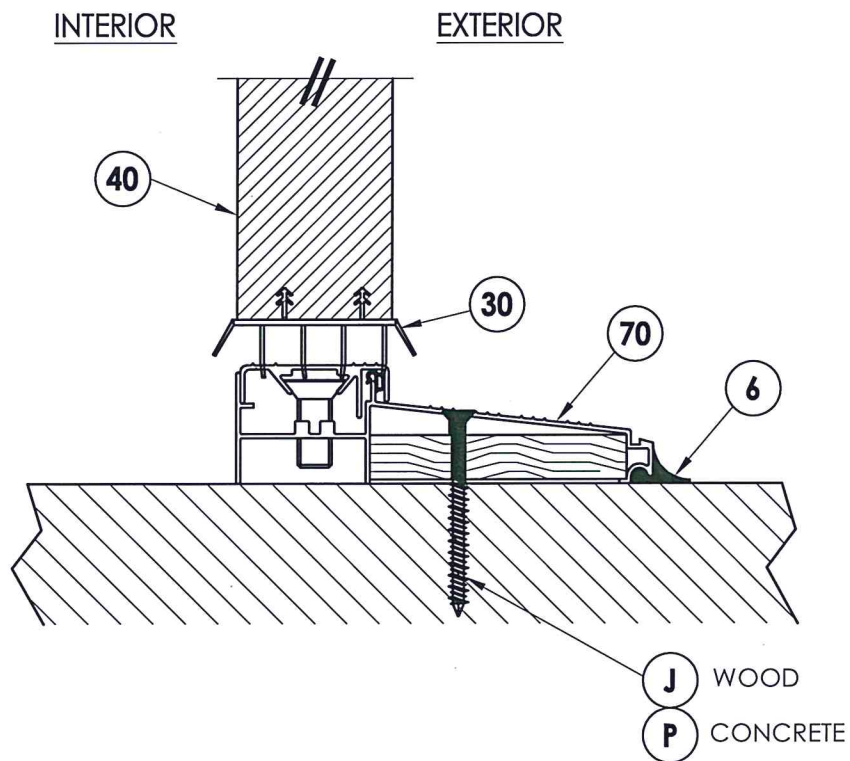

2 VERTICAL CROSS SECTION
6 Inswing configuration

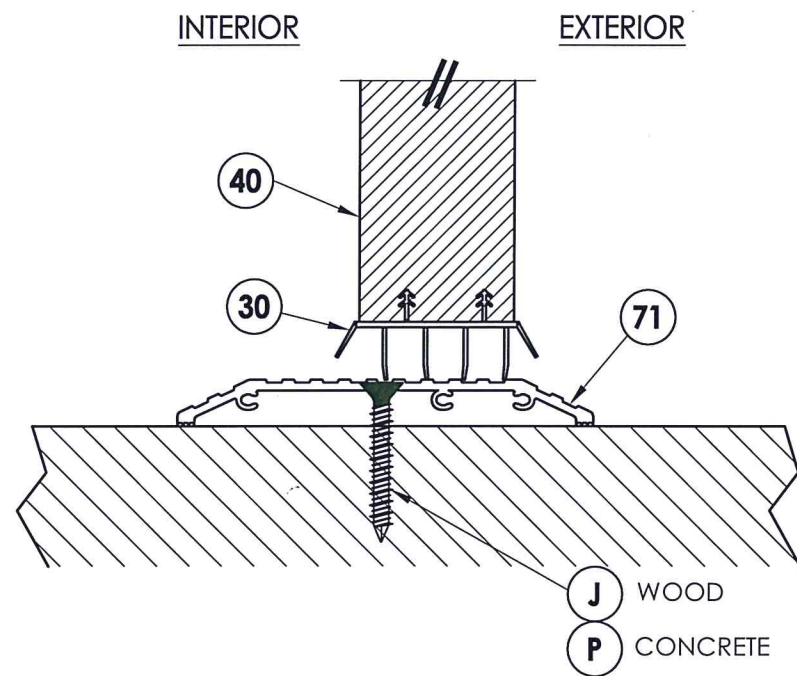

3 VERTICAL CROSS SECTION
6 Shown w/ ADA threshold

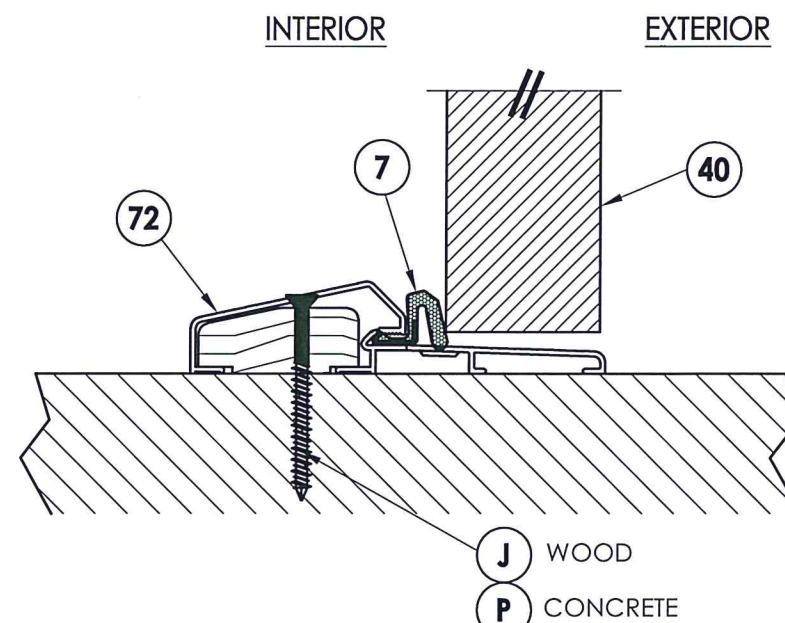

4 VERTICAL CROSS SECTION
6 Outswing configuration



Documents Prepared By: Lyndon F. Schmidt, P.E.
 TEXAS P.E. #104123

RW BUILDING CONSULTANTS, INC.
 P.O. Box 230 Valrico FL 33595
 Phone No.: 813.659.9197

TEXAS BOARD OF PROFESSIONAL ENGINEERS
 CERTIFICATE OF REGISTRATION # F-11852

PRODUCT:		PLASTPRO FIBERGLASS DOOR	
PART OR ASSEMBLY:		VERTICAL CROSS SECTIONS	
NO.	DATE	DESCRIPTION	BY
1	5/21/20	UPDATE TO 2018 IBC/IRC CODE	LFS
REVISIONS			
DATE: 3/25/10			
SCALE: N.T.S.			
DWG. BY: JK			
CHK. BY: LFS			
DRAWING NO.: TX-4062			
SHEET 6 OF 10			

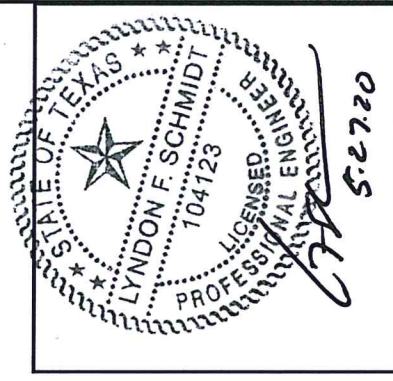

Documents Prepared By: Lyndon F. Schmidt, P.E.
TEXAS P.E. #104123

RW BUILDING CONSULTANTS, INC.
P.O. Box 230 Valrico FL, 33595
Phone No.: 813.659.9197

TEXAS BOARD OF PROFESSIONAL ENGINEERS
CERTIFICATE OF REGISTRATION # F-11852

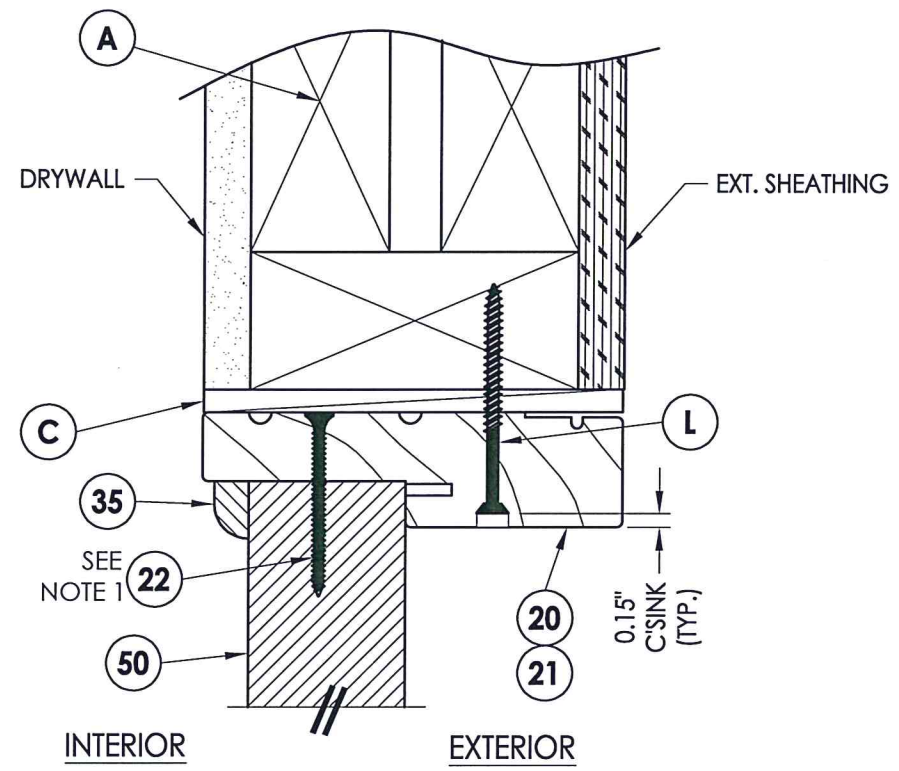

1 VERTICAL CROSS SECTION
7 Inswing shown - outswing also approved

NOTE:
1. Screws thru head and sill jamb located 3" from each end and on center line.

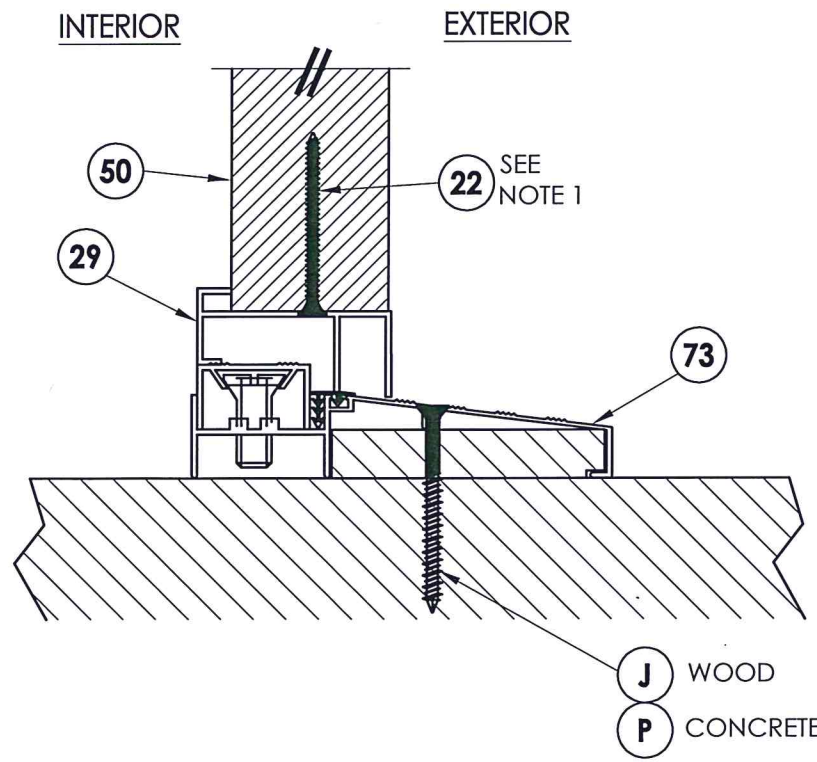

2 VERTICAL CROSS SECTION
7 Inswing configuration

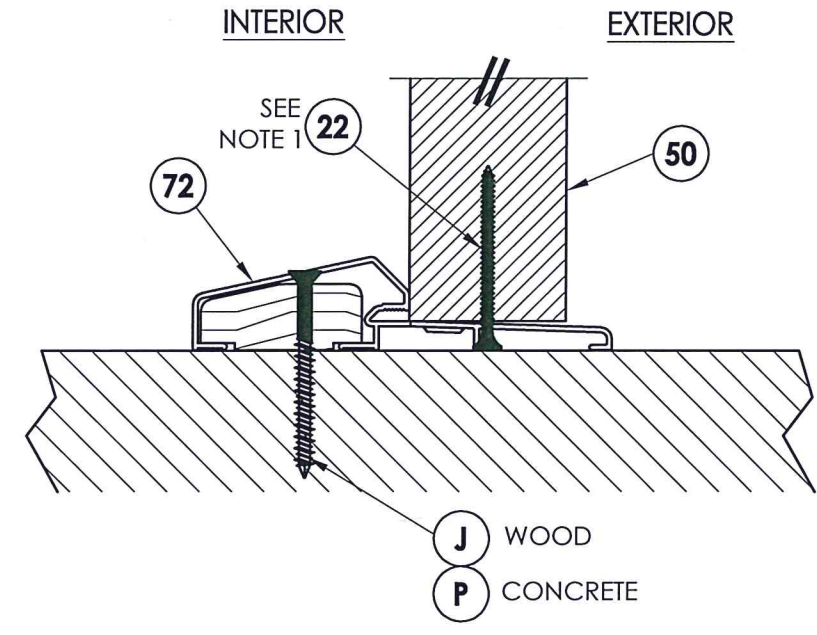

3 VERTICAL CROSS SECTION
7 Outswing configuration

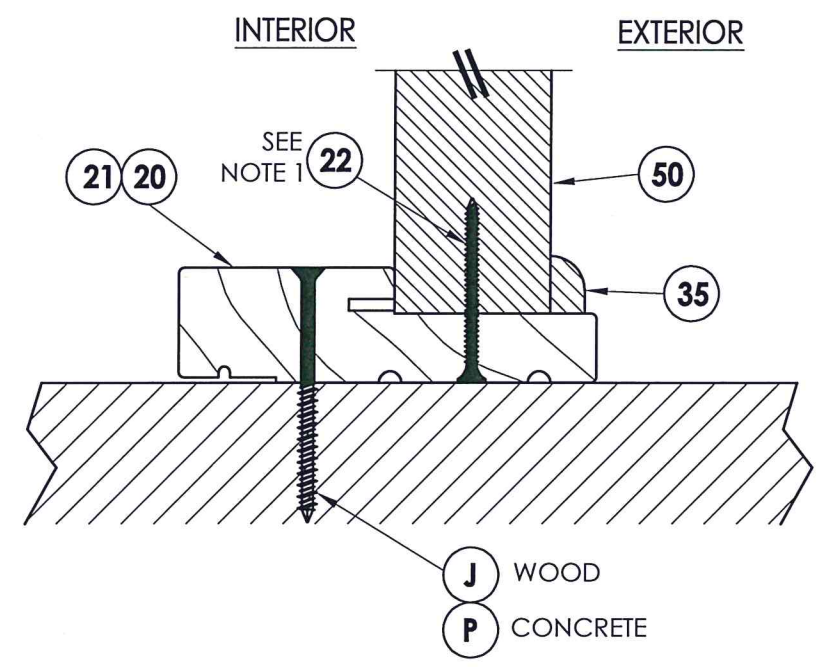

4 VERTICAL CROSS SECTION
7 Outswing configuration

PRODUCT: PLASTPRO FIBERGLASS DOOR		PART OR ASSEMBLY: VERTICAL CROSS SECTIONS	
NO.	DATE	LFS	BY
1	5/21/20	UPDATE TO 2018 IBC/IRC CODE	
REVISIONS			
DATE: 3/25/10			
SCALE: N.T.S.			
DWG. BY: JK			
CHK. BY: LFS			
DRAWING NO.: TX-4062			
SHEET 7 OF 10			

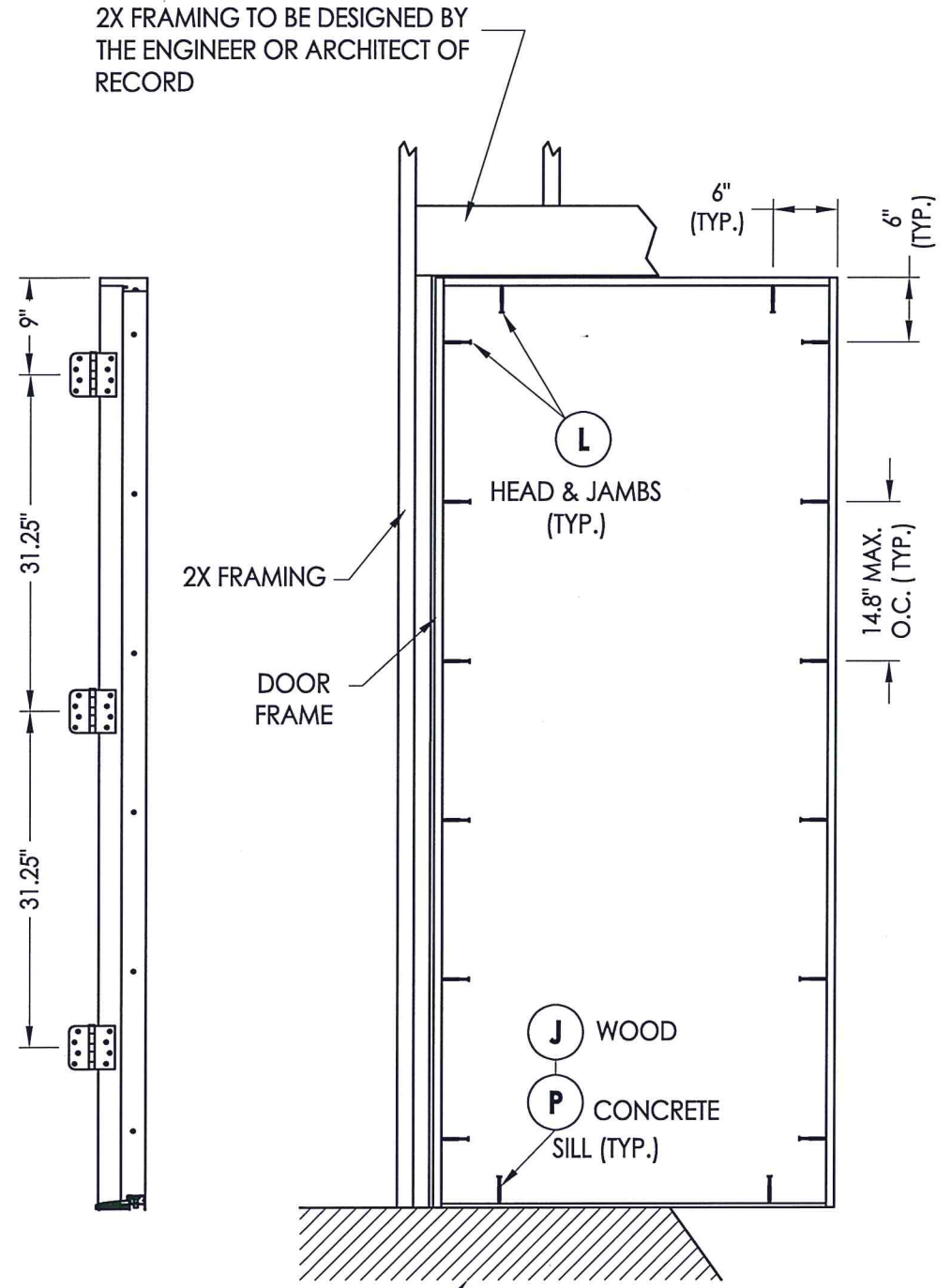

HINGE JAMB

FLOOR SUBSTRATE MATERIAL
 CONCRETE (MIN. 3000 PSI)
 WOOD (S.G. >= 0.42)

FRAME ANCHORING
 X

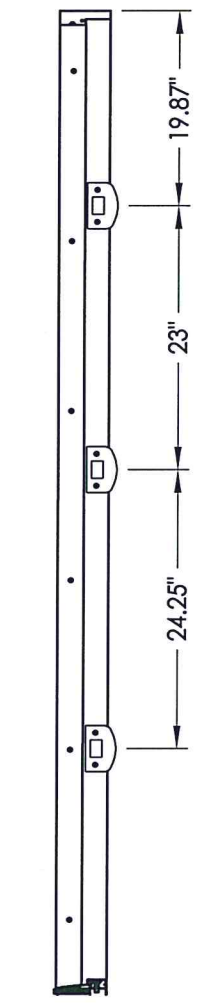

STRIKE JAMB

FLOOR SUBSTRATE MATERIAL
 CONCRETE (MIN. 3000 PSI)
 WOOD (S.G. >= 0.42)

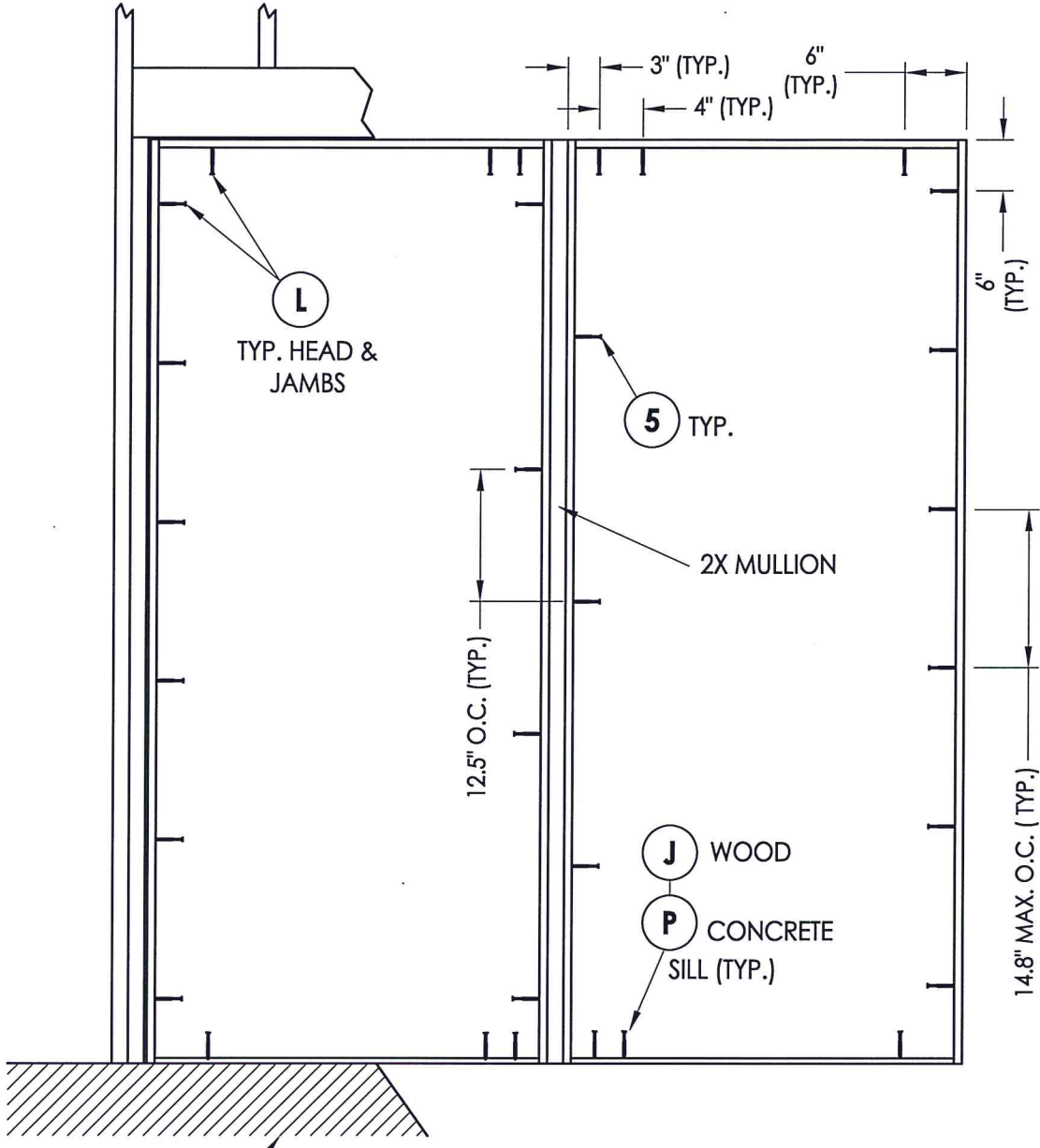

FRAME ANCHORING
 XO / OX

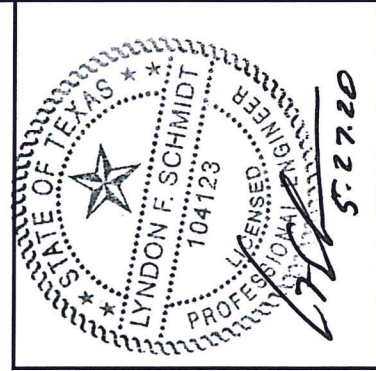
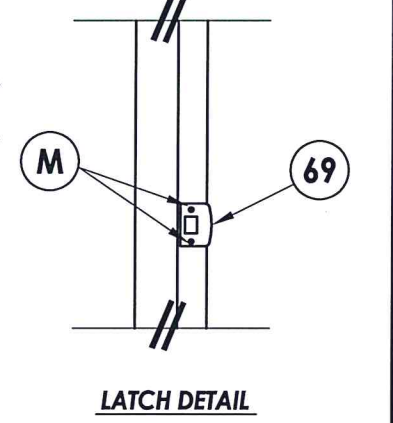
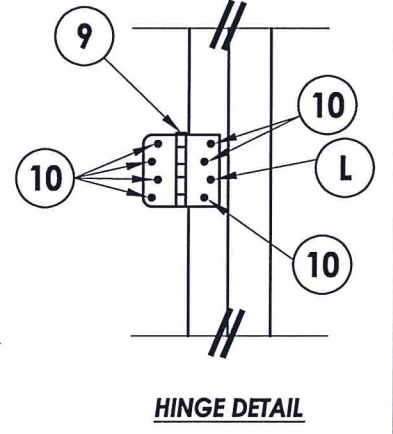

Documents Prepared By: Lyndon F. Schmidt, P.E.
 TEXAS P.E. #104123

RW BUILDING CONSULTANTS, INC.
 P.O. Box 230 Valrico FL 33595
 Phone No.: 813.659.9197

TEXAS BOARD OF PROFESSIONAL ENGINEERS
 CERTIFICATE OF REGISTRATION # F-11852

PRODUCT: PLASTPRO FIBERGLASS DOOR

PART OR ASSEMBLY: FRAME ANCHORING

NO.	DATE	DESCRIPTION	BY
1	5/21/20	UPDATE TO 2018 IBC/IRC CODE	LFS

DATE: 3/25/10
 SCALE: N.T.S.
 DWG. BY: JK
 CHK. BY: LFS
 DRAWING NO.: TX-4062
 SHEET 8 OF 10

R:\Clients\Plastpro, Inc PERMANENT\B - TD\Hinged Doors - Fiberglass\DR - 442 Opaque Fiberglass (Non-Impact)\C - Drawings\TX-4062.4063.dwg, 1-9

2X FRAMING TO BE DESIGNED BY THE ENGINEER OR ARCHITECT OF RECORD

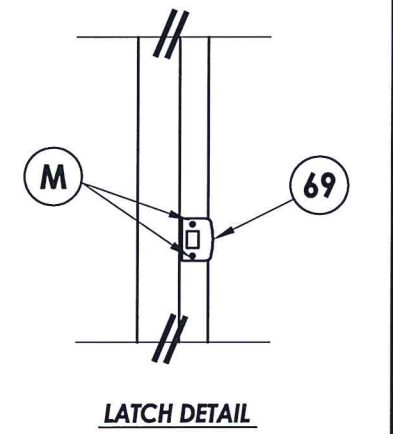
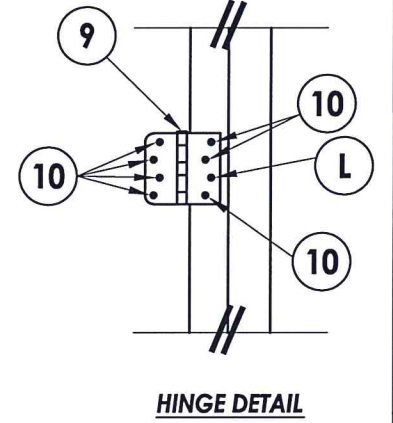
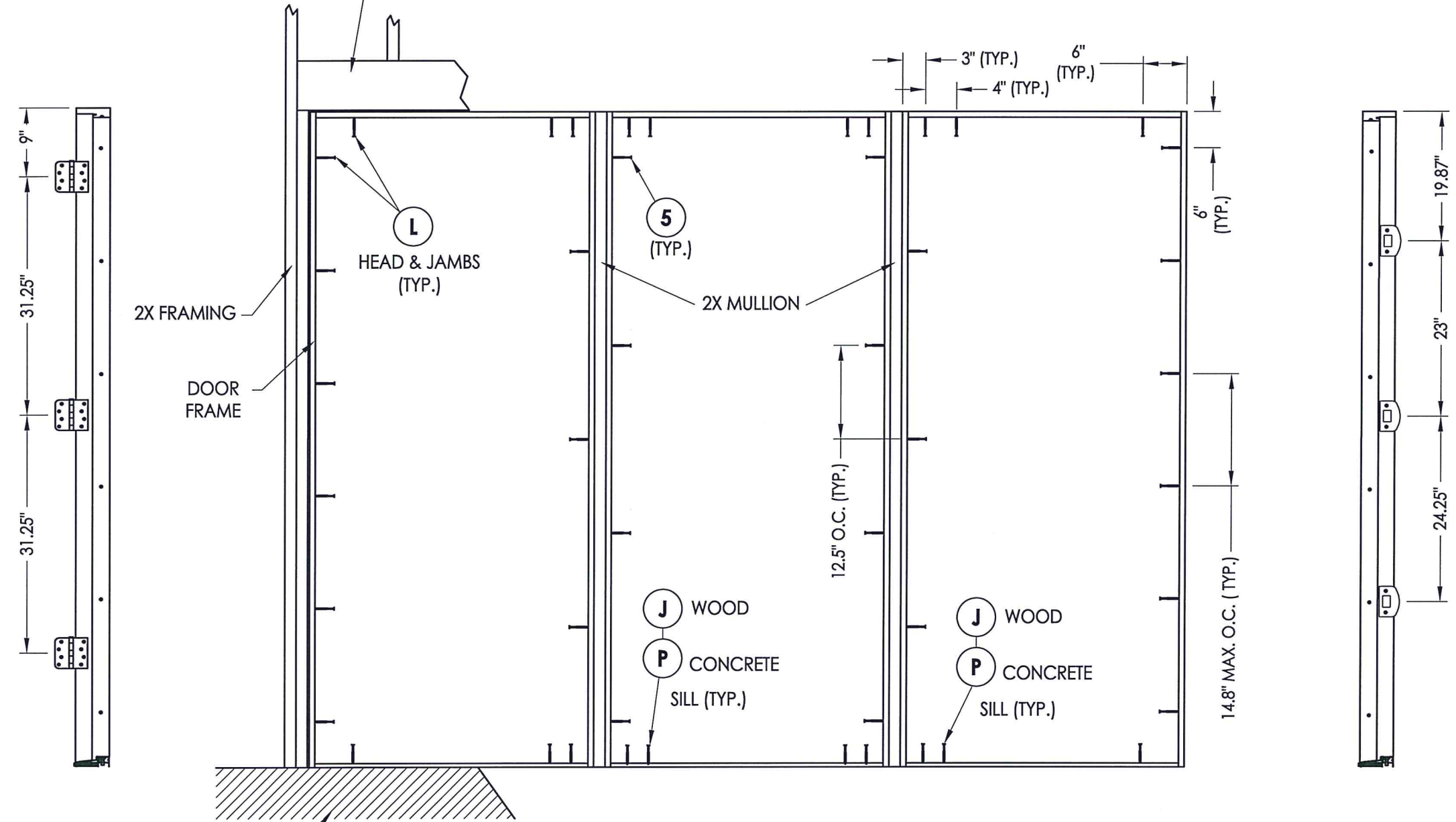

HINGE JAMB
FLOOR SUBSTRATE MATERIAL
CONCRETE (MIN. 3000 PSI)
WOOD (S.G. >= 0.42)

FRAME ANCHORING
OXO

STRIKE JAMB



Documents Prepared By: Lyndon F. Schmidt, P.E.
TEXAS P.E. #104123

RW BUILDING CONSULTANTS, INC.
P.O. Box 230 Valrico FL 33595
Phone No.: 813.659.9197

TEXAS BOARD OF PROFESSIONAL ENGINEERS
CERTIFICATE OF REGISTRATION # F-11852

PRODUCT: PLASTPRO FIBERGLASS DOOR

PART OR ASSEMBLY: FRAME ANCHORING

NO.	DATE	DESCRIPTION	BY
1	5/21/20	UPDATE TO 2018 IBC/IRC CODE	LFS

DATE: 3/25/10
SCALE: N.T.S.
DWG. BY: JK
CHK. BY: LFS
DRAWING NO.: TX-4062
SHEET 9 of 10

© 2010 R.W. BUILDING CONSULTANTS INC.

R:\Clients\Plastpro, Inc PERMANENT\B - TD\Hinged Doors - Fiberglass\DR - 442 Opaque Fiberglass (Non-Impact)\C - Drawings\TX-4062.4063.dwg, 1-10

BILL OF MATERIALS		
ITEM	DESCRIPTION	MATERIAL
A	2X HEADER FRAMING SG >= 0.42	WOOD
B	2X FRAMING SG >= 0.42	WOOD
C	1/4" MAX. SHIM SPACE	-
J	#10 X 3" PFH WOOD SCREW	STEEL
P	1/4" PFH ELCO OR ITW CONCRETE SCREW (1-3/4" MIN. EMB.)	STEEL
K	2X REINFORCEMENT (CLEAR PINE SG >= 0.42)	WOOD
L	#10 X 2-1/2" PFH WOOD SCREW (1.15" MIN. EMBEDMENT)	STEEL
M	#8 X 2-1/2" PFH WOOD SCREW	STEEL
5	#10 X 3" PFH SCREW	STEEL
6	SEALANT	SILICONE
7	WEATHERSTRIP BY Q-LON	FOAM
9	4" HINGE	STEEL
10	#9 X 3/4" PFH WOOD SCREW	STEEL
20	JAMB FINGER - JOINT - PINE (SG >= 0.42)	WOOD
21	POLY FIBER JAMB	POLY FIBER
22	#7 X 2" PFH DRYWALL SCREW	STEEL
29	SIDELITE SPACER	PVC
30	DOOR SWEEP	ALUM.
35	TRIM	WOOD
40	DOOR PANEL - SEE DOOR PANEL DETAIL SHEET FOR CONSTRUCTION DETAILS	-
50	SIDELITE PANEL - SEE SIDELITE PANEL DETAIL SHEET FOR CONSTRUCTION DETAILS	-
65	MULTI-POINT LOCK ASSEMBLY TRILENNIUM BY W & F	-
66	#10 X 1-1/2" PFH SCREW	STEEL
69	MULTI-POINT STRIKE PLATE	STEEL
70	INSWING THRESHOLD BY DLP	ALUM. / WOOD
71	ADA THRESHOLD BY DLP	ALUM.
72	OUTSWING THRESHOLD BY DLP	ALUM. / WOOD
73	SIDELITE THRESHOLD BY DLP	ALUM. / WOOD

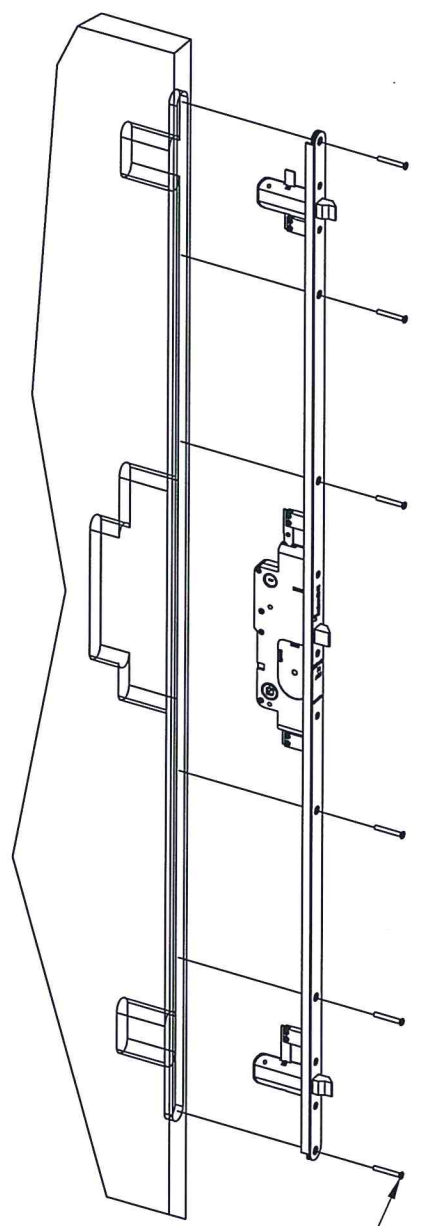
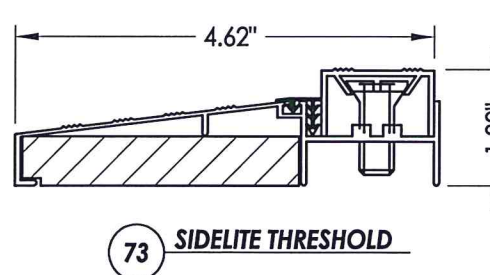
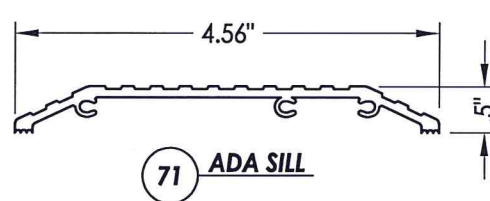
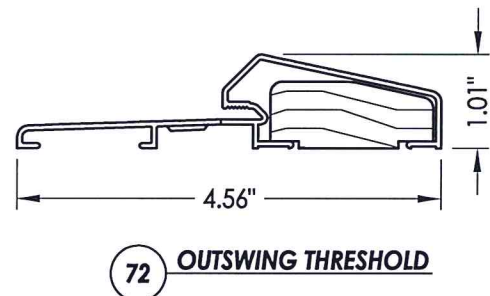
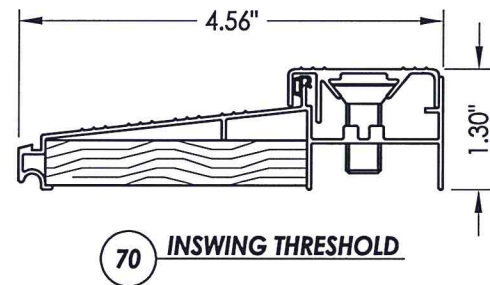
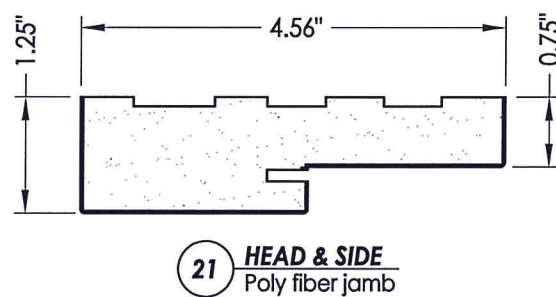
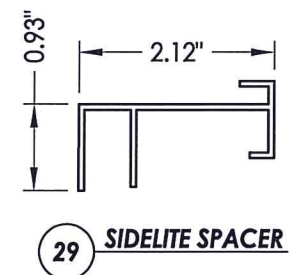
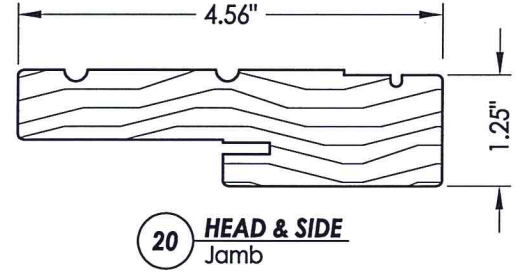

66 MULTI-POINT LOCK Trilennium by Endura

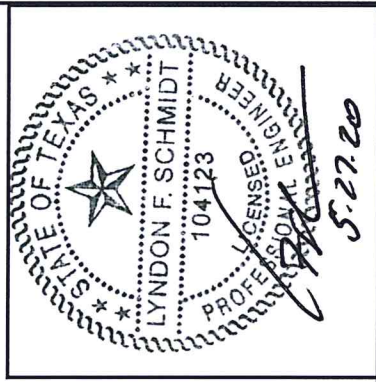

Documents Prepared By: Lyndon F. Schmidt, P.E.
TEXAS P.E. #104123

RW BUILDING CONSULTANTS, INC.
P.O. Box 230 Valrico FL 33595
Phone No.: 813.659.9197

TEXAS BOARD OF PROFESSIONAL ENGINEERS
CERTIFICATE OF REGISTRATION # F-11852

PRODUCT: PLASTPRO FIBERGLASS DOOR

PART OR ASSEMBLY: COMPONENTS, MULTI-POINT LOCK DETAILS & B.O.M.

NO.	DATE	REVISIONS
1	5/21/20	UPDATE TO 2018 IBC/IRC CODE
		LFS
		BY

DATE: 3/25/10
SCALE: N.T.S.
DWG. BY: JK
CHK. BY: LFS
DRAWING NO.: TX-4062
SHEET 10 OF 10

CONCRETE ANCHOR NOTES:

1. Substitution of equal concrete anchors from a different supplier may have different edge distance and center distance requirements.
2. Concrete anchor locations at the corners may be adjusted to maintain the min. edge distance to mortar joints. If concrete anchor locations noted as "MAX. ON CENTER" must be adjusted to maintain the min. edge distance to mortar joints, additional concrete anchors may be required to ensure the "MAX. ON CENTER" dimensions are not exceeded.
3. Concrete anchor table:

ANCHOR TYPE	ANCHOR SIZE	MIN. EMBEDMENT	MIN. CLEARANCE TO MASONRY EDGE	MIN. CLEARANCE TO ADJACENT ANCHOR
ITW	1/4"	1-3/4"	2-1/2"	3"
ELCO	1/4"	1-3/4"	1"	4"