

STEVE'S AND SONS

203 Humble Ave.
San Antonio, TX 78225

Opaque Fiberglass Single Door w/ or w/out Sidelites INSWING / OUTSWING "IMPACT"

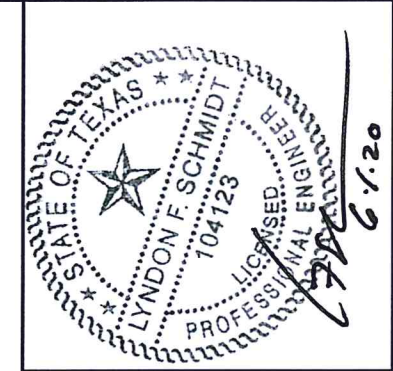
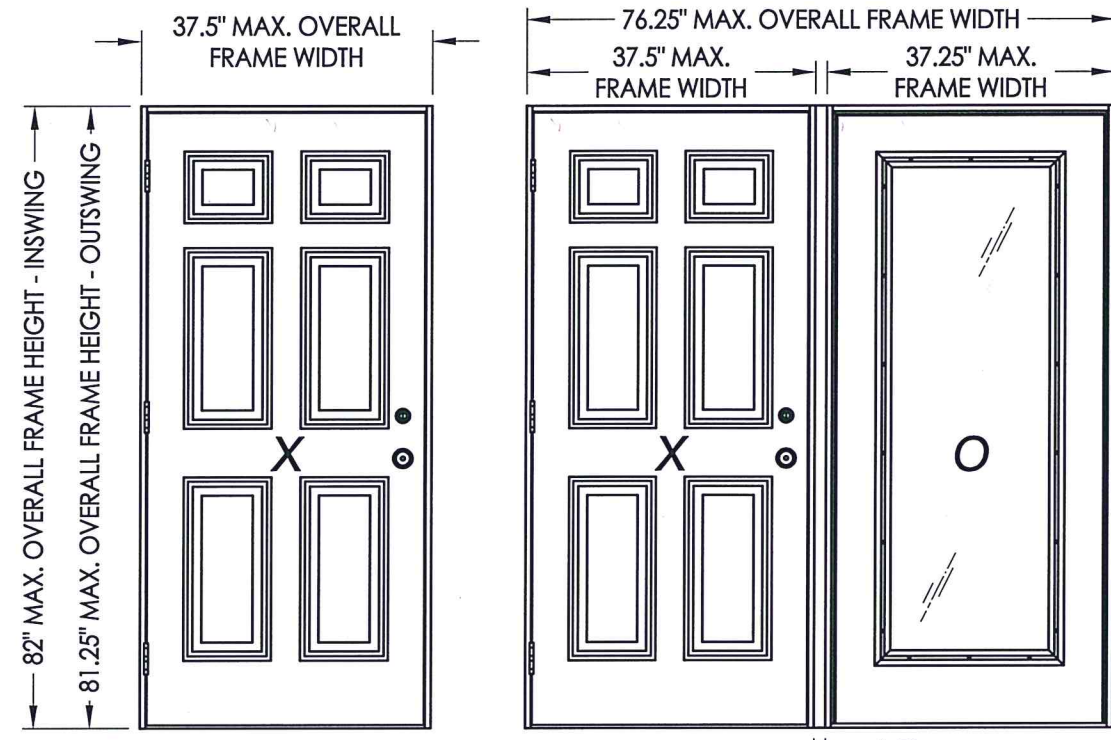

Documents Prepared By: Lyndon F. Schmidt, P.E.
TEXAS P.E. #104123

RW BUILDING CONSULTANTS, INC.
P.O. Box 230 Valrico FL, 33595
Phone No.: 813.659.9197

TEXAS BOARD OF PROFESSIONAL ENGINEERS
CERTIFICATE OF REGISTRATION # F-11852

EVALUATED FOR USE IN THE STATE OF TEXAS

The Fiberglass Door system described herein complies with the 2018 International Residential Code (IRC), Sections R301 & R609 and the 2018 International Building Code (IBC), Sections 1404.13, 1609, 1709.5, 2403 and 2404 subject to the following conditions:

1. Anchors shall be as listed and spaced as shown in the details. Anchor embedment to base material shall be beyond wall dressing or stucco.
2. This system has been tested and evaluated as a large missile impact protective system for installation in areas that require wind borne debris protection. This product meets missile level "D" as defined in ASTM E 1996.
3. Allowable design pressure requirements must be equal to or less than the design pressure rating shown in the design pressure chart, sheet 1 of this drawing.
4. Conditions not covered by this drawing are subject to further engineering analysis.

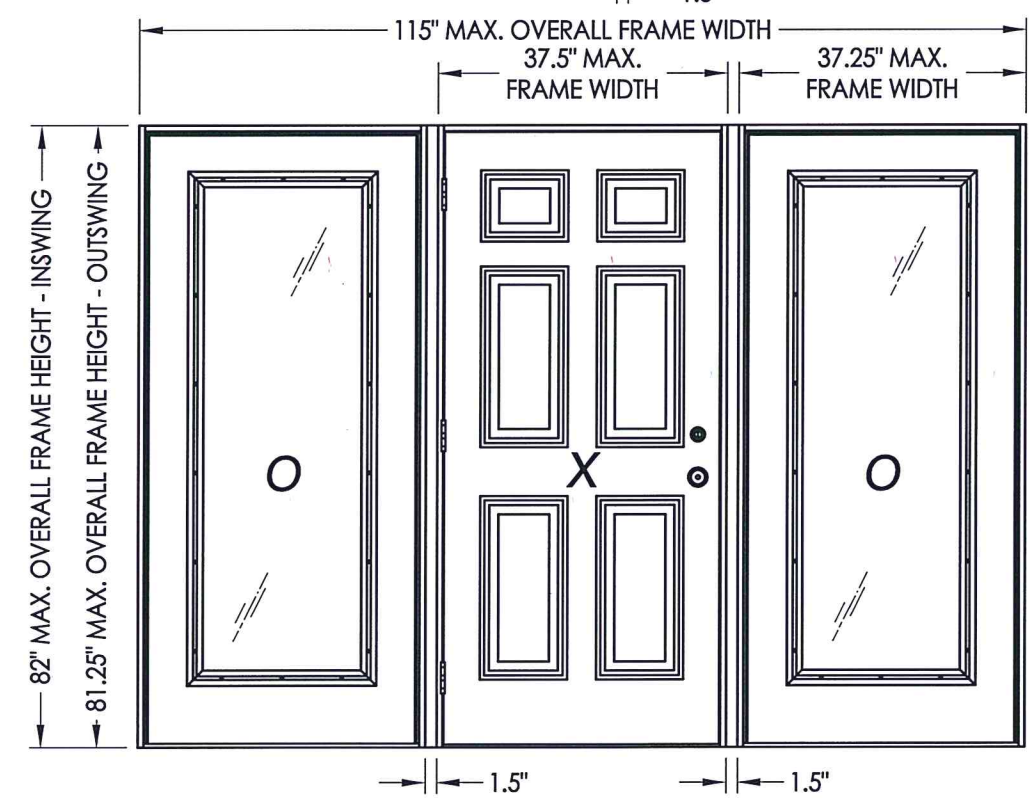

CONFIGURATION	MAX. FRAME DIMENSION	MAX. SIDELITE D.L.O. DIMENSION	GLASS TYPE	DESIGN PRESSURE (PSF) INSWING		DESIGN PRESSURE (PSF) OUTSWING	
				POSITIVE	NEGATIVE	POSITIVE	NEGATIVE
X	37.5" x 82.0"	N/A	N/A	+55.0	-60.0	+55.0	-55.0
OX / XO	76.25" x 82.0"	20.63" x 62.75"	G1, G2	+55.0	-60.0	+55.0	-55.0
OXO	115.0" x 82.0"	20.63" x 62.75"		+55.0	-60.0	+55.0	-55.0

TABLE OF CONTENTS	
SHEET #	DESCRIPTION
1	Typical elevations, design pressures & general notes
2	Door panel details
3	Sidelite panel & glazing details
4	Elevations
5	Horizontal cross sections
6	Vertical cross sections
7	Vertical cross sections
8	Frame anchoring
9	Frame anchoring
10	Components and bill of materials

PRODUCT: STEVE'S AND SONS FIBERGLASS DOOR	
PART OR ASSEMBLY: TYPICAL ELEVATIONS, DESIGN PRESSURES & GENERAL NOTES	
2	5/28/20 UPDATE TO 2018 IBC/IRC CODE AND REVISE IMPACT LITE FRAME
1	7/21/15 Manuf./Product Name Change
NO.	DATE
REVISIONS	
DATE: 04/13/10	
SCALE: N.T.S.	
DWG. BY: JK	
CHK. BY: LFS	
DRAWING NO.: TX-4084	
SHEET 1 OF 10	

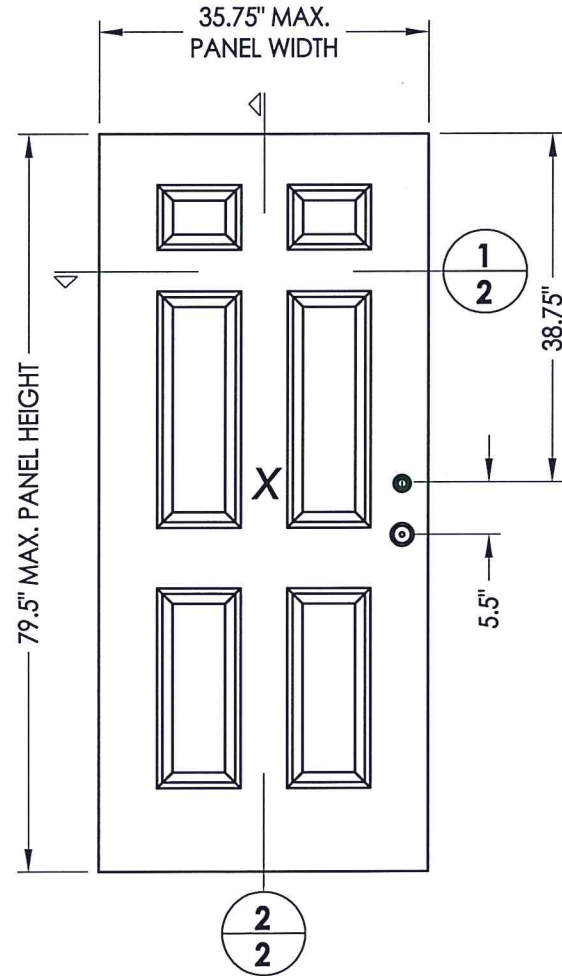

40 DOOR PANEL

FIBERGLASS DOOR SKIN: MIN. 0.079" THK.
CORE MATERIAL: EPS FOAM (POLYSTYRENE)

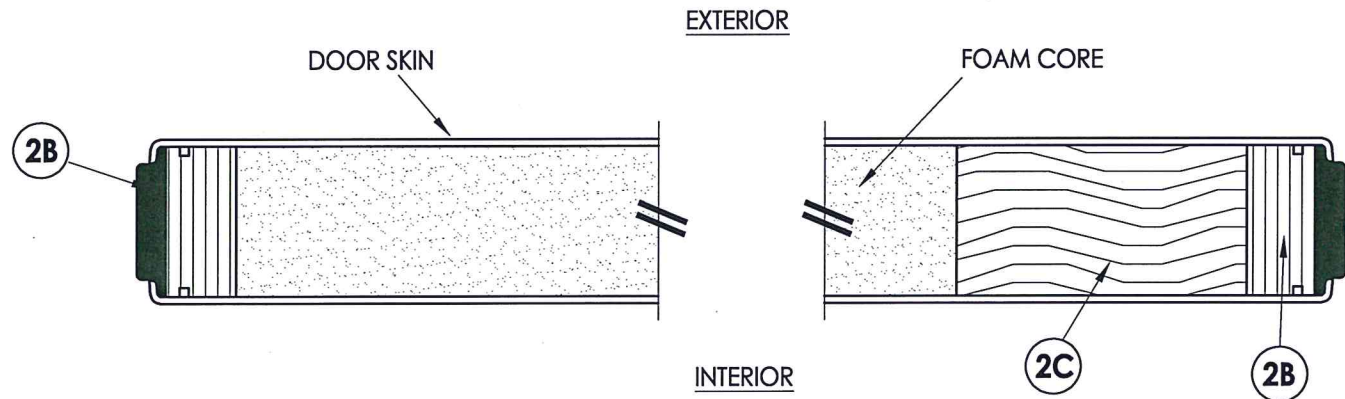

1 HORIZONTAL CROSS SECTION

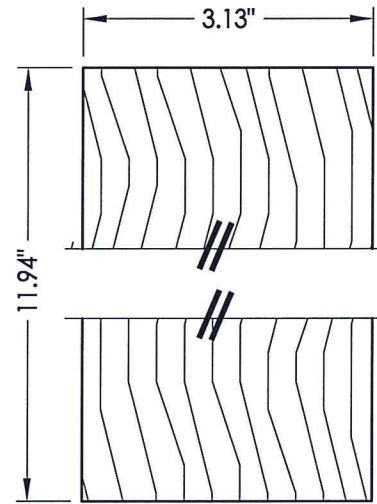
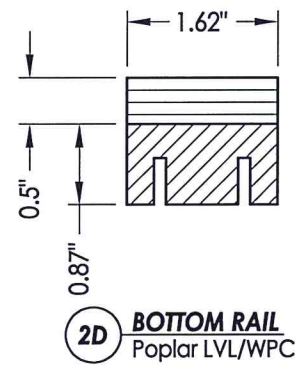
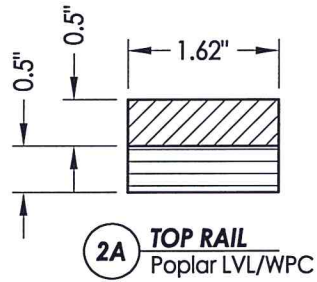
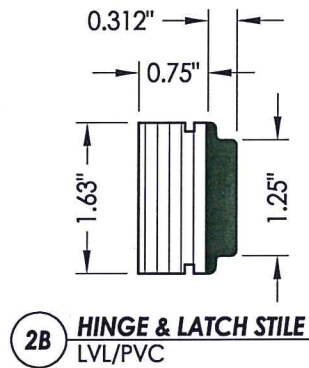

2 VERTICAL CROSS SECTION

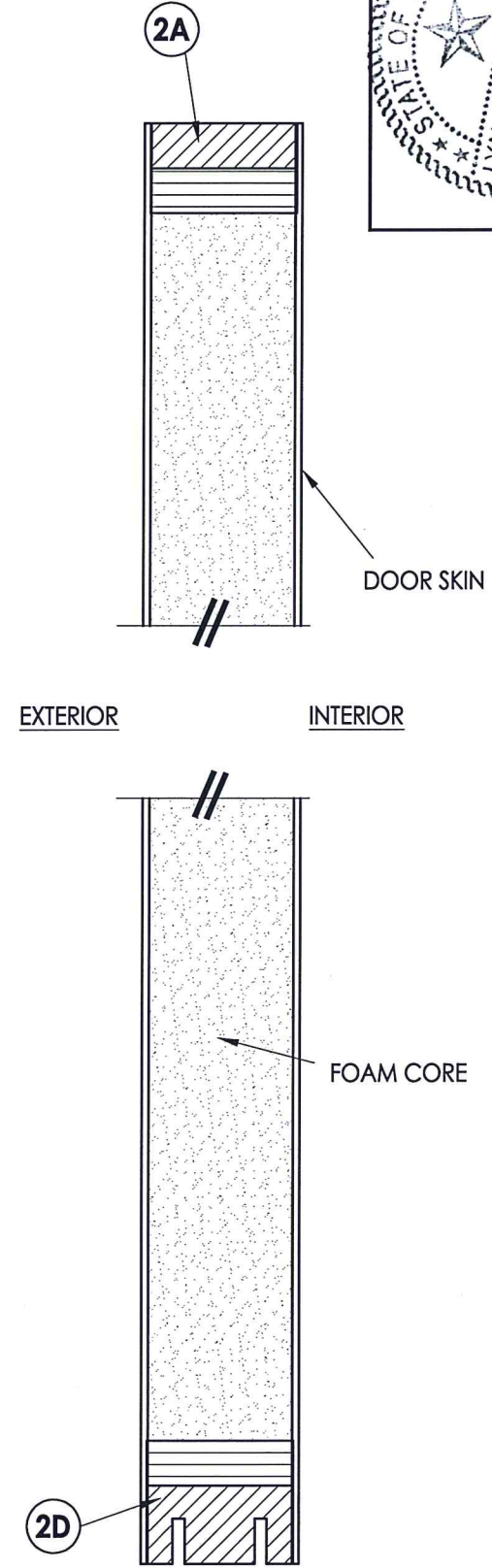

Documents Prepared By: Lyndon F. Schmidt, P.E.
TEXAS P.E. #104123

RW BUILDING CONSULTANTS, INC.
P.O. Box 230 Valrico FL 33595
Phone No.: 813.659.9197

TEXAS BOARD OF PROFESSIONAL ENGINEERS
CERTIFICATE OF REGISTRATION # F-11852

PRODUCT: STEVES AND SONS FIBERGLASS DOOR

PART OR ASSEMBLY: DOOR PANEL DETAILS

NO.	DATE	REVISIONS
2	5/28/20	UPDATE TO 2018 IBC/IRC CODE AND REVISE IMPACT LITE FRAME
1	7/21/15	Manuf./Product Name Change
		BY

DATE: 04/13/10
SCALE: N.T.S.
DWG. BY: JK
CHK. BY: LFS
DRAWING NO.: TX-4084
SHEET 2 OF 10

R:\Clients\Steves and Sons - Permanent\B - Texas Dept of Ins\Hinged Doors-Fiberglass\DR 427 Opaque Fiberglass Doors\C - Drawings\TX-4084-85.dwg, 3-1

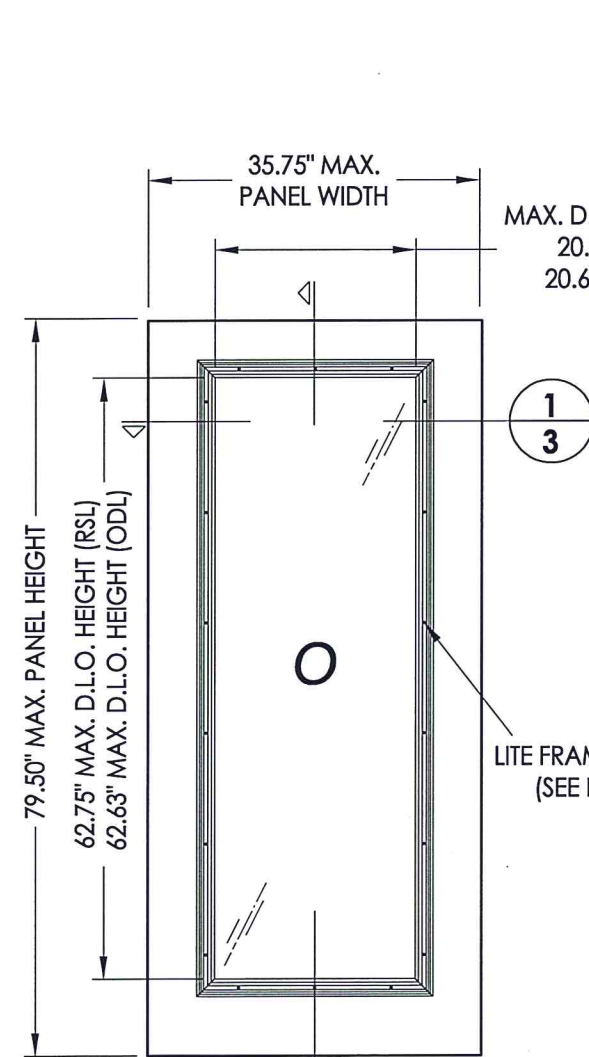
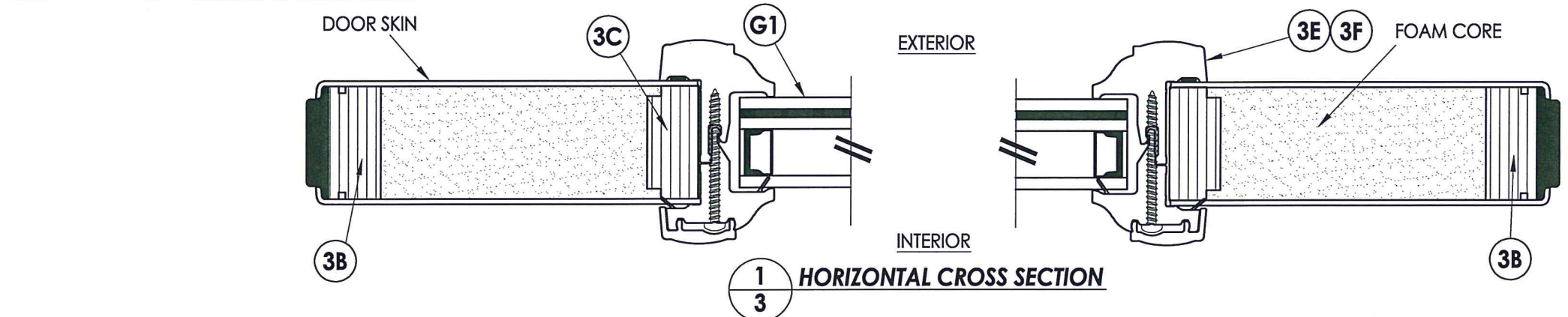

50 SIDELITE PANEL

FIBERGLASS DOOR SKIN: MIN. 0.079\"/>

NOTE:
 1. Spacing for lite frame screws is as follows:
 Sides: 4.5\"/>

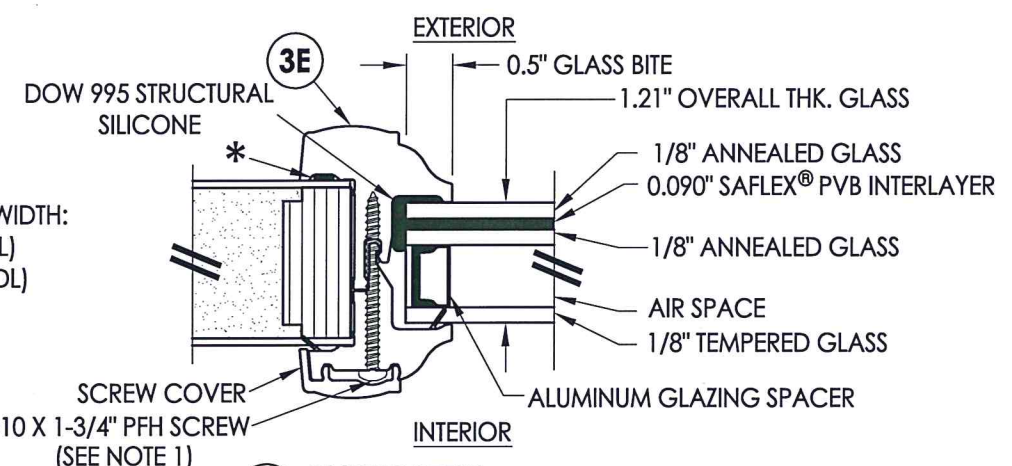

G1 GLAZING DETAIL
RSL Lite Frame

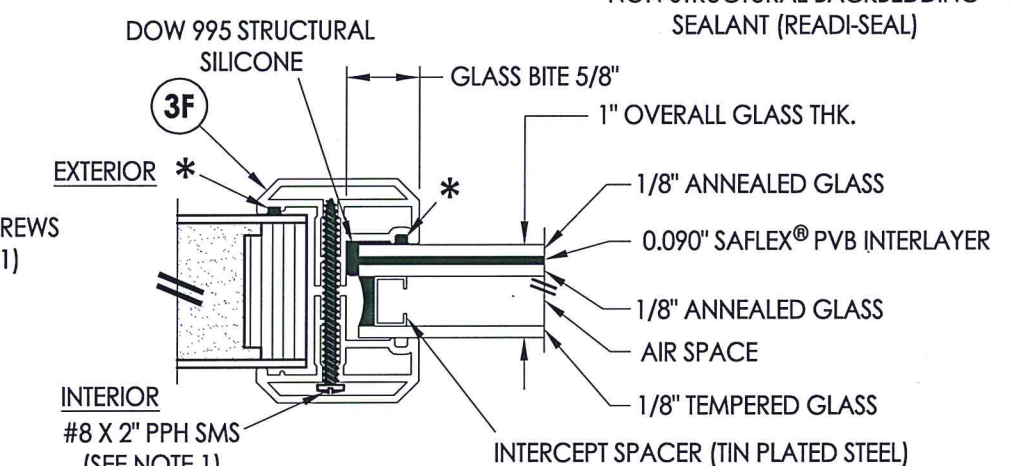

G2 GLAZING DETAIL
ODL Lite Frame

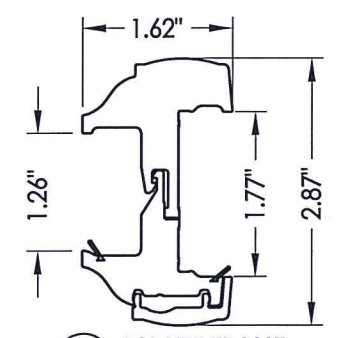

3E RSL LITE FRAME
PVC

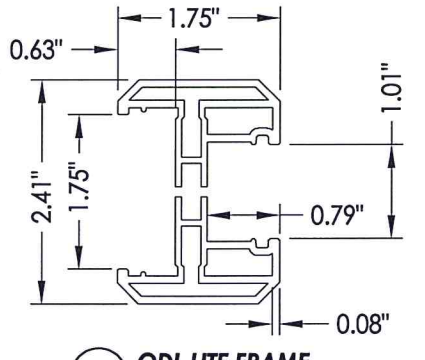

3F ODL LITE FRAME
Aluminum

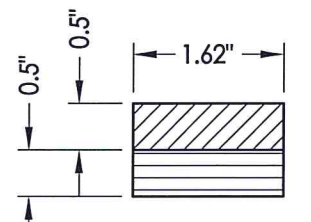

3A TOP RAIL
Poplar LVL/WPC

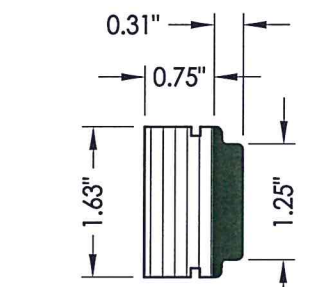

3B HINGE & LATCH STILE
LVL/PVC

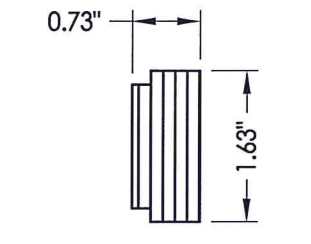

3C LITE OPENING
LVL Reinforcement

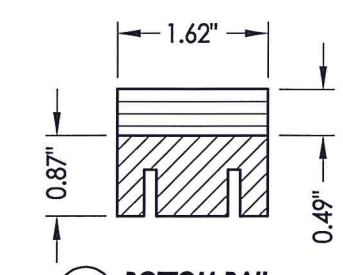

3D BOTTOM RAIL
Poplar LVL/WPC

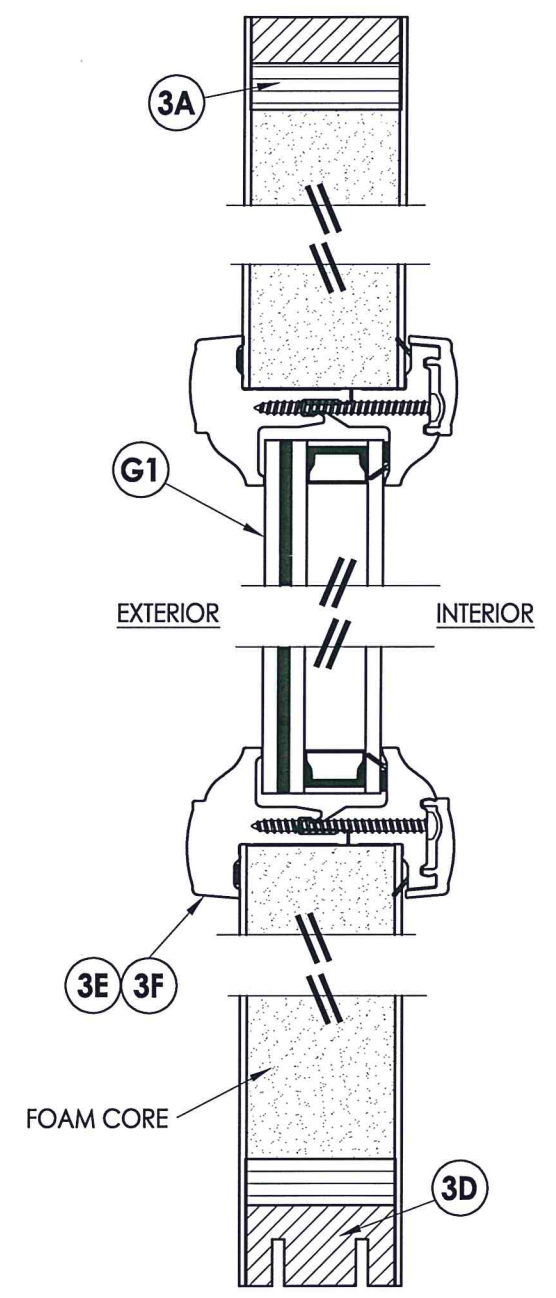

2 VERTICAL CROSS SECTION

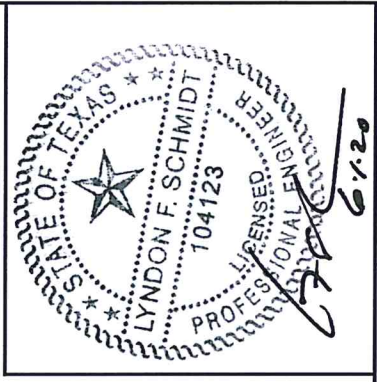

Documents Prepared By: Lyndon F. Schmidt, P.E.
 TEXAS P.E. #104123

RW BUILDING CONSULTANTS, INC.
 P.O. Box 230 Valrico FL 33595
 Phone No.: 813.659.9197

TEXAS BOARD OF PROFESSIONAL ENGINEERS
 CERTIFICATE OF REGISTRATION # F-11852

PRODUCT: STEVES AND SONS
 FIBERGLASS DOOR

PART OR ASSEMBLY:
 SIDELITE PANEL &
 GLAZING DETAILS

NO.	DATE	REVISIONS
2	5/28/20	UPDATE TO 2018 IBC/IRC CODE AND REVISE IMPACT LITE FRAME
1	7/21/15	Manuf./Product Name Change

DATE: 04/13/10
 SCALE: N.T.S.
 DWG. BY: JK
 CHK. BY: LFS
 DRAWING NO.: TX-4084
 SHEET 3 OF 10

HARDWARE CHART		
MANUFACTURER	MODEL	ITEM #
KWIKSET	LOCK: 200	17
	DEADBOLT: 600	18



Documents Prepared By: Lyndon F. Schmidt, P.E.
TEXAS P.E. #104123

RW BUILDING CONSULTANTS, INC.
P.O. Box 230 Valrico FL 33595
Phone No.: 813.659.9197

TEXAS BOARD OF PROFESSIONAL ENGINEERS
CERTIFICATE OF REGISTRATION # F-11852

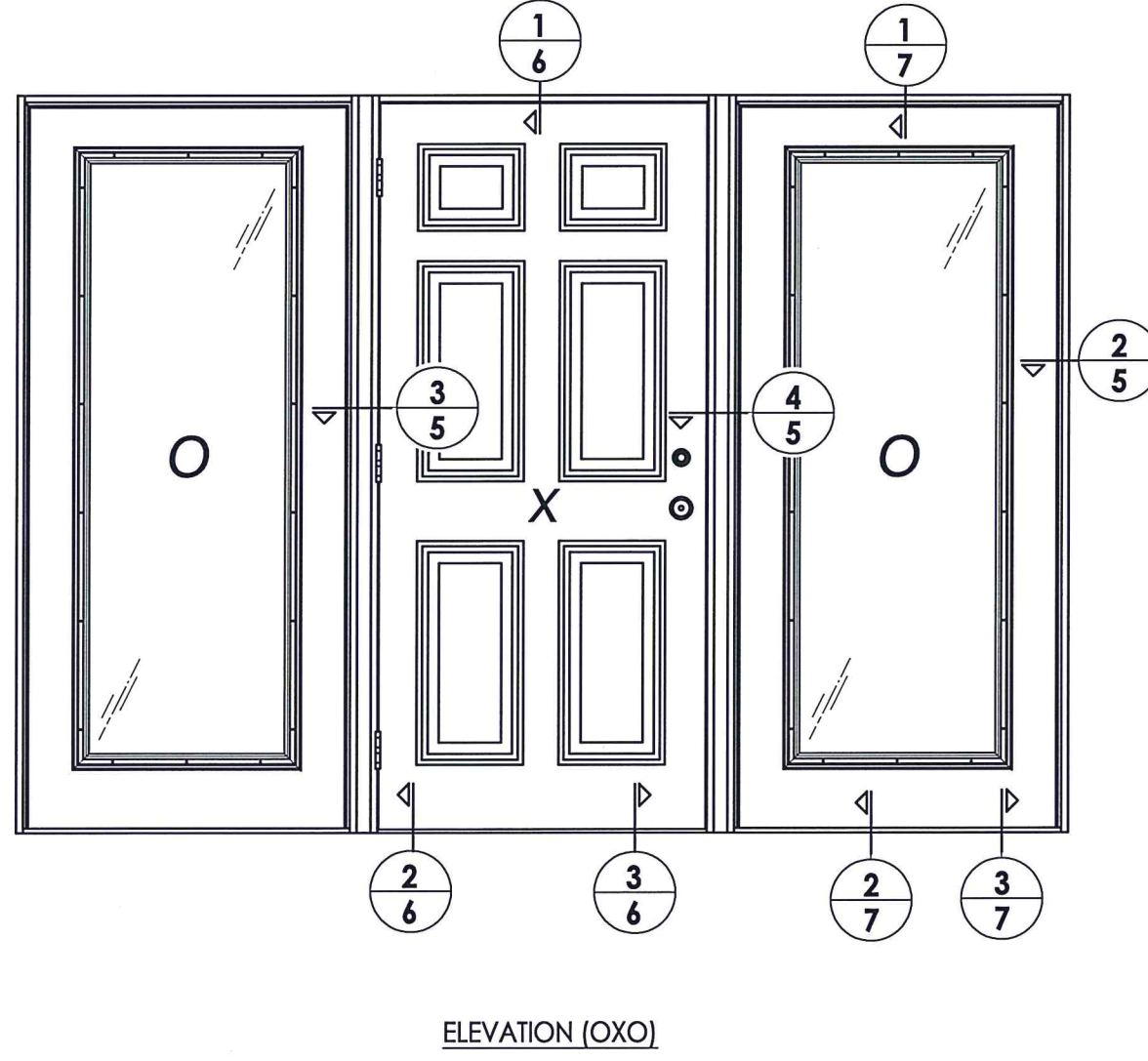
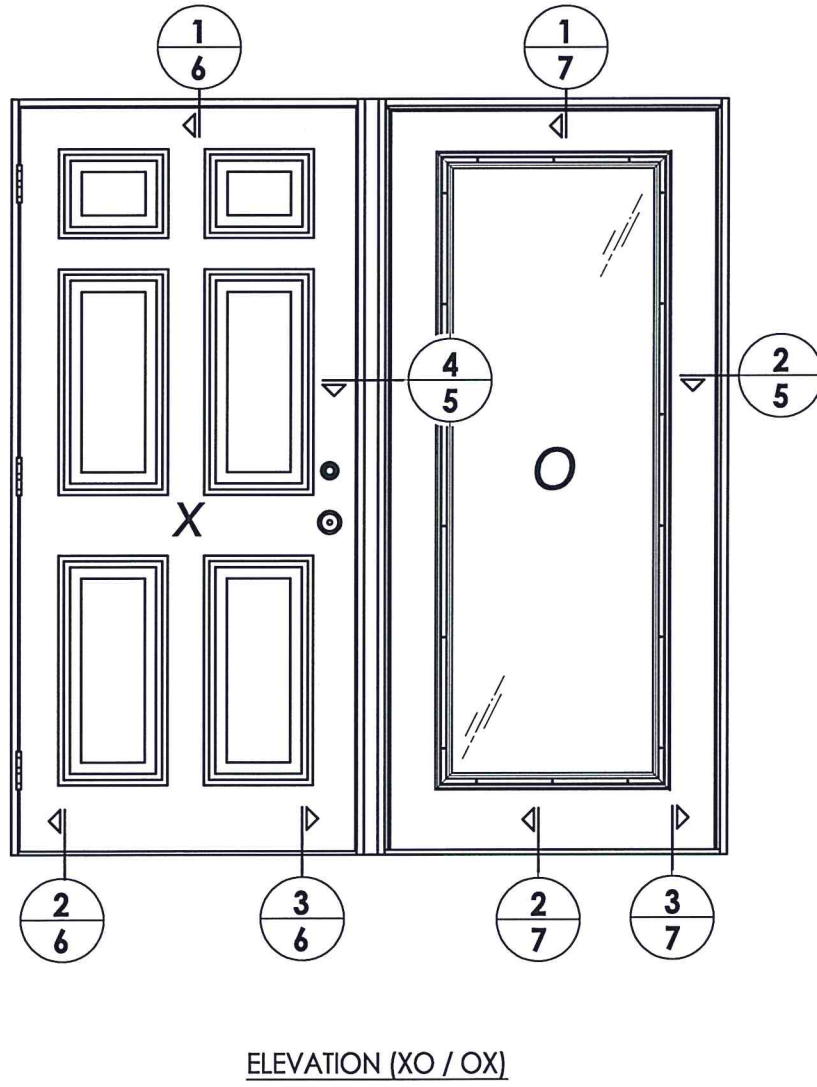
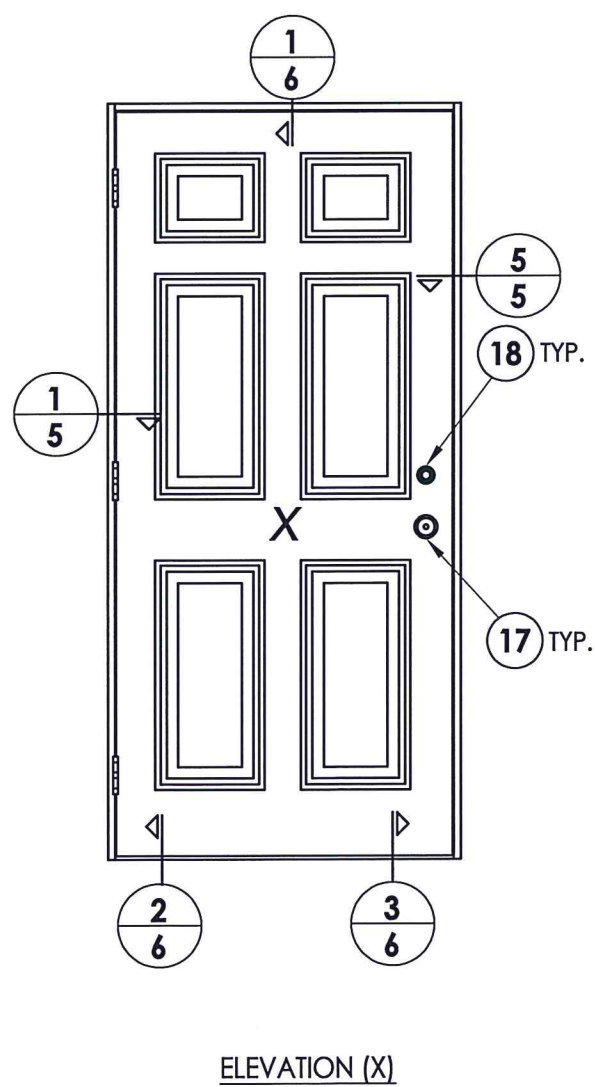

PRODUCT: STEVES AND SONS FIBERGLASS DOOR	
PART OR ASSEMBLY: ELEVATIONS	
NO.	DATE
2	5/28/20
1	7/21/15
REVISIONS	
UPDATE TO 2018 IBC/IRC CODE AND REVISE IMPACT LITE FRAME	LFS
Manuf./Product Name Change	LFS
BY	
DATE: 04/13/10	
SCALE: N.T.S.	
DWG. BY: JK	
CHK. BY: LFS	
DRAWING NO.: TX-4084	
SHEET 4 OF 10	

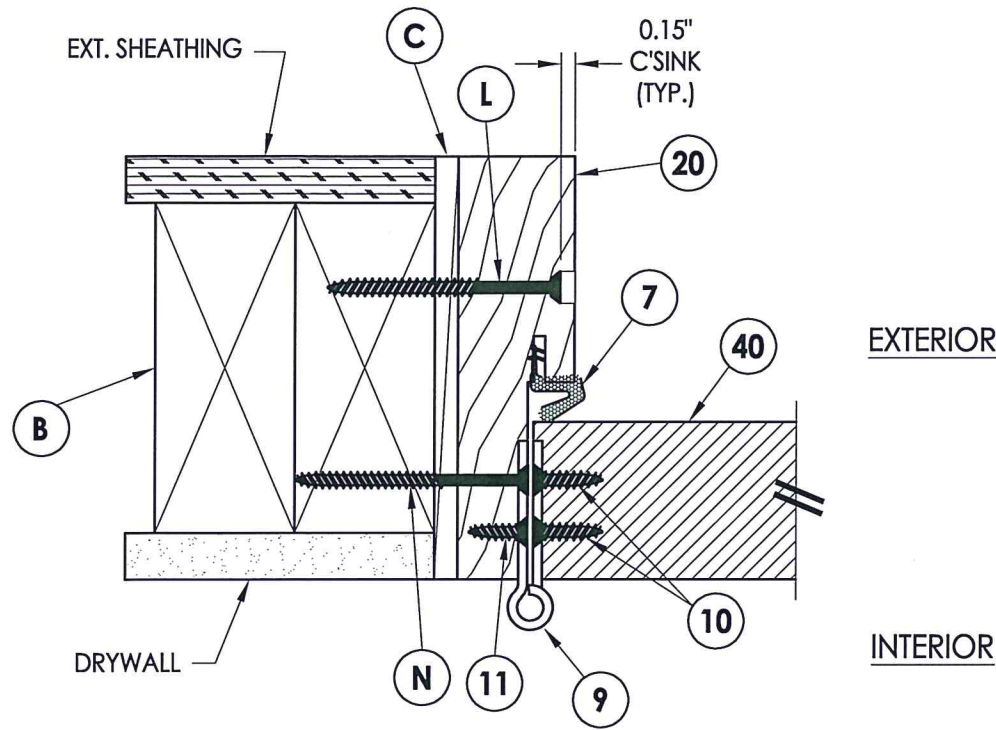

1 HORIZONTAL CROSS SECTION
5 Inswing shown - outswing also approved

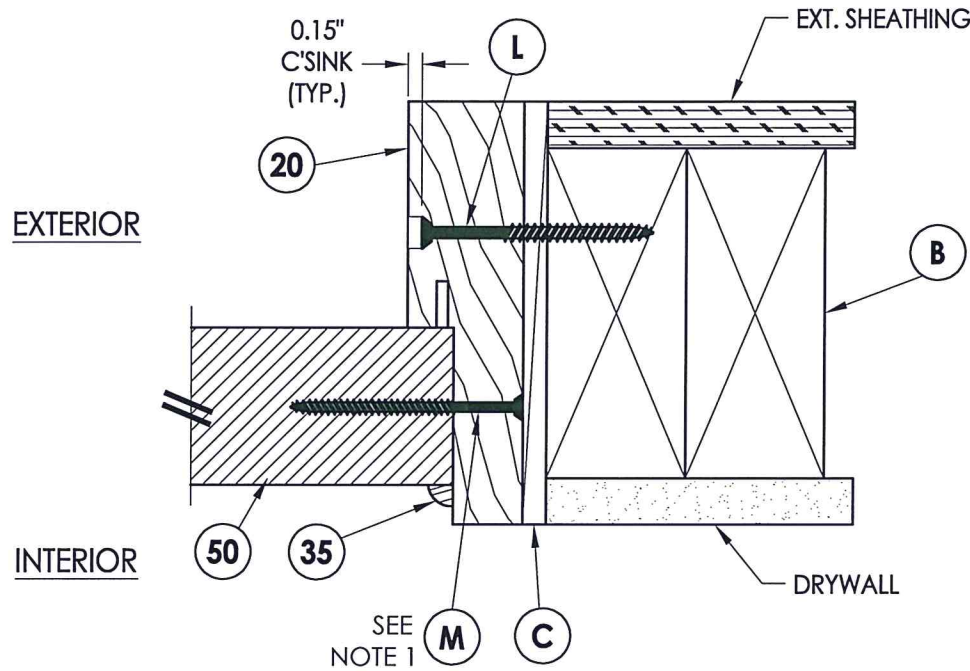

2 HORIZONTAL CROSS SECTION
5 Inswing shown - outswing also approved

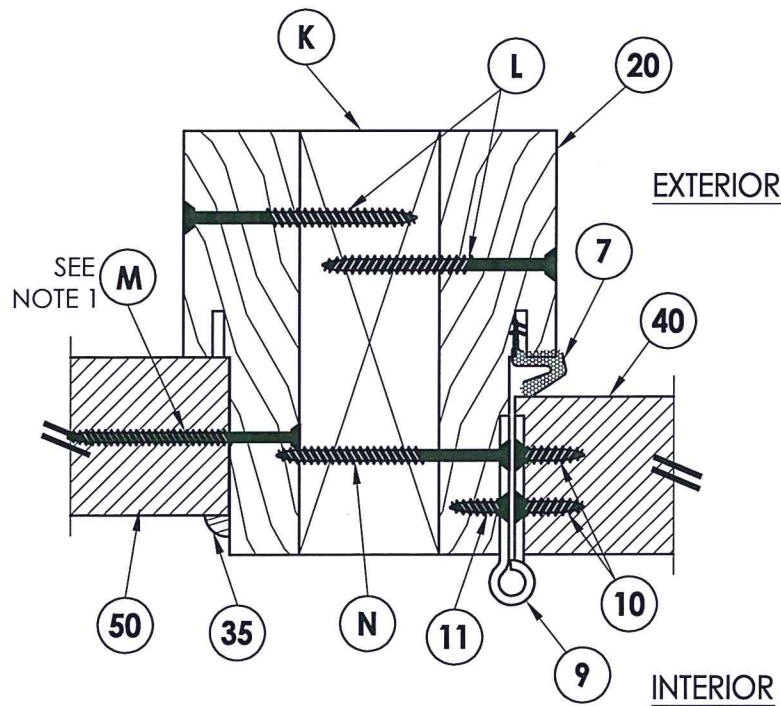

3 HORIZONTAL CROSS SECTION
5 Inswing shown - outswing also approved

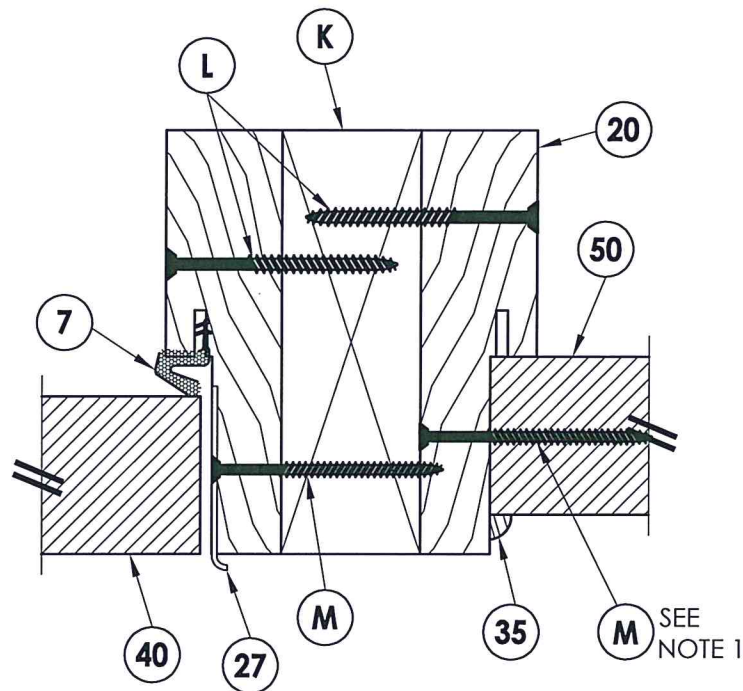

4 HORIZONTAL CROSS SECTION
5 Inswing shown - outswing also approved

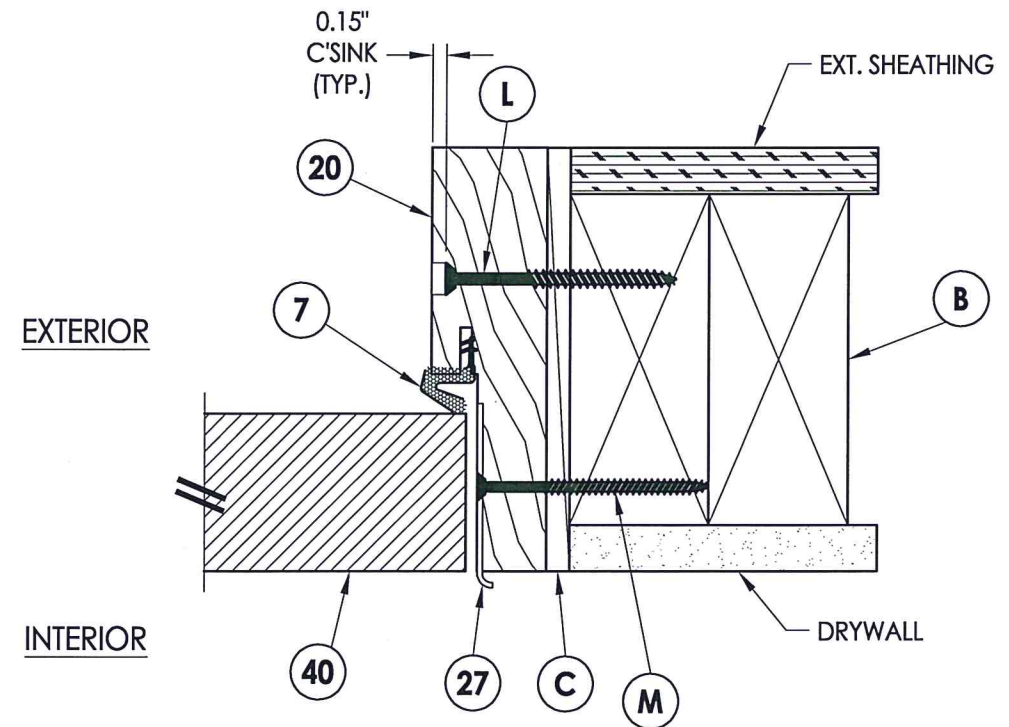

5 HORIZONTAL CROSS SECTION
5 Inswing shown - outswing also approved

NOTE:

- Sidelite ass'y fasteners located 6" from each end and 6 more screws equally spaced between (8 screws total per jamb).

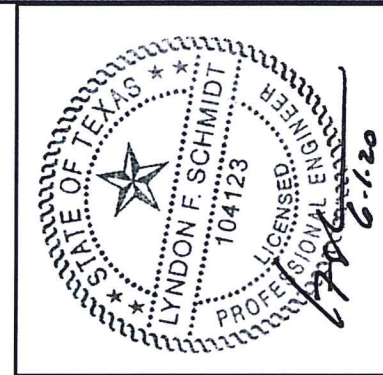

Documents Prepared By: Lyndon F. Schmidt, P.E.
 TEXAS P.E. #104123

RW BUILDING CONSULTANTS, INC.
 P.O. Box 230 Valrico FL 33595
 Phone No.: 813.659.9197
 TEXAS BOARD OF PROFESSIONAL ENGINEERS
 CERTIFICATE OF REGISTRATION # F-11852

PRODUCT: STEVES AND SONS
 FIBERGLASS DOOR
 PART OR ASSEMBLY:
 HORIZONTAL CROSS SECTIONS

NO.	DATE	REVISIONS	BY
2	5/28/20	UPDATE TO 2018 IBC/IRC CODE AND REVISE IMPACT LITE FRAME	LFS
1	7/21/15	Manuf./Product Name Change	LFS

DATE: 04/13/10
 SCALE: N.T.S.
 DWG. BY: JK
 CHK. BY: LFS
 DRAWING NO.: TX-4084
 SHEET 5 OF 10

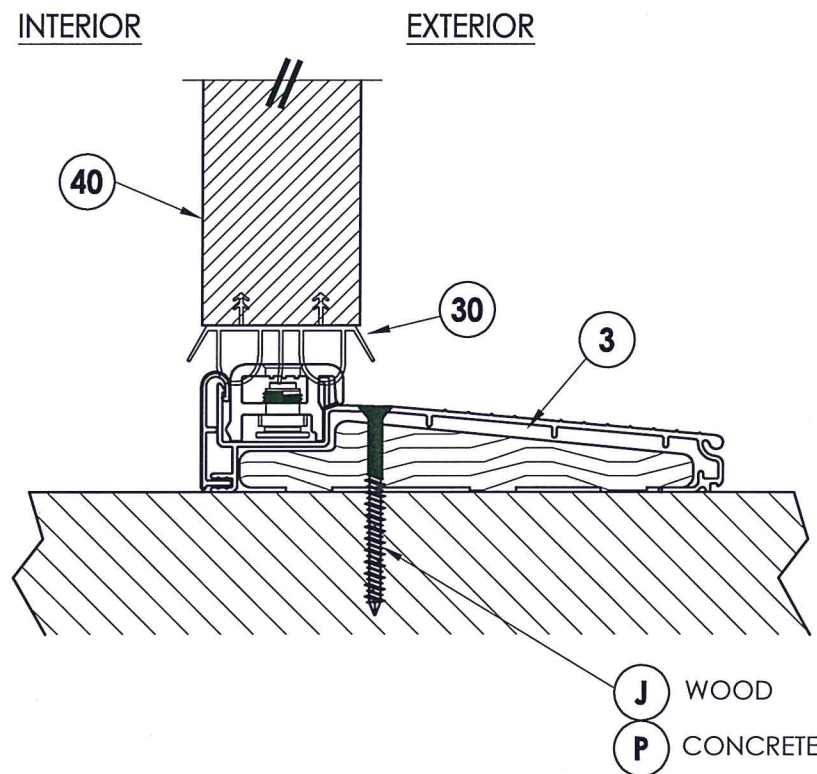

2 VERTICAL CROSS SECTION
 6 Inswing configuration

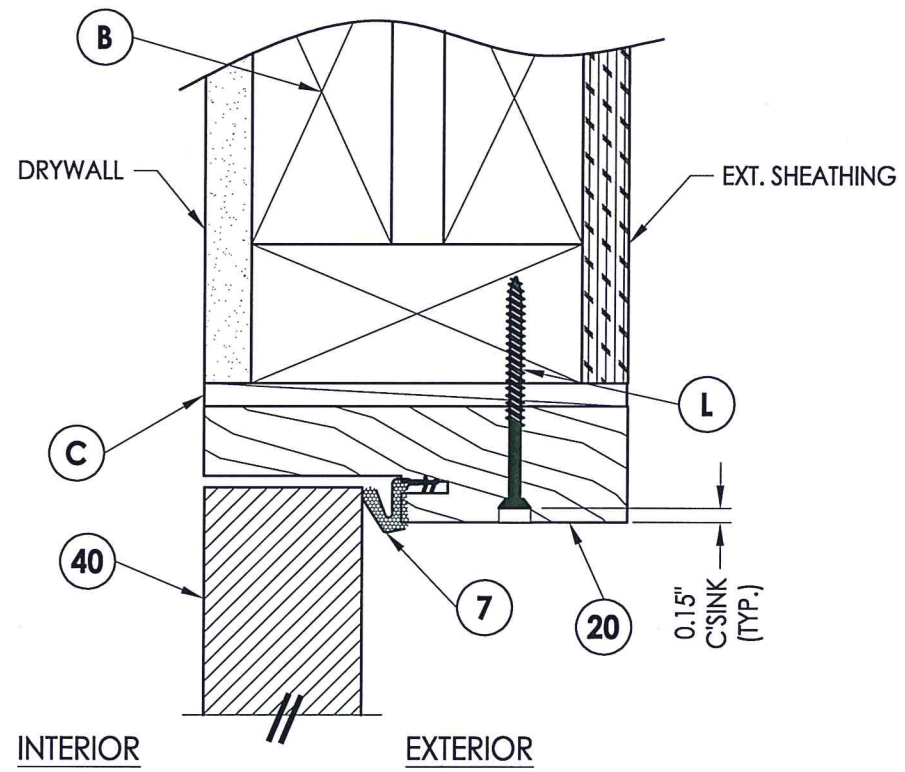

1 VERTICAL CROSS SECTION
 6 Inswing shown - outswing also approved

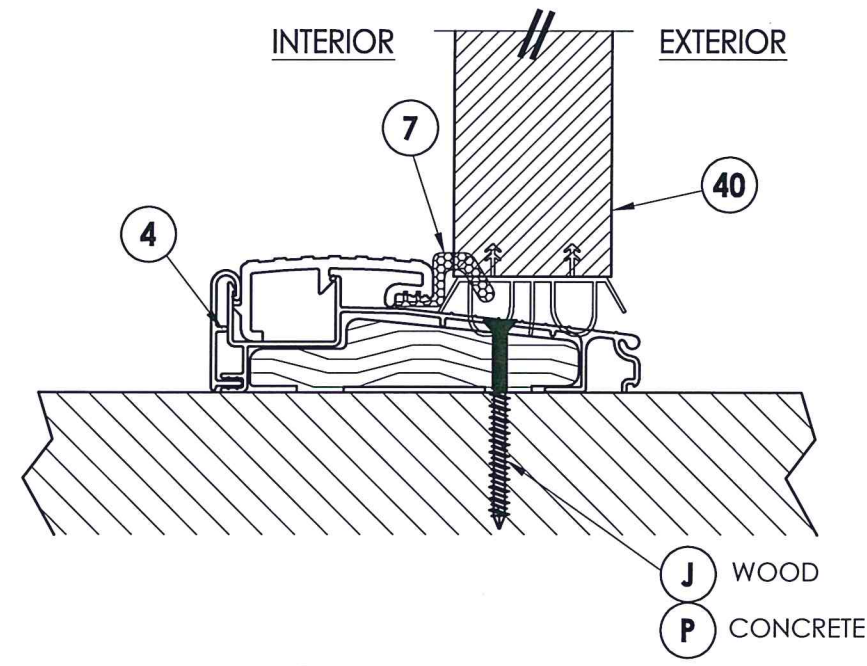

3 VERTICAL CROSS SECTION
 6 Outswing configuration

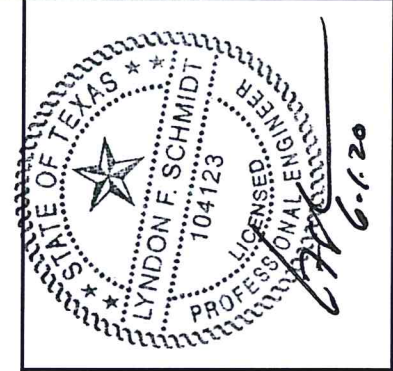

Documents Prepared By: Lyndon F. Schmidt, P.E.
 TEXAS P.E. #104123

RW BUILDING CONSULTANTS, INC.
 P.O. Box 230 Valrico FL 33595
 Phone No.: 813.659.9197

TEXAS BOARD OF PROFESSIONAL ENGINEERS
 CERTIFICATE OF REGISTRATION # F-11852

PRODUCT: STEVES AND SONS FIBERGLASS DOOR

PART OR ASSEMBLY: VERTICAL CROSS SECTIONS

NO.	DATE	REVISIONS	BY
2	5/28/20	UPDATE TO 2018 IBC/IRC CODE AND REVISE IMPACT LITE FRAME	LFS
1	7/21/15	Manuf./Product Name Change	LFS

DATE: 04/13/10
 SCALE: N.T.S.
 DWG. BY: JK
 CHK. BY: LFS
 DRAWING NO.: TX-4084
 SHEET 6 OF 10

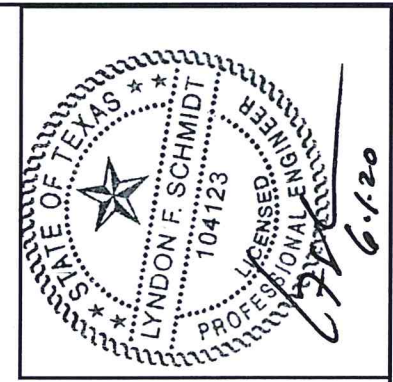

Documents Prepared By: Lyndon F. Schmidt, P.E.
 TEXAS P.E. #104123

RW BUILDING CONSULTANTS, INC.
 P.O. Box 230 Valrico FL 33595
 Phone No.: 813.659.9197

TEXAS BOARD OF PROFESSIONAL ENGINEERS
 CERTIFICATE OF REGISTRATION # F-11852

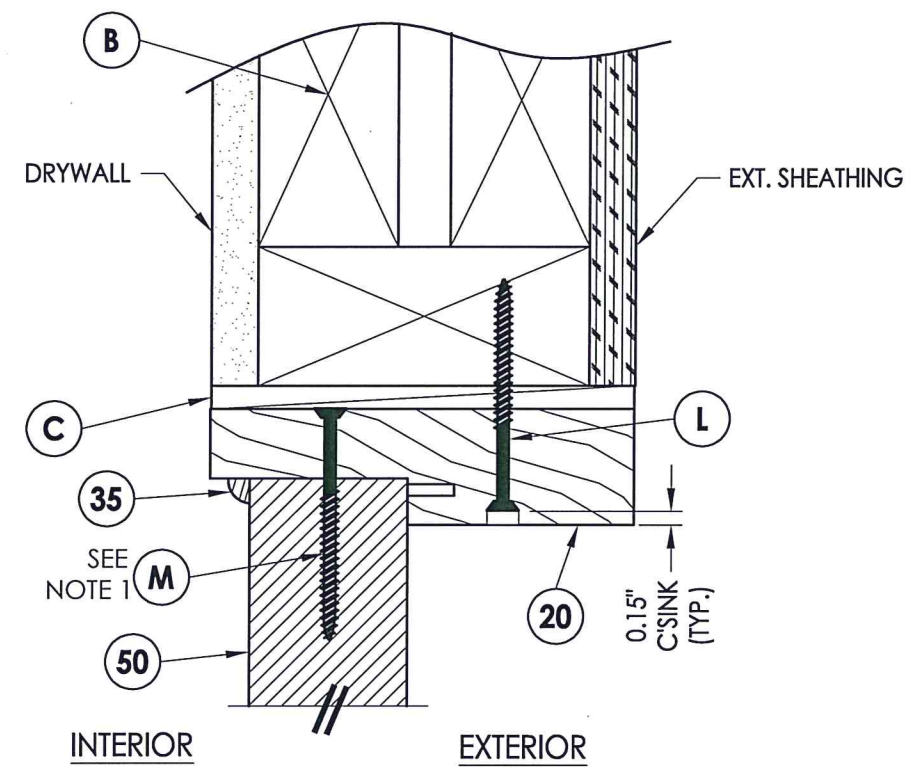

1 VERTICAL CROSS SECTION
7 Inswing shown - outswing also approved

NOTE:
 1. Screws thru head and sill jamb located 3" from each end and on center line.

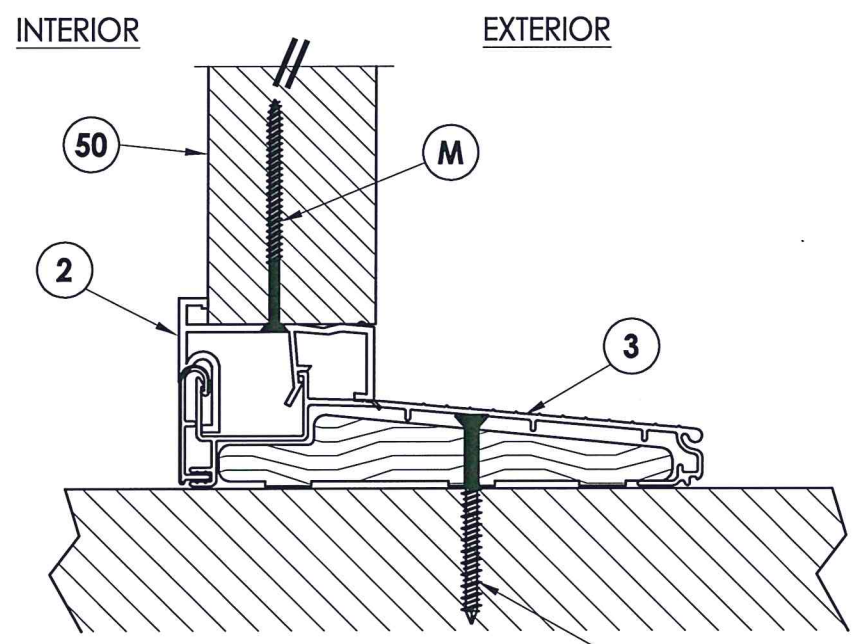

2 VERTICAL CROSS SECTION
7 Inswing configuration

J WOOD
P CONCRETE

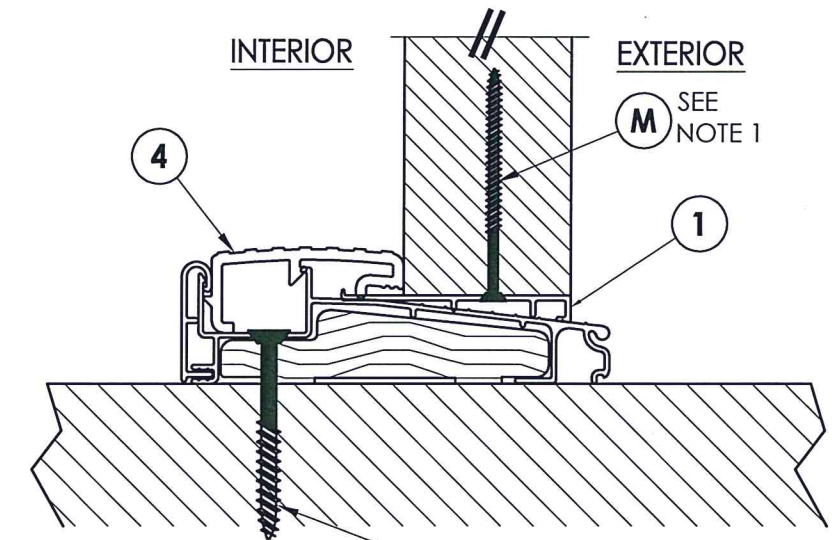

3 VERTICAL CROSS SECTION
7 Outswing configuration

J WOOD
P CONCRETE

PRODUCT: STEVES AND SONS FIBERGLASS DOOR		PART OR ASSEMBLY: VERTICAL CROSS SECTIONS	
NO.	DATE	BY	REVISIONS
2	5/28/20	LFS	UPDATE TO 2018 IBC/IRC CODE AND REVISE IMPACT LITE FRAME
1	7/21/15	LFS	Manuf./Product Name Change

DATE: 04/13/10
 SCALE: N.T.S.
 DWG. BY: JK
 CHK. BY: LFS
 DRAWING NO.: TX-4084
 SHEET 7 OF 10

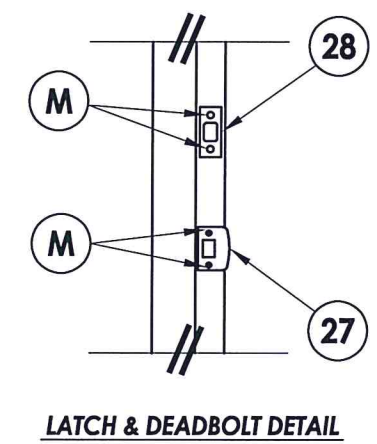
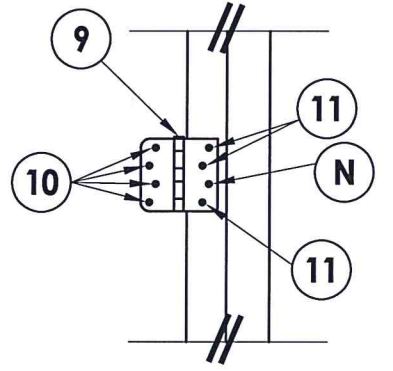
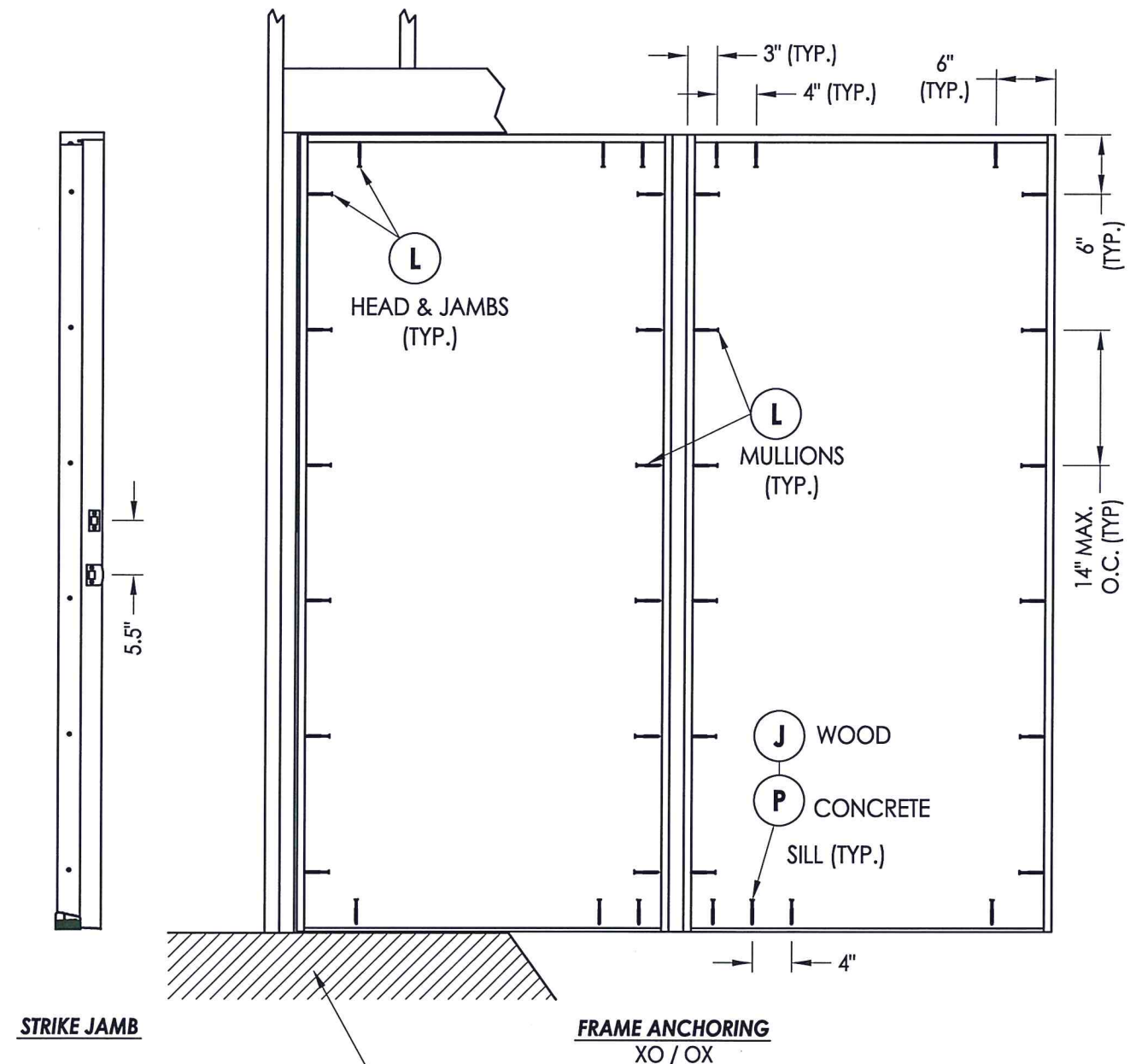
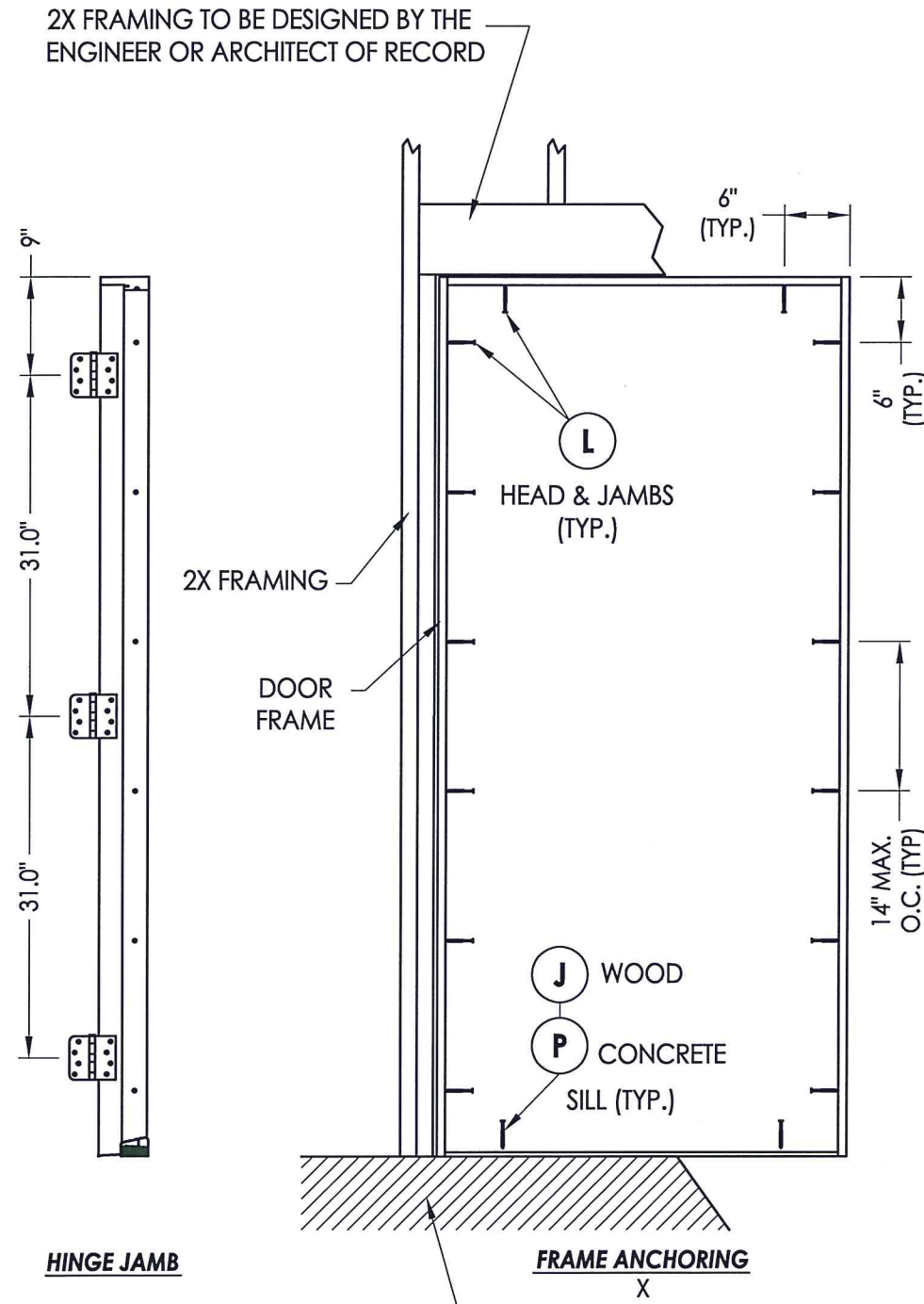

Documents Prepared By: Lyndon F. Schmidt, P.E.
TEXAS P.E. #104123

RW BUILDING CONSULTANTS, INC.
P.O. Box 230 Valrico FL 33595
Phone No.: 813.659.9197

TEXAS BOARD OF PROFESSIONAL ENGINEERS
CERTIFICATE OF REGISTRATION # F-11852

PRODUCT: STEVES AND SONS FIBERGLASS DOOR

PART OR ASSEMBLY: FRAME ANCHORING

NO.	DATE	REVISIONS	BY
2	5/28/20	UPDATE TO 2018 IBC/IRC CODE AND REVISE IMPACT LITE FRAME	LFS
1	7/21/15	Manuf./Product Name Change	LFS

DATE: 04/13/10

SCALE: N.T.S.

DWG. BY: JK

CHK. BY: LFS

DRAWING NO.: TX-4084

SHEET 8 OF 10



Documents Prepared By: Lyndon F. Schmidt, P.E.
TEXAS P.E. #104123

RW BUILDING CONSULTANTS, INC.
P.O. Box 230 Vairico FL. 33595
Phone No.: 813.659.9197
TEXAS BOARD OF PROFESSIONAL ENGINEERS
CERTIFICATE OF REGISTRATION # F-11852

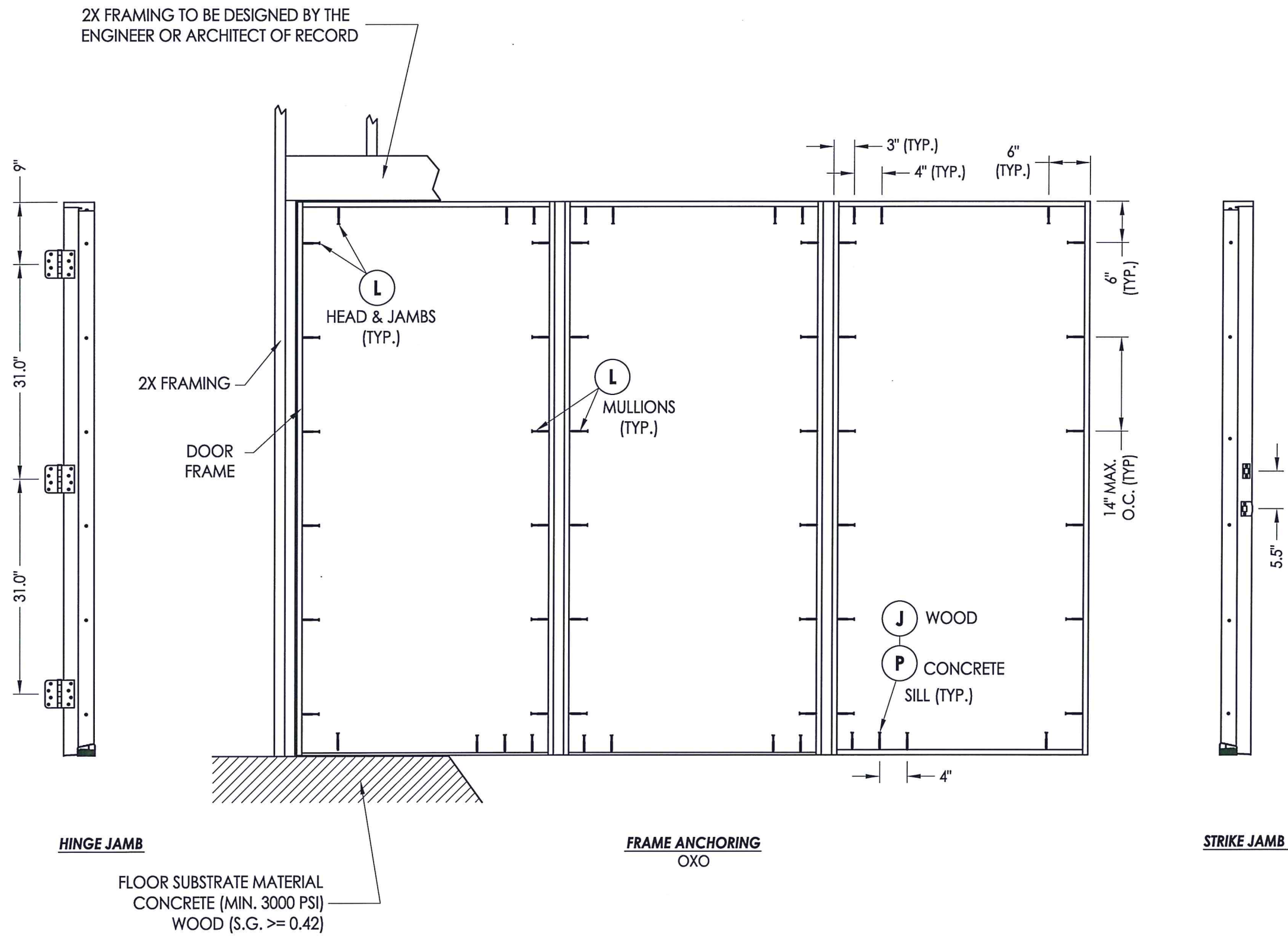

HINGE JAMB

FRAME ANCHORING
OXO

STRIKE JAMB

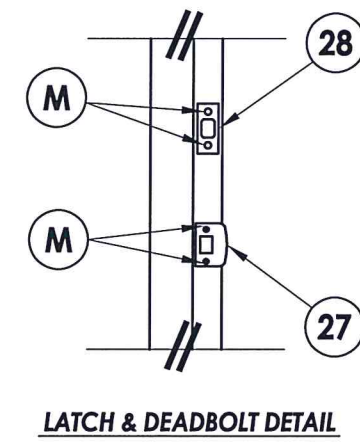
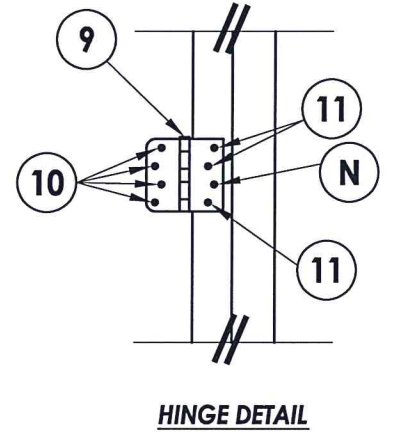

PRODUCT:		STEVES AND SONS FIBERGLASS DOOR	
PART OR ASSEMBLY:		FRAME ANCHORING	
NO.	DATE	BY	REVISIONS
2	5/28/20	LFS	UPDATE TO 2018 IBC/IRC CODE AND REVISE IMPACT LITE FRAME
1	7/21/15	LFS	Manuf./Product Name Change

DATE: 04/13/10
SCALE: N.T.S.
DWG. BY: JK
CHK. BY: LFS
DRAWING NO.: TX-4084
SHEET 9 OF 10

BILL OF MATERIALS

ITEM #	DESCRIPTION	MATERIAL
B	2X FRAMING (SG >= 0.42)	WOOD
C	1/4" MAX. SHIM SPACE	-
J	#10 X 3" PFH WOOD SCREW	STEEL
K	2X REINFORCEMENT (CLEAR PINE SG >= 0.42)	WOOD
L	#10 X 2-1/2" PFH WOOD SCREW (1.15" MIN. EMBEDMENT)	STEEL
M	#8 X 2-1/2" PFH WOOD SCREW	STEEL
N	#9 X 2-1/2" PFH WOOD SCREW	STEEL
P	1/4" PFH ELCO OR ITW CONCRETE SCREW (1-3/4" MIN. EMB.)	STEEL
1	SIDELITE SPACER -OUTSWING	-
2	SIDELITE SPACER -INSWING	-
3	INSWING THRESHOLD ALUMINUM W/ COMPOSITE SUBSTRATE	ALUM/COMP.
4	OUTSWING THRESHOLD ALUMINUM W/ COMPOSITE SUBSTRATE	ALUM/COMP.
7	WEATHERSTRIP BY Q-LON	FOAM
9	4" HINGE	STEEL
10	#9 X 1" PFH WOOD SCREW	STEEL
11	#9 X 5/8" PFH WOOD SCREW	STEEL
20	JAMB FINGER - JOINT - PINE (SG >= 0.42)	WOOD
27	LATCH STRIKE PLATE	STEEL
28	DEADBOLT PLATE	STEEL
30	DOOR SWEEP	PVC
35	QUARTER ROUND	WOOD
40	DOOR PANEL - SEE DOOR PANEL DETAIL SHEET FOR CONSTRUCTION DETAILS	-
50	SIDELITE PANEL - SEE SIDELITE PANEL DETAIL SHEET FOR CONSTRUCTION DETAILS	-

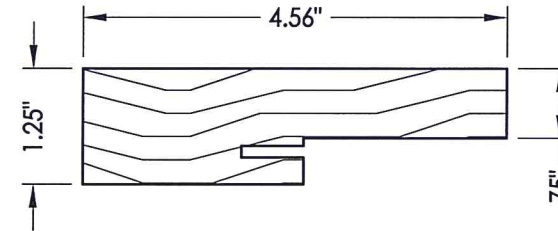

20 HEAD & SIDE Jamb

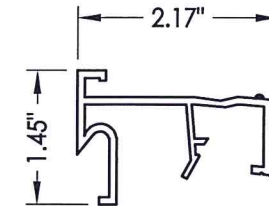

2 SIDELITE SPACER Inswing

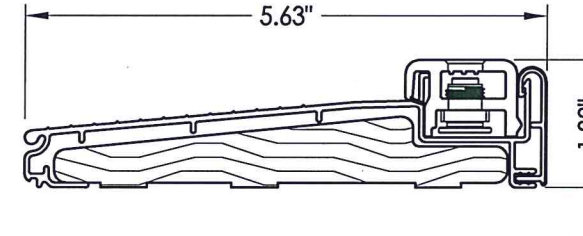

3 INSWING THRESHOLD

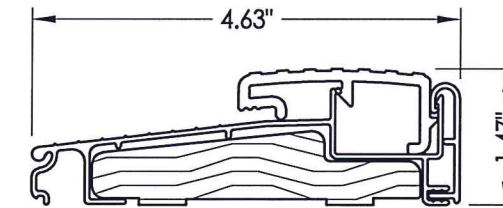

4 OUTSWING THRESHOLD

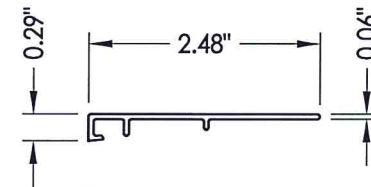

1 SIDELITE SPACER Outswing

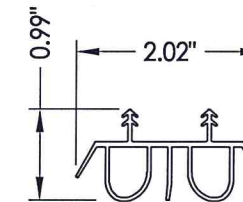

30 SWEEP

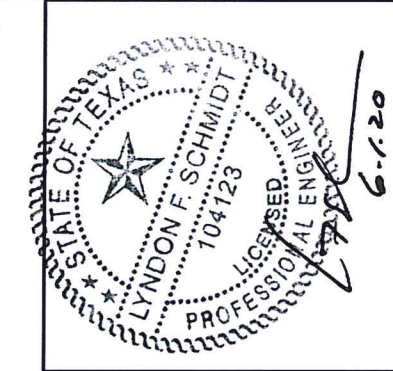

Documents Prepared By: Lyndon F. Schmidt, P.E.
TEXAS P.E. #104123

RW BUILDING CONSULTANTS, INC.
P.O. Box 230 Valrico FL 33595
Phone No.: 813.659.9197
TEXAS BOARD OF PROFESSIONAL ENGINEERS
CERTIFICATE OF REGISTRATION # F-11852

PRODUCT: STEVES AND SONS FIBERGLASS DOOR
PART OR ASSEMBLY: COMPONENTS AND B.O.M.

NO.	DATE	REVISIONS
2	5/28/20	UPDATE TO 2018 IBC/IRC CODE AND REVISE IMPACT LITE FRAME Manuf./Product Name Change
1	7/21/15	
		BY

DATE: 04/13/10
SCALE: N.T.S.
DWG. BY: JK
CHK. BY: LFS
DRAWING NO.: TX-4084
SHEET 10 OF 10

CONCRETE ANCHOR NOTES:

- Concrete anchor locations at the corners may be adjusted to maintain the min. edge distance to mortar joints.
- Concrete anchor locations noted as "MAX. ON CENTER" must be adjusted to maintain the min. edge distance to mortar joints, additional concrete anchors may be required to ensure the "MAX. ON CENTER" dimension are not exceeded.
- Concrete anchor table:

ANCHOR TYPE	ANCHOR SIZE	MIN. EMBEDMENT	MIN. CLEARANCE TO MASONRY EDGE	MIN. CLEARANCE TO ADJACENT ANCHOR
ITW TAPCON®	1/4"	1-3/4"	1-1/2"	4"
ELCO ULTRACON®	1/4"	1-3/4"	1"	4"