

**GLAZED FIBERGLASS SINGLE DOOR
w/ or w/o SIDELITES
IN SWING
"NON-IMPACT"**

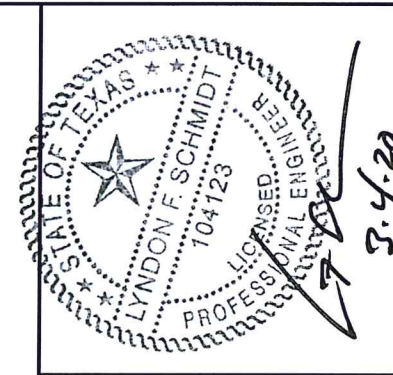

Documents Prepared By: Lyndon F. Schmidt, P.E.
TEXAS P.E. #104123

RW BUILDING CONSULTANTS, INC.
P.O. Box 230 Valrico FL, 33595
Phone No.: 813.689.9197

TEXAS BOARD OF PROFESSIONAL ENGINEERS
CERTIFICATE OF REGISTRATION # F-11852

EVALUATED FOR USE IN THE STATE OF TEXAS

The Glazed Fiberglass Door system described herein complies with the 2018 International Residential Code (IRC), Sections R301 & R609 and the 2018 International Building Code (IBC), Sections 1404.13, 1609, 1709.5, 2403 and 2404 subject to the following conditions:

1. Anchors shall be as listed and spaced as shown in the details. Anchor embedment to base material shall be beyond wall dressing or stucco.
2. When used in areas requiring wind-borne debris protection this product is required to be protected with an impact resistant covering that complies with Section R301.2.1.2 of the IRC and Section 1609.2 of the IBC.
3. Allowable design pressure requirements must be equal to or less than the design pressure rating shown in the design pressure chart, sheet 1 of this drawing.
4. Conditions not covered by this drawing are subject to further engineering analysis.

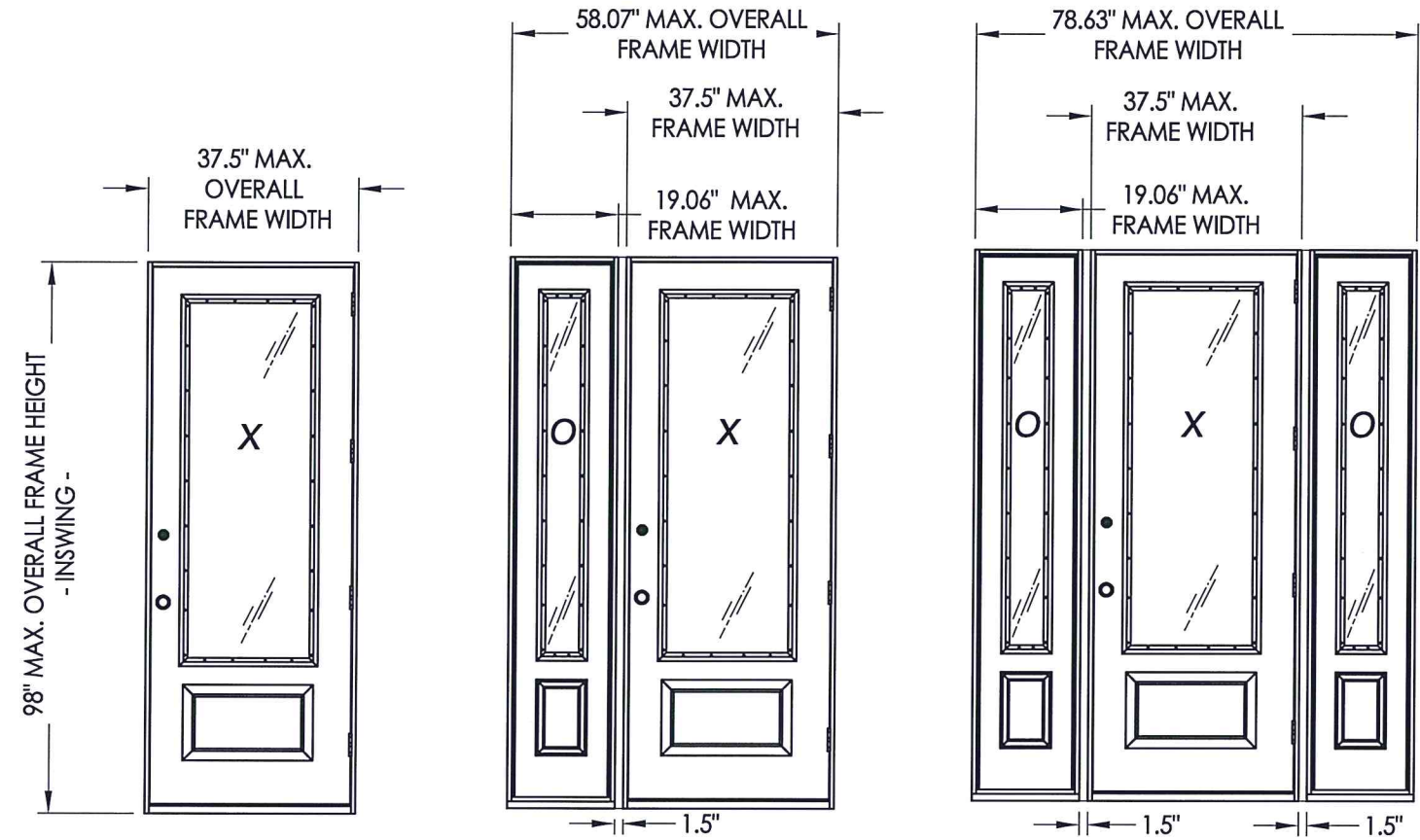

TABLE OF CONTENTS	
SHEET#	DESCRIPTION
1	Typical elevations, design pressures & general notes
2	Door panel details
3	Sidelite panel details and glazing detail
4	Elevations
5	Horizontal cross section
6	Vertical cross sections
7	Vertical cross sections
8	Frame anchoring
9	Frame anchoring
10	Bill of materials and components

CONFIGURATION	MAX. FRAME DIMENSION	MAX. D.L.O. DIMENSION	DESIGN PRESSURE (PSF) IN SWING	
			POSITIVE	NEGATIVE
X	37.5" x 98.0"	21.12" x 63.12"	+40.0	-45.0
OX / XO	58.07" x 98.0"	21.12" x 63.12"	+40.0	-45.0
OXO	78.63" x 98.0"	21.12" x 63.12"	+40.0	-45.0

PRODUCT: MASTERGRAIN FIBERGLASS DOOR

PART OR ASSEMBLY: TYPICAL ELEVATION, DESIGN PRESSURES & GENERAL NOTES

NO.	DATE	UPDATE TO 2018 IBC/IRC CODE	LFS	BY
1	3/03/20			

REVISIONS

DATE: 01/04/10

SCALE: N.T.S.

DWG. BY: JK

CHK. BY: LFS

DRAWING NO.: TX-4044

SHEET 1 OF 10

R:\Clients\Mastergrain PERMANENT\B - Texas Dept of Ins\TDL - DR-422 Fiberglass Door\Drawings\TX 4044-4047.dwg, 2-44

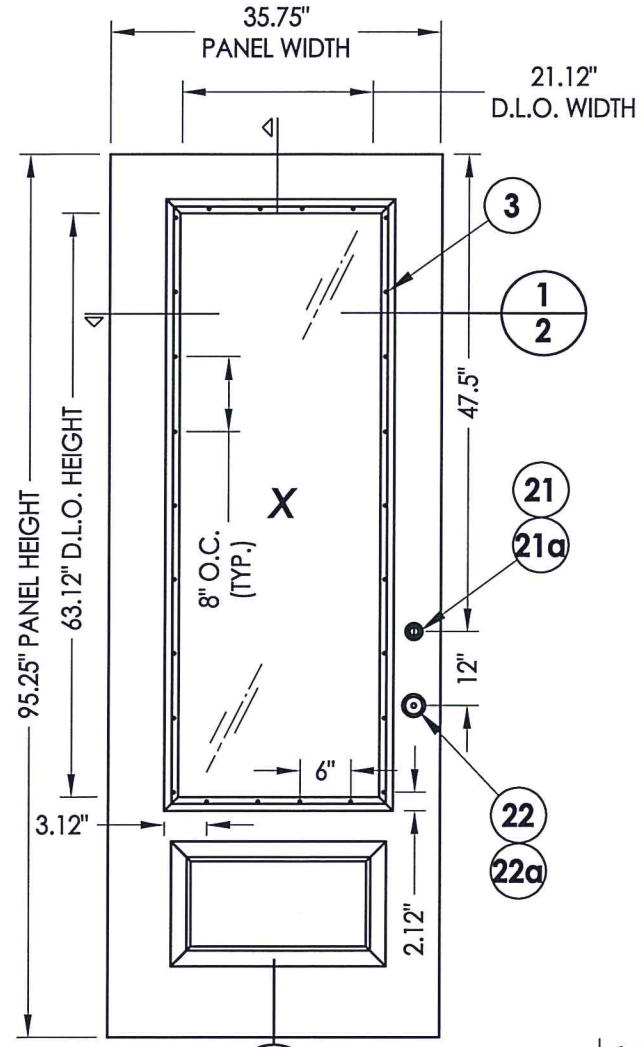

40 DOOR PANEL
Fiberglass

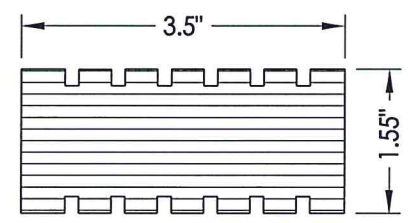

41 HINGE AND LATCH STILE
Reinforcement / LSL

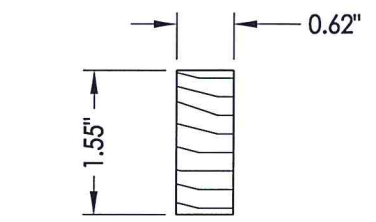

42 HINGE AND LATCH STILE
Wood

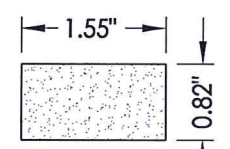

44 TOP RAIL
Composite

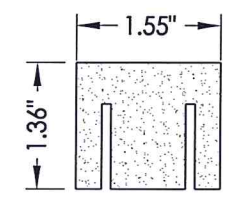

45 BOTTOM RAIL
Composite

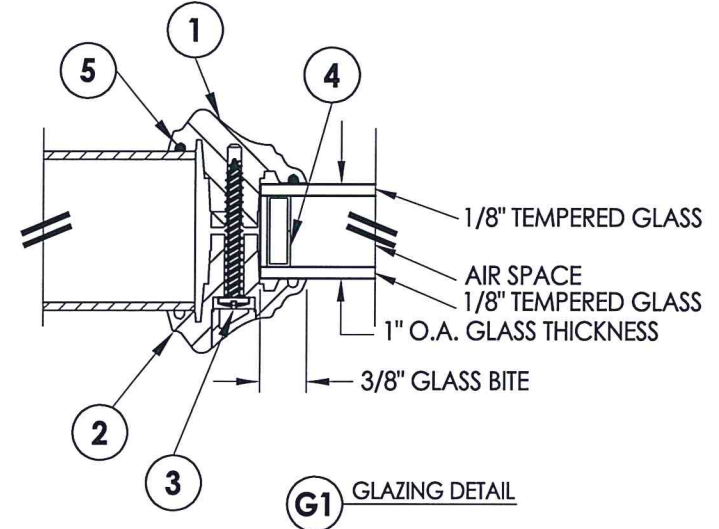

G1 GLAZING DETAIL

1 HORIZONTAL CROSS SECTION

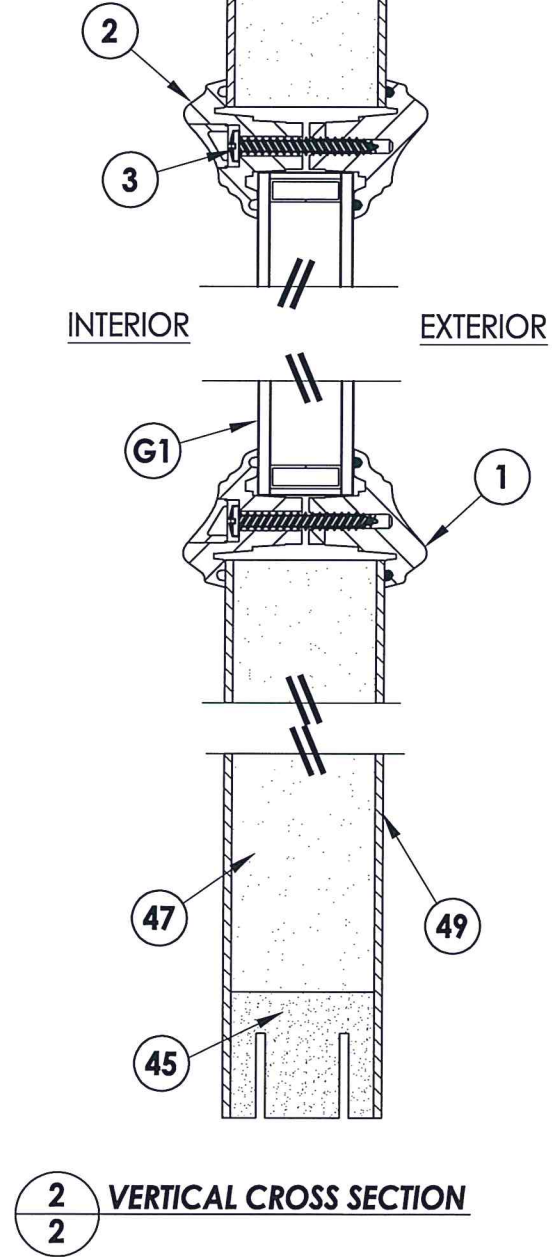
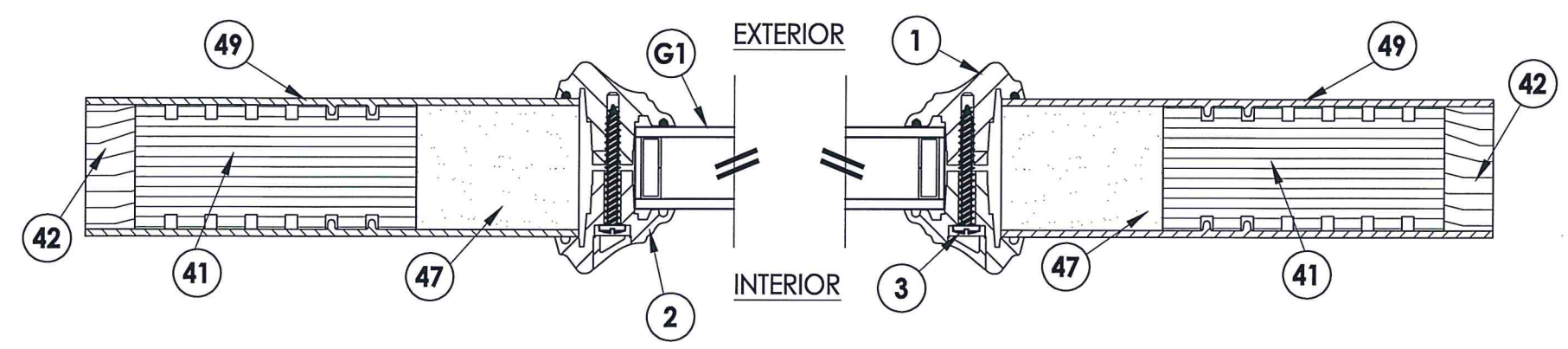

2 VERTICAL CROSS SECTION

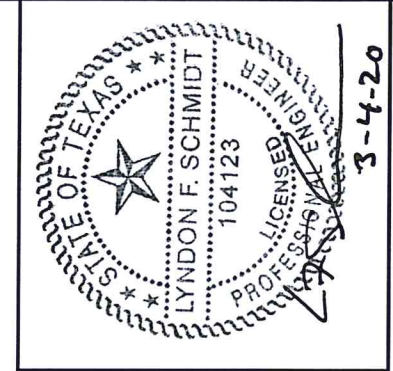

Documents Prepared By: Lyndon F. Schmidt, P.E.
TEXAS P.E. #104123

RW BUILDING CONSULTANTS, INC.
P.O. Box 230 Valrico FL 33595
Phone No.: 813.659.9197

TEXAS BOARD OF PROFESSIONAL ENGINEERS
CERTIFICATE OF REGISTRATION # F-11852

PRODUCT: MASTERGRAIN FIBERGLASS DOOR

PART OR ASSEMBLY: DOOR PANEL DETAILS AND GLAZING DETAIL

NO.	DATE	DESCRIPTION	BY
1	3/03/20	UPDATE TO 2018 IBC/IRC CODE	LFS
REVISIONS			

DATE: 01/04/10
SCALE: N.T.S.
DWG. BY: JK
CHK. BY: LFS
DRAWING NO.: TX-4044
SHEET 2 OF 10

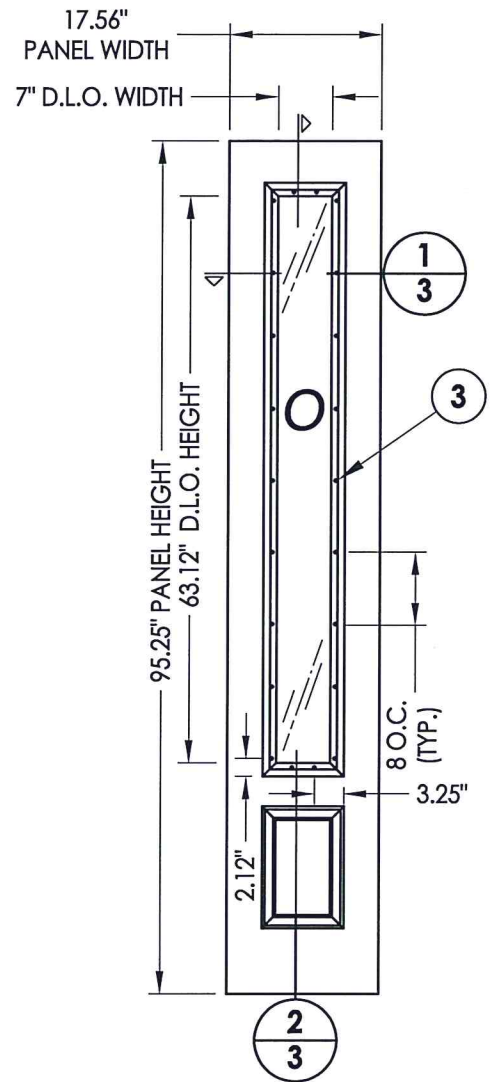

50 SIDELITE PANEL
Fiberglass

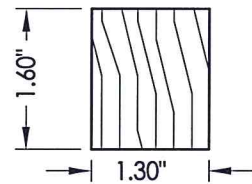

52 SIDELITE STILE
Wood

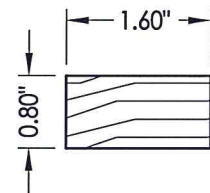

53 SIDELITE BOTTOM RAIL
Wood

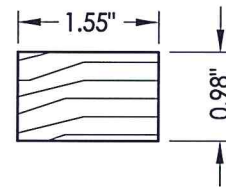

54 SIDELITE TOP RAIL
Wood

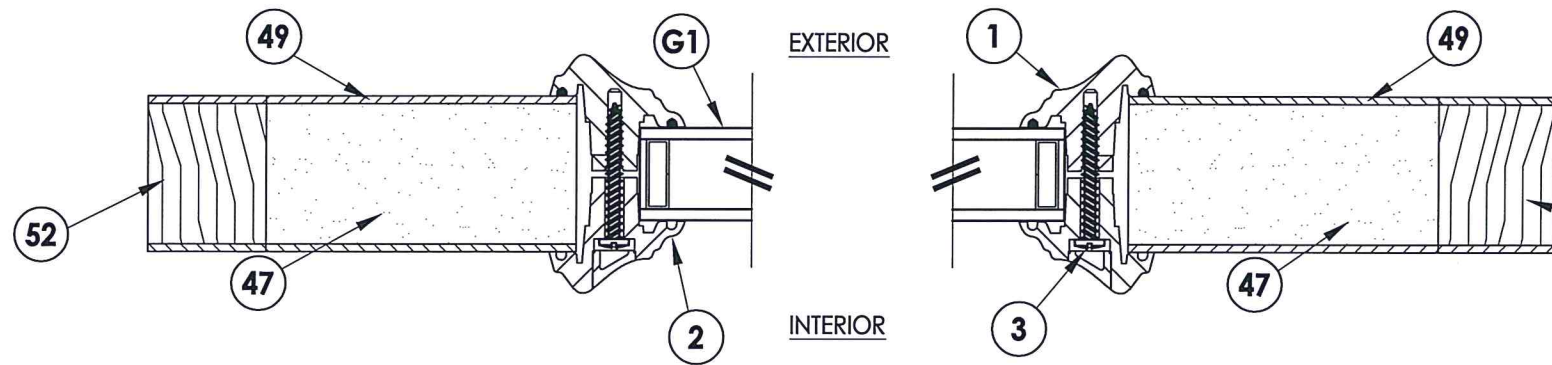

1 HORIZONTAL CROSS SECTION
3

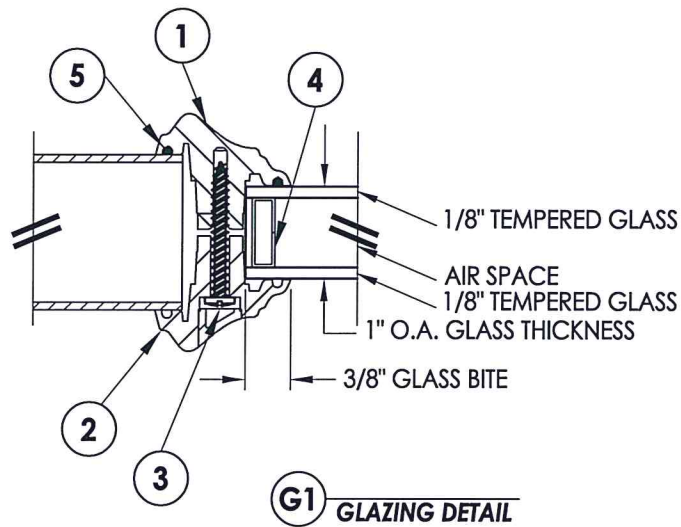

G1 GLAZING DETAIL

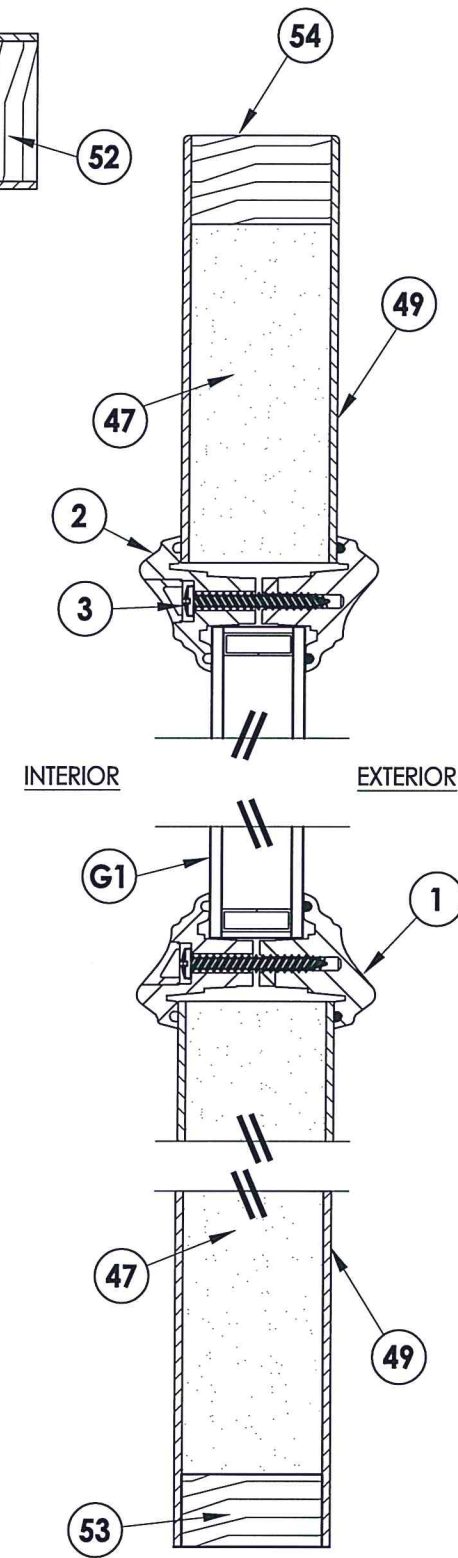

2 VERTICAL CROSS SECTION
3



Documents Prepared By: Lyndon F. Schmidt, P.E.
TEXAS P.E. #104123

RW BUILDING CONSULTANTS, INC.
P.O. Box 230 Valrico FL 33595
Phone No.: 813.659.9197
TEXAS BOARD OF PROFESSIONAL ENGINEERS
CERTIFICATE OF REGISTRATION # F-11852

PRODUCT: MASTERGRAIN
FIBERGLASS DOOR
PART OR ASSEMBLY:
SIDELITE PANEL DETAILS
AND GLAZING DETAIL

NO	DATE	DESCRIPTION	BY
1	3/03/20	UPDATE TO 2018 IBC/IRC CODE	LFS

DATE: 01/04/10
SCALE: N.T.S.
DWG. BY: JK
CHK. BY: LFS
DRAWING NO.: TX-4044
SHEET 3 OF 10

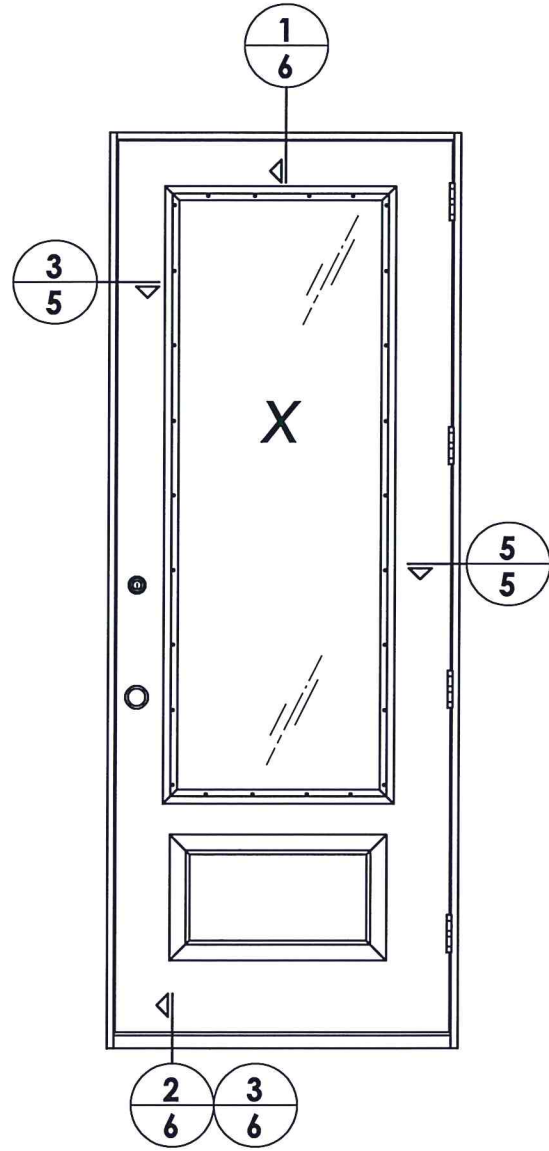

ELEVATION (X)

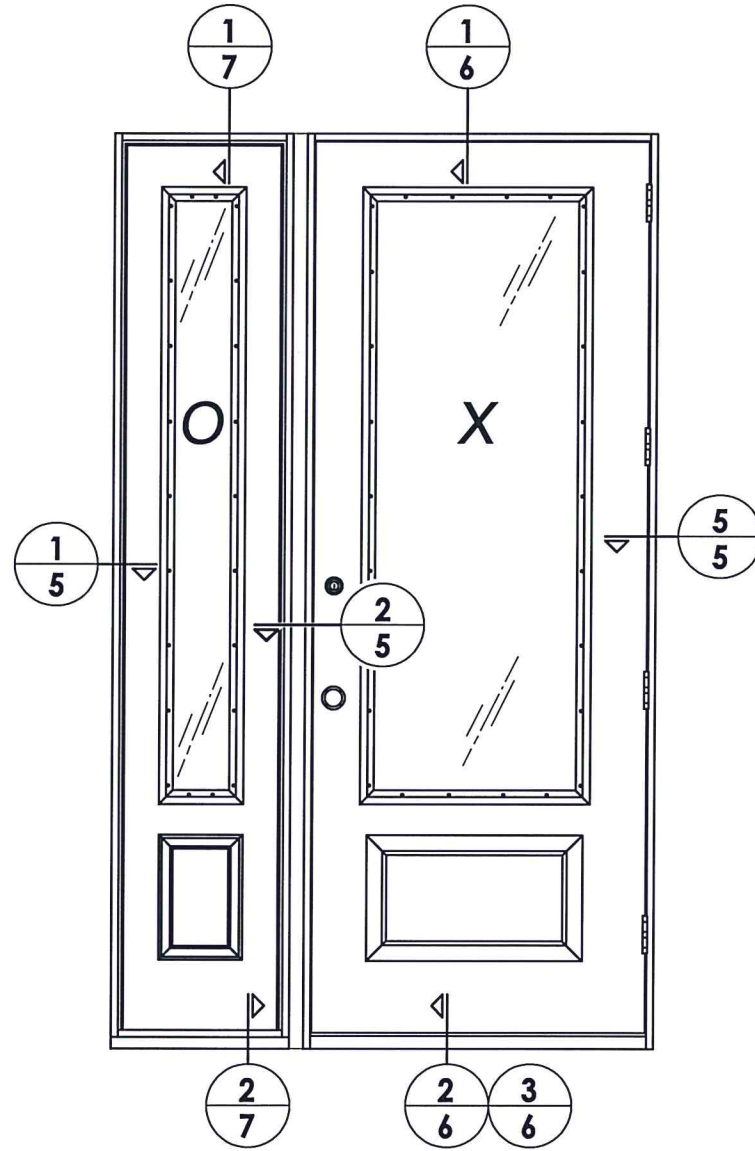

ELEVATION (OX / XO)

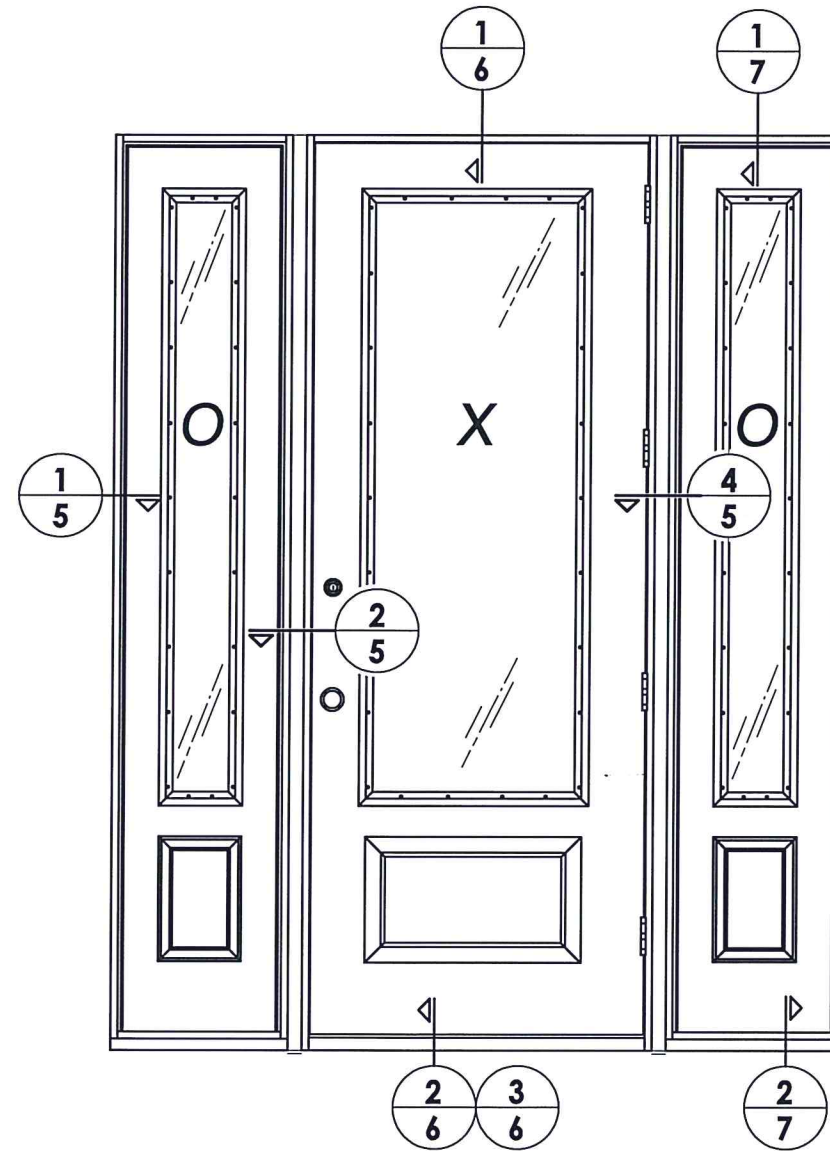

ELEVATION (OXO)

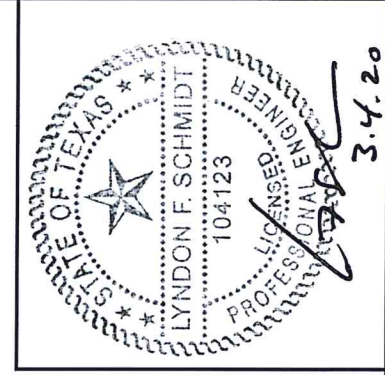

Documents Prepared By: Lyndon F. Schmidt, P.E.
TEXAS P.E. #104123

RW BUILDING CONSULTANTS, INC.
P.O. Box 230 Vairico FL. 33595
Phone No.: 813.659.9197

TEXAS BOARD OF PROFESSIONAL ENGINEERS
CERTIFICATE OF REGISTRATION # F-11852

PRODUCT: MASTERGRAIN FIBERGLASS DOOR
PART OR ASSEMBLY: ELEVATIONS

NO.	DATE	REVISIONS	BY
1	3/03/20	UPDATE TO 2018 IBC/IRC CODE	LFS

DATE: 01/04/10
SCALE: N.T.S.
DWG. BY: JK
CHK. BY: LFS
DRAWING NO.: TX-4044
SHEET 4 OF 10

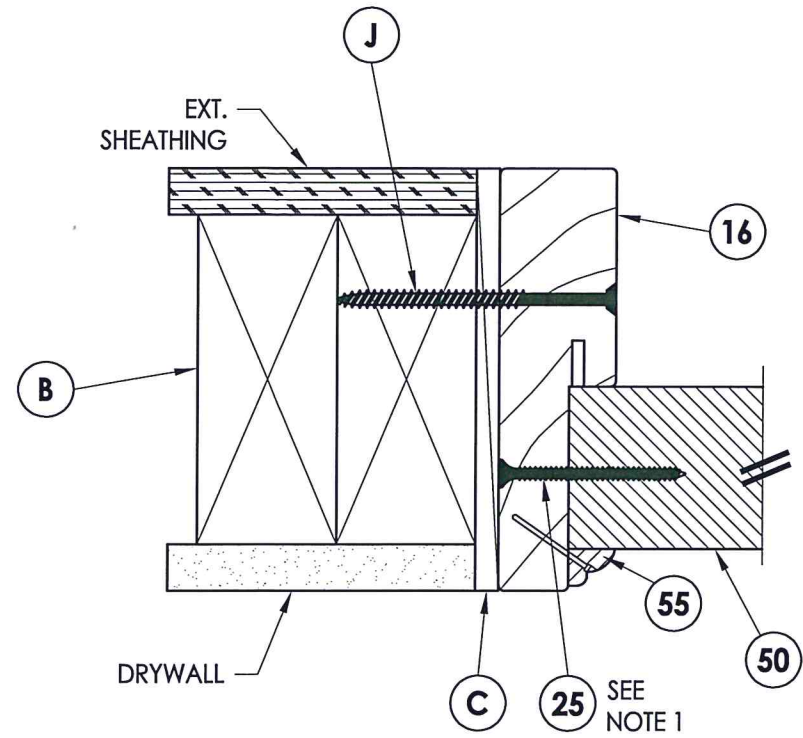

1
5 HORIZONTAL CROSS SECTION

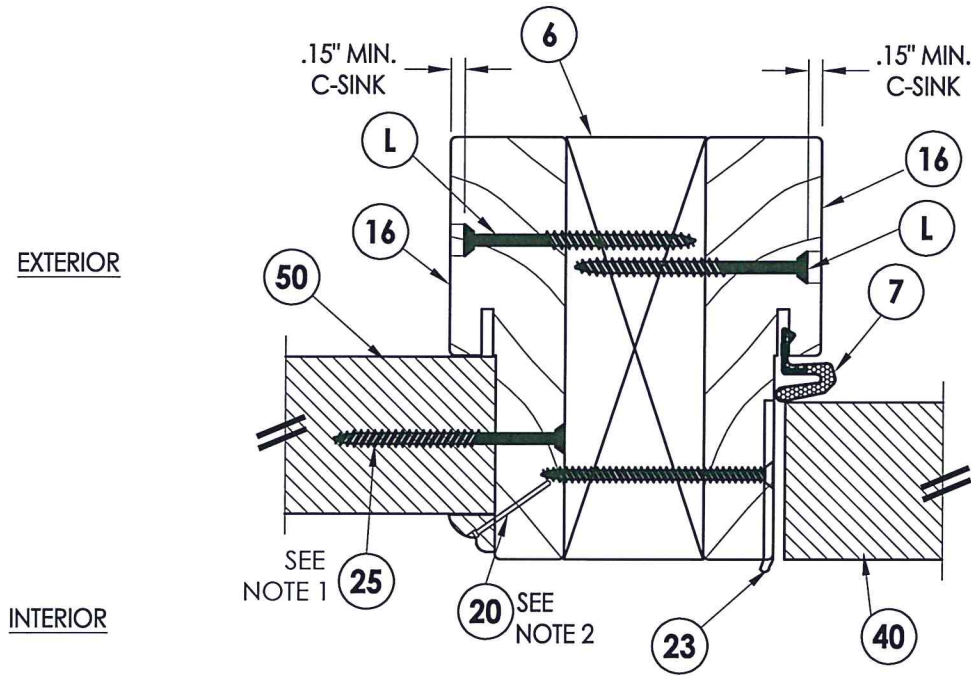

2
5 HORIZONTAL CROSS SECTION

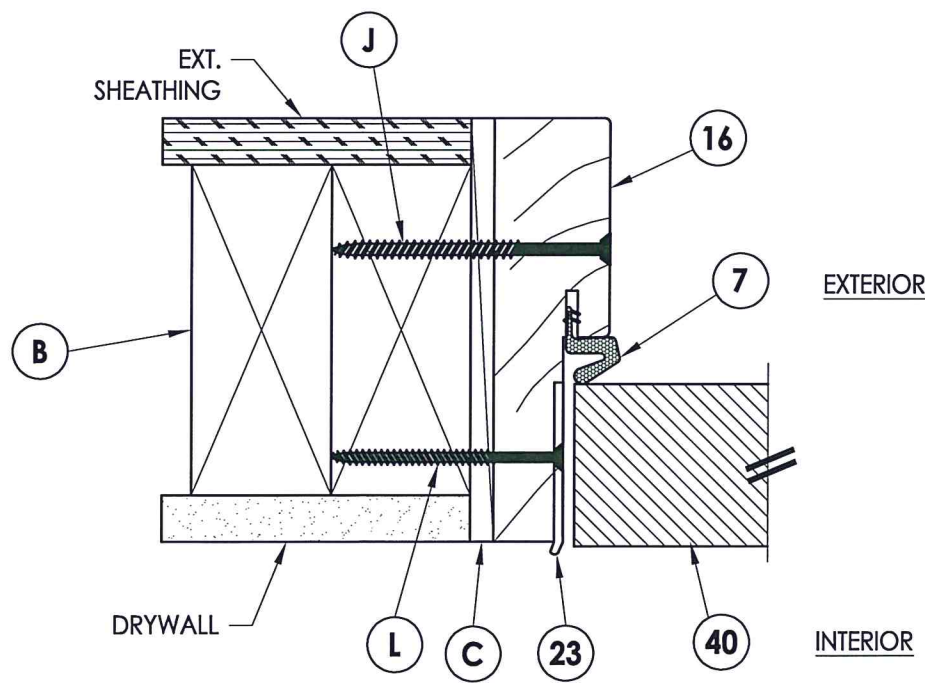

3
5 HORIZONTAL CROSS SECTION

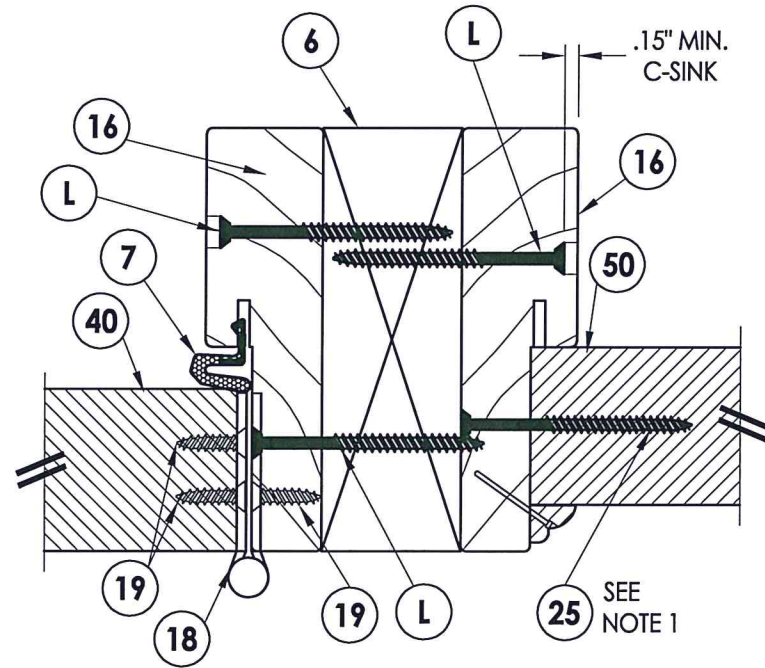

4
5 HORIZONTAL CROSS SECTION

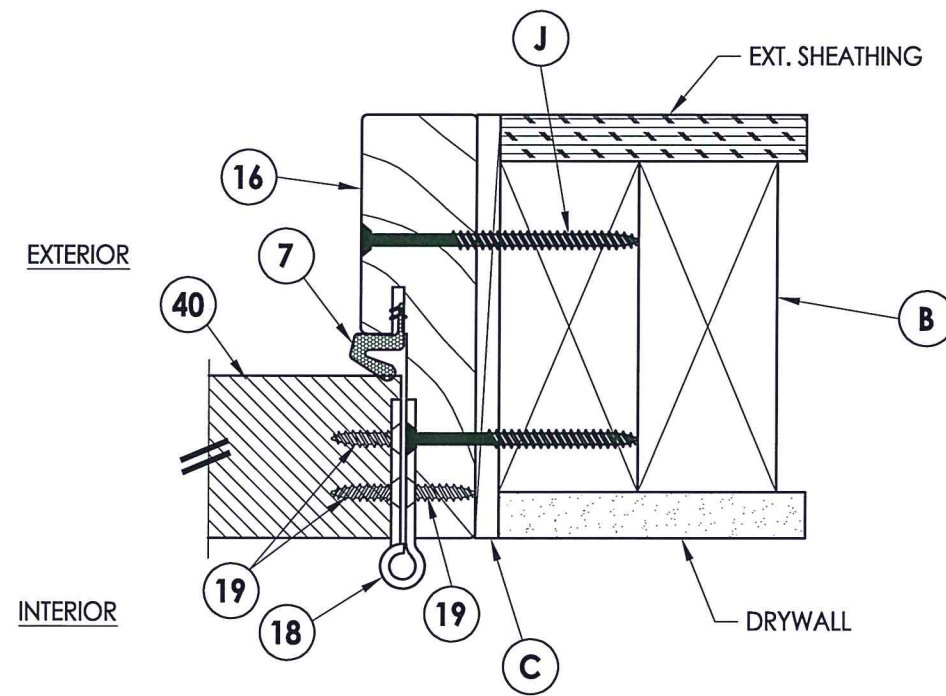

5
5 HORIZONTAL CROSS SECTION

NOTE:

1. Sidelite ass'y fastener; 6" from each end and 6 more screws equally spaced between. (8 screws total per jamb.)
2. Trim secured with 1" Brad Nail @ 6" O.C. (TYP).

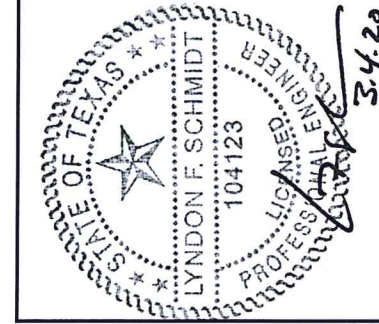

Documents Prepared By: Lyndon F. Schmidt, P.E.
TEXAS P.E. #104123

RW BUILDING CONSULTANTS, INC.
P.O. Box 230 Valrico FL, 33595
Phone No.: 813.659.9197

TEXAS BOARD OF PROFESSIONAL ENGINEERS
CERTIFICATE OF REGISTRATION # F-11852

PRODUCT: MASTERGRAIN FIBERGLASS DOOR
PART OR ASSEMBLY: HORIZONTAL CROSS SECTIONS

NO.	DATE	BY	REVISIONS
1	3/03/20	LFS	UPDATE TO 2018 IBC/IRC CODE

DATE: 01/04/10
SCALE: N.T.S.
DWG. BY: JK
CHK. BY: LFS
DRAWING NO.: TX-4044
SHEET 5 OF 10

R:\Clients\Mastergrain PERMANENT\B - Texas Dept of Ins\TDI - DR 422,423 Fiberglass Door\Drawings\TX 4044-4047.dwg, 6-44

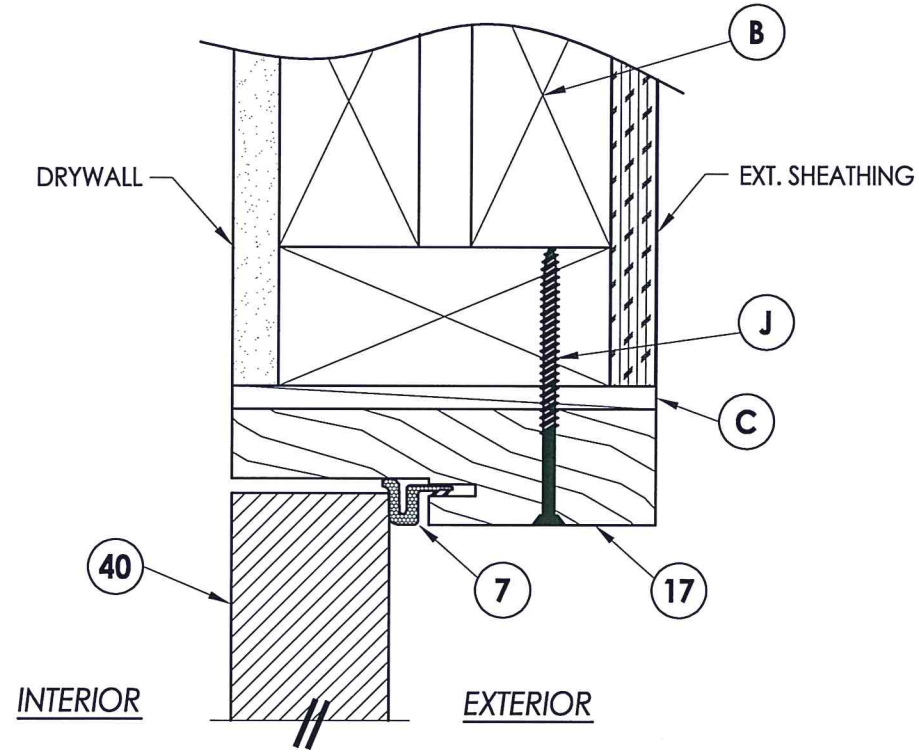

1
6 VERTICAL CROSS SECTION

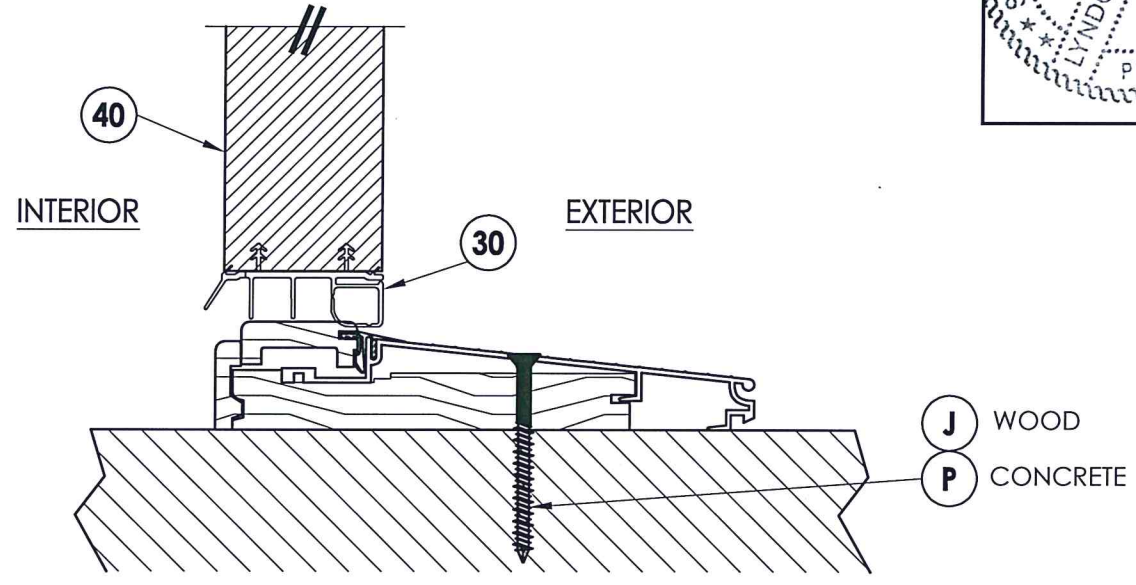

2
6 VERTICAL CROSS SECTION
Inswing configuration

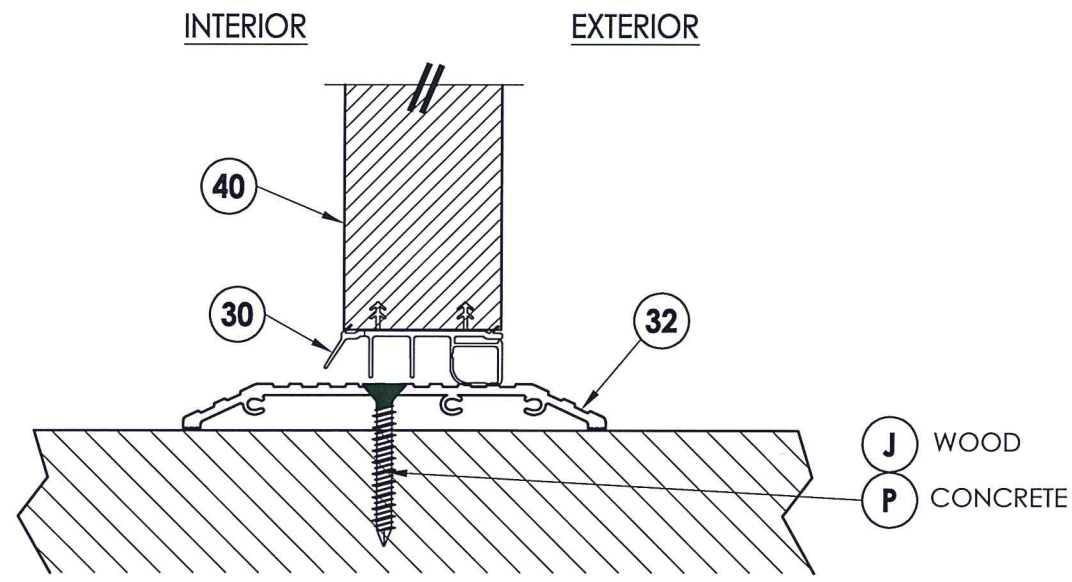

3
6 VERTICAL CROSS SECTION
Shown w/ ADA threshold

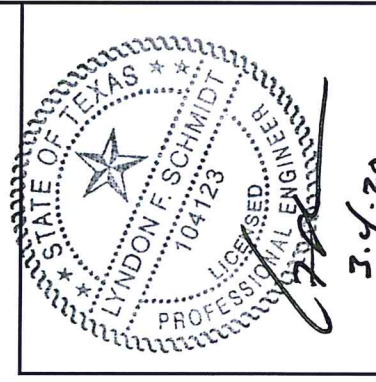

Documents Prepared By: Lyndon F. Schmidt, P.E.
TEXAS P.E. #104123

RW BUILDING CONSULTANTS, INC.
P.O. Box 230 Valrico FL 33595
Phone No.: 813.659.9197

TEXAS BOARD OF PROFESSIONAL ENGINEERS
CERTIFICATE OF REGISTRATION # F-11852

PRODUCT:	MASTERGRAIN FIBERGLASS DOOR	
PART OR ASSEMBLY:	VERTICAL CROSS SECTIONS	
NO.	DATE	REVISIONS
1	3/03/20	UPDATE TO 2018 IBC/IRC CODE
		LFS
		BY
DATE: 01/04/10		
SCALE: N.T.S.		
DWG. BY: JK		
CHK. BY: LFS		
DRAWING NO.: TX-4044		
SHEET 6 OF 10		

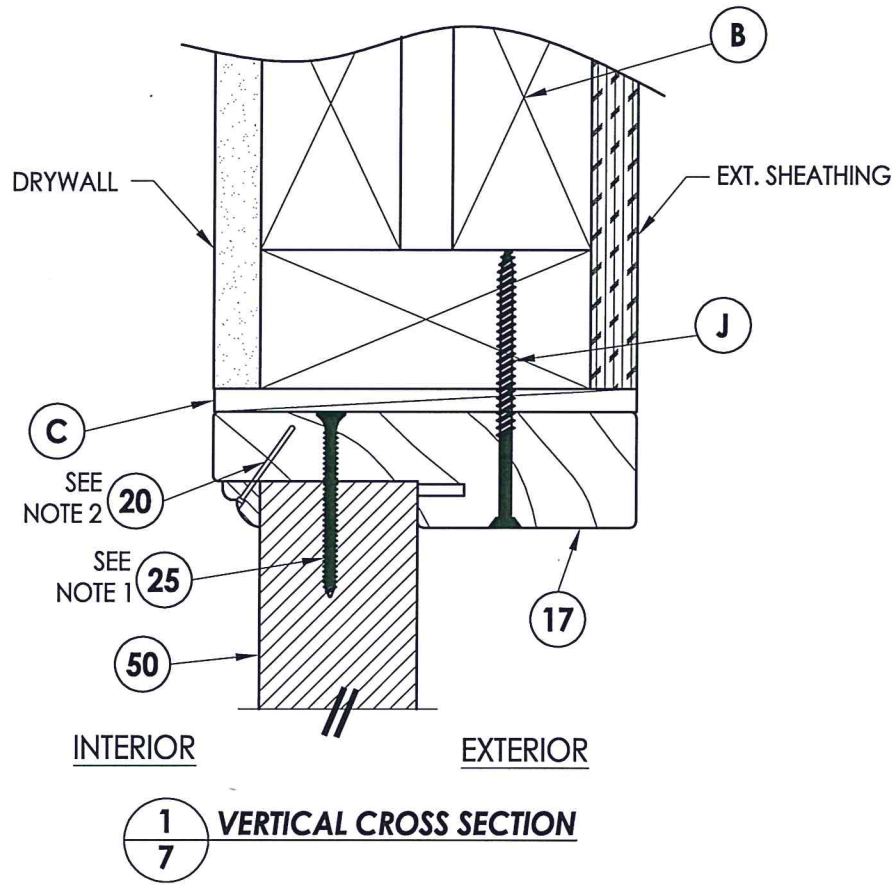
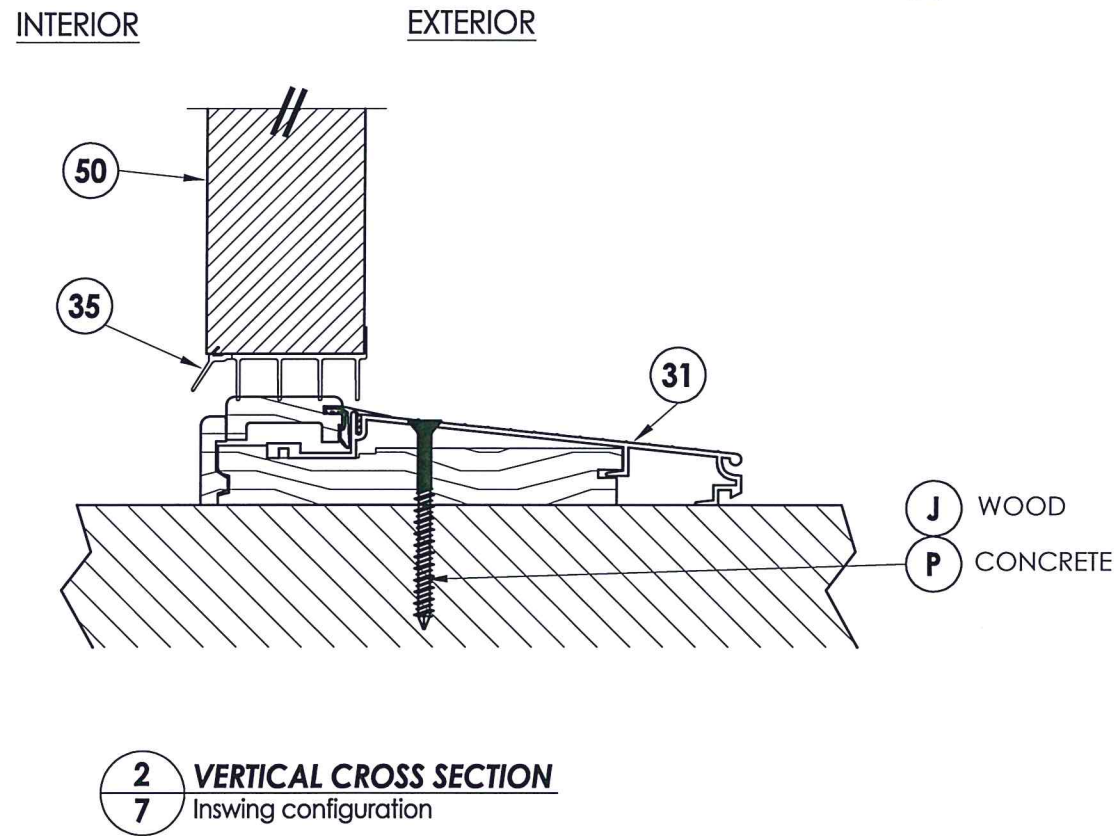

NOTE:

1. Screws thru head jamb located 3" from each end.
2. Trim secured with 1" Brad Nail @ 6" O.C. (TYP).

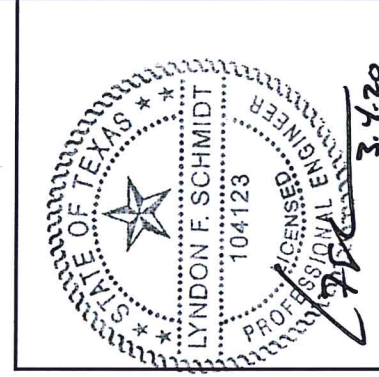

Documents Prepared By: Lyndon F. Schmidt, P.E.
TEXAS P.E. #104123

RW BUILDING CONSULTANTS, INC.
P.O. Box 230 Valrico FL, 33595
Phone No.: 813.659.9197
TEXAS BOARD OF PROFESSIONAL ENGINEERS
CERTIFICATE OF REGISTRATION # F-11852

PRODUCT:	MASTERGRAIN FIBERGLASS DOOR
PART OR ASSEMBLY:	VERTICAL CROSS SECTIONS

REVISIONS	
NO.	DATE
1	3/03/20
	UPDATE TO 2018 IBC/IRC CODE
	LFS
	BY

DATE:	01/04/10
SCALE:	N.T.S.
DWG. BY:	JK
CHK. BY:	LFS
DRAWING NO.:	TX-4044
SHEET	7 OF 10

R:\Clients\Mastergrain PERMANENT\B - Texas Dept of Ins\TDI - DR 422 Fiberglass Door\Drawings\TX 4044-4047.dwg, 8-44

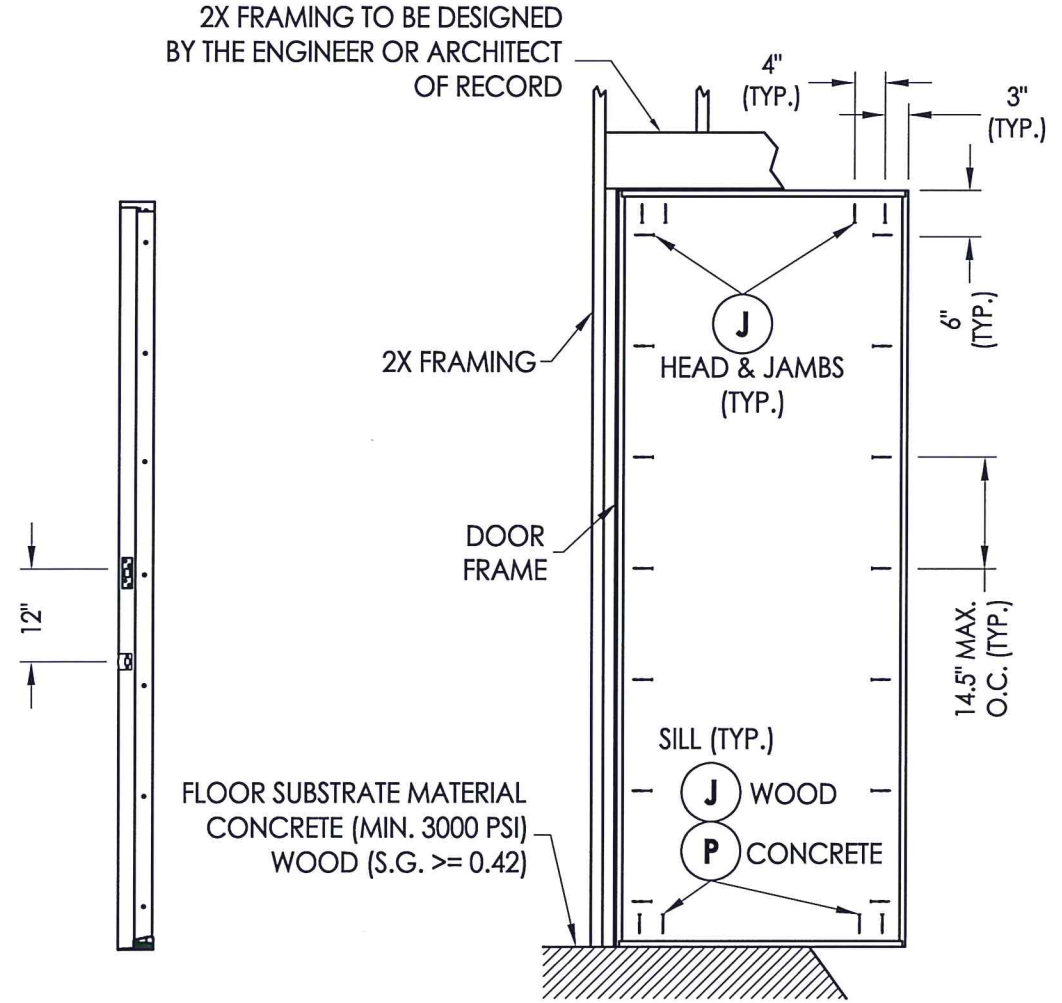

STRIKE JAMB

FRAME ANCHORING
Stud construction

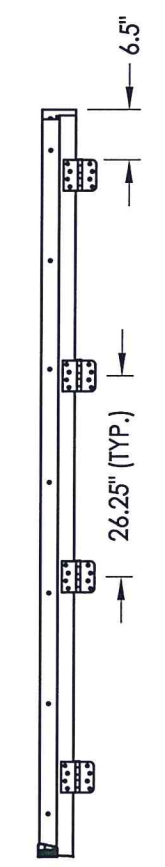

HINGE JAMB

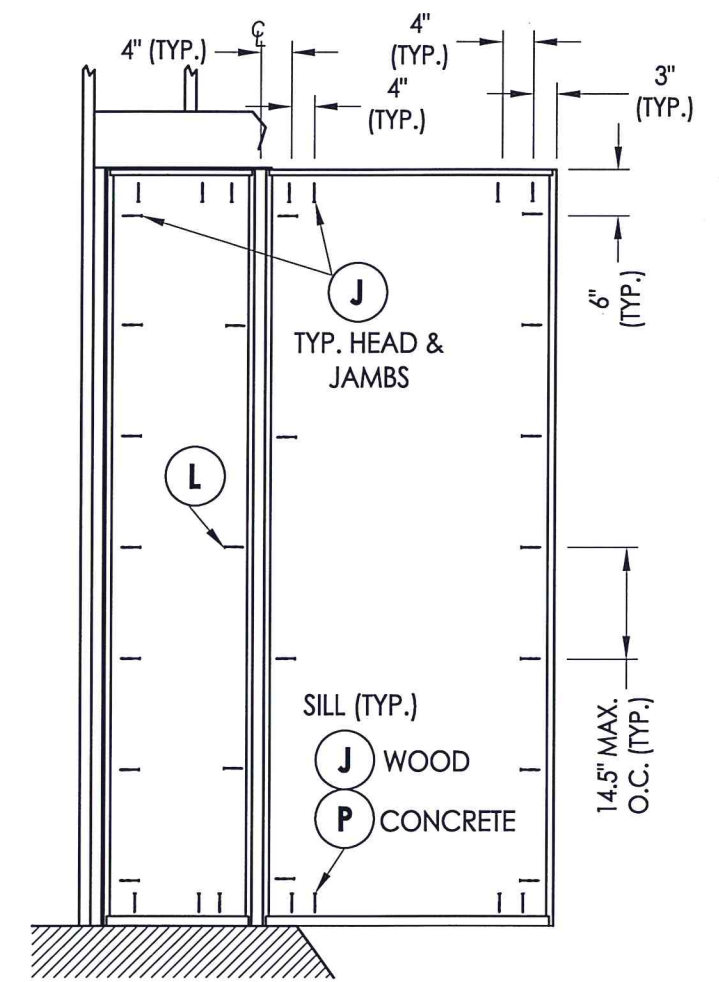

FRAME ANCHORING
Masonry construction

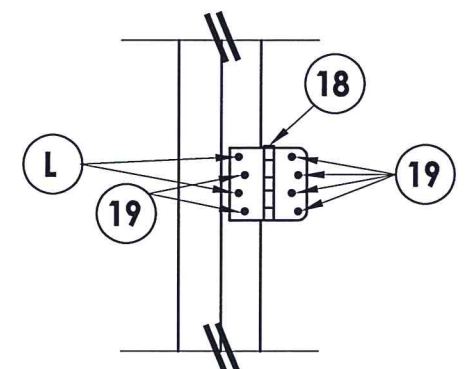

HINGE DETAIL

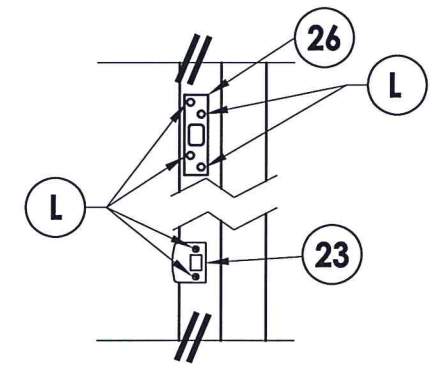

LATCH & DEADBOLT DETAIL
SECURITY STRIKE

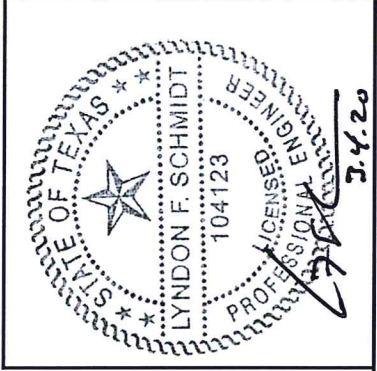

Documents Prepared By: Lyndon F. Schmidt, P.E.
TEXAS P.E. #104123

RW BUILDING CONSULTANTS, INC.
P.O. Box 230 Valrico FL, 33595
Phone No.: 813.659.9197

TEXAS BOARD OF PROFESSIONAL ENGINEERS
CERTIFICATE OF REGISTRATION # F-11852

PRODUCT:	MASTERGRAIN FIBERGLASS DOOR
PART OR ASSEMBLY:	FRAME ANCHORING

NO.	DATE	DESCRIPTION	BY
1	3/03/20	UPDATE TO 2018 IBC/IRC CODE	LFS

DATE:	01/04/10
SCALE:	N.T.S.
DWG. BY:	JK
CHK. BY:	LFS
DRAWING NO.:	TX-4044
SHEET	8 of 10

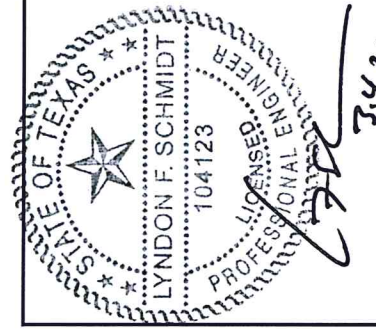
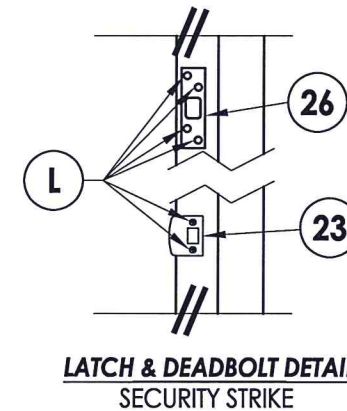
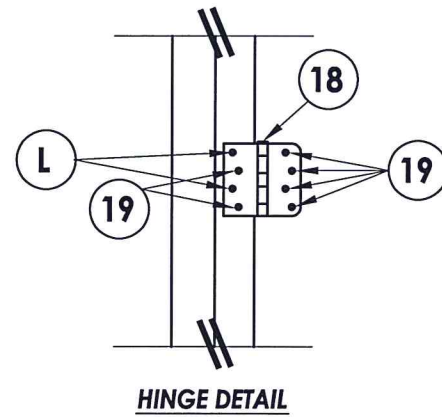
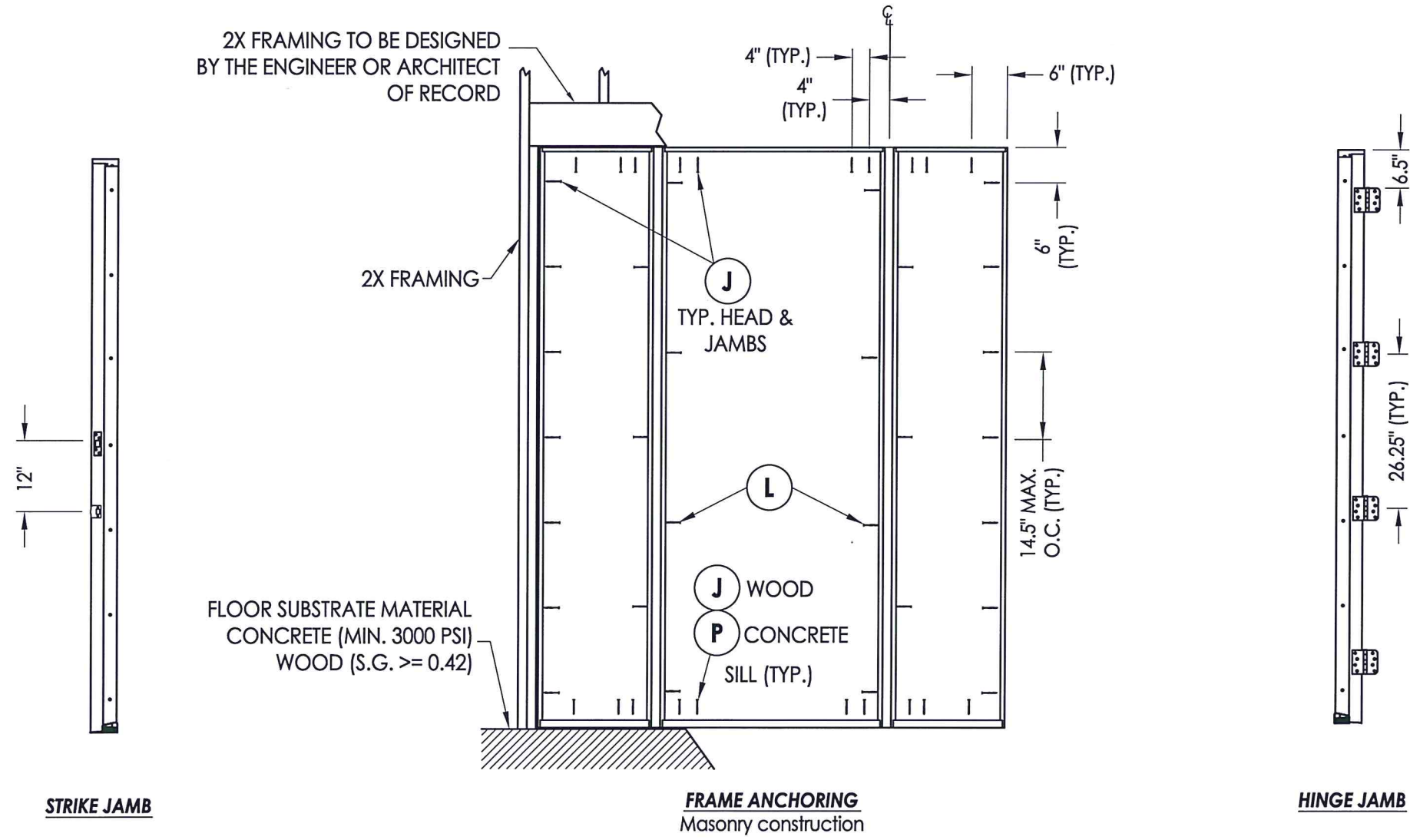

Documents Prepared By: Lyndon F. Schmidt, P.E.
TEXAS P.E. #104123

RW BUILDING CONSULTANTS, INC.
P.O. Box 230 Valrico FL, 33595
Phone No.: 813.659.9197

TEXAS BOARD OF PROFESSIONAL ENGINEERS
CERTIFICATE OF REGISTRATION # F-11852

PRODUCT: MASTERGRAIN FIBERGLASS DOOR

PART OR ASSEMBLY: FRAME ANCHORING

NO.	DATE	DESCRIPTION	BY
1	3/03/20	UPDATE TO 2018 IBC/IRC CODE	LFS

DATE: 01/04/10

SCALE: N.T.S.

DWG. BY: JK

CHK. BY: LFS

DRAWING NO.: TX-4044

SHEET 9 OF 10

BILL OF MATERIALS		
ITEM #	DESCRIPTION	MATERIAL
B	2X FRAMING SG >= 0.42	WOOD
C	1/4" MAX. SHIM SPACE	-
J	#10 X 3" PFH WS	STEEL
K	#9 X 2-1/2" PFH WS	STEEL
L	#10 X 2-1/2" PFH WOOD SCREW	STEEL
P	3/16" ELCO OR ITW PFH CONCRETE SCREW	STEEL
1	FEMALE LITE FRAME - MASTERGRAIN	POLYPROPYLENE
2	MALE LITE FRAME - MASTERGRAIN	POLYPROPYLENE
3	#8 X 1-3/4" PANHEAD SMS (LIGHT FRAME SCREW)	STEEL
4	ALUMINUM SPACER SYSTEM	ALUMINUM
5	SILICONE WEATHER SEAL MG #2500	SILICONE
6	2X MULLION SG > = 0.55	WOOD
7	WEATHER STRIP	FOAM
8	#10 X 1-1/2" PFH	STEEL
16	SIDE JAMB SG > = 0.42	WOOD
17	HEAD JAMB SG > = 0.42	WOOD
18	4" X 4" HINGE MIN 0.1" THICK	STEEL
19	#10 X 3/4" PFH WS	STEEL
20	1" BRAD NAIL	STEEL
21	KWIKSET DEADBOLT -SERIES 690 CP	STEEL
21A	COPPER CREEK DB2410 SC #8003 DEADBOLT	STEEL
22	KWIKSET LOCK -SERIES 690 CP PASSAGE	STEEL
22A	COPPER CREEK BK2040 SC# 8379 PASSAGE	STEEL

23	LATCH STRIKE PLATE	STEEL
24	DEADBOLT STRIKE PLATE	STEEL
25	#8 X 2-1/2" PFH WOOD SCREW	STEEL
26	SECURITY STRIKE PLATE	STEEL
30	DOOR BOTTOM SWEEP	VINYL
31	INSWING THRESHOLD	ALUM/COMP.
32	ADA THRESHOLD	ALUM.
34	SIDELITE THRESHOLD	ALUM./COMP.
35	SIDELITE SWEEP	VINYL
40	DOOR PANEL - SEE DOOR PANEL DETAIL SHEET FOR CONSTRUCTION DETAILS	-
41	HINGE AND LATCH REINFORCMENT	WOOD
42	HINGE AND LATCH STILE - SG >= 0.42	WOOD
44	TOP RAIL	COMP.
45	BOTTOM RAIL	COMP.
47	POLYURETHANE FOAM	POLYURETHANE
49	FIBERGLASS SKIN 0.08" MIN. THICKNESS	FIBERGLASS
50	SIDELITE PANEL - SEE SIDELITE PANEL DETAIL SHEET FOR CONSTRUCTION DETAILS	-
52	SIDELITE STILE - SG >= 0.42	WOOD
53	SIDELITE BOTTOM RAIL SG > = 0.42	WOOD
54	SIDELITE TOP RAIL SG > = 0.42	WOOD
55	SIDELITE TRIM	WOOD

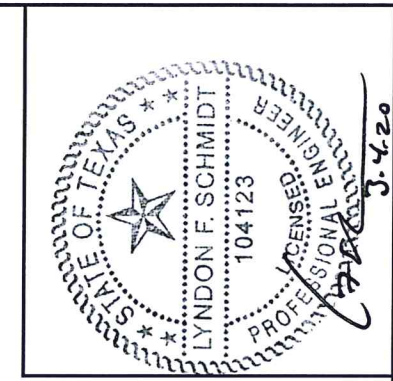

Documents Prepared By: Lyndon F. Schmidt, P.E.
TEXAS P.E. #104123

RW BUILDING CONSULTANTS, INC.
P.O. Box 230 Valrico FL 33595
Phone No.: 813.659.9197

TEXAS BOARD OF PROFESSIONAL ENGINEERS
CERTIFICATE OF REGISTRATION # F-11852

PRODUCT: MASTERGRAIN FIBERGLASS DOOR

PART OR ASSEMBLY: BILL OF MATERIALS

NO.	DATE	UPDATE TO 2018 IBC/IRC CODE	LFS	BY
1	3/03/20			

REVISIONS

DATE: 01/04/10
SCALE: N.T.S.
DWG. BY: JK
CHK. BY: LFS
DRAWING NO.: TX-4044
SHEET 10 OF 10

CONCRETE ANCHOR NOTES:

- Concrete anchor locations at the corners may be adjusted to maintain the min. edge distance to mortar joints.
- Concrete anchor locations noted as "MAX. ON CENTER" must be adjusted to maintain the min. edge distance to mortar joints, additional concrete anchors may be required to ensure the "MAX. ON CENTER" dimension are not exceeded.
- Concrete anchor table:

ANCHOR TYPE	ANCHOR SIZE	MIN. EMBEDMENT	MIN. CLEARANCE TO MASONRY EDGE	MIN. CLEARANCE TO ADJACENT ANCHOR
ITW TAPCON®	1/4"	1-3/4"	1-1/2"	4"
ELCO ULTRACON®	1/4"	1-3/4"	1"	4"

