

THERMA TRU®

118 INDUSTRIAL DR., EDGERTON, OH 43517
TEL. (419)298-1740

SMOOTH STAR, FIBER CLASSIC, CLASSIC CRAFT & CLASSIC CRAFT RUSTIC SINGLE "IMPACT" DOOR WITH "NON-IMPACT" SIDELITE IN SWING / OUTSWING

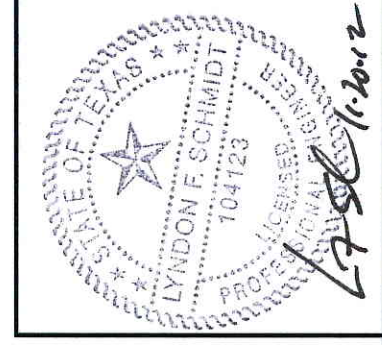

Documents Prepared By: Lyndon F. Schmidt, P.E.
TEXAS P.E. #104123

RW BUILDING CONSULTANTS, INC.
P.O. Box 230 Vairico FL 33595
Phone No.: 813.659.9197

TEXAS BOARD OF PROFESSIONAL ENGINEERS
CERTIFICATE OF REGISTRATION # F-11852

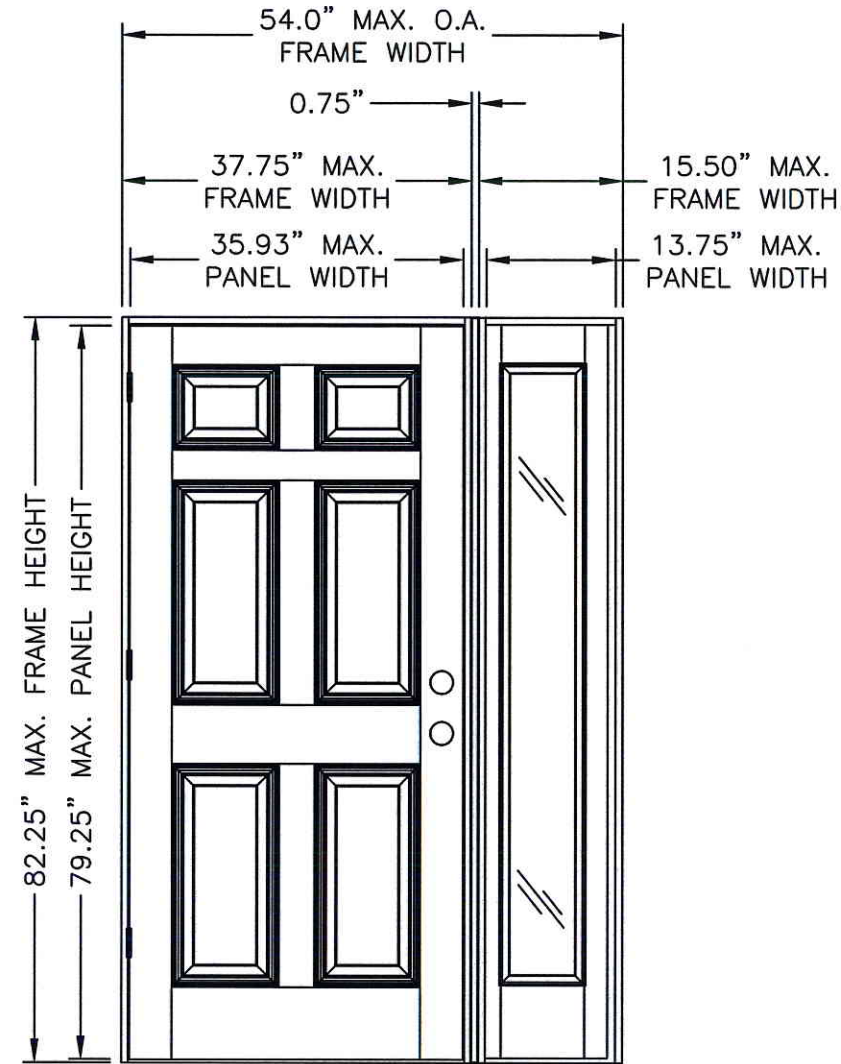

"SMOOTH STAR", "CLASSIC CRAFT", "CLASSIC CRAFT RUSTIC" & "FIBER CLASSIC"

EVALUATED FOR USE IN THE STATE OF TEXAS

The Fiberglass Opaque Door described herein complies with the 2006 International Residential Code (IRC), Sections R301 & R613 and the 2006 International Building Code (IBC), Sections 1405.12, 1609, 1714.5, 2403 and 2404 (including Texas revisions) subject to the following conditions:

1. Anchors shall be as listed and spaced as shown in the details. Anchor embedment to base material shall be beyond wall dressing or stucco.
2. The opaque door has been tested and evaluated as a large missile impact protective system for installation in the Seaward, Inland I and Inland II areas. The opaque door meets missile level "D" as defined in ASTM E 1996. The non-impact sidelites require an impact protective system when installed in the Seaward, Inland I and Inland II areas.
3. Allowable design pressure requirements must be equal to or less than the design pressure rating shown in the design pressure chart, sheet 1 of this drawing.
4. Conditions not covered by this drawing are subject to further engineering analysis.

PRODUCT: SINGLE OPAQUE
FIBERGLASS DOOR W/SIDELITE
"IMPACT" IN SWING / OUTSWING
PART OR ASSEMBLY:

TYPICAL ELEVATIONS, DESIGN PRESSURES & GENERAL NOTES

NO.	DATE	BY	REVISIONS

DATE: 07/17/12
SCALE: N.T.S.
DWG. BY: JK
CHK. BY: LFS
DRAWING NO.: TX-4186
SHEET 1 OF 12

TABLE OF CONTENTS	
SHEET #	DESCRIPTION
1	TYPICAL ELEVATIONS, DESIGN PRESSURES & GENERAL NOTES
2	DOOR PANEL DETAILS (SMOOTH STAR)
3	DOOR PANEL DETAILS (CLASSIC CRAFT)
4	DOOR PANEL DETAILS (CLASSIC CRAFT RUSTIC)
5	DOOR PANEL DETAILS (FIBER CLASSIC)
6	SIDELITE PANEL DETAILS
7	HORIZONTAL CROSS SECTIONS
8	VERTICAL CROSS SECTIONS
9	VERTICAL CROSS SECTIONS
10	FRAME ANCHORING
11	COMPONENTS
12	BILL OF MATERIALS & GLAZING DETAILS

DOOR TYPE	SWING	OVERALL FRAME DIMENSION	OVERALL SIDELITE D.L.O. DIMENSION	DESIGN PRESSURE	
				POSITIVE	NEGATIVE
CLASSIC CRAFT	OUTSWING	54.0" X 80.75"	7.09" X 63.09"	+65.0	-65.0
	IN SWING	54.0" X 82.25"		+65.0	-65.0
FIBER CLASSIC	OUTSWING	54.0" X 80.75"		+65.0	-65.0
	IN SWING	54.0" X 82.25"		+65.0	-65.0
SMOOTH STAR	OUTSWING	54.0" X 80.75"		+65.0	-65.0
	IN SWING	54.0" X 82.25"		+65.0	-65.0
CLASSIC CRAFT RUSTIC	OUTSWING	54.0" X 80.75"		+65.0	-65.0
	IN SWING	54.0" X 82.25"		+65.0	-65.0

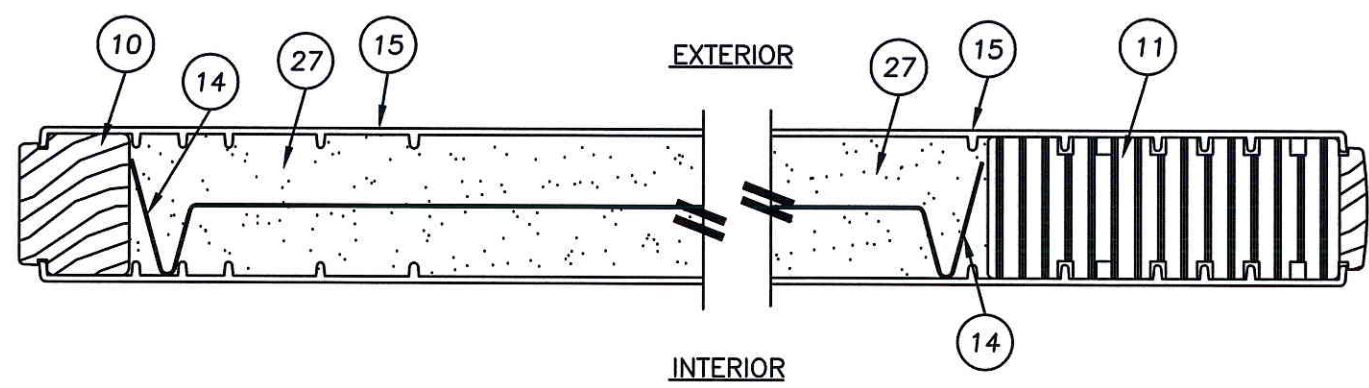
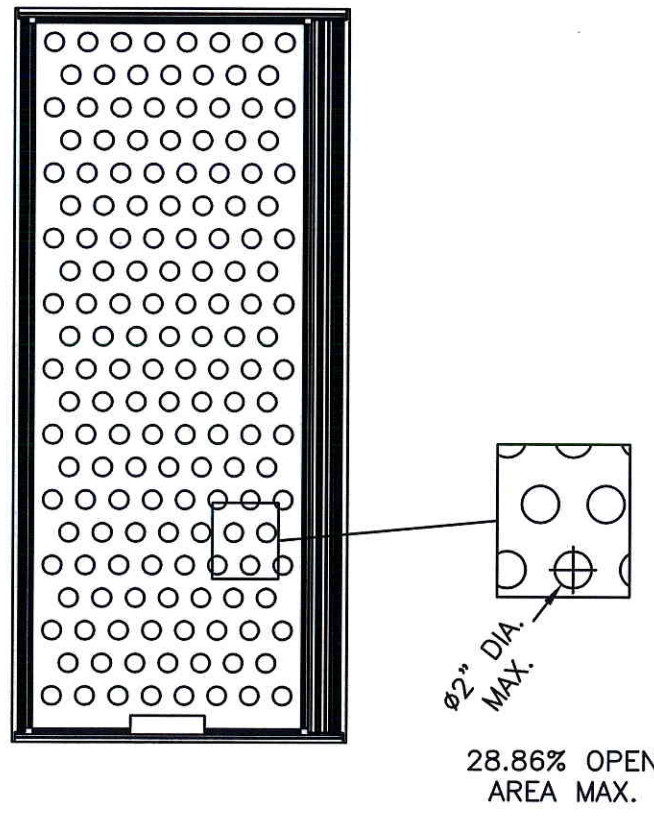
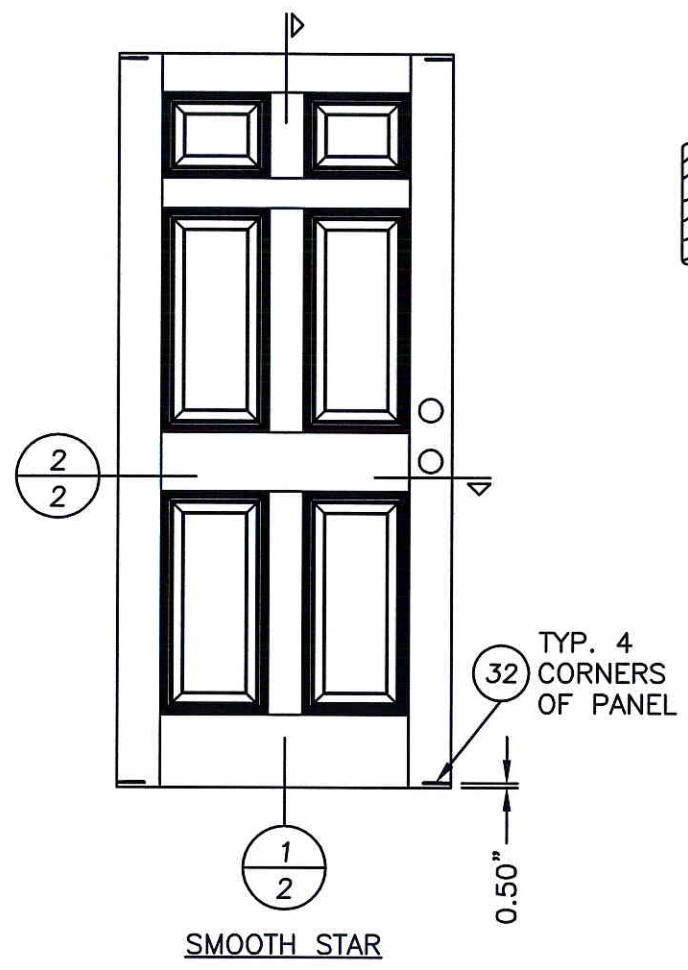

2 HORIZONTAL CROSS SECTION
2 SMOOTH STAR

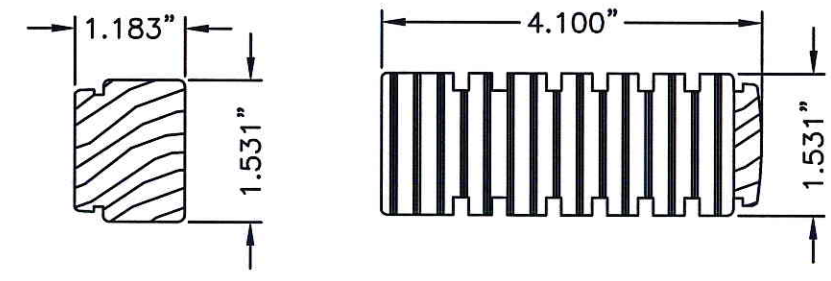

10 HINGE STILE SMOOTH STAR
11 LOCK STILE SMOOTH STAR

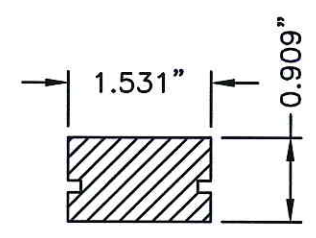

12 TOP RAIL SMOOTH STAR

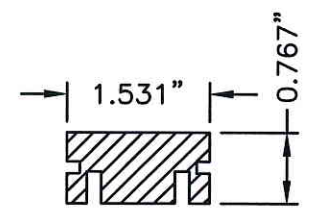

13 BOTTOM RAIL SMOOTH STAR

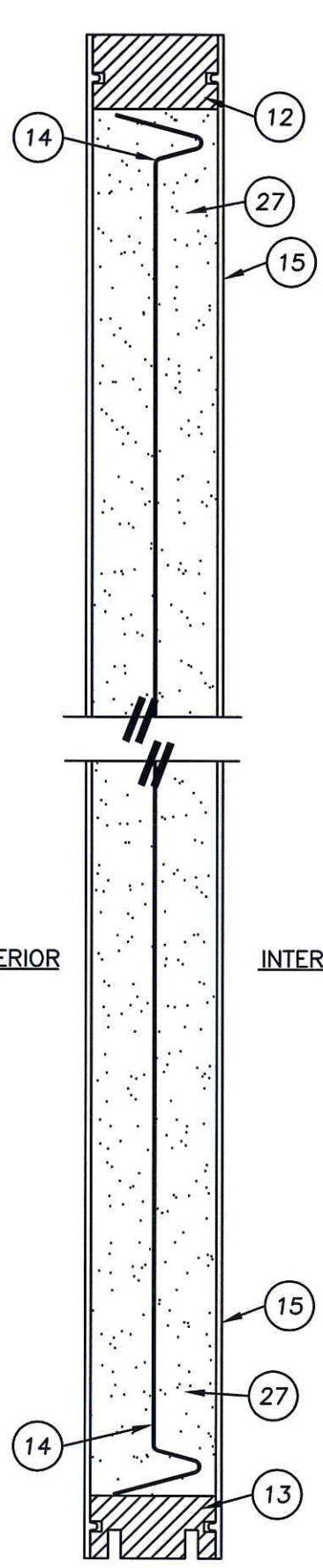

1 VERTICAL CROSS SECTION
2 SMOOTH STAR

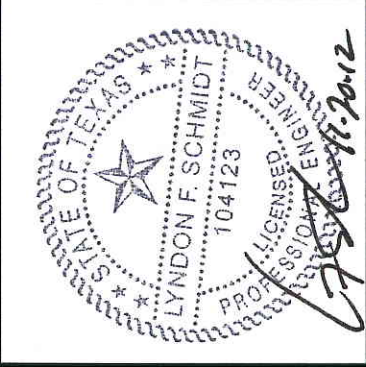

Documents Prepared By: Lyndon F. Schmidt, P.E.
TEXAS P.E. #104123

RW BUILDING CONSULTANTS, INC.
P.O. Box 230 Valrico FL 33595
Phone No.: 813.659.9197

TEXAS BOARD OF PROFESSIONAL ENGINEERS
CERTIFICATE OF REGISTRATION # F-11852

PRODUCT: SINGLE OPAQUE
FIBERGLASS DOOR W/ SIDELITE
"IMPACT" INSWING / OUTSWING
PART OR ASSEMBLY:
DOOR PANEL DETAILS
(SMOOTH STAR)

NO.	DATE	BY

DATE: 07/17/12
SCALE: N.T.S.
DWG. BY: JK
CHK. BY: LFS
DRAWING NO.: TX-4186
SHEET 2 OF 12

R:\A - Projects\Project Folders\Proj 1101 - 1200\pf1103\103.D. RWBC Drawings\CLASSIC CRAFT.dwg, FOX

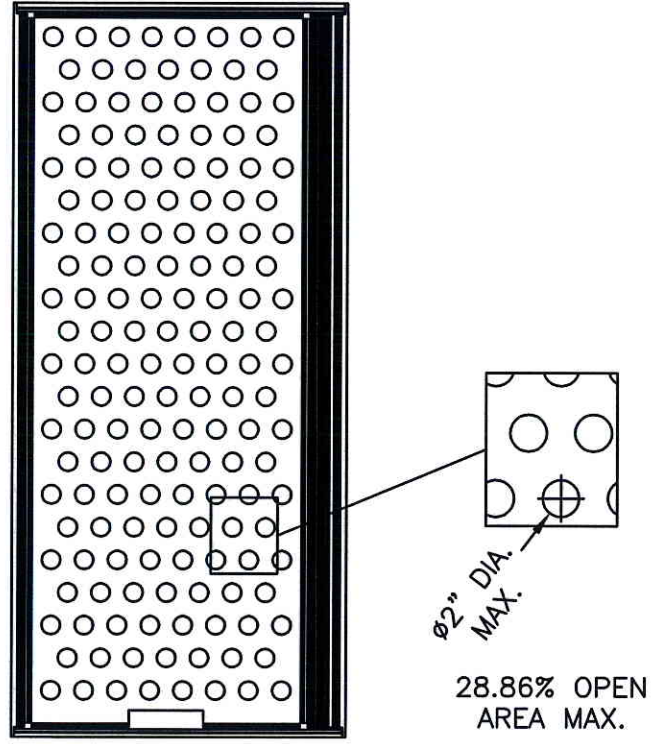
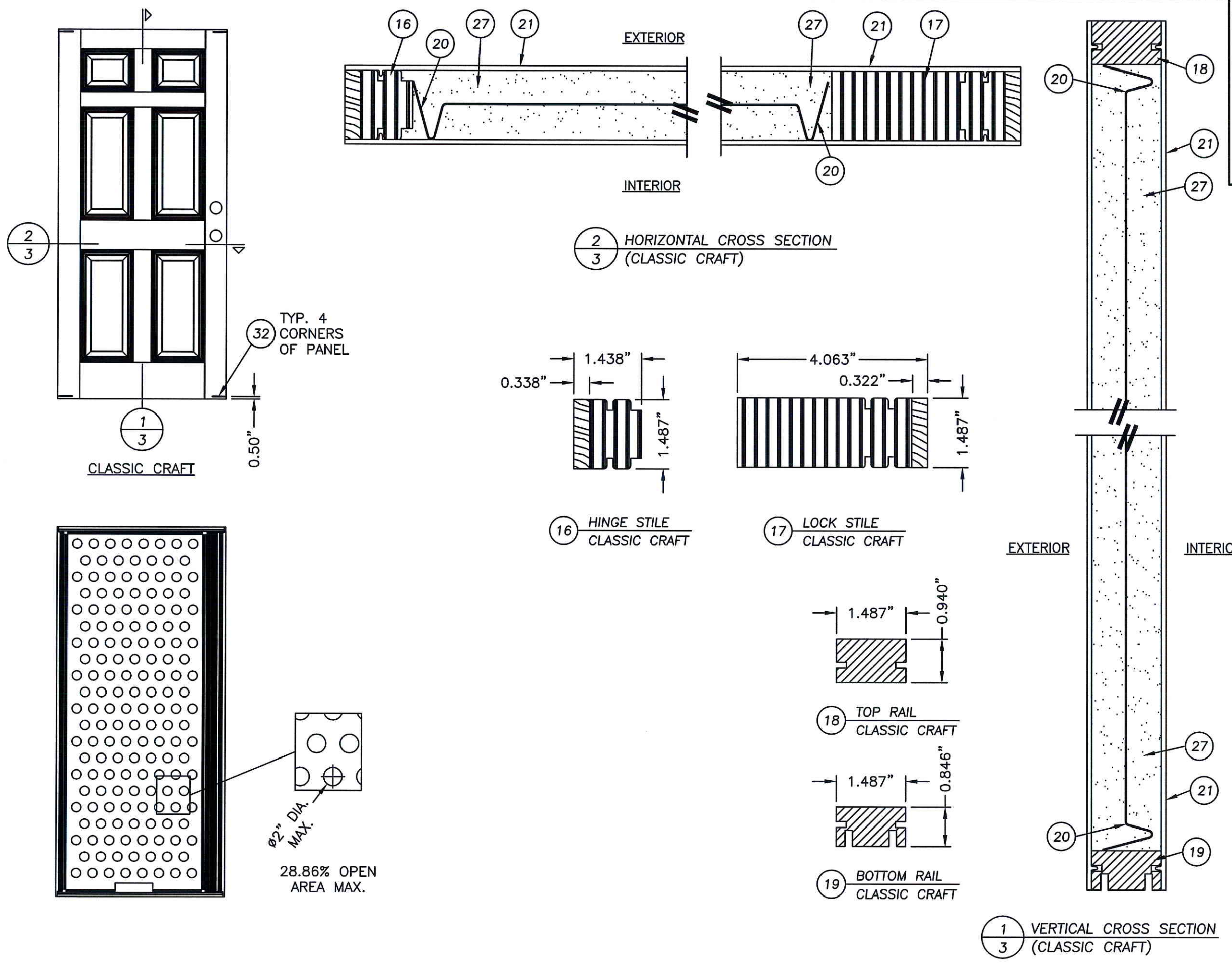

Documents Prepared By: Lyndon F. Schmidt, P.E.
 TEXAS P.E. #104123

RW BUILDING CONSULTANTS, INC.
 P.O. Box 230 Valrico FL 33595
 Phone No.: 813.659.9197

TEXAS BOARD OF PROFESSIONAL ENGINEERS
 CERTIFICATE OF REGISTRATION # F-11852

PRODUCT: SINGLE OPAQUE
 FIBERGLASS DOOR W/ SIDELITE
 "IMPACT" INSWING / OUTSWING

PART OR ASSEMBLY:
 DOOR PANEL DETAILS
 (CLASSIC CRAFT)

REVISIONS	
NO.	DATE

DATE: 7/17/12

SCALE: N.T.S.

DWG. BY: JK

CHK. BY: LFS

DRAWING NO.: TX-4186

SHEET 3 OF 12

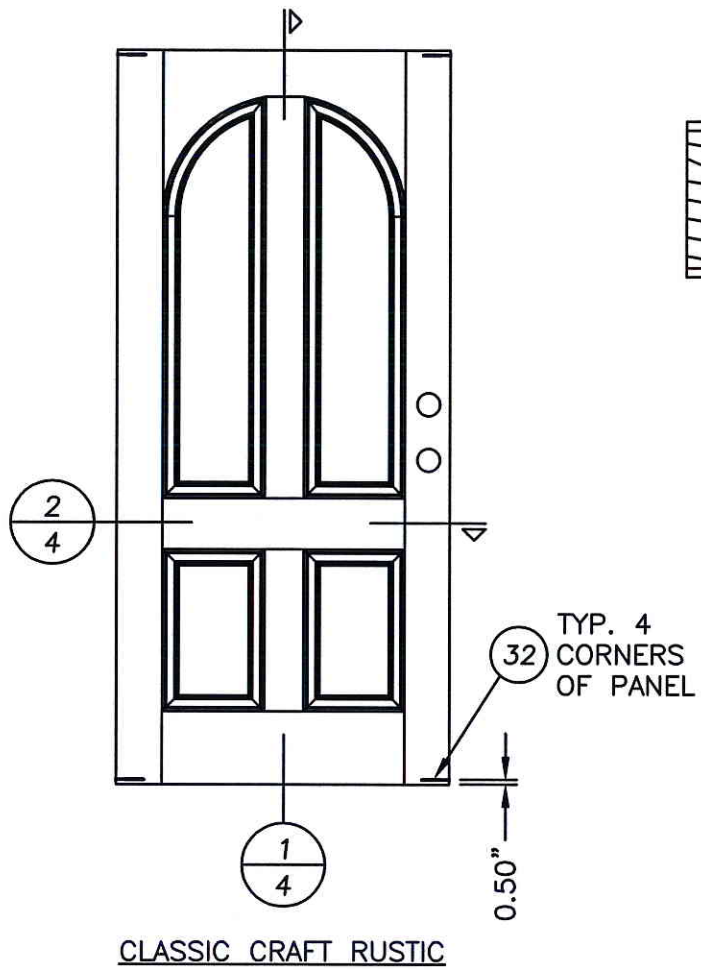

CLASSIC CRAFT RUSTIC

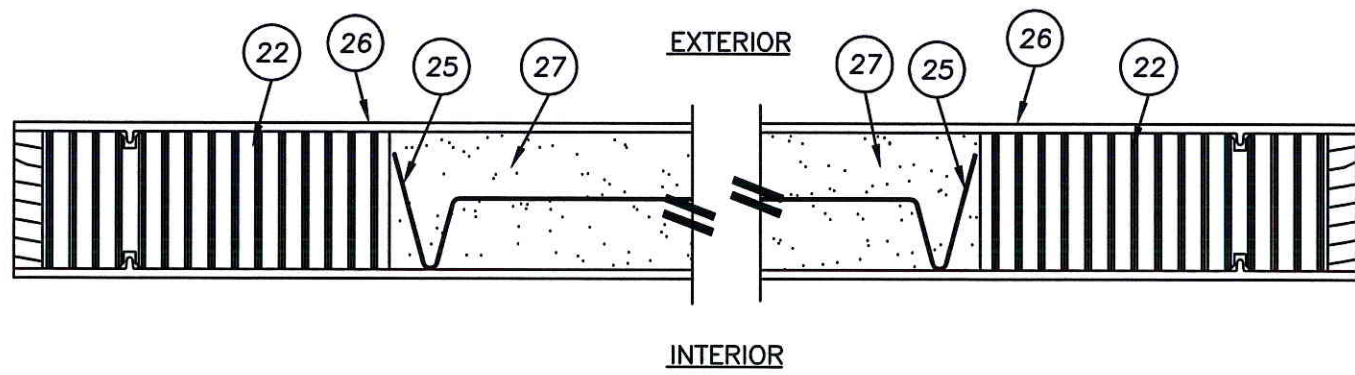

2/4 HORIZONTAL CROSS SECTION (CLASSIC CRAFT RUSTIC)

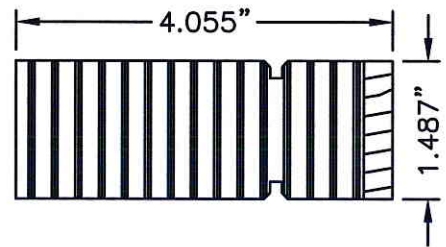

22 LOCK & HINGE STILE CLASSIC CRAFT RUSTIC

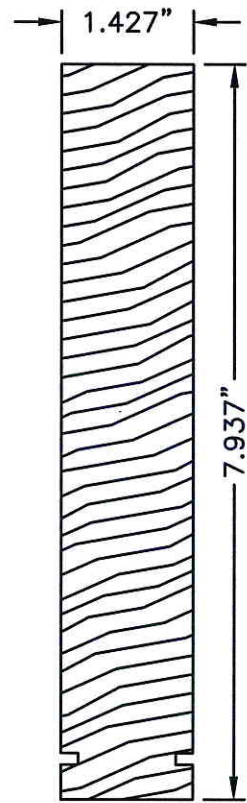

23 TOP RAIL CLASSIC CRAFT RUSTIC

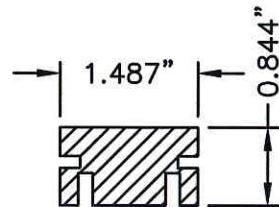

24 BOTTOM RAIL CLASSIC CRAFT RUSTIC

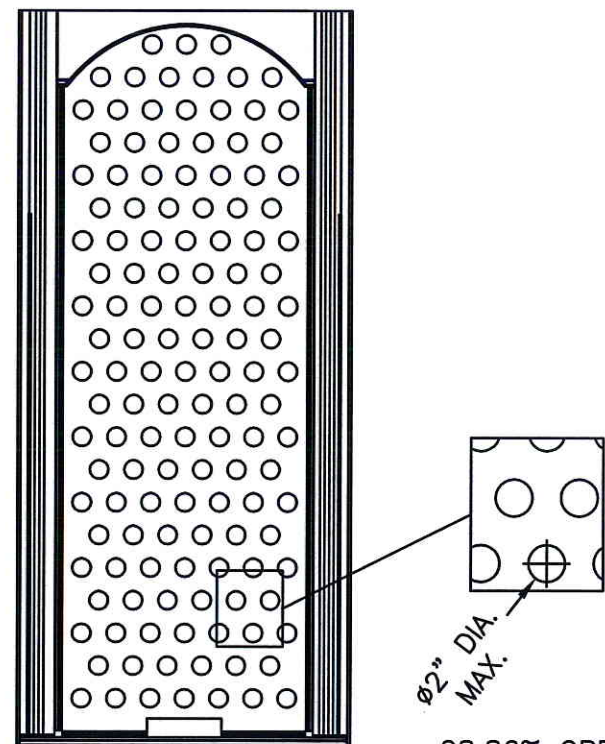

28.86% OPEN AREA MAX.

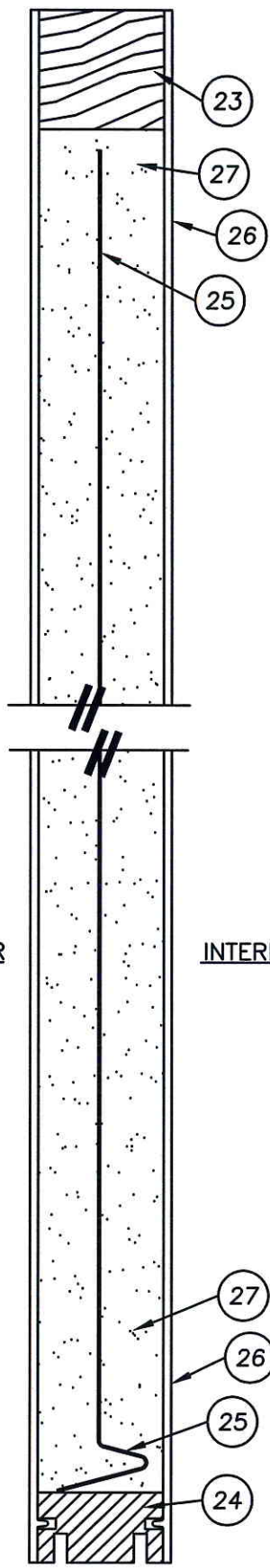

1/4 VERTICAL CROSS SECTION (CLASSIC CRAFT RUSTIC)



Documents Prepared By: Lyndon F. Schmidt, P.E.
TEXAS P.E. #104123

RW BUILDING CONSULTANTS, INC.
P.O. Box 230 Vairico FL. 33595
Phone No.: 813.659.9197

TEXAS BOARD OF PROFESSIONAL ENGINEERS
CERTIFICATE OF REGISTRATION # F-11852

PRODUCT: SINGLE OPAQUE FIBERGLASS DOOR W/SIDELITE "IMPACT" INSWING / OUTSWING
PART OR ASSEMBLY: DOOR PANEL DETAILS (CLASSIC CRAFT RUSTIC)

NO.	DATE	BY	REVISIONS

DATE: 07/17/12
SCALE: N.T.S.
DWG. BY: JK
CHK. BY: LFS
DRAWING NO.: TX-4186
SHEET 4 OF 12

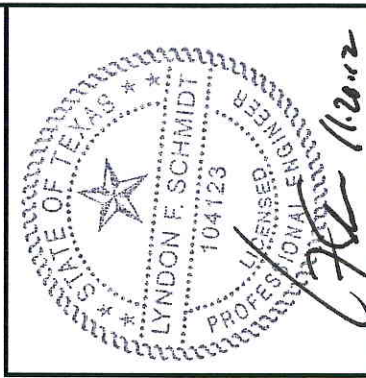
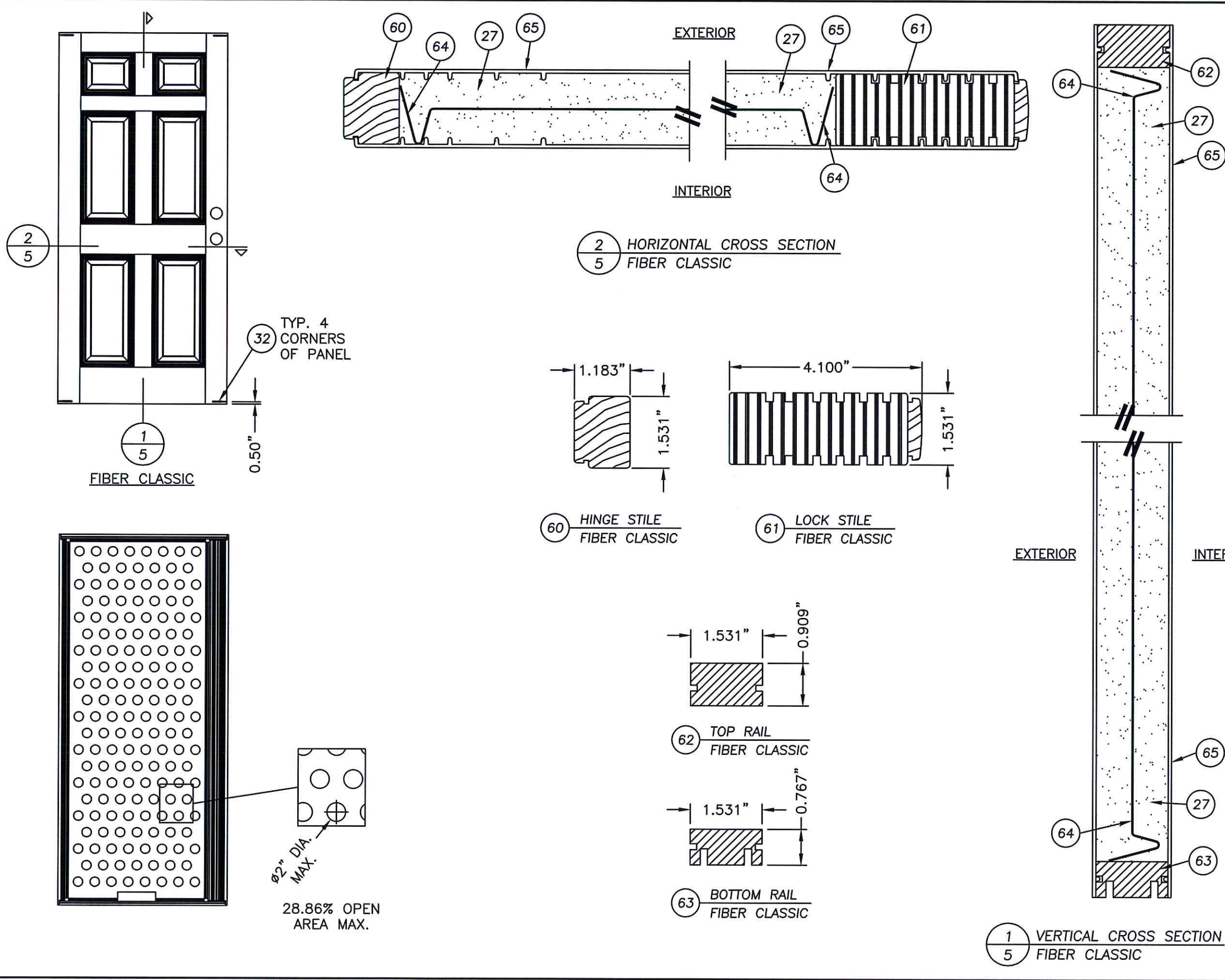

Documents Prepared By: Lyndon F. Schmidt, P.E.
 TEXAS P.E. #104123

RW BUILDING CONSULTANTS, INC.
 P.O. Box 230 Valrico FL 33595
 Phone No.: 813.659.9197

TEXAS BOARD OF PROFESSIONAL ENGINEERS
 CERTIFICATE OF REGISTRATION # F-11852

PRODUCT: SINGLE OPAQUE
 FIBERGLASS DOOR W/SIDELITE
 "IMPACT" INSWING / OUTSWING

PART OR ASSEMBLY:
 DOOR PANEL DETAILS
 (FIBER CLASSIC)

NO.	DATE	BY	REVISIONS

DATE: 07/17/12
 SCALE: N.T.S.
 DWG. BY: JK
 CHK. BY: LFS
 DRAWING NO.: TX-4186
 SHEET 5 of 12

R:\A - Projects\Project Folders\Proj 1101 - 1200\p1103\1.D. RWBC Drawings\TX-4184-89.dwg, FOX6

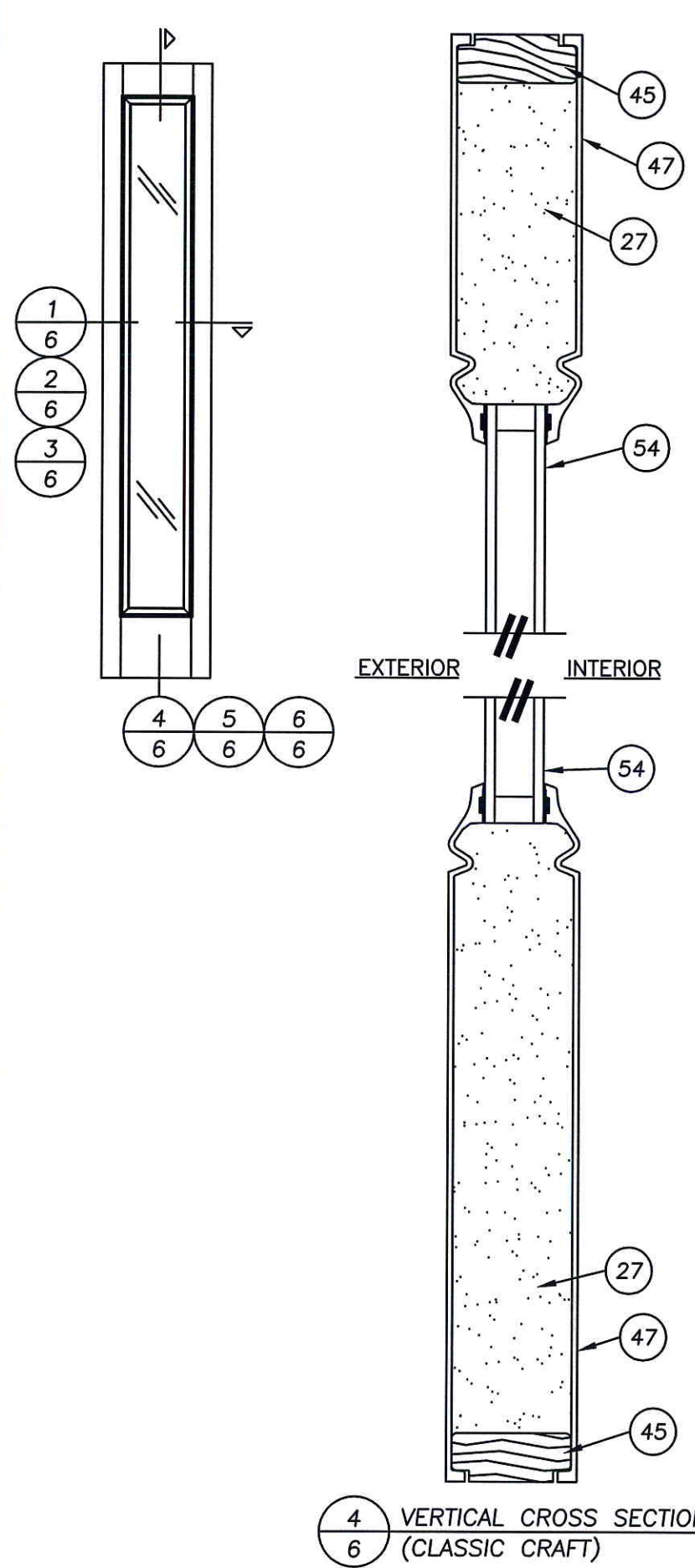

4 VERTICAL CROSS SECTION
6 (CLASSIC CRAFT)

5 VERTICAL CROSS SECTION
6 (FIBER CLASSIC)

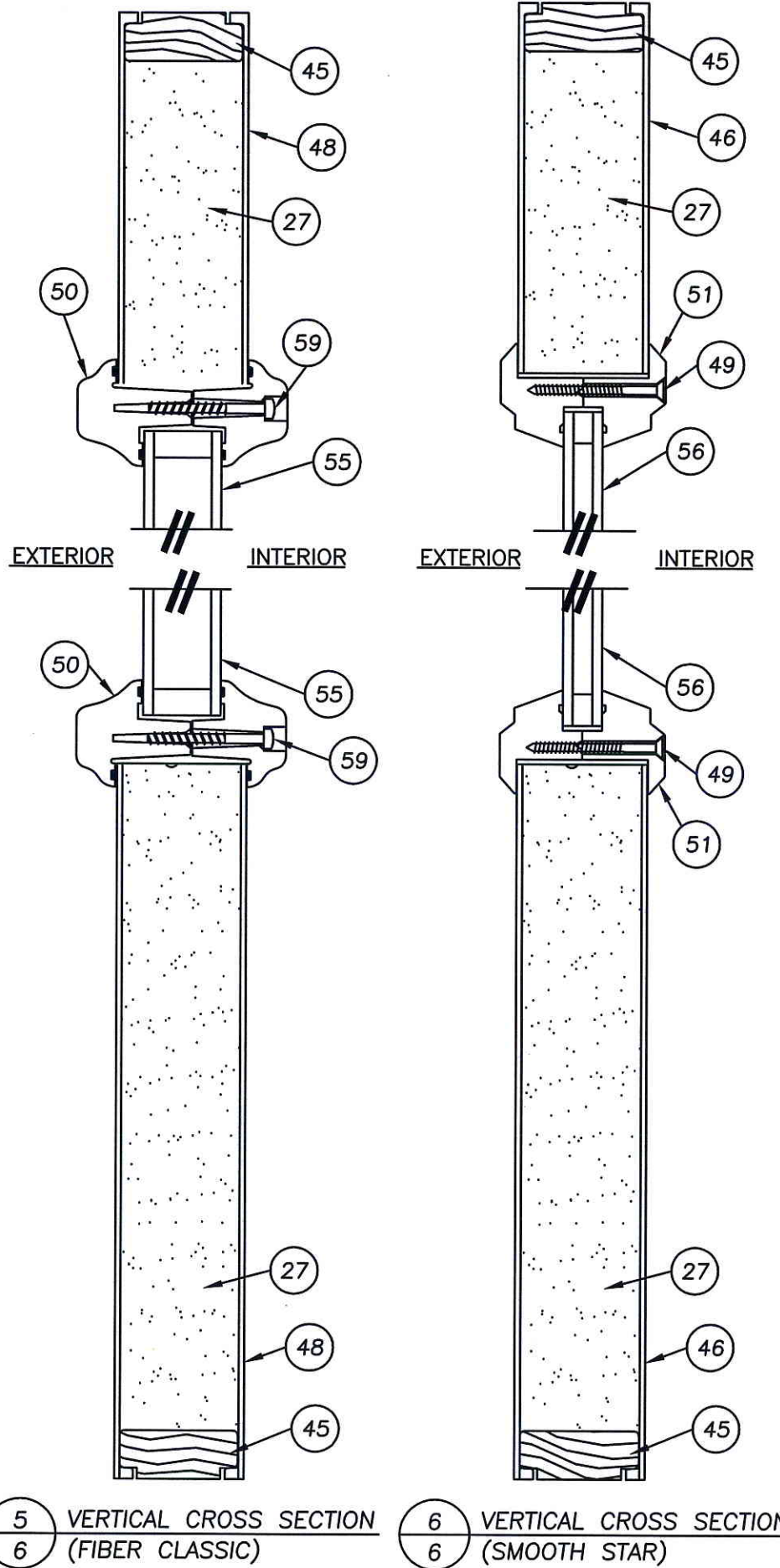

6 VERTICAL CROSS SECTION
6 (SMOOTH STAR)

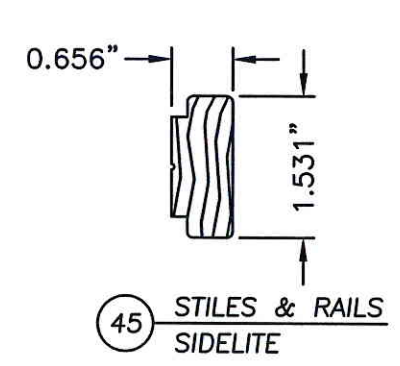

45 STILES & RAILS
SIDELITE

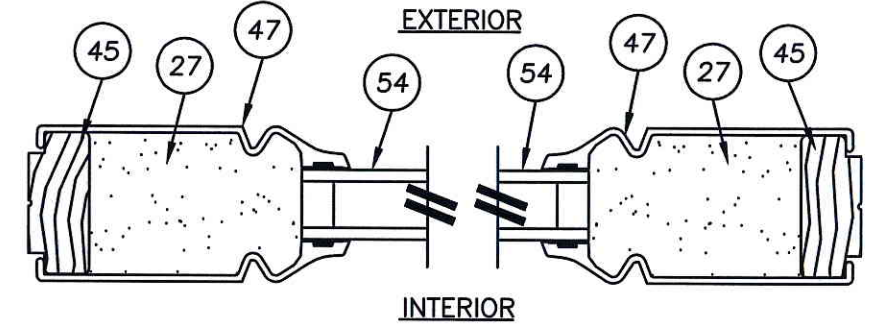

1 HORIZONTAL CROSS SECTION
6 (CLASSIC CRAFT)

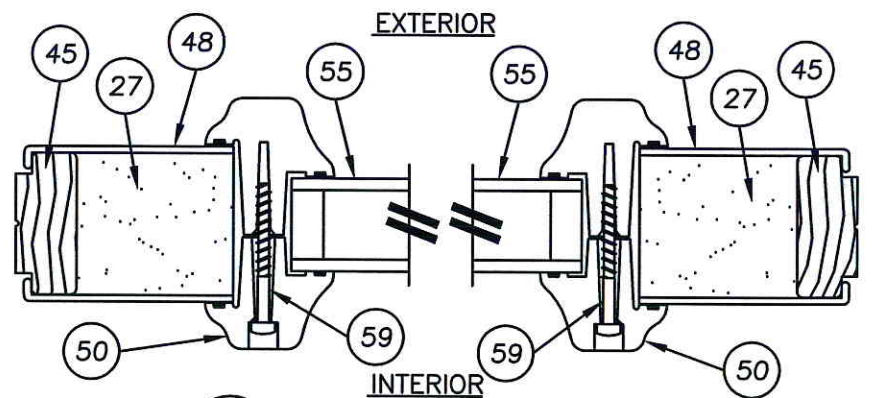

2 HORIZONTAL CROSS SECTION
6 (FIBER CLASSIC)

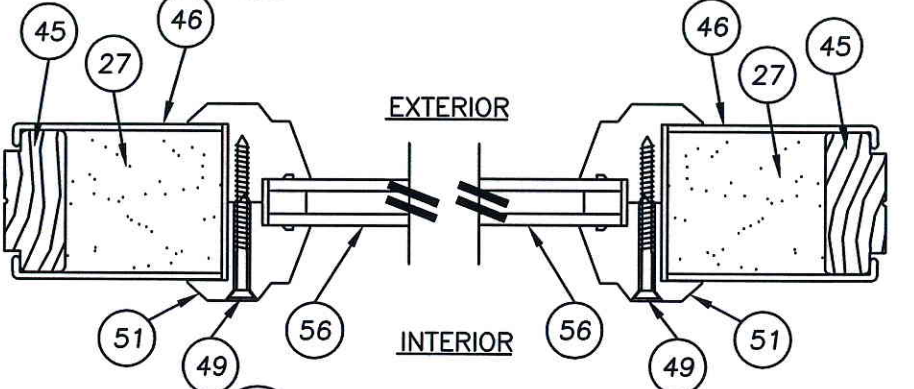

3 HORIZONTAL CROSS SECTION
6 (SMOOTH STAR)

Documents Prepared By: Lyndon F. Schmidt, P.E.
TEXAS P.E. #104123

RW BUILDING CONSULTANTS, INC.
P.O. Box 230 Valrico FL 33595
Phone No.: 813.659.9197

TEXAS BOARD OF PROFESSIONAL ENGINEERS
CERTIFICATE OF REGISTRATION # F-11852

PRODUCT: SINGLE OPAQUE
FIBERGLASS DOOR W/ SIDELITE
"IMPACT" INSWING / OUTSWING
PART OR ASSEMBLY: SIDELITE PANEL DETAILS

NO.	DATE	BY	REVISIONS

DATE: 07/17/12
SCALE: N.T.S.
DWG. BY: JK
CHK. BY: LFS
DRAWING NO.: TX-4186
SHEET 6 OF 12

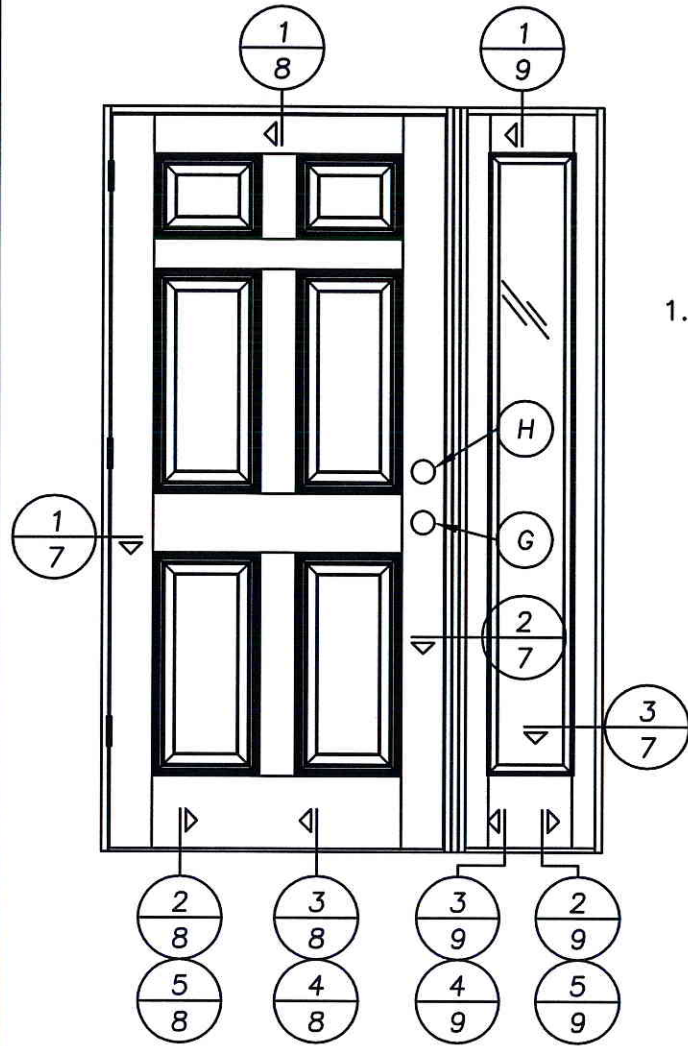

NOTE:
 1. SIDELITE ASSEMBLY SCREWS LOCATED 4" FROM ENDS AND 5 MORE EQUALLY SPACED (7 TOTAL).

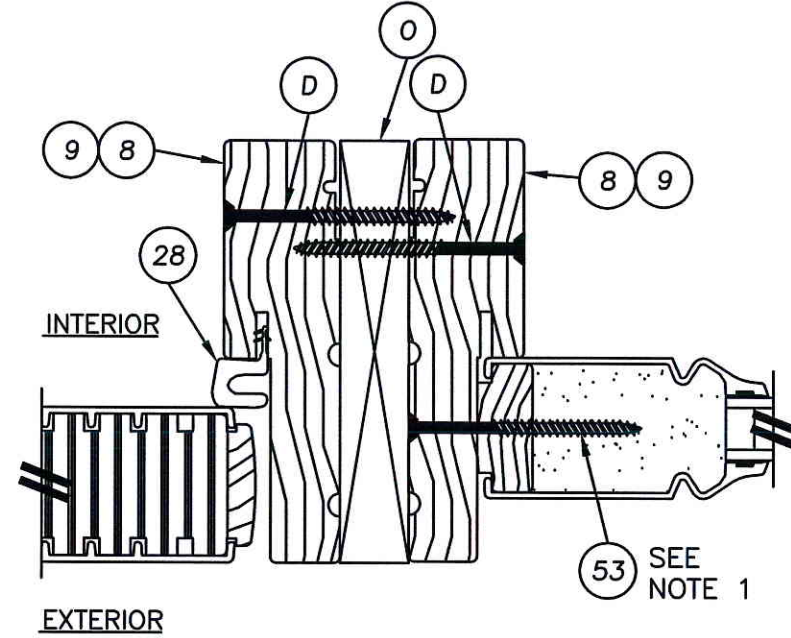

2 HORIZONTAL CROSS SECTION
7 OUTSWING SHOWN - INSWING ALSO APPROVED
 SMOOTH STAR PANEL SHOWN
 SEE DOOR PANEL DETAILS FOR
 OPTIONAL PANEL TYPES

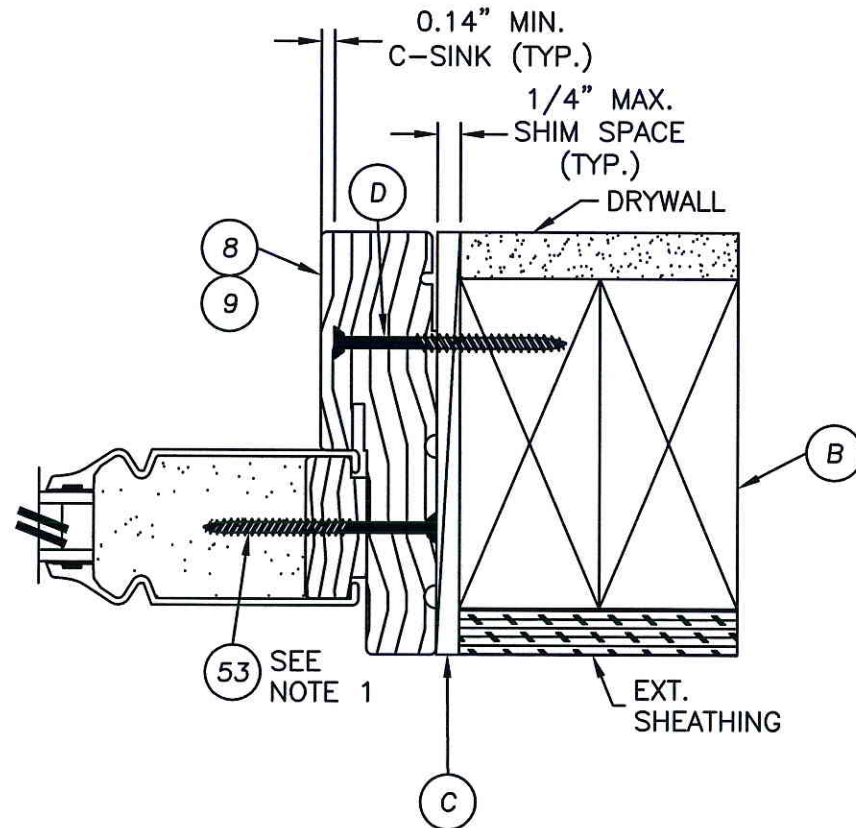

3 HORIZONTAL CROSS SECTION
7 OUTSWING SHOWN - INSWING ALSO APPROVED
 SMOOTH STAR PANEL SHOWN
 SEE DOOR PANEL DETAILS FOR
 OPTIONAL PANEL TYPES

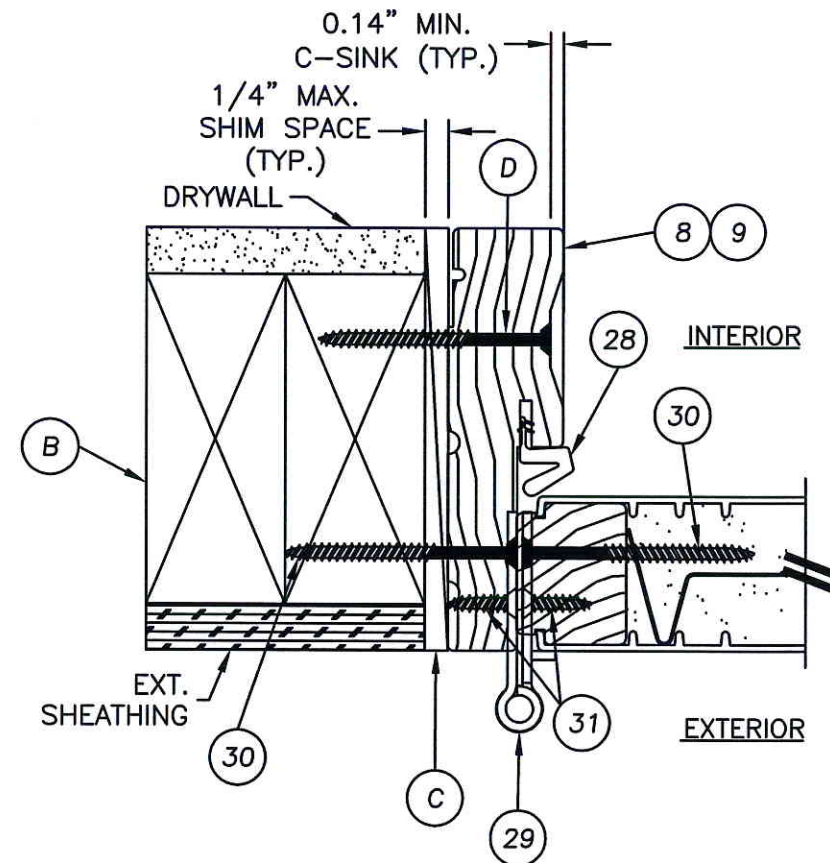

1 HORIZONTAL CROSS SECTION
7 OUTSWING SHOWN - INSWING ALSO APPROVED
 SMOOTH STAR PANEL SHOWN
 SEE DOOR PANEL DETAILS FOR
 OPTIONAL PANEL TYPES

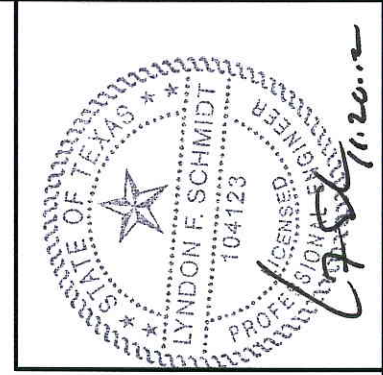

Documents Prepared By: Lyndon F. Schmidt, P.E.
 TEXAS P.E. #104123

RW BUILDING CONSULTANTS, INC.
 P.O. Box 230 Valrico FL 33595
 Phone No.: 813.659.9197
 TEXAS BOARD OF PROFESSIONAL ENGINEERS
 CERTIFICATE OF REGISTRATION # F-11852

PRODUCT: SINGLE OPAQUE
 FIBERGLASS DOOR W/ SIDELITE
 "IMPACT" INSWING / OUTSWING
 PART OR ASSEMBLY:
 HORIZONTAL CROSS SECTIONS
 & GLAZING DETAILS

NO.	DATE	BY	REVISIONS

DATE: 07/17/12

SCALE: N.T.S.

DWG. BY: JK

CHK. BY: LFS

DRAWING NO.: TX-4186

SHEET 7 of 12

R:\A - Projects\Project Folders\Proj 1101 - 1200\p1103\1.D. RWBC Drawings\TX-4184-89.dwg, FOX8

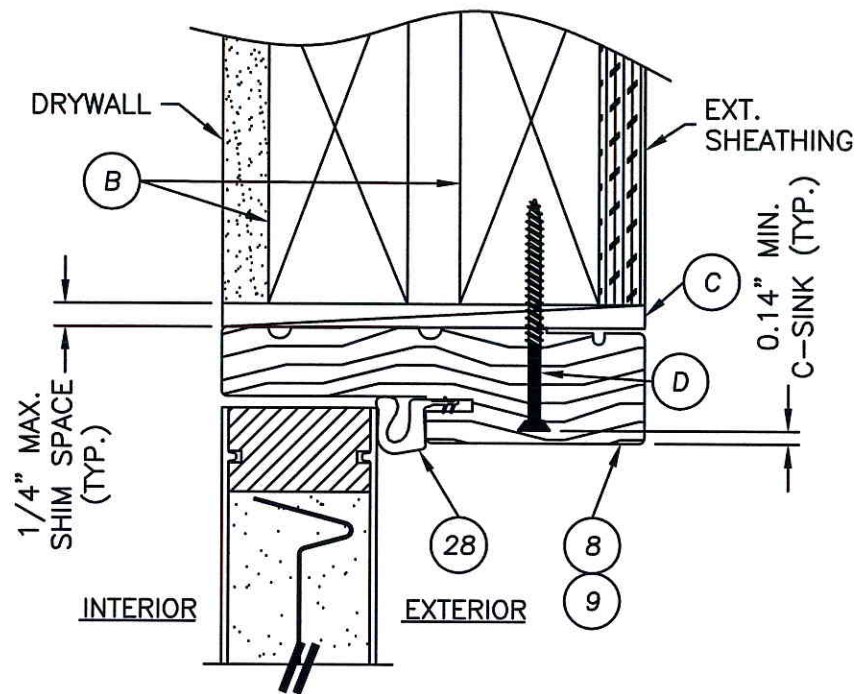

1 VERTICAL CROSS SECTION
 8 INSWING SHOWN - OUTSWING ALSO APPROVED
 SMOOTH STAR PANEL SHOWN
 SEE DOOR PANEL DETAILS FOR
 OPTIONAL PANEL TYPES

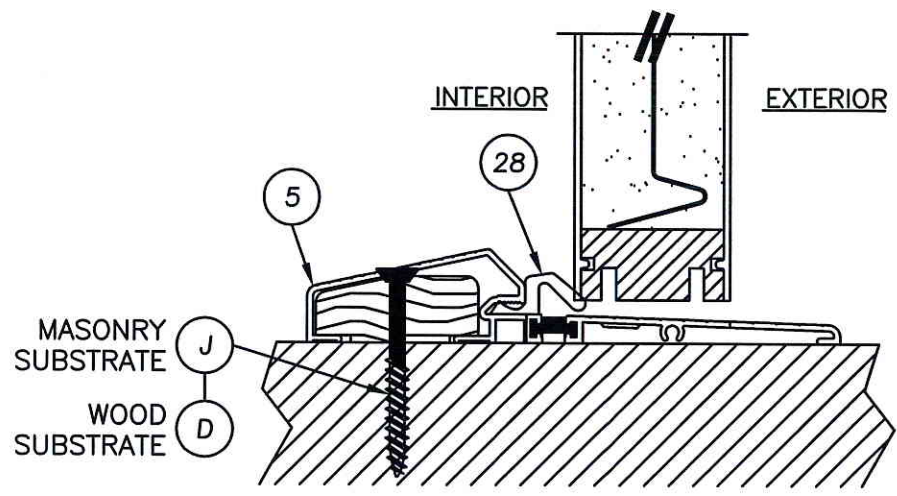

2 VERTICAL CROSS SECTION
 8 @ THRESHOLD
 SMOOTH STAR PANEL SHOWN
 SEE DOOR PANEL DETAILS FOR
 OPTIONAL PANEL TYPES

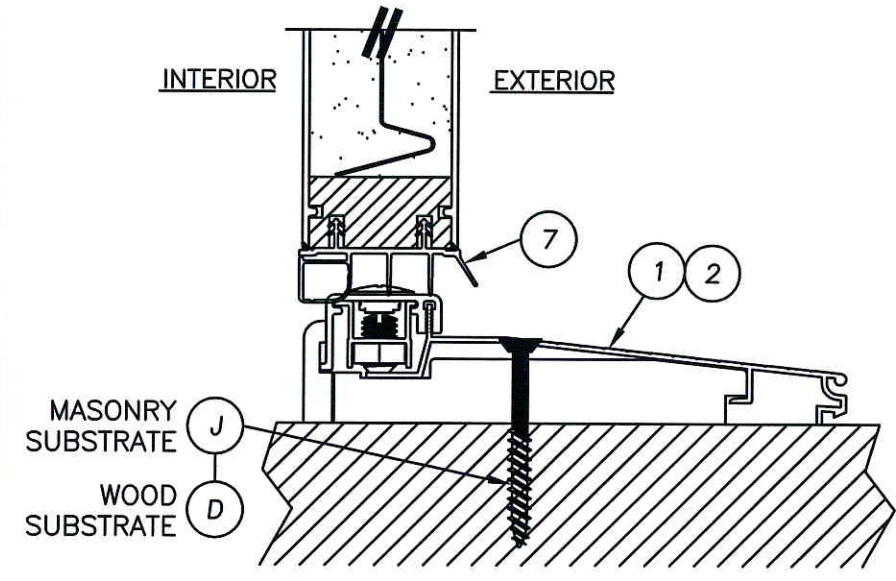

3 VERTICAL CROSS SECTION
 8 @ THRESHOLD
 SMOOTH STAR PANEL SHOWN
 SEE DOOR PANEL DETAILS FOR
 OPTIONAL PANEL TYPES

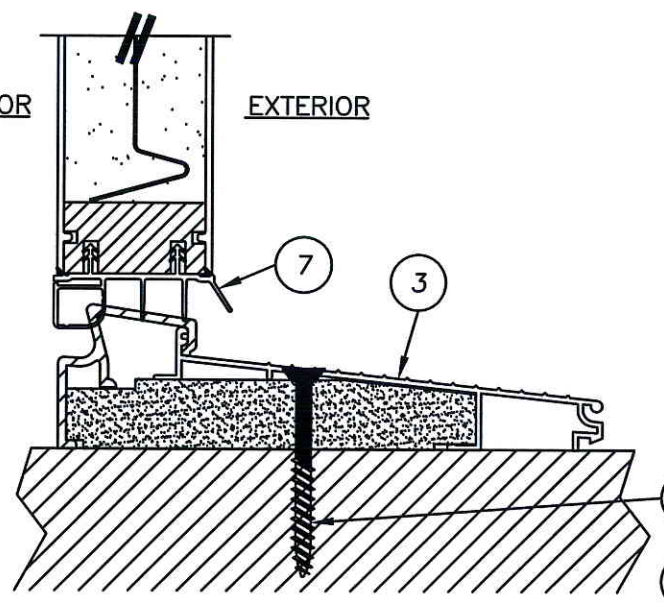

4 VERTICAL CROSS SECTION
 8 @ THRESHOLD
 SMOOTH STAR PANEL SHOWN
 SEE DOOR PANEL DETAILS FOR
 OPTIONAL PANEL TYPES

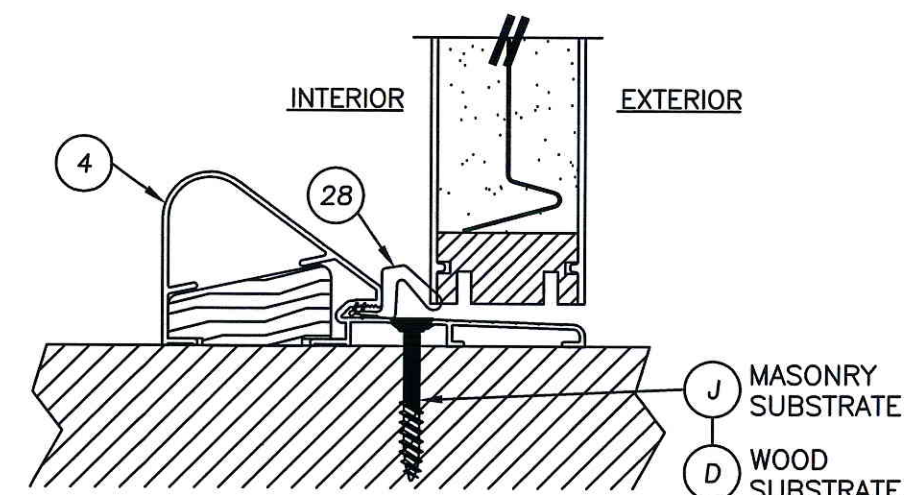

5 VERTICAL CROSS SECTION
 8 @ THRESHOLD
 SMOOTH STAR PANEL SHOWN
 SEE DOOR PANEL DETAILS FOR
 OPTIONAL PANEL TYPES

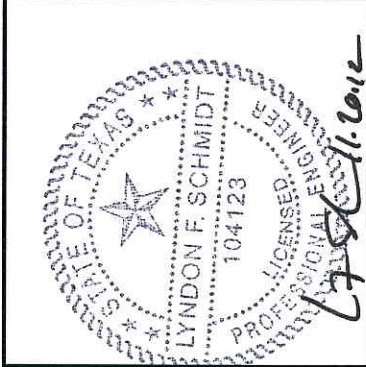

Documents Prepared By: Lyndon F. Schmidt, P.E.
 TEXAS P.E. #104123

RW BUILDING CONSULTANTS, INC.
 P.O. Box 230 Vairico FL 33595
 Phone No.: 813.659.9197

TEXAS BOARD OF PROFESSIONAL ENGINEERS
 CERTIFICATE OF REGISTRATION # F-11852

PRODUCT: SINGLE OPAQUE
 FIBERGLASS DOOR W/ SIDELITE
 "IMPACT" INSWING / OUTSWING
 PART OR ASSEMBLY: VERTICAL CROSS SECTIONS

NO.	DATE	BY	REVISIONS

DATE: 07/17/12
 SCALE: N.T.S.
 DWG. BY: JK
 CHK. BY: LFS
 DRAWING NO.: TX-4186
 SHEET 8 OF 12

© 2012 R.W. BUILDING CONSULTANTS INC.

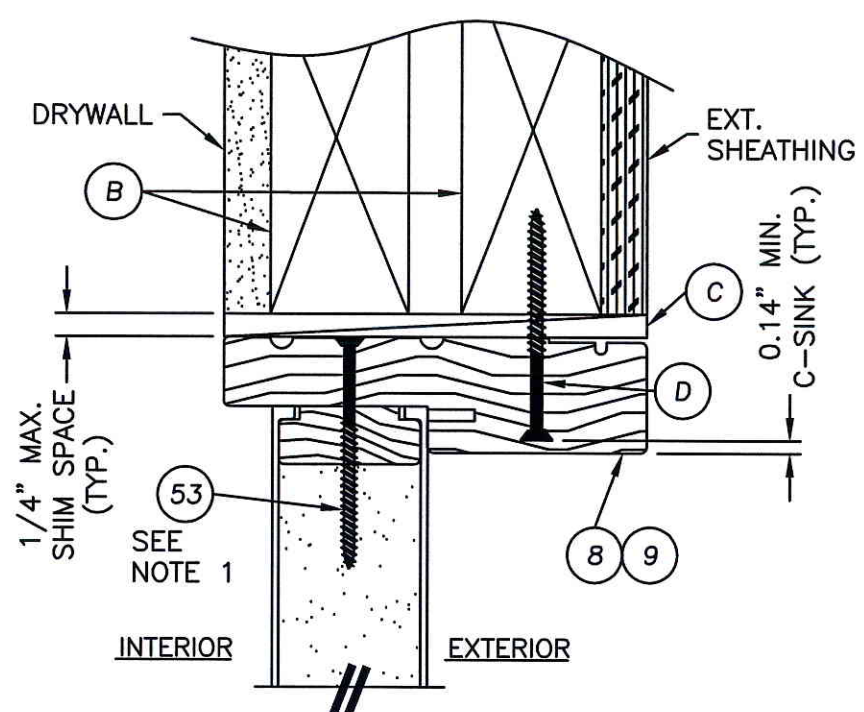

1 VERTICAL CROSS SECTION
9 INSWING SHOWN - OUTSWING ALSO APPROVED

NOTE:
1. SIDELITE ASSEMBLY SCREWS LOCATED 4.25\"/>

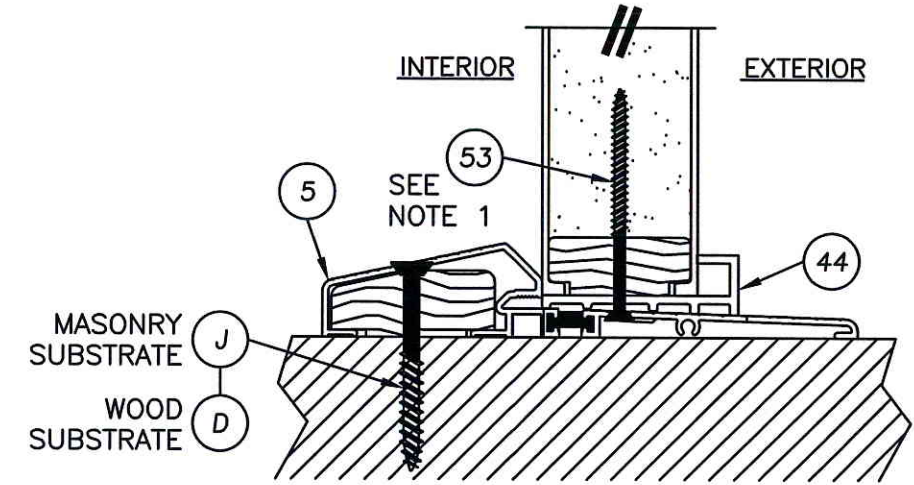

2 VERTICAL CROSS SECTION
9

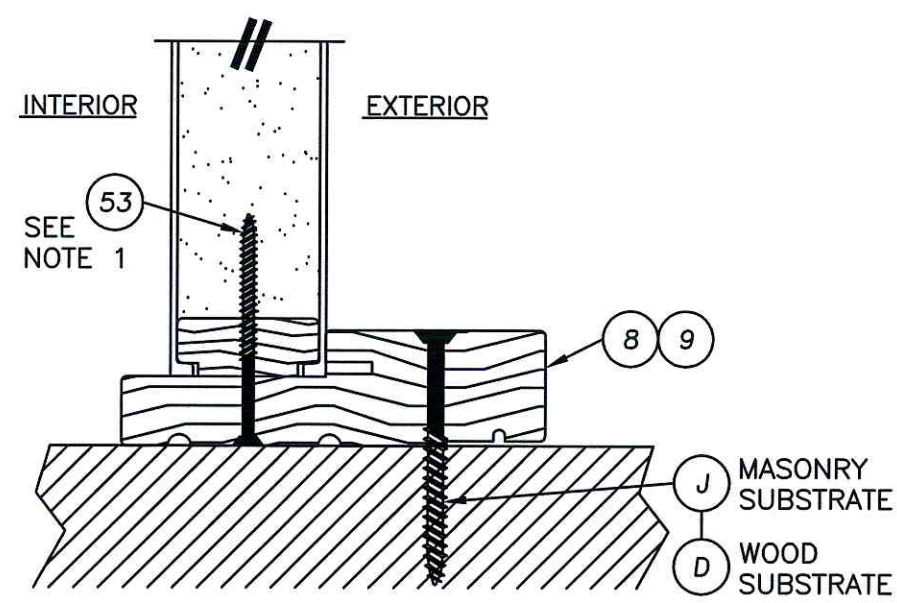

3 VERTICAL CROSS SECTION
9

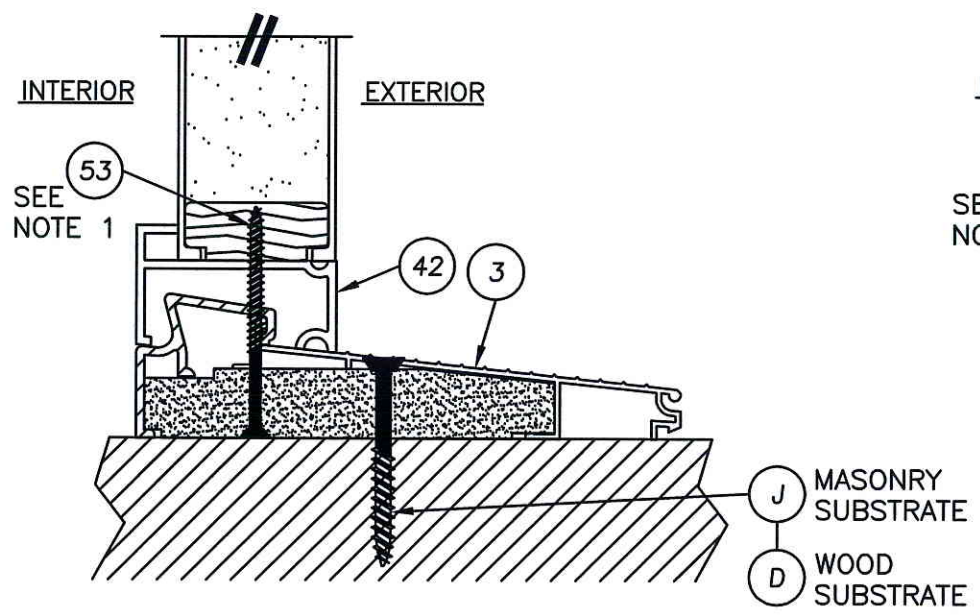

4 VERTICAL CROSS SECTION
9

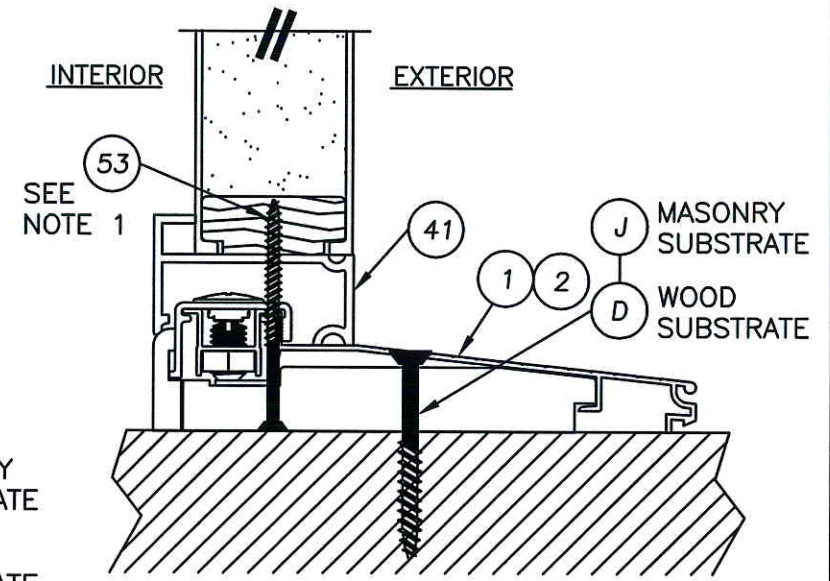

5 VERTICAL CROSS SECTION
9



Documents Prepared By: Lyndon F. Schmidt, P.E.
TEXAS P.E. #104123

RW BUILDING CONSULTANTS, INC.
P.O. Box 230 Valrico FL 33595
Phone No.: 813.659.9197

TEXAS BOARD OF PROFESSIONAL ENGINEERS
CERTIFICATE OF REGISTRATION # F-11852

PRODUCT: SINGLE OPAQUE FIBERGLASS DOOR W/ SIDELITE "IMPACT" INSWING / OUTSWING
PART OR ASSEMBLY: VERTICAL CROSS SECTIONS

NO.	DATE	BY	REVISIONS

DATE: 07/17/12
SCALE: N.T.S.
DWG. BY: JK
CHK. BY: LFS
DRAWING NO.: TX-4186
SHEET 9 OF 12

THE ENGINEER OR ARCHITECT OF RECORD TO DETERMINE FRAMING REQUIREMENTS BASED ON WIND LOADS AND THE CLADDING BEING USED.

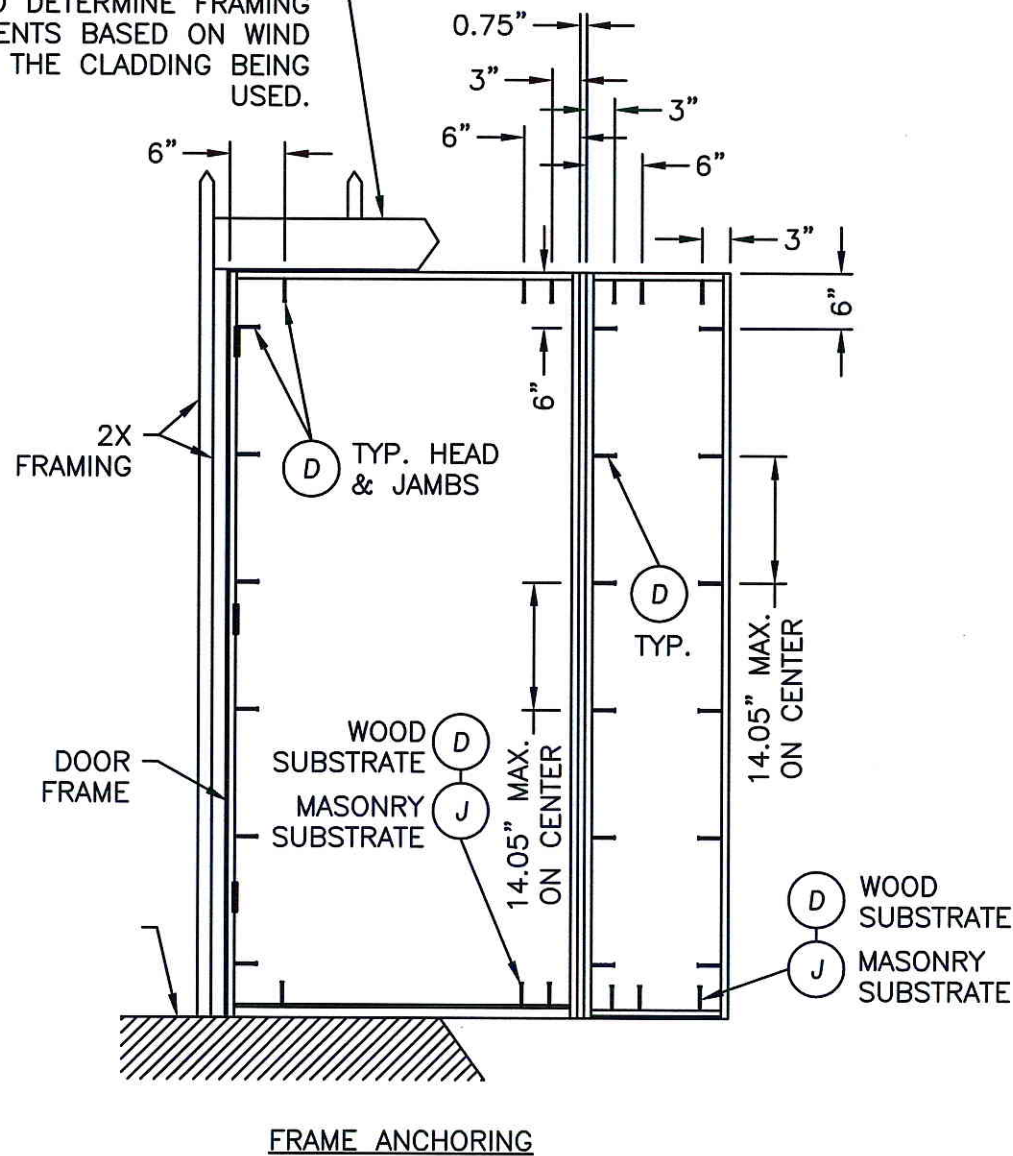

FRAME ANCHORING

CONCRETE ANCHOR NOTES:

1. Concrete anchor locations at the corners may be adjusted to maintain the min. edge distance to mortar joints.
2. Concrete anchor locations noted as "MAX. ON CENTER" must be adjusted to maintain the min. edge distance to mortar joints, additional concrete anchors may be required to ensure the "MAX. ON CENTER" dimension are not exceeded.
3. Concrete anchor table:

ANCHOR TYPE	ANCHOR SIZE	MIN. EMBEDMENT	MIN. CLEARANCE TO MASONRY EDGE	MIN. CLEARANCE TO ADJACENT ANCHOR
ITW TAPCON®	1/4"	1-3/4"	2-1/2"	3"
ELCO ULTRACON®	1/4"	1-3/4"	1"	3"

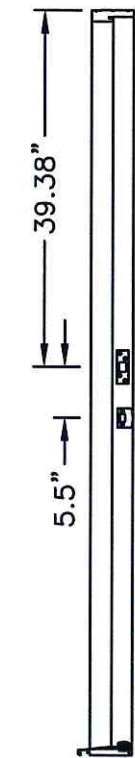

STRIKE PLATE LOCATIONS

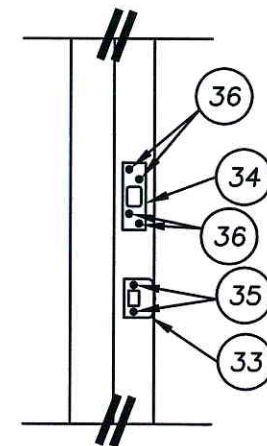

STRIKE PLATE DETAIL

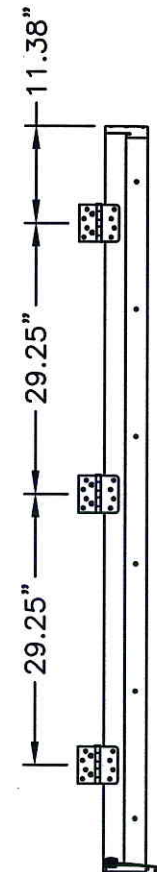

HINGE LOCATIONS

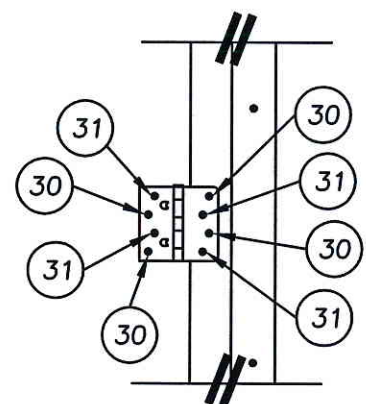

HINGE DETAIL

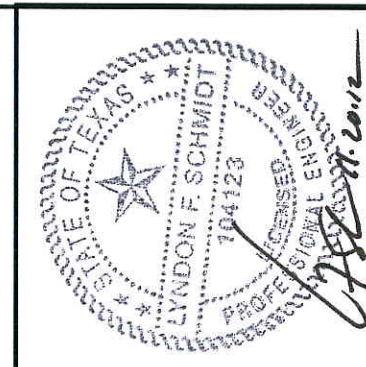

Documents Prepared By: Lyndon F. Schmidt, P.E.
TEXAS P.E. #104123

RW BUILDING CONSULTANTS, INC.
P.O. Box 230 Vairico FL 33595
Phone No.: 813.659.9197

TEXAS BOARD OF PROFESSIONAL ENGINEERS
CERTIFICATE OF REGISTRATION # F-11852

PRODUCT: SINGLE OPAQUE FIBERGLASS DOOR W/SIDELITE "IMPACT" INSWING / OUTSWING

PART OR ASSEMBLY: FRAME ANCHORING

NO.	DATE	BY	REVISIONS

DATE: 07/17/12
SCALE: N.T.S.
DWG. BY: JK
CHK. BY: LFS
DRAWING NO.: TX-4186
SHEET 10 OF 12

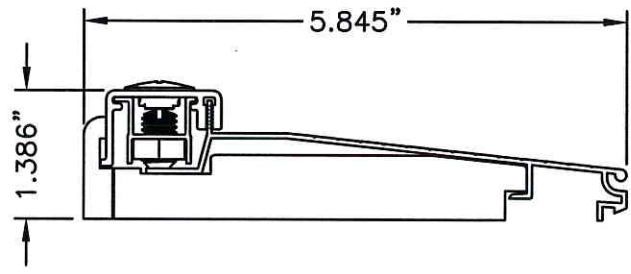

2 THRESHOLD
IN SWING ADJUSTABLE

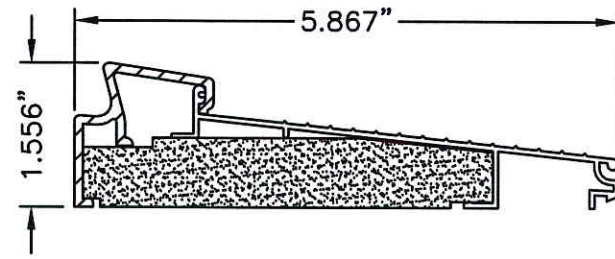

3 THRESHOLD
IN SWING SELF-ADJUST

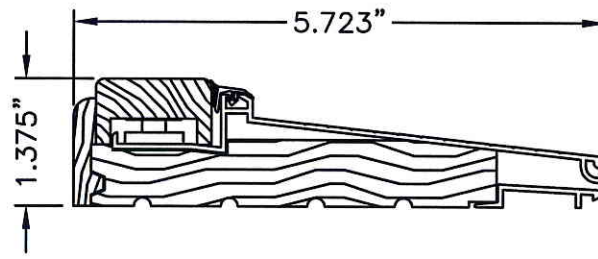

1 THRESHOLD
IN SWING ADJUSTABLE

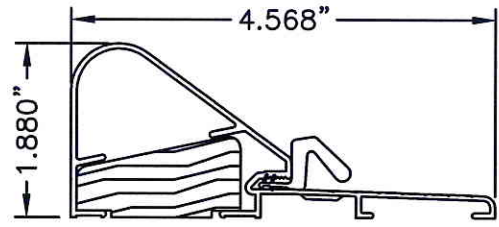

4 THRESHOLD
OUT SWING COASTAL

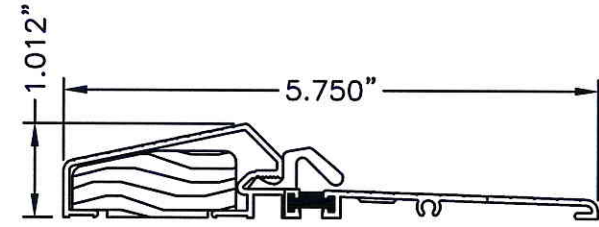

5 THRESHOLD
OUT SWING STANDARD

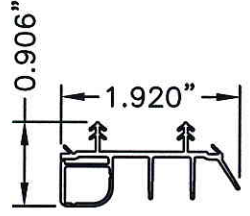

7 SWEEP

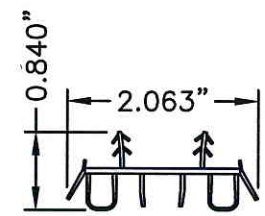

52 SWEEP

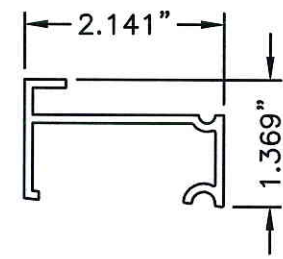

42 IN SWING SIDELITE
SPACER

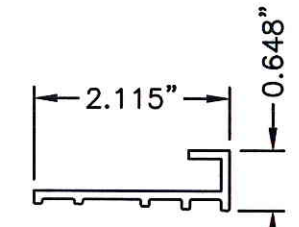

44 OUT SWING SIDELITE
SPACER

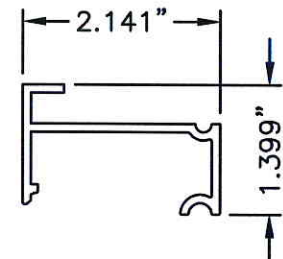

41 IN SWING SIDELITE
SPACER

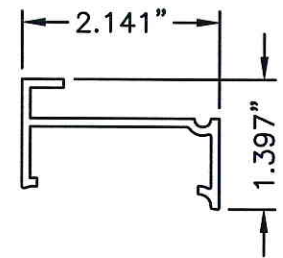

40 IN SWING SIDELITE
SPACER

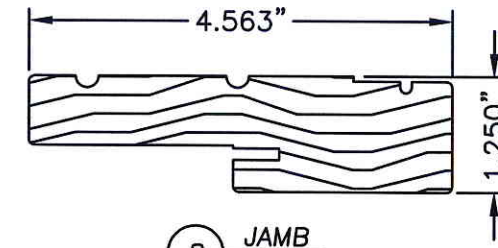

9 8 JAMB

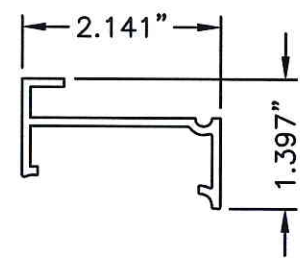

43 IN SWING SIDELITE
SPACER

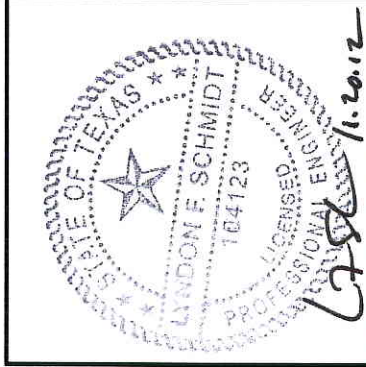

Documents Prepared By: Lyndon F. Schmidt, P.E.
TEXAS P.E. #104123

RW BUILDING CONSULTANTS, INC.
P.O. Box 230 Vairico FL 33595
Phone No.: 813.659.9197

TEXAS BOARD OF PROFESSIONAL ENGINEERS
CERTIFICATE OF REGISTRATION # F-11852

PRODUCT: SINGLE OPAQUE
FIBERGLASS DOOR W/ SIDELITE
"IMPACT" IN SWING / OUT SWING
PART OR ASSEMBLY: COMPONENTS

NO.	DATE	BY	REVISIONS

DATE: 07/17/12
SCALE: N.T.S.
DWG. BY: JK
CHK. BY: LFS
DRAWING NO.: TX-4186
SHEET 11 of 12

R:\A - Projects\Project Folders\Proj 1101 - 1200\pf1103\p. RWBC Drawings\TX-4184-89.dwg, FOX12

BILL OF MATERIALS

ITEM	DESCRIPTION	MATERIAL
B	2X FRAMING (G >= 0.42)	WOOD
C	1/4" MAX. SHIM SPACE	WOOD
D	#10 X 2-1/2" PFH WOOD SCREW	STEEL
G	KWIKSET 200 SERIES PASSAGE LOCK	STEEL
H	KWIKSET 600 SERIES DEADBOLT	STEEL
J	1/4" ELCO OR ITW CONCRETE SCREW (1-3/4" MIN. EMB.)	STEEL
O	1X MULLION (G >= 0.42)	WOOD
1	INSWING ADJUSTABLE THRESHOLD (IS300AJ)	ALUM./WOOD
2	INSWING THRESHOLD (IS300HP5)	-
3	INSWING SELF ADJUST THERMAL BREAK THRESHOLD (ISP30M)	ALUM./COMP.
4	OUTSWING COASTAL THRESHOLD	ALUM./WOOD
7	DOOR BOTTOM SWEEP	VINYL
8	JAMB (PINE)	WOOD
9	JAMB (OAK)	WOOD
10	HINGE STILE (SMOOTH STAR)	WOOD
11	LOCK STILE (SMOOTH STAR)	LVL/WOOD
12	TOP RAIL (SMOOTH STAR)	PVC
13	BOTTOM RAIL (SMOOTH STAR)	PVC
14	PANEL REINFORCEMENT 0.023" THK. (SMOOTH STAR)	STEEL
15	DOOR SKIN 0.070" THK. (SMOOTH STAR) Fy = 6,000 PSI MIN.	FIBERGLASS
16	HINGE STILE (CLASSIC CRAFT)	WOOD/LVL
17	LOCK STILE (CLASSIC CRAFT)	WOOD/LVL
18	TOP RAIL (CLASSIC CRAFT)	PVC
19	BOTTOM RAIL (CLASSIC CRAFT)	PVC
20	PANEL REINFORCEMENT 0.023" THK. (CLASSIC CRAFT)	STEEL
21	DOOR SKIN 0.090" THK. (CLASSIC CRAFT) Fy = 6,000 PSI MIN.	FIBERGLASS
22	LOCK & HINGE STILE (CLASSIC CRAFT RUSTIC)	WOOD/LVL
23	TOP RAIL (CLASSIC CRAFT RUSTIC)	WOOD
24	BOTTOM RAIL (CLASSIC CRAFT RUSTIC)	PVC
25	PANEL REINFORCEMENT 0.023" THK. (CLASSIC CRAFT RUSTIC)	STEEL
26	DOOR SKIN 0.090" THK. (CC RUSTIC) Fy = 6,000 PSI MIN.	FIBERGLASS
27	FOAM CORE	POLYURETHANE
28	WEATHERSTRIP	FOAM
29	HINGE	STEEL
30	#10 X 2-1/2" PFH SCREW	STEEL
31	#10 X 3/4" PFH SCREW	STEEL
32	#9 X 3" PFH WOOD SCREW	STEEL
33	LATCH STRIKE PLATE	STEEL
34	SECURITY STRIKE PLATE (SINGLE DOOR ONLY)	STEEL
35	#8 X 3" PFH SCREW	STEEL
36	#8 X 3" PFH SCREW	STEEL

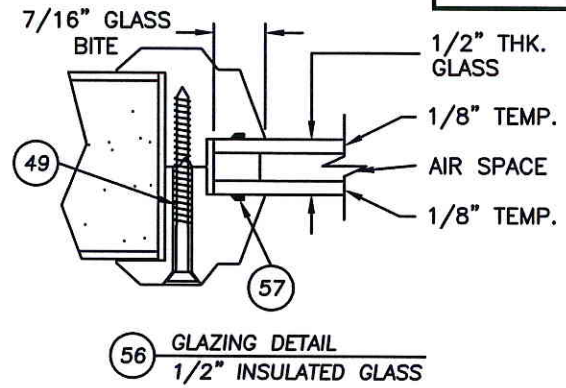
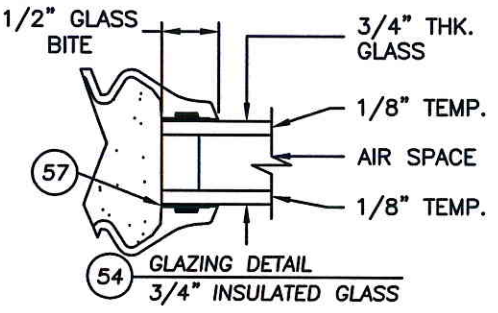
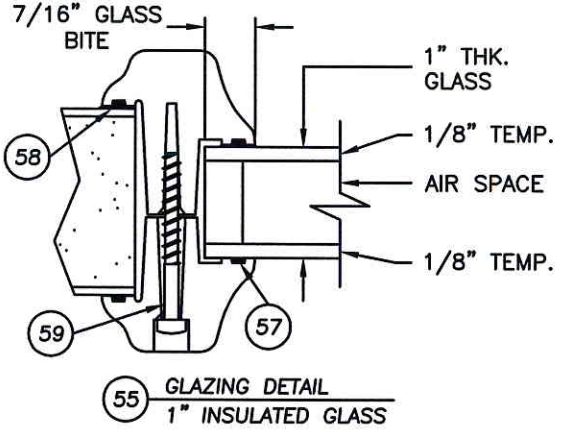

BILL OF MATERIALS

ITEM	DESCRIPTION	MATERIAL
40	INSWING SIDELITE SPACER FOR ADJUSTABLE THRESHOLD (DB14AJA)	PVC
41	INSWING SIDELITE SPACER FOR HP THRESHOLD (DB14HPA)	PVC
42	INSWING SIDELITE SPACER FOR SELF ADJUST THRESHOLD (DB14)	PVC
43	INSWING SIDELITE SPACER	PVC
44	OUTSWING SIDELITE SPACER	PVC
45	SIDELITE STILES & RAILS	WOOD
46	SIDELITE SKIN 0.070" THK. (SMOOTH STAR)	FIBERGLASS
47	SIDELITE SKIN 0.090" THK. (CLASSIC CRAFT)	FIBERGLASS
48	SIDELITE SKIN 0.070" THK. (FIBER CLASSIC)	FIBERGLASS
49	#6 X 1-3/4" PFH SCREW (LITE FRAME)	STEEL
50	LITE FRAME FIBER CLASSIC	PVC
51	LITE FRAME SMOOTH STAR	PVC
52	DOOR BOTTOM SWEEP	VINYL
53	#9 X 2-1/2" PFH WOOD SCREW	STEEL
54	3/4" INSULATED GLASS 1/8" TEMPERED - AIR - 1/8" TEMPERED	GLASS
55	1" INSULATED GLASS 1/8" TEMPERED - AIR - 1/8" TEMPERED	GLASS
56	1/2" INSULATED GLASS 1/8" TEMPERED - AIR - 1/8" TEMPERED	GLASS
57	GLAZING COMPOUND	SILICONE
58	SEALANT	SILICONE
59	#9 X 1" PPH SCREW (LITE FRAME)	STEEL
60	HINGE STILE (FIBER CLASSIC)	WOOD
61	LOCK STILE (FIBER CLASSIC)	LVL/WOOD
62	TOP RAIL (FIBER CLASSIC)	PVC
63	BOTTOM RAIL (FIBER CLASSIC)	PVC
64	PANEL REINFORCEMENT 0.023" THK. (FIBER CLASSIC)	STEEL
65	DOOR SKIN 0.072" THK. (FIBER CLASSIC) Fy = 6,000 PSI MIN.	FIBERGLASS

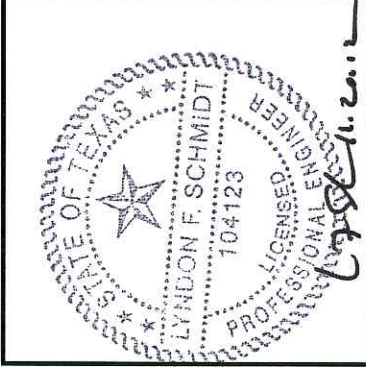

Documents Prepared By: Lyndon F. Schmidt, P.E.
TEXAS P.E. #104123

RW BUILDING CONSULTANTS, INC.
P.O. Box 230 Valrico FL 33595
Phone No.: 813.659.9197

TEXAS BOARD OF PROFESSIONAL ENGINEERS
CERTIFICATE OF REGISTRATION # F-11852

PRODUCT: SINGLE OPAQUE
FIBERGLASS DOOR W/ SIDELITE
"IMPACT" INSWING / OUTSWING
PART OR ASSEMBLY:
BILL OF MATERIALS
& GLAZING DETAILS

NO.	DATE	BY	REVISIONS

DATE: 07/17/12
SCALE: N.T.S.
DWG. BY: JK
CHK. BY: LFS
DRAWING NO.: TX-4186
SHEET 12 OF 12